

SKID STEER LOW PROFILE BUCKET - EA-SKSB-60-LPX

APPROX WEIGHT: 528.02 lbs.
DOES NOT INCLUDE WEIGHT OF POWER OR PACKAGING!!!

*** ANY ADDITIONS, DELETIONS, OR OMISSIONS MUST BE CORRECTED ON THIS DRAWING AS THIS DRAWING WILL BE CONSIDERED ALL INCLUSIVE ***
ALL GRAPHICS PROVIDED ARE FOR REFERENCE ONLY. IF CERTAIN DIMENSIONS ARE CRITICAL PLEASE VERIFY THOSE DIMENSIONS WITH YOUR SALESPERSON

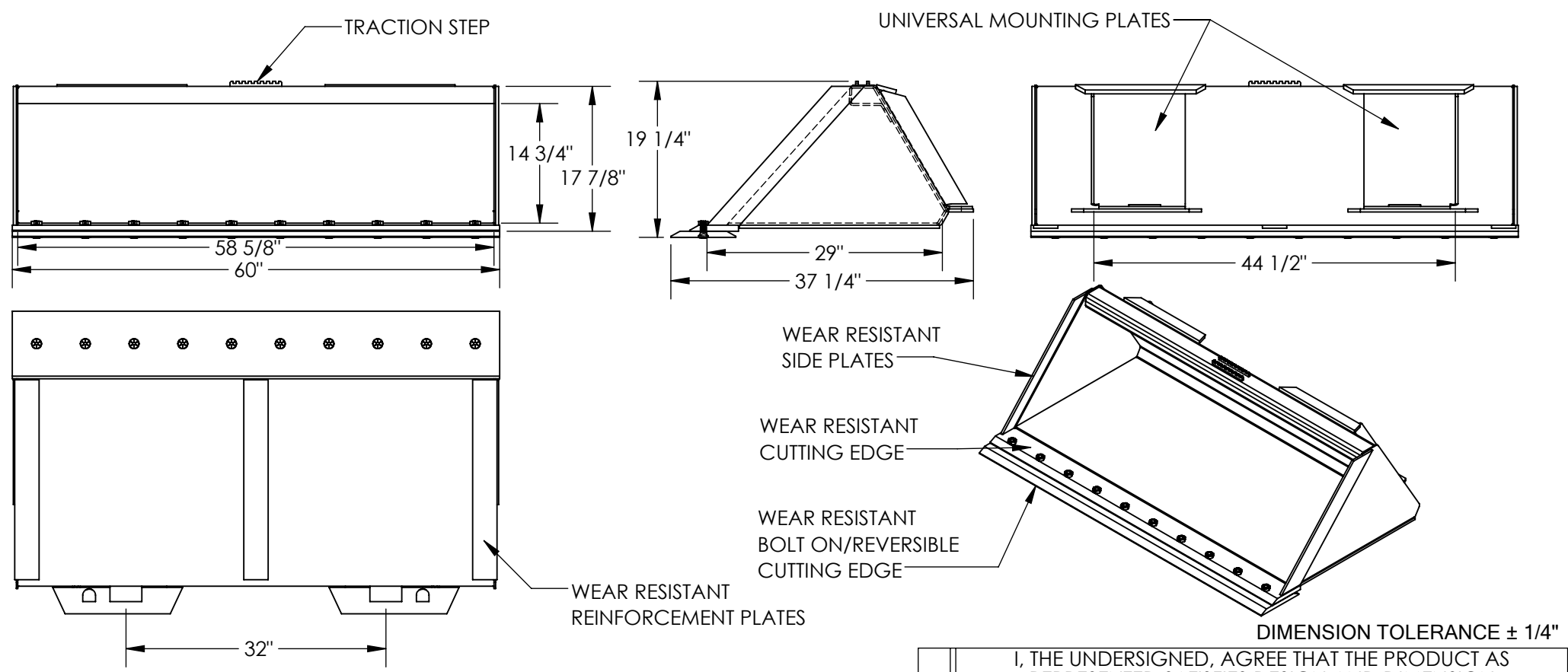

STANDARD FEATURES

- MODEL NUMBER IS EA-SKSB-60-LPX
- OVERALL WIDTH IS 60"
- USEABLE WIDTH IS 58 5/8"
- OVERALL LENGTH IS 37 1/4"
- USEABLE LENGTH IS 29"
- OVERALL HEIGHT IS 19 1/4"
- USEABLE HEIGHT IS 14 3/4"
- UNIVERSAL MOUNTING PLATE
- ON 32" CENTER
- WEAR RESISTANT CUTTING EDGE
- WEAR RESISTANT REINFORCEMENT PLATES ON BOTTOM OF BUCKET
- WEAR RESISTANT SIDE PLATES
- WEAR RESISTANT BOLT ON/REVERSIBLE CUTTING EDGE
- BLACK LIQUID ENAMEL PAINT

SPECIAL FEATURES

NONE

APPROVAL

I, THE UNDERSIGNED, AGREE THAT THE PRODUCT AS REPRESENTED SATISFIES DESIGN AND DIMENSION REQUIREMENTS. I ALSO ACKNOWLEDGE MY DUTY TO CONFIRM PRODUCT AND INSTALLATION COMPLIANCE WITH ALL APPLICABLE FEDERAL, STATE AND LOCAL REGULATIONS AND STANDARDS.

ANY MODIFIED UNITS ARE NON-RETURNABLE

[] As drawn [] As marked

Signed: _____ Date: _____

Printed Name: _____

LEAD TIME WILL START UPON RECEIPT OF SIGNED APPROVAL DRAWING

FOR INTERNAL USE ONLY PROJECT SIGN OFF	
SALES	
ENG.	
FAB.	
POWER	

DISTRIBUTOR'S NAME:		P.O.#
VESTIL MANUFACTURING		X
DRAWN BY: TAW		W.O.#
DATE: 12/29/2017		X
REFERENCE: X	SCALE: 1:18	SALES: X
QUOTED LEAD TIME: X	QUOTE #	FILE NAME:
	X	50-007-008