

The Red Jacket
The Red Jacket AG
Red Armor™
Submersible Turbine Pumps

Installation, Service, & Parts Lists

Red Jacket® Quick-Set® Submersible Pump



Notice

Veeder-Root makes no warranty of any kind with regard to this publication, including, but not limited to, the implied warranties of merchantability and fitness for a particular purpose.

Veeder-Root shall not be liable for errors contained herein or for incidental or consequential damages in connection with the furnishing, performance, or use of this publication.

Veeder-Root reserves the right to change system options or features, or the information contained in this publication.

This publication contains proprietary information which is protected by copyright. All rights reserved. No part of this publication may be photocopied, reproduced, or translated to another language without the prior written consent of Veeder-Root.

Contact Red Jacket Technical Support for additional troubleshooting information at 800-323-1799.

DAMAGE GOODS/LOST EQUIPMENT

Thoroughly examine all components and units as soon as they are received. If any cartons are damaged or missing, write a complete and detailed description of the damage or shortage on the face of the freight bill. The carrier's agent must verify the inspection and sign the description. Refuse only the damaged product, not the entire shipment.

VR must be notified of any damages and/or shortages within 30 days of receipt of the shipment, as stated in our Terms and Conditions.

VEEDER-ROOT'S PREFERRED CARRIER

1. Fax Bill of Lading to V/R Customer Service at 800-234-5350.
2. Call V/R Customer Service at 800-873-3313 with the specific part numbers and quantities that were received damaged or lost.
3. VR will file the claim with the carrier and replace the damaged/missing product at no charge to the customer. Customer Service will work with production facility to have the replacement product shipped as soon as possible.

CUSTOMER'S PREFERRED CARRIER

1. Customer files claim with carrier.
2. Customer may submit a replacement purchase order. Customer Service will work with production facility to have the replacement product shipped as soon as possible.
3. If "lost" equipment is delivered at a later date and is not needed, VR will allow a Return to Stock without a restocking fee.
4. VR will NOT be responsible for any compensation when a customer chooses their own carrier.

RETURN SHIPPING

For the parts return procedure, please follow the instructions in the "General Returned Goods Policy" pages of the "Policies and Literature" section of the Veeder-Root North American Red Jacket Mechanical Products Price Book. Veeder-Root will not accept any return product without a Return Goods Authorization (RGA) number clearly printed on the outside of the package.

Introduction

Overview	1
Safety Precautions	2
Warnings and Instructions	3
Preliminary Precautions.....	3
Requirements For Use	4
Operating Precautions.....	4
Regulatory Approvals	5
Fuel Compatibilities	5
Installation and Manifold Dimensions	6
Recommended Floating Suction Installation	7
Dimensions for Pump Selection	8
Specifications	9

Installation

Attaching the UMP	14
Installing the Pump	16
Wiring Power from the Panel to the Red Jacket STP	21
For Single Phase Pumps with Capacitor	22
For Three Phase Pumps (without Capacitor)	30
Connecting to the External Equipotential Bonding Terminal	31
Installing Two Pumps for Tandem Operation	32
Wiring Single Phase Tandem Pumps	33
Wiring Three Phase Tandem Pumps	34
Siphon Ports	35
Installing a Siphon Assembly	36
Kits Required:	36
Procedure:	36
Installing an Electronic Line Leak Detector Transducer or Mechanical LLD	38
Kits Required:	38
Other Parts:	38
Procedure:	38
Initial Start Up of Pump	39
Pump Tests	40
Verifying Relief Pressure	40
Checking Relief Pressure at the Pump	40
Equipment required:	40
Procedure:	40
Testing the Line	42
Equipment required:	42
Procedure	42
Testing the tank	43
Equipment required:	43
Procedure:	43

Service And Repair

Replacing the UMP	44
Kits Required:	44
Procedure:	44
Replacing the Capacitor in the Manifold for Single Phase Pumps	48
Kits Required:	48
Procedure:	48
Replacing the Check Valve Assembly	49
Kits Required:	49

Procedure:.....	49
Replacing the Conduit Bushing	51
Parts Required:.....	51
Procedure:.....	51
Replacing the Pigtail	52
Kits Required:.....	52
Procedure:.....	52
Replacing the Packer-to-Manifold Wiring Connectors	55
Kits Required:.....	55
Procedure:.....	55
Replacing the Air Purge Screw	60
Kits Required:.....	60
Procedure:.....	60

Parts Lists 65

Customer Service Number	65
Pump Parts	65
Siphon Cartridge Kit Parts	69
Check Valve Housing Kit Parts	70
Check Valve Kit Parts	71
Air Purge Screw Kit Parts	72
Die Spring Kit Parts	73
RA Die Spring Kit Parts	74
Conduit Box Plug Kit Parts	75
Eyebolt Plug Kit Parts	77
Siphon Dummy Plug Kit Parts	78
Manifold Installation Tool Kit	79
RA Touch-Up Paint Kit	80
Powder Coat Protector Kit	81
Conduit Bushing Kit Parts	82
O-Ring Kit Parts	83
Capacitor Kits	84
Electrical Connector Kit Parts	84
Control Boxes	85

Appendix A: Hardware/Seal Kit O-Ring Gauge

Appendix B: Check Valve/Air Purge Screw Operation

Appendix C: ANZEx Conditions Of Certification

Appendix D: FDNY Conditions of Approval

Appendix E: CNEx Conditions of Certification

Figures

Figure 1.	Red Jacket Pac/Man Components And Dimensions	6
Figure 2.	Floating Suction Installation	7
Figure 3.	Floating Suction Adapter	7
Figure 4.	Measuring The Tank (See Table 2 For Adjustment Ranges).	8
Figure 5.	Identifying UMP Models By Their End View	13
Figure 6.	Packer/Manifold With Piping Attaching To UMP	14

Figure 7.	Verifying Pigtail's Female Connector Is Seated Properly	15
Figure 8.	Aligning The UMP Gasket	15
Figure 9.	Utilizing The Manifold Installation Tool With RA Model STPs	16
Figure 10.	Measuring Tank	17
Figure 11.	Loosening Locking Nut	18
Figure 12.	Adjusting Pump Length	18
Figure 13.	Locating Return Line Fitting On Packer	19
Figure 14.	Attaching Return Line Tubing To Pump	19
Figure 15.	Applying Plastic Protectors Onto Covers Prior To Torquing - For All Models With The 'RA' Suffix	20
Figure 16.	Connecting UMP To Packer Wiring	21
Figure 17.	Power Wiring Enters Through Compression Bushing - Single Phase Example Shown	22
Figure 18.	Power Wiring Schematic For Single Phase Pumps	23
Figure 19.	230 Vac Remote Control Box With 110 Vac Coil - Model 880-041-5	23
Figure 20.	Suggested Wiring Diagram Without Optional Control Box	24
Figure 21.	230 Vac Remote Control Box With 110 Vac Coil And Cap - Model 880-045-5/880-046-5	24
Figure 22.	230 Vac Remote Control Box With 230 Vac Coil - Model 880-042-5	25
Figure 23.	Isotrol To IQ System Wiring - 120 Volt Dispenser Signals	26
Figure 24.	Isotrol To IQ System Wiring - 230 Volt Dispenser Signals	27
Figure 25.	Isotrol To IQ W/2HP Capacitor - System Wiring - 120 Volt Dispenser Signals	28
Figure 26.	Isotrol To IQ W/2HP Capacitor - System Wiring - 230 Volt Dispenser Signals	29
Figure 27.	Power Wiring Enters Through Compression Bushing - Three Phase Example Shown	30
Figure 28.	Three Phase Pump Wiring Diagram Examples	31
Figure 29.	Equipotential Bonding Terminal	31
Figure 30.	Tandem Pumps	32
Figure 31.	Suggested Wiring For Single Phase Tandem Pumps	33
Figure 32.	Suggested Wiring For Three Phase Tandem Pumps	34
Figure 33.	Siphon Connection	35
Figure 34.	Siphon Ports	36
Figure 35.	Inserting Siphon Assembly Into Manifold	37
Figure 36.	Locating Discharge Port Plug For Line Leak Transducer	38
Figure 37.	Locating Pump Line Test Port	40
Figure 38.	Service Screw, Line Test Port And Air Purge Screw Locations	42
Figure 39.	Tank Test Port On Manifold	43
Figure 39.	Extractable Lock-Down Nuts	44
Figure 40.	UMP Bolts And Gasket	45
Figure 41.	Verifying Pigtail's Female Connector Is Seated Properly	45
Figure 42.	Locating Packer And Manifold O-Rings	47
Figure 43.	Locating Contractor's Box And Capacitor Compartment	48
Figure 44.	Inserting Check Valve Assembly Into Manifold	50
Figure 45.	Extractable Lock-Down Nuts	52
Figure 46.	Packer-To-Manifold Wiring Connectors	56
Figure 47.	Male Connector's Indexing Pin	56
Figure 48.	Male Connector Index Hole In Base Of Socket	57
Figure 49.	Placing Masking Tape Alignment Marker On Front Of Male Connector	57
Figure 50.	Correct Depth Of Male Connector In Packer Socket	58
Figure 51.	Locating Female Connector Set Screw	59
Figure 52.	Locating Air Purge Screw	60
Figure 53.	Locating Air Purge Screw Hitch Pin	61
Figure 54.	Reorienting The Air Purge Screw's Hitch Pin	62

Figure 55.	Hitch Pin In Position To Install Air Purge Screw	62
Figure 56.	Installing Air Purge Screw Hitch Pin In The Retaining Position	63
Figure 57.	Pump Parts	66
Figure 58.	Siphon Cartridge Kit	69
Figure 59.	Check Valve Housing Kit	70
Figure 60.	Check Valve Kit	71
Figure 61.	Air Purge Screw Kit	72
Figure 62.	Die Spring Kit	73
Figure 63.	RA Die Spring Kit	74
Figure 64.	Conduit Box Plug Kit	75
Figure 65.	RA Conduit Box Plug Kit	76
Figure 66.	Eyebolt Plug Kit	77
Figure 67.	Siphon Dummy Plug Kit	78
Figure 68.	Manifold Installation Tool Kit	79
Figure 69.	RA Touch-Up Paint Kit	80
Figure 70.	Powder Coat Protector Kit	81
Figure 71.	Conduit Bushing	82
Figure 72.	O-Ring Kit	83
Figure 73.	Capacitor Kit	84
Figure 74.	Electrical Connector Kit	85
Figure 75.	880-041-5/880-042-5 Control Box	85
Figure 76.	880-045-5/880-046-5 Control Box	86
Figure B-1.	Pump On Condition	B-1
Figure B-2.	Relief Valve Vents Excess Line Pressure	B-1
Figure B-3.	Locking Down The Check Valve For Line Testing	B-2
Figure B-4.	Removal Of Check Valve Assembly For Service	B-2
Figure B-5.	Returning tHe Check Valve To Its Normal Operating Position	B-3
Figure B-6.	Purging Air From Manifold	B-4

Tables

Table 1.	Maximum Specific Gravity And Maximum Viscosity	5
Table 2.	Distances From Top Of Lifting Screw To Inlet	9
Table 3.	Electrical Service Information (Use For UMPs Containing A Franklin Motor With End View A)	10
Table 4.	Electrical Service Information (Use For UMPs Containing A Faradyne Motor With End View B)	11
Table 5.	UMP Model Dimensions	12
Table 6.	Approximate Pump Shut Off Pressures	12
Table 7.	UMP And Packer/Manifold Combinations	14
Table 8.	Domestic Pump Parts List	65
Table 9.	International Pump Parts List	66
Table 10.	Siphon Cartridge Kits Parts List	69
Table 11.	Check Valve Housing Kits Parts Lists	70
Table 12.	410153-001 Check Valve Kit Parts List	71
Table 13.	410153-002 Hi Pressure Check Valve Kit Parts List	71
Table 14.	410484-001 Air Purge Screw Kit Parts List	72
Table 15.	410485-001 Die Spring Kit Parts List	73
Table 16.	410906-001 RA Die Spring Kit Parts List	74
Table 17.	067-258-5 Conduit Box Plug (STD) Kit Parts List	75
Table 18.	067-259-5 Conduit Box Plug (AG) Kit Parts List	75
Table 19.	410905-001 RA Conduit Box Plug Kit Parts List	76
Table 20.	410482-001 Eyebolt Plug Kit Parts List	77
Table 21.	410482-002 RA Eyebolt Plug Kit Parts List	77
Table 22.	410483-001 AG Siphon Dummy Plug Kit Parts List	78

Table 23.	410483-002 RA Siphon Dummy Plug Kit Parts List	78
Table 24.	410912-001 Manifold Installation Tool Kit Parts List	79
Table 25.	410913-001 RA Touch-Up Paint Kit Parts List	80
Table 26.	410911-001 Powder Coat Protector Kit Parts List	81
Table 27.	410486-001 Conduit Bushing Kit Part List	82
Table 28.	410154-001 O-Ring Kit Parts List	83
Table 29.	Capacitor Kits	84
Table 30.	410165-001 Electrical Connector Kit Parts List	84
Table 31.	880-041-5 Control Box W/115V Coil (60 Hz)	85
Table 32.	880-042-5 Control Box W/230V Coil (50/60 Hz)	86
Table 33.	880-045-5 1/3 And 3/4 HP Control Box W/Cap (115V Coil)	87
Table 34.	880-046-5 All 1-1/2 HP Control Box W/Cap (115V Coil)	87

Introduction

Overview

The Red Jacket submersible turbine pump (STP) is engineered for advanced environmental protection, serviceability, safety, and flow. The Red Jacket STP fits 4-inch NPT threaded, thin-wall risers and is available in a wide variety of horsepower.

The Red Jacket AG (alcohol gas) STP is designed to support alternative fuels. See page 5 for a list of the fuel compatibilities. The Red Jacket Red Armor™ (RA) series submersible turbine pumps are built to last in the harshest corrosive environments created by ULSD and ethanol blends.

Newly designed features of The Red Jacket STP are:

- **Service spill elimination**

The check valve can be raised to provide a larger path to depressurize the line and return fuel to the tank.

- **Vacuum monitoring applications**

The vacuum sensor siphon is a monitoring-grade siphon system. It is designed specifically for use in vacuum monitoring applications, and to integrate with V-R vacuum sensors. The two-port vacuum sensor-siphon system incorporates a redesigned one-piece rubber check valve with an inline filter screen that reduces the clogs and failures that can cause false alarms and downtime in vacuum monitoring applications.

- **Plug-in yoke electrical connection**

Current safety practice when servicing existing STPs requires turning off the circuit breaker, backing off the bolts by up to one inch, and then manually pulling the electrical yoke connection apart. With The Red Jacket STP you turn off the circuit breaker, then simply back off the two nuts holding the extractable in place and the yoke electrical connection is broken as the extractable is removed. After service is complete, the electrical circuit reconnects when the two nuts are retightened. Safe, simple, and easy.

- **Extractable is easy to service**

The Red Jacket STP incorporates industrial die springs that break loose the o-ring seals when the nuts holding the extractable in place are removed. No physical effort or special equipment is required to break the seal. In addition, all connected parts have been moved to the manifold. There is no need to remove parts, leak detectors, or siphons when service or upgrades require removing the extractable.

Utilize the lifting eyebolt to lift out the extractable unit. Removal of the extractable section of the pump must be conducted with caution. Make certain that the extractable section remains centered within the riser pipe and that no portion of the extractable binds during the removal process. If binding occurs during removal, stop and determine the cause of the binding and correct the situation before proceeding with removal.

- **Manifold allows for vertical or horizontal discharge**

The Red Jacket STP has been designed for vertical product discharge via a 2-inch NPT threaded port, but with adequate swinging radius to allow for the addition of an elbow to accommodate a side discharge. In fact, the discharge is now located higher on the manifold so that a side discharge is on the same plane as the rest of the pump.

- **Built-in contractor's box**















An electrical connection housing (contractor's box) is built into The Red Jacket STP's manifold and is completely isolated from the fuel path. Unlike existing systems, there is no adjustment required to fit the yoke, making this pump easy to install.

- **Line leak detection**

Veeder-Root/Red Jacket industry leading pressurized line leak detection (PLLD) provides environmental compliance without the fuel flow restrictions of mechanical (MLLD) or electronic (ELLD) systems.

Safety Precautions

The following safety symbols are used throughout this manual to alert you to important safety hazards and precautions.

 <p>EXPLOSIVE Fuels and their vapors are extremely explosive if ignited.</p>	 <p>FLAMMABLE Fuels and their vapors are extremely flammable.</p>
 <p>ELECTRICITY High voltage exists in, and is supplied to, the device. A potential shock hazard exists.</p>	 <p>TURN POWER OFF Live power to a device creates a potential shock hazard. Turn Off power to the device and associated accessories when servicing the unit.</p>
 <p>WARNING indicates a hazardous situation which, if not avoided, could result in death or serious injury.</p>	 <p>CAUTION indicates a hazardous situation which, if not avoided, could result in minor or moderate injury.</p>
 <p>WEAR EYE PROTECTION Wear eye protection when working with pressurized fuel lines to avoid possible eye injury.</p>	 <p>NOTICE is used to address practices not related to physical injury.</p>
 <p>WEAR GLOVES Wear gloves to protect hands from irritation or injury.</p>	 <p>NO POWER TOOLS Sparks from power tools (such as drills) can ignite fuels and their vapors.</p>
 <p>NO SMOKING Sparks and embers from burning cigarettes or pipes can ignite fuels and their vapors.</p>	 <p>NO OPEN FLAMES Open flames from matches, lighters, welding torches, etc. can ignite fuels and their vapors.</p>
 <p>READ ALL RELATED MANUALS Knowledge of all related procedures before you begin work is important. Read and understand all manuals thoroughly. If you do not understand a procedure, ask someone who does.</p>	 <p>TURN OFF CELL PHONES/PAGERS Sparks from electronic devices in the vicinity of gasoline storage tanks could cause an explosion or fire resulting in bodily injury or death.</p>

⚠ WARNING



This product operates in the highly combustible atmosphere of a gasoline storage tank. **FAILURE TO COMPLY WITH THE FOLLOWING WARNINGS AND SAFETY PRECAUTIONS COULD CAUSE DAMAGE TO PROPERTY, ENVIRONMENT, RESULTING IN SERIOUS INJURY OR DEATH.**

1. All installation work must comply with the latest issue of the National Electrical Code (NFPA 70), the Code for Motor Fuel Dispensing Facilities and Repair Garages (NFPA 30A), and any European, national, state, and local code requirements that apply.
2. Turn off, tag, and lockout power to the STP before connecting or servicing the STP.
3. Before installing pipe threads apply an adequate amount of fresh, UL classified for petroleum, non-setting thread sealant. For AG applications, Loctite 564 is recommended for all field serviceable pipe threads¹.
4. When servicing unit, use non-sparking tools and use caution when removing or installing equipment to avoid generating a spark.
5. To protect yourself and others from serious injury, death, or substantial property damage, carefully read and follow all warnings and instructions in this manual.

¹For the AG Product, the interface connection to the 2" NPT Discharge Port on the manifold was evaluated with steel piping during the UL Listing evaluation and therefore, this material should be used when installing this product. All materials must be fully compatible with the products being stored.

In addition to the specified torque values noted in this manual, when properly tightened, all flanged fittings should have metal-to-metal contact.

Warnings and Instructions



This section introduces the hazards and safety precautions associated with installing, inspecting, maintaining or servicing this product. Before performing any task on this product, read this safety information and the applicable sections in this manual, where additional hazards and safety precautions for your task will be found. Fire, explosion, electrical shock or pressure release could occur and cause damage to property, environment, resulting in serious injury or death, if these safe service procedures are not followed.

PRELIMINARY PRECAUTIONS



You are working in a potentially dangerous environment of flammable fuels, vapors, and high voltage or pressures. Only trained or authorized individuals knowledgeable in the related procedures should install, inspect, maintain or service this equipment.



Read the Manual

Read, understand and follow this manual and any other labels or related materials supplied with this equipment. If you do not understand a procedure, call 1-800-323-1719 to locate a qualified technician. It is imperative to your safety and the safety of others to understand the procedures before beginning work. **Make sure your employees and any service contractors read and follow the instructions.**

Follow the Regulations

Applicable information is available in National Fire Protection Association (NFPA) 30A; *Code for Motor Fuel Dispensing Facilities and Repair Garages*, NFPA 70; *National Electrical Code* (NEC), Occupational Safety and Hazard Association (OSHA) regulations and federal, state, and local codes. All these regulations must be

followed. Failure to install, inspect, maintain or service this equipment in accordance with these codes, regulations and standards may lead to legal citations with penalties or affect the safe use and operation of the equipment.

Prevent Explosions and Fires

Fuels and their vapors will explode or burn, if ignited. Spilled or leaking fuels cause vapors. Even filling customer tanks will cause potentially dangerous vapors in the vicinity of the dispenser or island.

Working Alone

It is highly recommended that someone who is capable of rendering first aid be present during servicing. Familiarize yourself with Cardiopulmonary Resuscitation (CPR) methods, if you work with or around high voltages. This information is available from the American Red Cross. Always advise the station personnel about where you will be working, and caution them not to activate power while you are working on the equipment. Use the OSHA Lockout/Tagout procedures. If you are not familiar with this requirement, refer to OSHA documentation.

Working With Electricity Safely

Ensure that you use safe and established practices in working with electrical devices. Poorly wired devices may cause a fire, explosion or electrical shock. Ensure that grounding connections are properly made. Ensure that you do not pinch wires when replacing covers. Follow OSHA Lockout/Tagout requirements. Station employees and service contractors need to understand and comply with this program completely to ensure safety while the equipment is down. Before you start work, know the location of the Emergency Power Cutoff Switch (the E-STOP). This switch cuts off power to all fueling equipment and submerged turbine pumps and is to be used in the event of an emergency. The buttons on the console at the cashier's station WILL NOT shut off electrical power to the pump/dispenser. This means that even if you press a button on the console labeled EMERGENCY STOP, ALL STOP, PUMP STOP, or something similar, fuel may continue to flow uncontrolled.

Hazardous Materials

Some materials may present a health hazard if not handled correctly. Ensure that you clean hands after handling equipment. Do not place any equipment in the mouth.

⚠ WARNING FAILURE TO COMPLY WITH THE FOLLOWING WARNINGS AND SAFETY PRECAUTIONS COULD RESULT IN PROPERTY DAMAGE, INJURY OR DEATH.



FIRE HAZARD! Do **NOT** use **power tools** (Class I Division I and Class I Division II) during the installation or maintenance of equipment. Sparking could ignite fuel or vapors, resulting in fire.

CHEMICAL EXPOSURE HAZARD! Wear appropriate **safety equipment** during installation or maintenance of equipment. Avoid exposure to fuel and vapors. Prolonged exposure to fuel may cause severe skin irritations and possible burns.

REQUIREMENTS FOR USE

- The Red Jacket is designed for use only at facilities dispensing motor fuels.
- Application of The Red Jacket must be consistent with NFPA Code 30A, OSHA regulations, and federal, state and local fire codes, and other applicable local regulations.
- The selection of any Veeder-Root product must be based upon physical specifications and limitations and the product's compatibility with the materials to be handled. Veeder-Root makes no warranty of fitness for a particular purpose.
- All Veeder-Root products should be used in accordance with applicable federal, state and local laws, ordinances and regulations.



OPERATING PRECAUTIONS

- **NO SMOKING.** Extinguish all open flames and pilot lights, such as on RV appliances.
- **TURN OFF** cell phones and other electronic devices to prevent sparks which could cause an explosion or fire.

Regulatory Approvals

All models of The Red Jacket are UL and cUL listed.

Fuel Compatibilities

Pumps are designed to operate in a Class 1, Group D atmosphere and in accordance with CENELEC standard and the European Directive 2014/34/EU "Equipment for Potentially Explosive Atmosphere" (II 2G Ex IIA T4).

All models of The Red Jacket are UL Listed for the following fuel compatibilities							
Fuel Oil	100% Diesel	100% Gasoline	Gasoline and up to				
			10% Ethanol	15% Methanol	20% MTBE	20% ETBE	20% TAME

All models of The Red Jacket with both the AG prefix and the RJ suffix are UL Listed for the following fuel compatibilities									
Fuel Oil	100% Diesel	Diesel and up to 20% Biodiesel	100% Biodiesel	100% Gasoline	Gasoline and up to				
					85% Ethanol	15% Methanol	20% MTBE	20% ETBE	20% TAME

For Internal Fluid Confining Components, Replace Only With Identical Parts.

The Red Jacket is designed to be compatible with 100 percent gasoline, or diesel and 80 percent gasoline with 20 percent methanol, ethanol, TAME, ETBE, or MTBE. All UMPs and STP Finals having the model numbers including the AG prefix are designed to be compatible with 100 percent gasoline, methanol and 90 percent ethanol with 10 percent gasoline and 80 percent gasoline with 20 percent TAME, ETBE, or MTBE; and 100 percent diesel, diesel and up to 100 percent biodiesel; kerosene, fuel oil, avgas and jet fuel (see Table 1 for UMP models and working parameters).

Table 1. Maximum Specific Gravity And Maximum Viscosity

UMP Model	Maximum Specific Gravity	Maximum Viscosity
AGUMP75S1, UMP75U1	.95	70SSU at 60°F (15°C)
AGUMP150S1, UMP150U1	.95	70SSU at 60°F (15°C)
AGUMP75S3-3, UMP75U3-3	.95	70SSU at 60°F (15°C)
AGUMP150S3-3, UMP150U3-3	.95	70SSU at 60°F (15°C)
X3AGUMP150S1, X3UMP150U1	.87	70SSU at 60°F (15°C)
AGUMP75S17-3, UMP75U17-3	.95	70SSU at 60°F (15°C)
AGUMP150S17-3, UMP150U17-3	.95	70SSU at 60°F (15°C)
X4AGUMP150S17, X4UMP150U17	.86	70SSU at 60°F (15°C)
X4AGUMP150S3, X4UMP150U3	.86	70SSU at 60°F (15°C)
AGUMP200S1-3, AGUMPL200S1-3 UMP200U1-3, UMPL200U1-3	.87	70SSU at 60°F (15°C)
AGP200S3-4, P200U3-4	.87	70SSU at 60°F (15°C)
AGP200S17-4, P200U17-4	.87	70SSU at 60°F (15°C)

The Red Jacket features an adjustable column pipe and electrical conduit that allows the overall length to be adjusted to a wide range of overall pump lengths. By loosening a collet on the column pipe, the length of the pump may be varied by extending or retracting the column pipe. Three sizes of adjustable column pipe are available to cover most pump length requirements (RJ1, RJ2, and RJ3 or RA1, RA2 and RA3).

Installation and Manifold Dimensions

Figure 1 shows several views and dimensions of The Red Jacket Pac/Man.

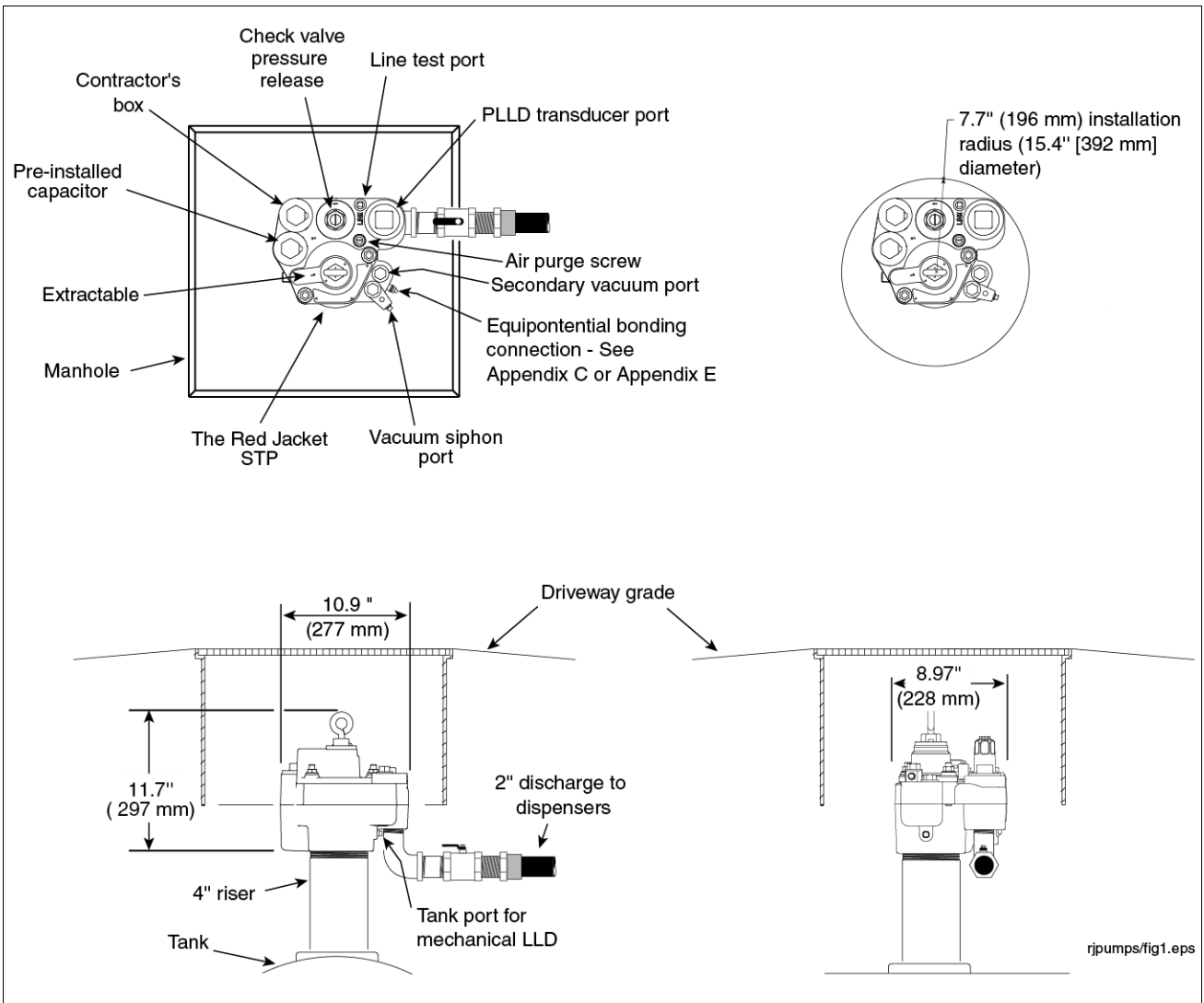

Figure 1. Red Jacket Pac/Man Components And Dimensions

Recommended Floating Suction Installation

Figure 2 is an example of a floating suction installation. The floating suction arm can be mounted to pump previous to installing in tank.

NOTICE Veeder-Root supplies adapter only, not the apparatus.

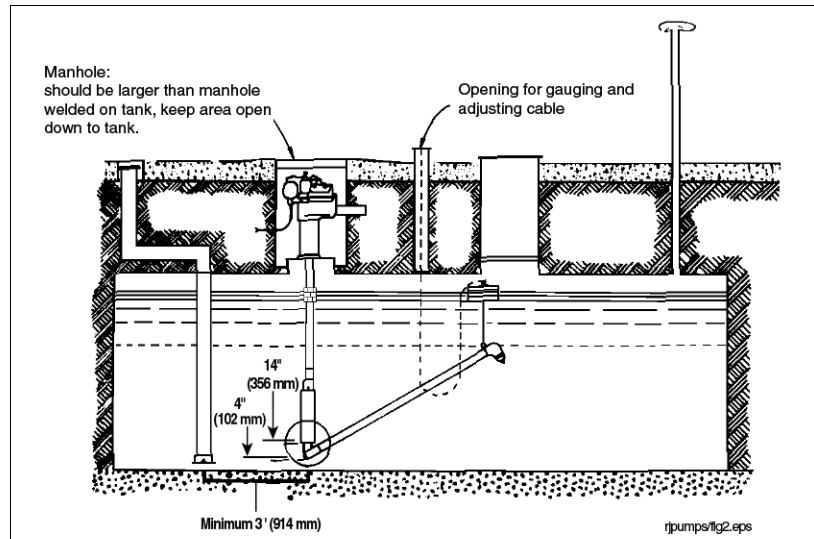

Figure 2. Floating Suction Installation

Figure 3 is an enlarged view within the circle in Figure 2.

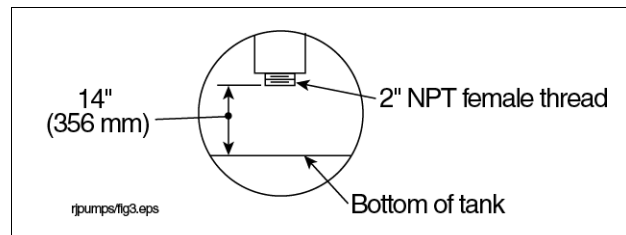

Figure 3. Floating Suction Adapter

Easy service access is provided by unbolting manhole lid through which pump is mounted and removing entire assembly. Use proper thread sealant and insert gasket between flanges of floating suction and pump. This prevents hindrance to pump performance when product level is below this point.

NOTICE The Red Jacket is a centrifugal type pump and is not designed to pump product when the level is below the bottom end of the UMP.

Dimensions for Pump Selection

Figure 4 shows the dimensions needed to ensure a correctly sized pump.

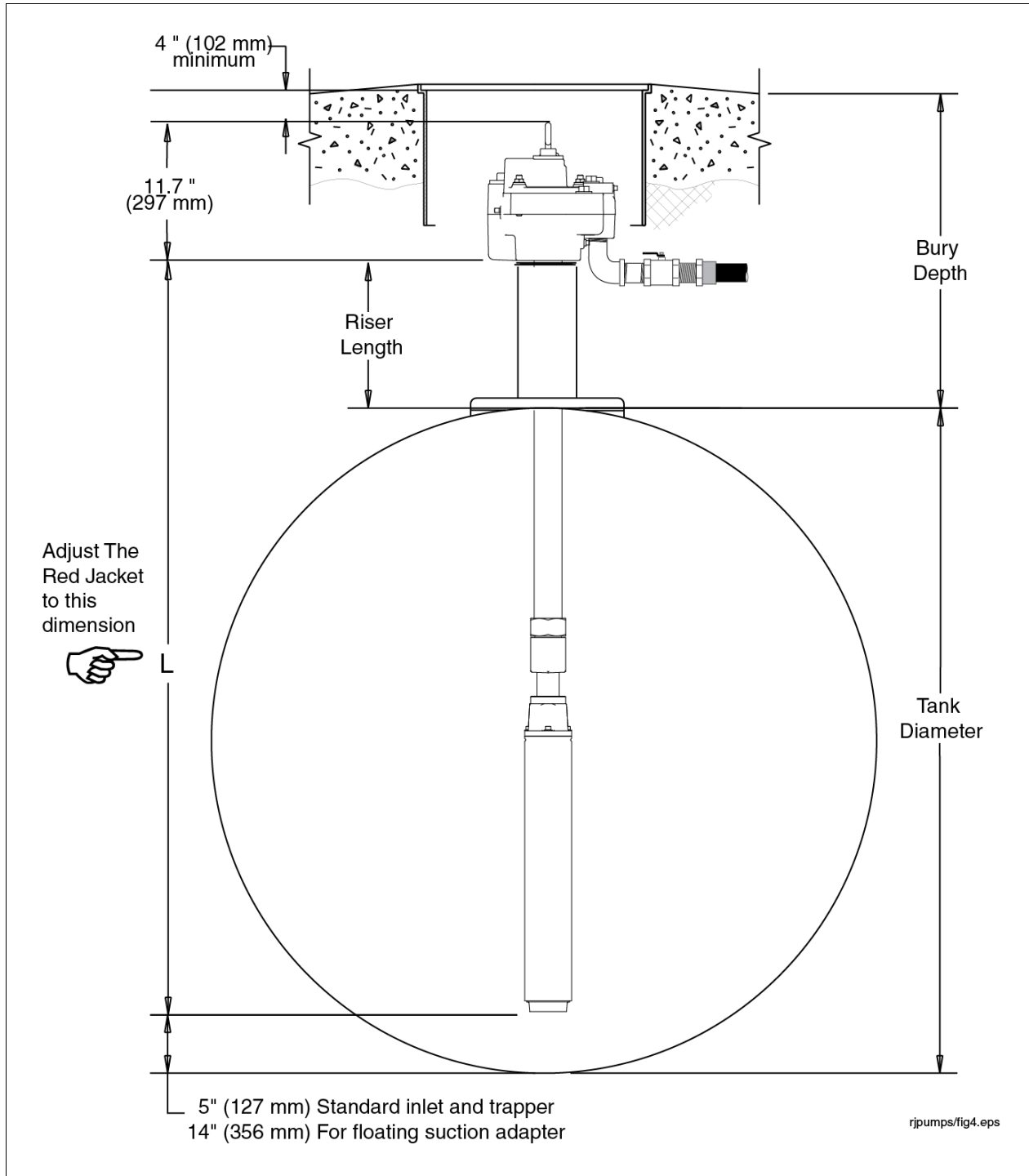

NOTICE Distance between centerline of UMP and centerline of bottom fill tube should be 3 feet (914mm) minimum. Air locking of pump after product delivery may occur at distances less than this.

Specifications

Table 2 shows the adjustable pump lengths by model

Table 2. Distances From Top Of Lifting Screw To Inlet

Model#	Retracted		Extended	
	in.	mm	in.	mm
AGP75S1RJ1, P75U1RJ1, AGP75S1RA1	72.0	1828	102.0	2589
AGP75S1RJ2, P75U1RJ2, AGP75S1RA2	102.0	2590	162.0	4113
AGP75S1RJ3, P75U1RJ3, AGP75S1RA3	162.0	4115	222.0	5637
AGP150S1RJ1, P150U1RJ1, AGP150S1RA1	74.5	1891	105.0	2667
AGP150S1RJ2, P150U1RJ2, AGP150S1RA2	104.5	2653	165.0	4186
AGP150S1RJ3, P150U1RJ3, AGP150S1RA3	164.0	4166	225.0	5710
X3AGP150S1RJ1, X3P150U1RJ1, X3AGP150S1RA1	75.5	1913	105.5	2684
X3AGP150S1RJ2, X3P150U1RJ2, X3AGP150S1RA2	105.5	2675	165.5	4208
X3AGP150S1RJ3, X3P150U1RJ3, X3AGP150S1RA3	165.5	4199	225.5	5732
AGP75S3-3RJ1, P75U3-3RJ1, AGP75S3-3RA1	74.0	1879	104.5	2649
AGP75S3-3RJ2, P75U3-3RJ2, AGP75S3-3RA2	104.0	2641	164.5	4173
AGP75S3-3RJ3, P75U3-3RJ3, AGP75S3-3RA3	164.0	4165	224.5	5697
AGP150S3-3RJ1, P150U3-3RJ1, AGP150S3-3RA1	76.0	1932	106.5	2703
AGP150S3-3RJ2, P150U3-3RJ2, AGP150S3-3RA2	106.0	2694	166.5	4227
AGP150S3-3RJ3, P150U3-3RJ3, AGP150S3-3RA3	166.0	4218	226.5	5751
X4AGP150S3RJ1, X4P150U3RJ1, X4AGP150S3RA1	76.5	1946	107.0	2717
X4AGP150S3RJ2, X4P150U3RJ2, X4AGP150S3RA2	106.5	2708	167.0	4241
X4AGP150S3RJ3, X4P150U3RJ3, X4AGP150S3RA3	166.5	4232	227.0	5765
AGP75S17-3RJ1, P75U17-3RJ1, AGP75S17-3RA1	73.0	1853	103.5	2624
AGP75S17-3RJ2, P75U17-3RJ2, AGP75S17-3RA2	103.0	2615	163.5	4148
AGP75S17-3RJ3, P75U17-3RJ3, AGP75S17-3RA3,	163.0	4139	223.5	5672
AGP150S17-3RJ1, P150U17-3RJ1, AGP150S17-3RA1	75.0	1903	105.5	2674
AGP150S17-3RJ2, P150U17-3RJ2, AGP150S17-3RA2	105.0	2665	165.5	4198
AGP150S17-3RJ3, P150U17-3RJ3, AGP150S17-3RA3	165.0	4189	225.5	5722
X4AGP150S17RJ1, X4AGP150U17RJ1, X4AGP150S17RA1	75.5	1917	106.0	2688
X4AGP150S17RJ2, X4AGP150U17RJ2, X4AGP150S17RA2	105.5	2679	166.0	4212

Table 2. Distances From Top Of Lifting Screw To Inlet

Model#	Retracted		Extended	
	in.	mm	in.	mm
X4AGP150S17RJ3, X4AGP150U17RJ3, X4AGP150S17RA3	165.5	4203	226.0	5736
AGP200S1-3RJ1, P200U1-3RJ1, PL200U1-3RJ1, AGP200S1-3RA1, AGPL200S1-RA1	78.5	1971	108.5	2756
AGP200S1-3RJ2, P200U1-3RJ2, PL200U1-3RJ2, AGP200S1-3RA2, AGPL200S1-RA2	108.5	2733	168.5	4280
AGP200S1-3RJ3, P200U1-3RJ3, PL200U1-3RJ3, AGP200S1-3RA3, AGPL200S1-RA3	168.5	4257	228.5	5804
AGP200S3-4RJ1, P200U3-4RJ1, AGP200S3-4RA1	80.0	2030	110.5	2800
AGP200S3-4RJ2, P200U3-4RJ2, AGP200S3-4RA2	110.0	2790	170.5	4325
AGP200S3-4RJ3, P200U3-4RJ3, AGP200S3-4RA3	170.0	4314	230.5	5850
AGP200S17-4RJ1, P200U17-4RJ1, AGP200S17-4RA1	77.5	1975	108.0	2745
AGP200S17-4RJ2, P200U17-4RJ2, AGP200S17-4RA2	107.5	2735	168.0	4270
AGP200S17-4RJ3, P200U17-4RJ3, AGP200S17-4RA3	167.5	4260	228.0	5790

Table 3 and Table 4 show pump electrical service requirements for UMPs with end views A and B, respectively.

Table 3. Electrical Service Information (Use For UMPs Containing A Franklin Motor With End View A)

Required power supply rating for 60 Hz, 1 phase pumps is 208 - 230 Vac. For 50 Hz, 1 phase pumps, required rating is 220 - 240 Vac. For 3 phase pumps, required rating is 380 - 415 Vac.

UMP Model No.	HP	Hz	PH	Voltage Fluctuation Range		Max. Load Amps	Locked Rotor Amps	Winding Resistance (Ohms)			Capacitor Kit (µF)
				Min.	Max.			Black-Orange	Red-Orange	Black-Red	
AGUMP75S1, UMP75U1	3/4	60	1	200	250	6.5	25	2.9 - 3.6	14.9 - 18.2	17.7 - 21.9	410164-001 (17.5)
AGUMP150S1, UMP150U1	1-1/2	60	1	200	250	10.5	37	2.0 - 2.5	11.6 - 14.2	13.5 - 16.8	410164-002 (25)
X3AGUMP150S1, X3UMP150U1	1/1/2	60	1	200	250	10.5	37	2.0 - 2.5	11.6 - 14.2	13.5 - 16.8	410164-002 (25)
AGUMP200S1-3, AGUMPL200S1-3 UMP200U1-3, UMPL200S1-3	2	60	1	200	250	11.4	46	1.4 - 1.7	2.5 - 3.2	3.8 - 5	410164-003 (40)
AGUMP75S3-3, UMP75U3-3	3/4	50	1	200	250	5.8	17	3.6 - 4.5	20.4 - 25	23.9 - 29.6	410164-001 (17.5)
AGUMP150S3-3, UMP150U3-3	1-1/2	50	1	200	250	10	28	2.5 - 3.1	11.5 - 14	13.9 - 17.2	410164-002 (25)
X4AGUMP150S3, X4UMP150U3	1-1/2	50	1	200	250	10	28	2.5 - 3.1	11.5 - 14	13.9 - 17.2	410164-002 (25)
AGUMP200S3-4, UMP200U3-4	2	50	1	200	250	11	37	1.9 - 2.4	3.1 - 3.9	5.0 - 6.3	410164-003 (40)
AGUMP75S17-3, UMP75U17-3	3/4	50	3	342	457	2.2	8	25.8 - 32.4	25.8 - 32.4	25.8 - 32.4	---
AGUMP150S17-3, UMP150U17-3	1-1/2	50	3	342	457	3.8	15	13.1 - 16.4	13.1 - 16.4	13.1 - 16.4	---
X4AGUMP150S17, X4UMP150U17	1-1/2	50	3	342	457	3.8	15	13.1 - 16.4	13.1 - 16.4	13.1 - 16.4	---
AGUMP200S17-4, UMP200U17-4	2	50	3	342	457	5.0	22	9.3 - 11.6	9.3 - 11.6	9.3 - 11.6	---

Table 4. Electrical Service Information (Use For UMPs Containing A Faradyne Motor With End View B)

Required power supply rating for 60 Hz, 1 phase pumps is 208 - 230 Vac. For 50 Hz, 1 phase pumps, required rating is 220 - 240 Vac. For 3 phase pumps, required rating is 380 - 415 Vac.

UMP Model No.	HP	Hz	PH	Voltage Fluctuation Range		Max. Load Amps	Locked Rotor Amps	Winding Resistance (Ohms)			Capacitor Kit (µF)
				Min.	Max.			Black-Orange	Red-Orange	Black-Red	
AGUMP75S1, UMP75U1	3/4	60	1	200	250	6.5	19	4.7 - 5.7	7.1 - 8.6	11.7 - 14.1	410164-001 (17.5)
AGUMP150S1, UMP150U1	1-1/2	60	1	200	250	10.5	33	2.8 - 3.4	6.8 - 8.2	9.4 - 11.3	410164-002 (25)
X3AGUMP150S1, X3UMP150U1	1/1/2	60	1	200	250	10.5	33	2.8 - 3.4	6.8 - 8.2	9.4 - 11.3	410164-002 (25)
AGUMP200S1-3, AGUMPL200S1-3 UMP200U1-3, UMPL200U1-3	2	60	1	200	250	11.4	44	1.9 - 2.3	3.4 - 4.1	5.1 - 6.2	410164-003 (40)
AGUMP75S3-3, UMP75U3-3	3/4	50	1	200	250	5.8	18	5.2 - 6.3	10.3 - 12.5	15.4 - 18.6	410164-001 (17.5)
AGUMP150S3-3, UMP150U3-3	1-1/2	50	1	200	250	10	31	2.8 - 3.4	13.4 - 16.3	16.1 - 19.5	410164-002 (25)
X4AGUMP150S3, X4UMP150U3	1-1/2	50	1	200	250	10	31	2.8 - 3.4	13.4 - 16.3	16.1 - 19.5	410164-002 (25)
AGUMP200S3-4, UMP200U3-4	2	50	1	200	250	11	38	2.2 - 2.6	6.0 - 7.3	8.0 - 9.7	410164-003 (40)
UMP Model No.	HP	Hz	PH	Voltage Fluctuation Range		Max. Load Amps	Locked Rotor Amps	Winding Resistance (Ohms)			Setting on Motor Protection Device
				Min.	Max.			Black-Orange	Red-Orange	Black-Red	
AGUMP75S17-3, UMP75U17-3	3/4	50	3	342	457	2.2	8.1	24.4 - 29.6	24.4 - 29.6	24.4 - 29.6	1.8
AGUMP150S17-3, UMP150U17-3	1-1/2	50	3	342	457	3.8	14.1	12.1 - 14.7	12.1 - 14.7	12.1 - 14.7	3.8
X4AGUMP150S17, X4UMP150U17	1-1/2	50	3	342	457	3.8	14.1	12.1 - 14.7	12.1 - 14.7	12.1 - 14.7	3.8
AGUMP200S17-4, UMP200U17-4	2	50	3	342	457	5.0	17.7	9.9 - 12.0	9.9 - 12.0	9.9 - 12.0	4.5

When using a Red Jacket IQ™ Control Unit with an UMP containing a Faradyne motor, IQ software 805-001C (Version 3.2) or newer, is required for proper operation of the system. The UMPs will have an 'FM' designation printed on the UMP shell. Software upgrade kit part number is 410600-001.

Table 5 lists UMP weights and lengths and Table 6 lists pump shut off pressures.

NOTICE The weights and lengths listed below are approximate values and will vary due to manufacturing tolerances.

The optional trapper intake screen is available as a field installed accessory. Trapper options will increase the length of the UMP by 3.3 inches (83 mm). For installation instructions, see Red Jacket installation instructions #051-256-1. For models with floating suction adapter, add 2-3/8 inches (59 mm) and 4 pounds (1.8 kg).

Table 5. UMP Model Dimensions

UMP Model	HP	Franklin Motor (Use these lengths for UMPs with end view A shown in Figure 5)		Faradyne Motor (Use these lengths for UMPs with end view B shown in Figure 5)		Weight	
		in.	mm	in.	mm	lb.	kg
UMP75U1, AGUMP75S1	3/4	17-3/4	447	17-5/8	448	28	12.7
UMP75U3-3, AGUMP75S3-3	3/4	20	507	19-7/8	505	30.5	13.9
UMP75U17-3, AGUMP75U17-3	3/4	19-1/4	489	19	483	28	12.7
UMP150U1, AGUMP150S1	1-1/2	20-1/2	519	20-5/8	524	34	15.5
X3P150U1, X3AGUMP150S1	1-1/2	21-1/4	540	21-1/2	546	35	15.8
UMP150U3-3, AGUMP150S3-3	1-1/2	22-1/4	565	22-1/4	565	34	15.5
X4P150U3, X4GUMP150S3	1-1/2	22-3/4	576	22-7/8	581	35	15.9
UMP150U17-3, AGUMP150S17-3	1-1/2	21	532	21-1/4	540	31	14.1
X4P150U17, X4AGUMP150S17	1-1/2	21-1/2	547	21-3/4	552	32	14.5
UMP200U1-3, UMPL200U1-3 AGUMP200S1-3, AGUMPL200S1-3	2	24-1/4	618	24-5/8	626	36	16.3
UMP200U3-4, AGUMP200S3-4	2	26	660	26-1/4	667	38	17.2
UMP200U17-4, AGUMP200S17-4	2	23-3/4	600	23-3/4	603	36	16.3

Table 6. Approximate Pump Shut Off Pressures

UMP Model	Approximate Shut Off Pressure
AGUMP75S1, UMP75U1	28 psi (193 kPa) .74 SG @ 60°F (15°C)
AGUMP150S1, UMP150U1	30 psi (207 kPa) .74 SG @ 60°F (15°C)
X3AGUMP150S1, X3UMP150U1	43 psi (297 kPa) .74 SG @ 60°F (15°C)
AGUMP75S3-3, UMP75U3-3	30 psi (207 kPa) .74 SG @ 60°F (15°C)
AGUMP75S17-3, UMP75U17-3	29 psi (200 kPa) .74 SG @ 60°F (15°C)
AGUMP150S3-3, UMP150U3-3	32 psi (220 kPa) .74 SG @ 60°F (15°C)
AGUMP150S17-3, UMP150U17-3	32 psi (220 kPa) .74 SG @ 60°F (15°C)
X4AGUMP150S3, X4UMP150U3	40 psi (275 kPa) .74 SG @ 60°F (15°C)
X4AGUMP150S17, X4UMP150U17	39 psi (267 kPa) .74 SG @ 60°F (15°C)
UMPL200U1-3, AGUMPL200S1-3	36 psi (248 kPa) .74 SG @ 60°F (15°C)
AGUMP200S1-3, UMP200U1-3	43 psi (297 kPa) .74 SG @ 60°F (15°C)
AGUMP200S3-4, UMP200U3-4	43 psi (297 kPa) .74 SG @ 60°F (15°C)
AGUMP200U17-4, UMP200U17-4	43 psi (297 kPa) .74 SG @ 60°F (15°C)

Figure 5 identifies UMP models by their end view.

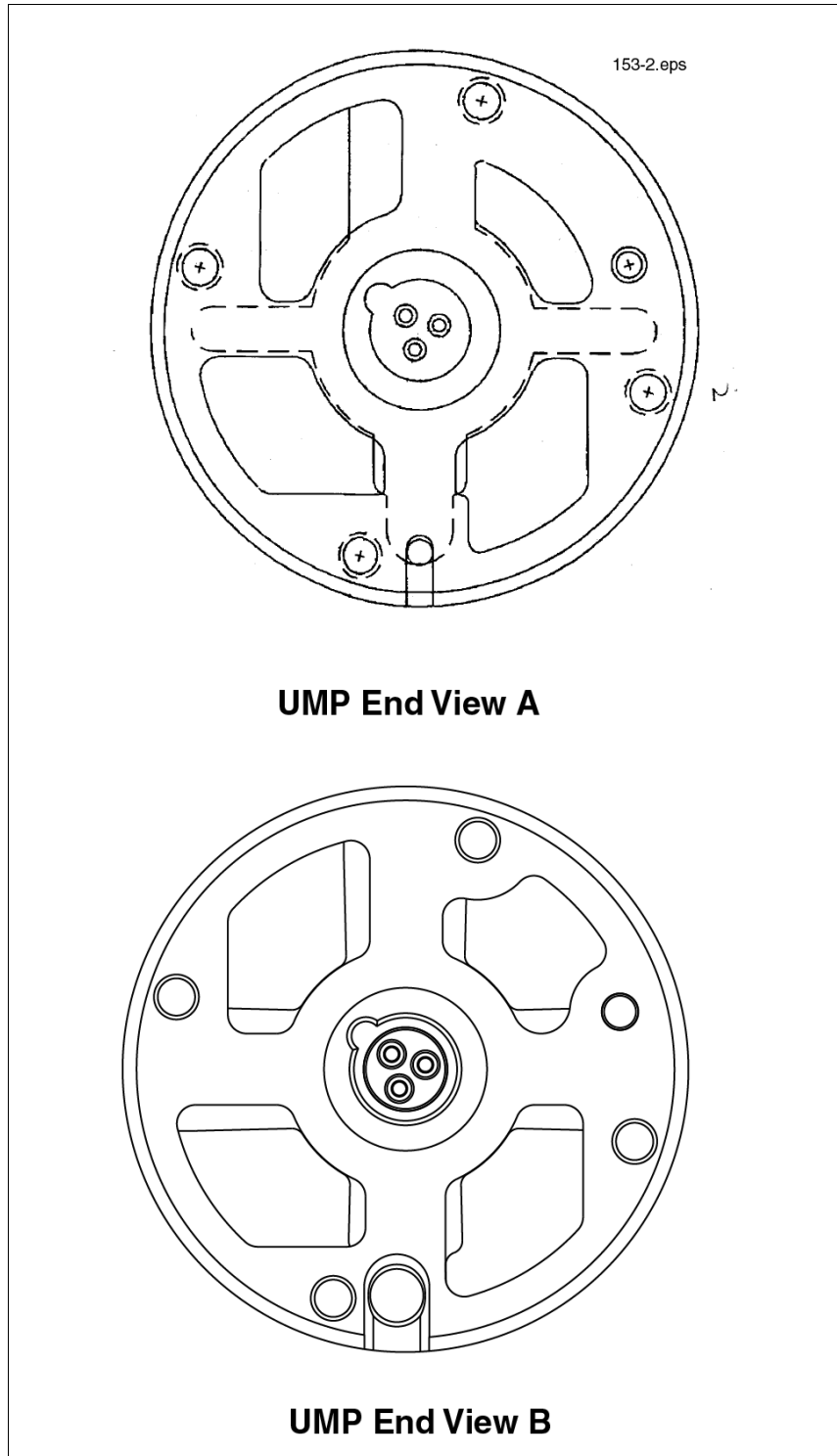

Figure 5. Identifying UMP Models By Their End View

Installation

Attaching the UMP

Table 7 lists the applicable UMPs for each Packer/Manifold.

Table 7. UMP And Packer/Manifold Combinations

Packer/Manifold	UMP	Packer/Manifold	UMP
AGP75S1RJ1, RJ2, RJ3, RA1, RA2, RA3	AGUMP75S1	P150U3-3RJ1, RJ2, RJ3	UMP150U3-3
P75U1RJ1, RJ2, RJ3	UMP75U1	X4AGP150S3RJ1, RJ2, RJ3, RA1, RA2, RA3	X4AGUMP150S3
AGP150S1RJ1, RJ2, RJ3, RA1, RA2, RA3	AGUMP150S1	X4P150U3RJ1, RJ2, RJ3	X4UMP150U3
P150U1RJ1, RJ2, RJ3	UMP150U1	AGP75S17-3RJ1, RJ2, RJ3, RA1, RA2, RA3	AGUMP75S17-3
X3AGP150S1RJ1, RJ2, RJ3, RA1, RA2, RA3	X3AGUMP150S1	P75U17-3RJ1, RJ2, RJ3	UMP75U17-3
X3P150U1RJ1, RJ2, RJ3	X3UMP150U1	AGP150S17-3RJ1, RJ2, RJ3, RA1, RA2, RA3	AGUMP150S17-3
AGP75S3-3RJ1, RJ2, RJ3, RA1, RA2, RA3	AGUMP75S3-3	P150U17-3RJ1, RJ2, RJ3	UMP150U17-3
AGP200S1-3RJ1, RJ2, RJ3, RA1, RA2, RA3	AGUMP200S1-3	X4AGP150S17RJ1, RJ2, RJ3, RA1, RA2, RA3	X4AGUMP150S17
AGPL200S1-3RJ1, RJ2, RJ3, RA1, RA2, RA3	AGUMPL200S1-3	X4P150U17RJ1, RJ2, RJ3	X4UMP150U17
P75U3-3RJ1, RJ2, RJ3	UMP75U3-3	P200U1-3RJ1, RJ2, RJ3	UMP200U1-3
AGP150S3-3RJ1, RJ2, RJ3, RA1, RA2, RA3	AGUMP150S3-3	PL200U1-3RJ1, RJ2, RJ3	UMPL200U1-3
AGP200S3-4RJ1, RJ2, RJ3, RA1, RA2, RA3	AGUMP200S3-4	P200U3-4RJ1, RJ2, RJ3	UMP200U3-4
AGP200S17-4RJ1, RJ2, RJ3, RA1, RA2, RA3	AGUMP200S17-4	P200U17-4RJ1, RJ2, RJ3	UMP200U17-4

The UMP is identified by the model number marked on the shell. The packer/manifold with piping is identified by the catalog number on the packer nameplate. The hardware kit consists of four 5/16-18 x 1" socket head cap screws, four 5/16 lock washers and one discharge head gasket identified by the kit number 144-327-4 (P/N 410818-001 for AG version) marked on the bag (see Figure 6).

The UMP attaches to the packer/manifold column piping discharge head using hardware kit number 144-327-4 (P/N 410818-001 for AG version).



When servicing unit, use non-sparking tools.

NOTICE For all models with the 'RA' suffix, take care not to damage the powder coating on the packer/manifold and discharge head when placing the pump on the working surface.

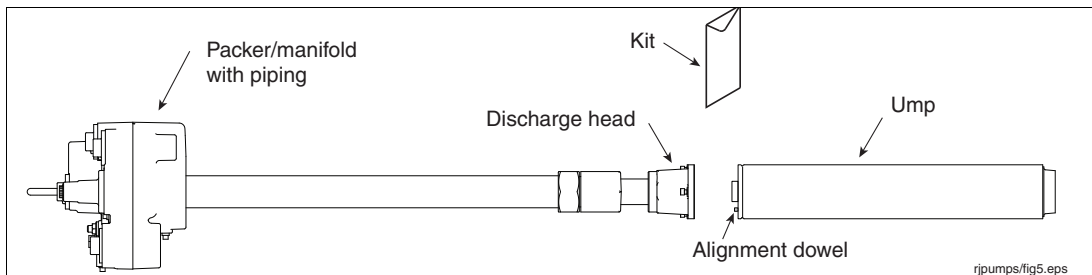

Figure 6. Packer/Manifold With Piping Attaching To UMP

1. Visually inspect the pigtail connector in the end of the discharge head. Be certain the pigtail connector is seated in its socket and its index tab is in the socket's notch (see Figure 7).

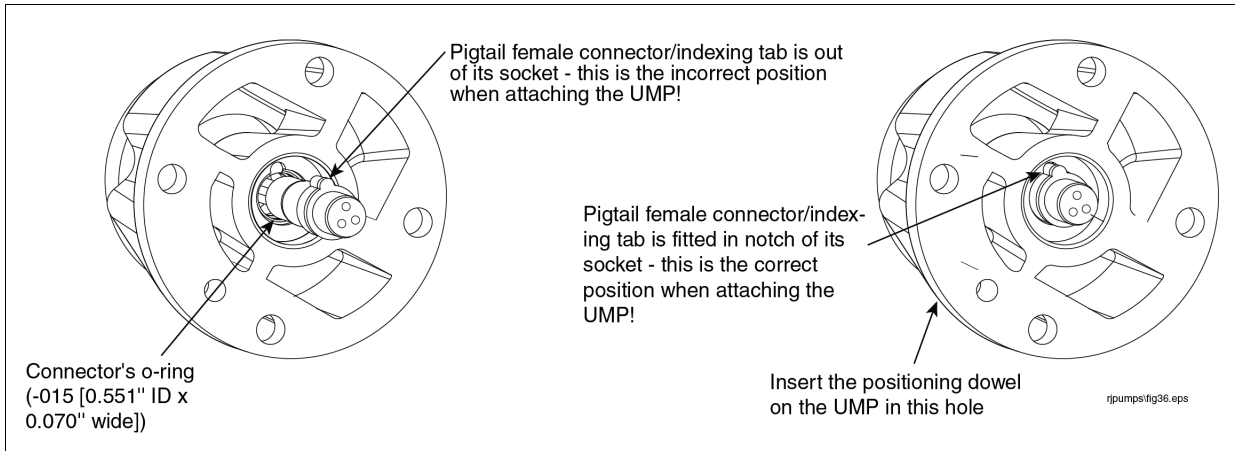

Figure 7. Verifying Pigtail's Female Connector Is Seated Properly

2. Place the new gasket on the new UMP so that all holes align (see Figure 8).

CAUTION Gaskets from competitive UMPs will not seal properly and performance will be reduced.

3. Align the UMP positioning dowel insert in the proper hole in the discharge head (see Figure 7) and push the UMP into position using hand force only. The UMP should be snug against the discharge head prior to installing the UMP retaining bolts.

WARNING Use hand force to push the UMP onto the discharge head. If the UMP does not seat snug against the discharge head, remove the UMP and correct the problem.

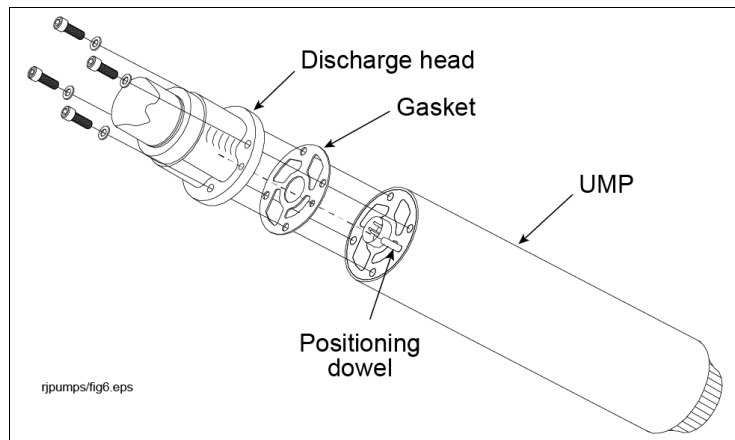

Figure 8. Aligning The UMP Gasket

4. Install the UMP retaining bolts and lock washers (see Figure 8). Snug and then torque the bolts using a cross pattern. Torque to 7 ft-lbs (11 N•m).

WARNING Do not use the bolts to pull the UMP into position. Use the cross pattern to snug and torque bolts. Do not over torque the bolts. Not following instructions may cause parts to fail.

Installing the Pump

- The Red Jacket STP is designed to operate in a Class 1, Group D atmosphere.
 - The manufacturer may recommend new specification and installation instructions.
 - The product temperature must not exceed 105°F (41°C) because the thermal overload protectors in the submersible motor may trip.
1. Before installing pipe threads apply an adequate amount of fresh, UL classified for petroleum, non-setting thread sealant. For AG applications, Loctite 564 is recommended for all field serviceable pipe threads. Tighten the riser pipe in the tank until watertight.

NOTICE For all models with the 'RA' suffix, do not wrench on the powder coated packer/manifold, this may damage the coating and cause corrosion. Use the manifold installation tool (P/N 410912-001) to tighten the manifold onto the riser pipe. Place the installation tool over the two lock-down studs as shown in Figure 9. If installation tool handle needs to be extended, procure a piece of square tubing and slide it over the vertical handle. Secure using the cotter pin.

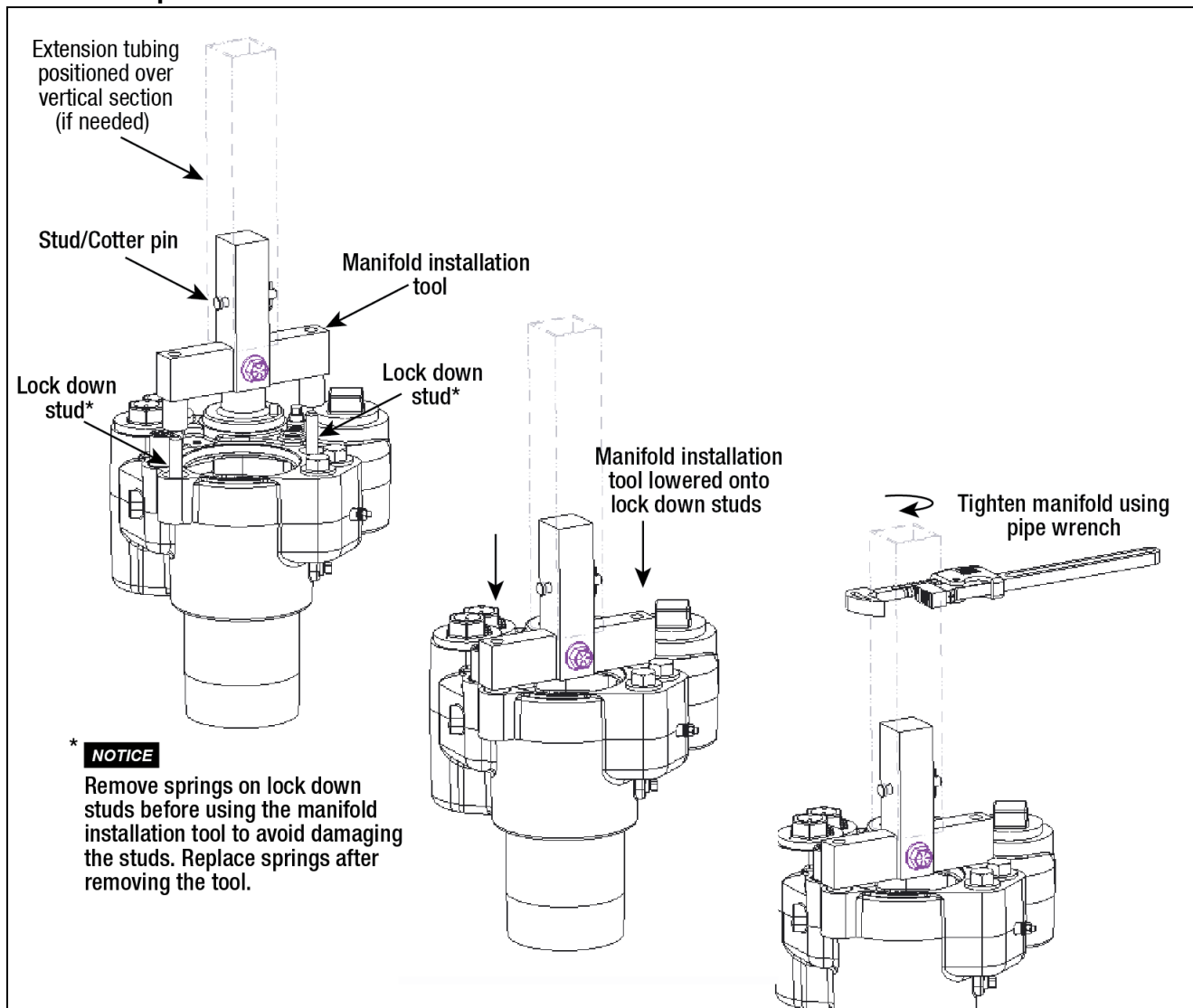

Figure 9. Utilizing The Manifold Installation Tool With RA Model STPs

2. Measure the distance from the bottom of the tank to the top of the 4-inch riser pipe as shown in Figure 10.
Note: For fixed-length pumps, skip to Step 7.

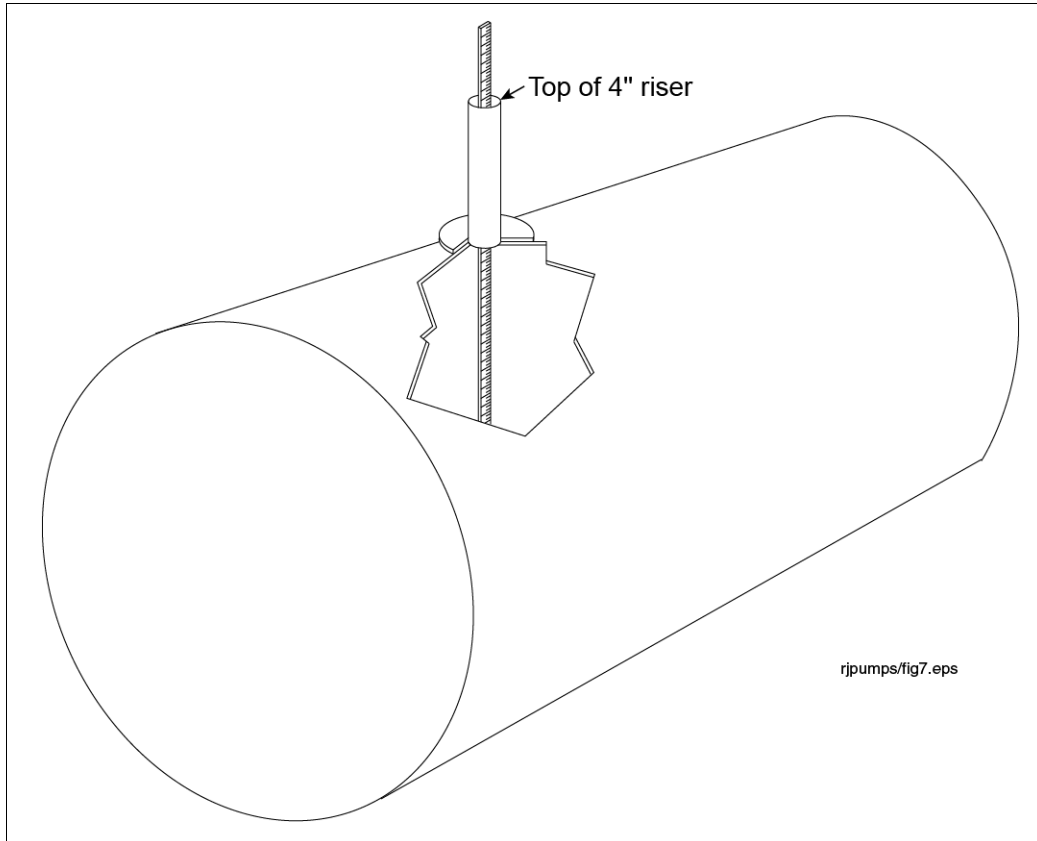

Figure 10. Measuring Tank

3. Uncoil the pigtail at the top of the packer and lay it flat so it will feed into the packer without knotting or kinking.
4. Loosen the clinch assembly on the column pipe by unscrewing the set screw in the side of locking nut, then backing off the locking nut (see Figure 11).

NOTICE A slight twisting of the UMP will loosen the seals and facilitate adjusting it to the correct length. Do not rotate piping beyond 1/4 turn.

For all models with the 'RA' suffix, stainless steel lock-down nuts and washers are used and found in the kit. Apply anti-seize (also found in the kit) to the lock-down studs prior to nut and washer installation.

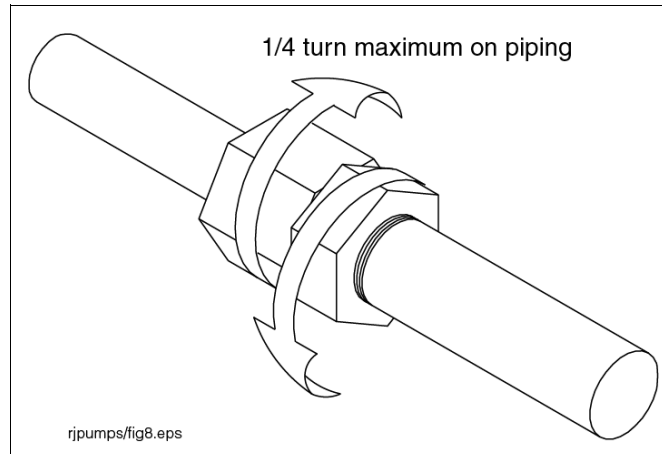

Figure 11. Loosening Locking Nut

5. Referencing Figure 12, pull the UMP end until the distance between the bottom of the manifold and the bottom of the UMP is 5 inches (125 mm) (15 inches [381 mm] for floating suction) shorter than the distance measured in Step 2.

NOTICE If UMP is equipped with floating suction adapter, see section entitled “Recommended Floating Suction Installation” on page 7.

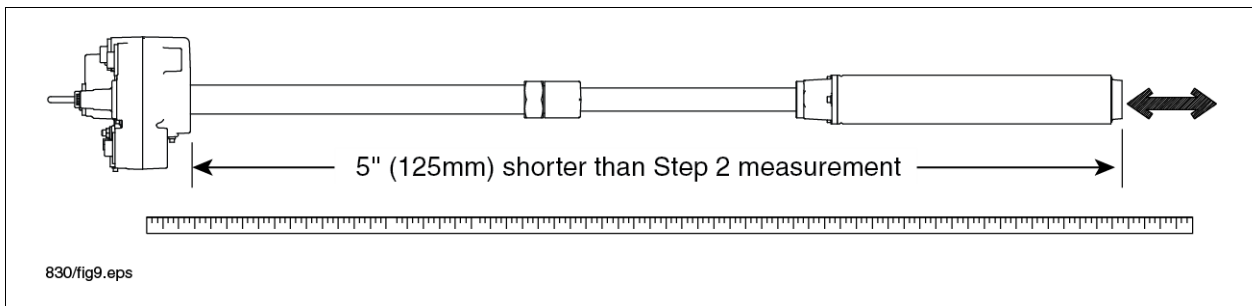

Figure 12. Adjusting Pump Length

⚠ WARNING Take care not to damage the pigtail. If pump is to be adjusted shorter, keep tension on the pigtail to eliminate kinking.

6. Tighten the column pipe locking nut and torque to 150 ft-lbs (200 N•m) minimum, then torque the set screw in the locking nut to 30 - 35 in. lb. (3.5 - 4 N•m). For all models with the ‘RA’ suffix, a stainless steel locking nut with three set screws is used. Torque all set screws in the locking nut to 9 - 11 ft-lbs. (12.2 - 15 N•m).
7. Attach the siphon return line tubing to barbed fitting in the base of packer and secure with a clamp (see Figure 13).

NOTICE Return line should be installed on every application to reduce nuisance trips of electronic tank monitoring.

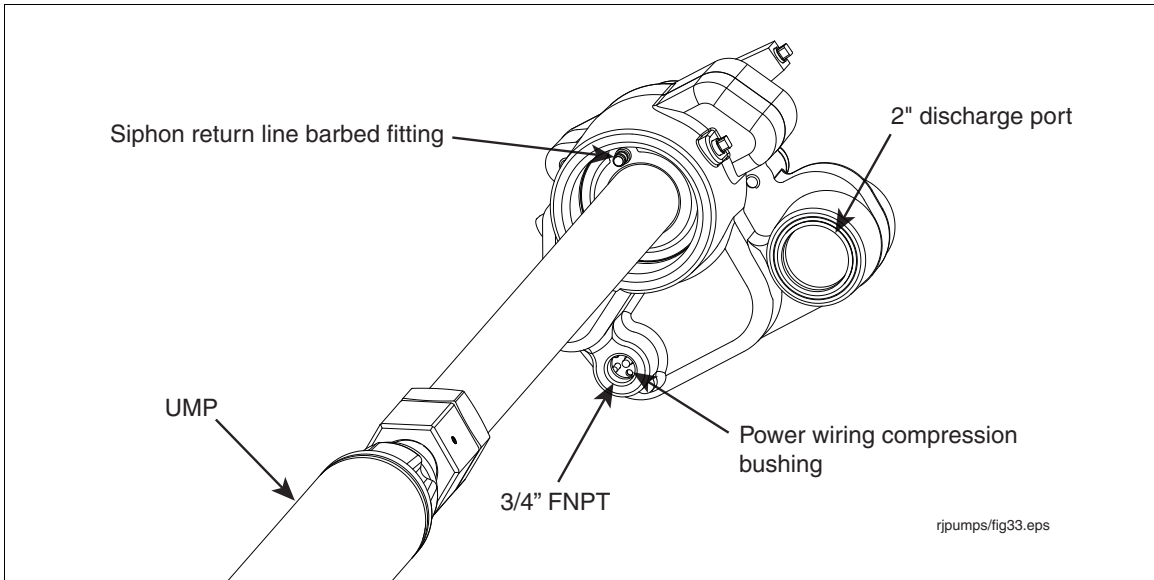

Figure 13. Locating Return Line Fitting On Packer

8. Lay the siphon return line tubing beside the column pipe. Stop 1 - 3 inches (25 - 76 mm) above the discharge head.
9. Secure the siphon return line tubing to the column pipe with tie straps. Locate the tie straps approximately 6 inches (152 mm) from manifold, 6 inches from discharge head and in the middle of the tubing (see Figure 14).

NOTICE Do not overtighten tie straps as a pinched or flattened return line will restrict flow, interfering with proper operation of siphon system.

Note: For fixed-length pumps, skip to Step 14.

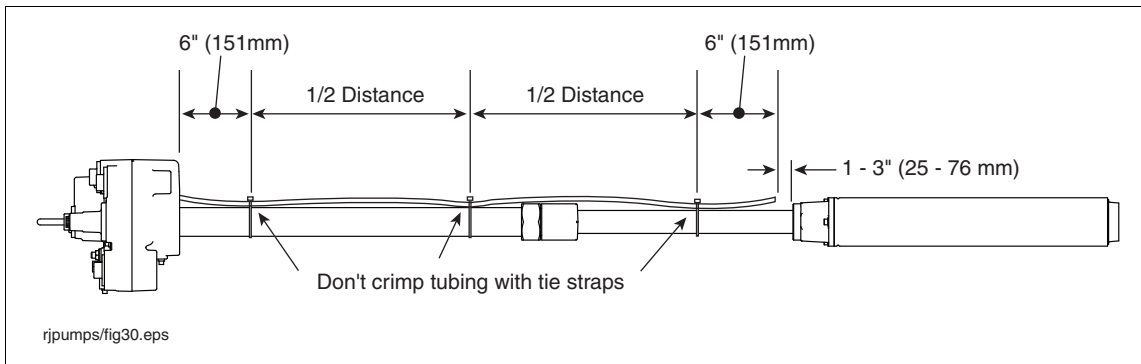

Figure 14. Attaching Return Line Tubing To Pump

10. Pull on the pigtail wires where they exit the packer wiring compartment. Snip pigtail wires approximately 8 inches (200 mm) beyond top of packer.
11. There will be three wires from the male connector installed in the packer's housing and from the three-wire pigtail from the UMP.
12. Strip insulation off all six wires 3/8 inch (10 mm).

13. Connect like colored wires from the UMP to like colored wires from the male connector with wire nuts. When finished connecting the wires, neatly coil wires inside the packer's wiring compartment (see Figure 16).
14. Lubricate the o-ring on the packer wiring compartment cover (with lifting eyebolt) with petroleum based jelly. Screw in the packer wiring compartment cover (thread sealant should not be used). Torque to 35 ft-lbs (50 N•m).

NOTICE For all models with the 'RA' suffix, place the supplied plastic protector on the packer wiring compartment cover prior to torquing (see Figure 15). By not using the protector, damage may occur to the powder coating, causing corrosion.

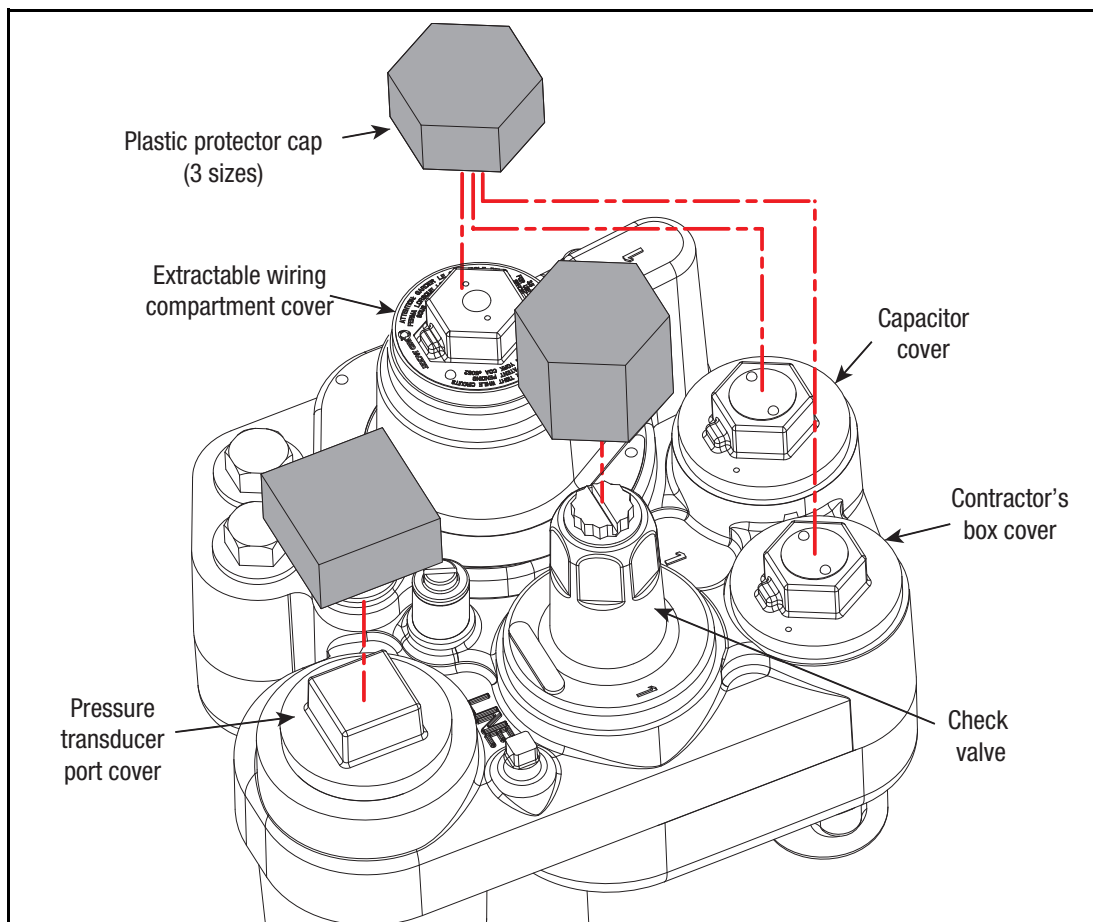

Figure 15. Applying Plastic Protectors Onto Covers Prior To Torquing - For All Models With The 'RA' Suffix

WARNING Confirm that the lifting eyebolt is properly torqued to 10 ft-lbs (13.6 N•m) with a minimum of 6 full threads installed. Occasionally, eyebolts are removed after pump installation and corrosion may occur in the threaded areas of the wiring compartment cover (eyebolt plug) and the eyebolt. If corrosion has occurred, the cover and eyebolt should be replaced.

15. Utilize the lifting eyebolt to suspend the pump vertically and then install the pump onto the riser pipe using UL classified for petroleum, non-setting thread sealant until watertight and align appropriately to connect to the product line piping. For AG applications, Loctite 564 is recommended for all field serviceable pipe threads.



When servicing equipment, use non-sparking tools and use caution when removing or installing equipment to avoid generating a spark.

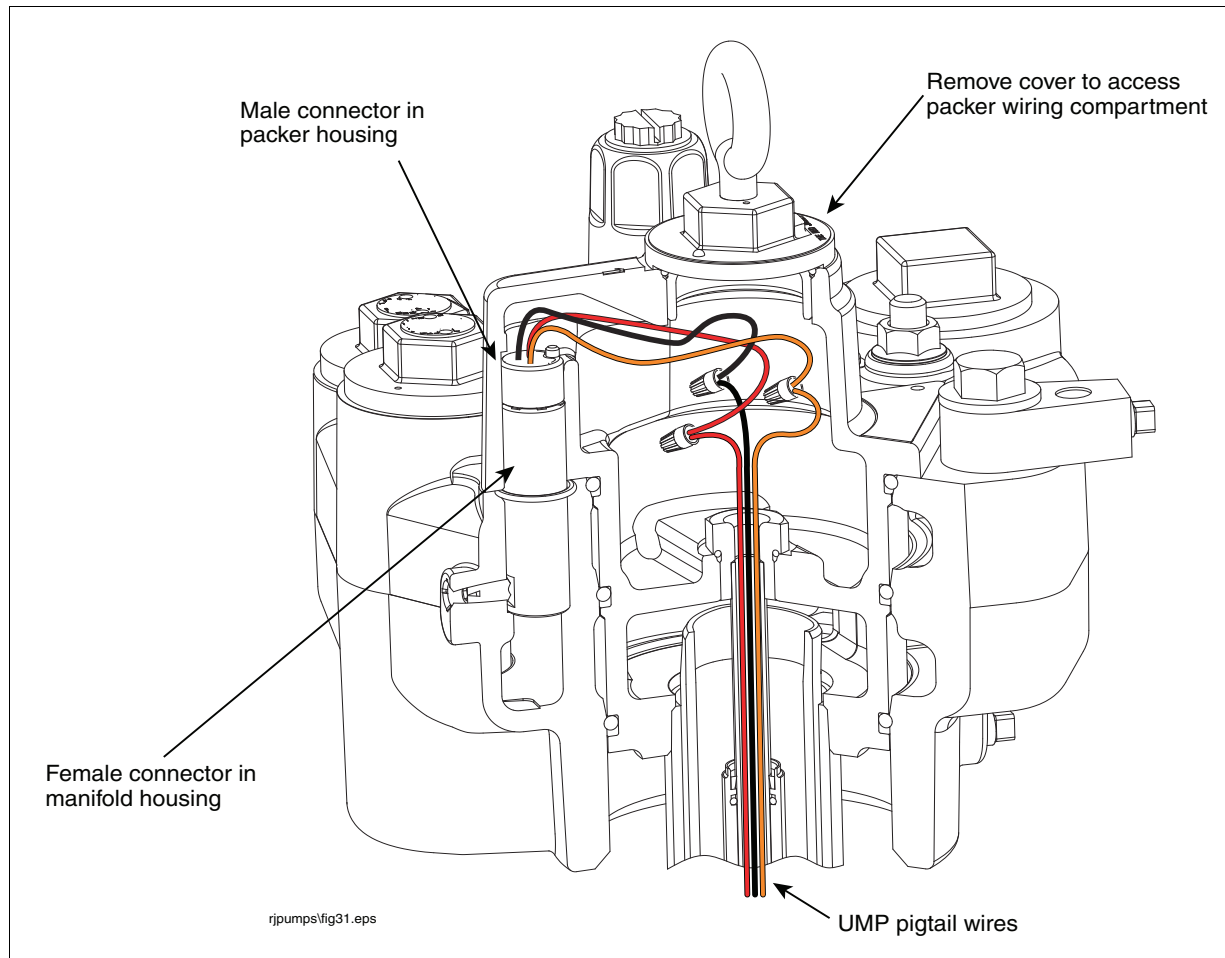

Figure 16. Connecting UMP To Packer Wiring

Wiring Power from the Panel to the Red Jacket STP



Disconnect, lock out, and tag power at the panel before servicing the pump.

1. Connect electrical conduit approved fittings to power wiring entry at base of manifold's contractors box (see cutaway example in Figure 17 for single phase power wiring or Figure 27 for three phase power wiring).



For installations requiring ATEX approval, the end user must use an ATEX Ex d IIA certified cable gland or stopping box.

Use suitable AUS EX, ANZEx or IECEx certified cable gland or flameproof entry device when equipment is installed in accordance with ANZEx certification for connection of the external circuit conductors to the motor conductors used to close the 3/4" NPT conduit connection.

2. Loosen the two screws in the compression bushing just enough so you can remove the bushing from its socket in the bottom of the manifold's contractor box (see Figure 17). Continue lifting up the bushing until it is accessible. Notice that the top plate of the bushing assembly (facing into the manifold) has a larger diameter than the bottom plate, and that there are two open holes and three holes with plastic rod inserts. The plastic inserts seal the bushing and must remain in any unused hole. For example, bringing three wires from the power panel, use the two empty holes and remove and discard one of the two smaller diameter plastic inserts for the

third wire. Push each of the incoming power wires through the empty holes in the bushing assembly. Slide the bushing assembly down over the power wires until it seats in its socket in the base of the manifold's contractor box and then tighten the two screws in bushing assembly securely to compress the bushing and seal the wiring entry.

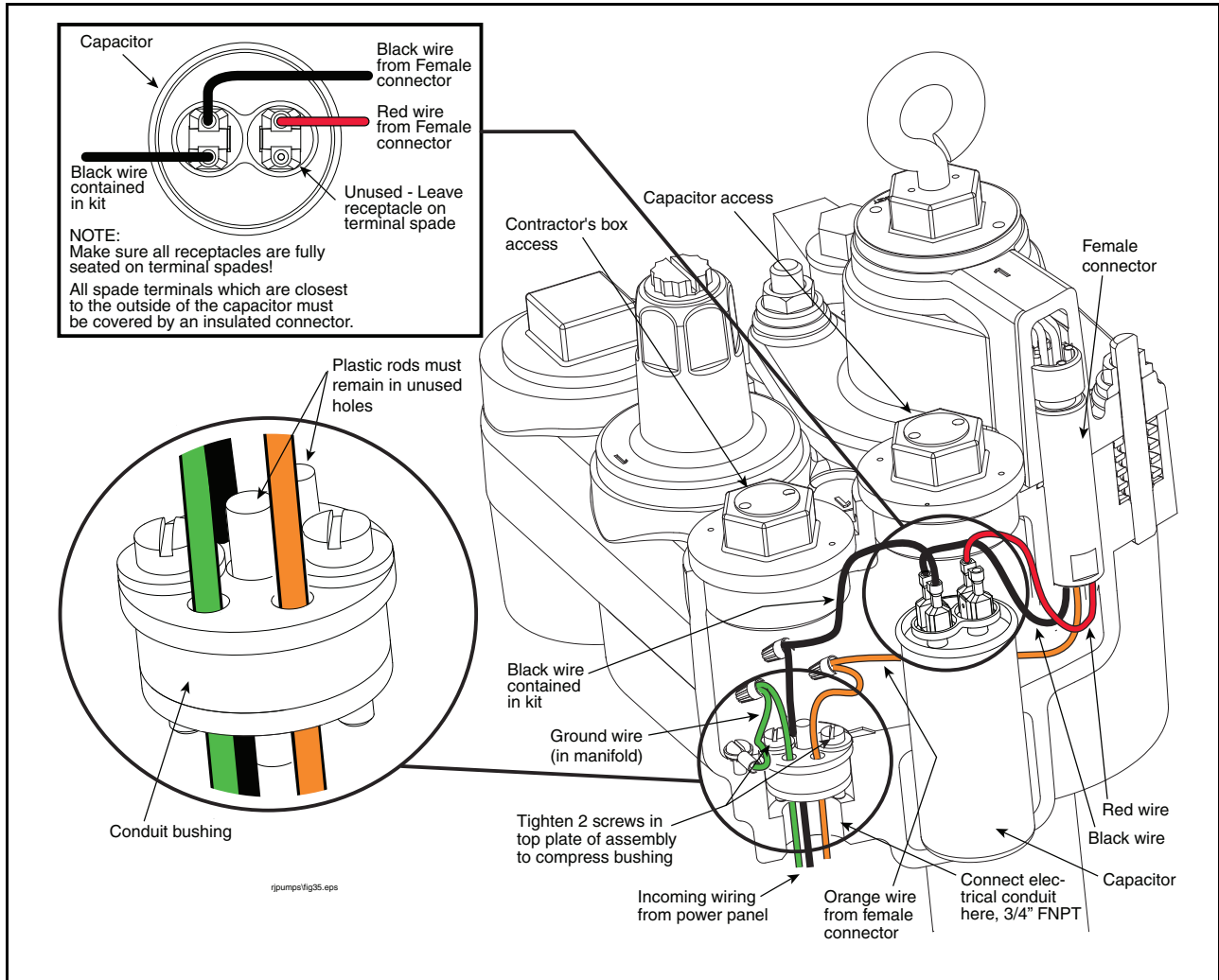

Figure 17. Power Wiring Enters Through Compression Bushing - Single Phase Example Shown

For Single Phase Pumps with Capacitor

See Figure 18 for Steps 1 - 4.

1. Connect the orange wire from manifold's female connector to M1 from the power panel.
2. Connect the terminal end of the short black wire (in the kit) to one of the terminals on the same post of the capacitor as the black wire from the manifold's female connector. Connection must be made to the terminal which is closest to the OUTSIDE of the capacitor. Connect the open end of this black wire to M2 from the output of the control box.
3. Connect the ground wire from power panel to the attached ground wire in manifold.
4. Replace the o-rings on the access covers. Lubricate the o-rings with petroleum based jelly. Reinstall the access covers. Torque to 35 ft-lbs (50 N•m). Thread sealant should NOT be used.

NOTICE For all models with the 'RA' suffix, place the supplied plastic protector on the access covers prior to torquing (see Figure 15). By not using the protectors, damage may occur to the powder coating, causing corrosion.

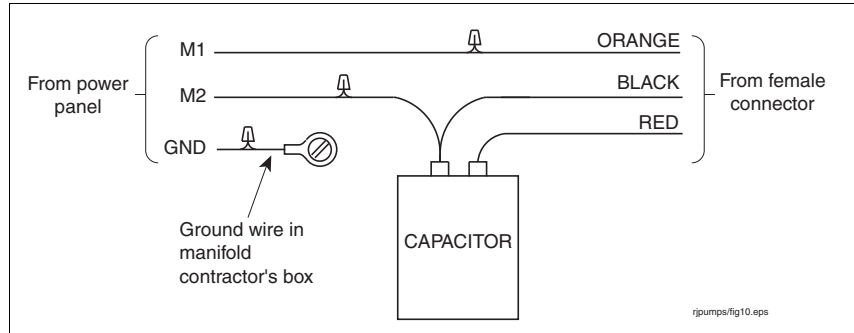

Figure 18. Power Wiring Schematic For Single Phase Pumps

Refer to Figure 19 through Figure 26 for various single phase pump system example wiring diagrams.

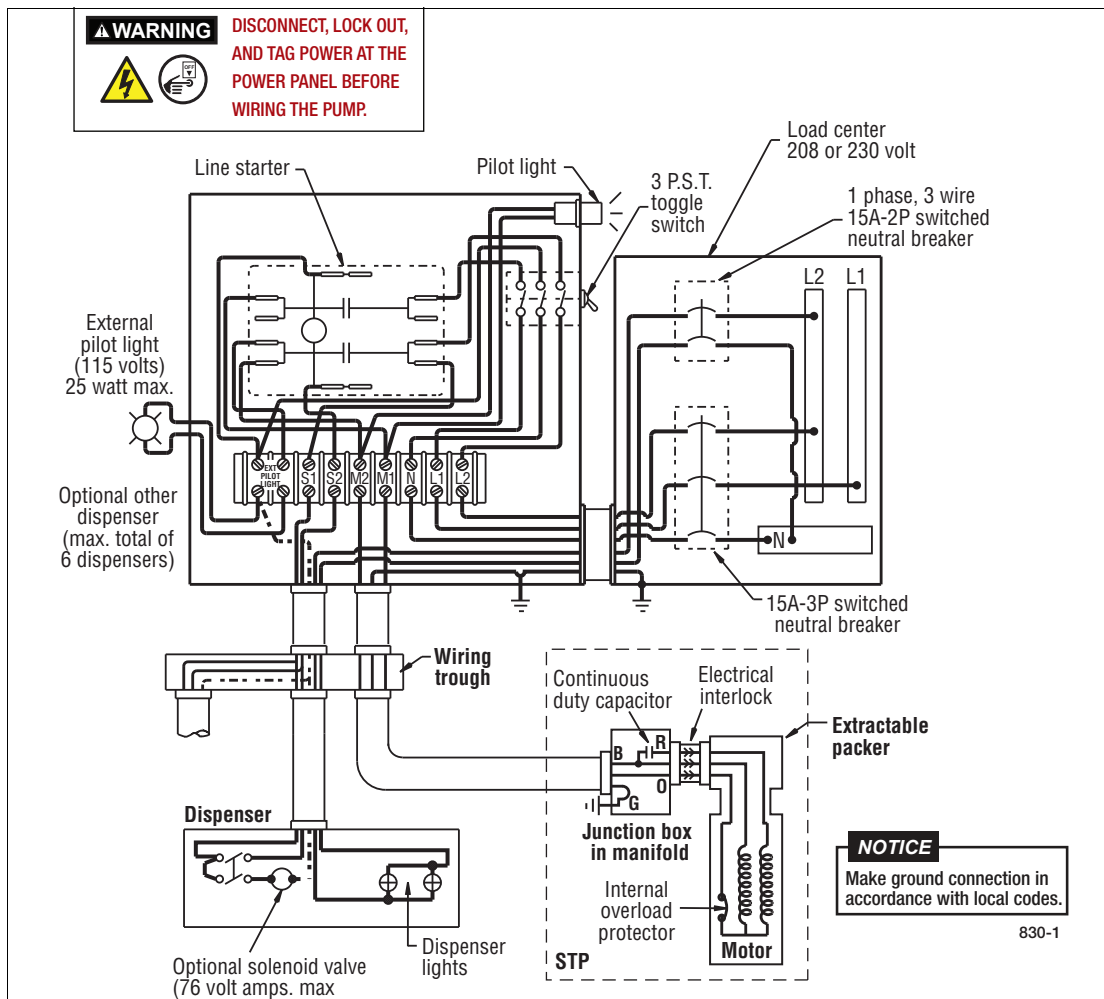

Figure 19. 230 Vac Remote Control Box With 110 Vac Coil - Model 880-041-5

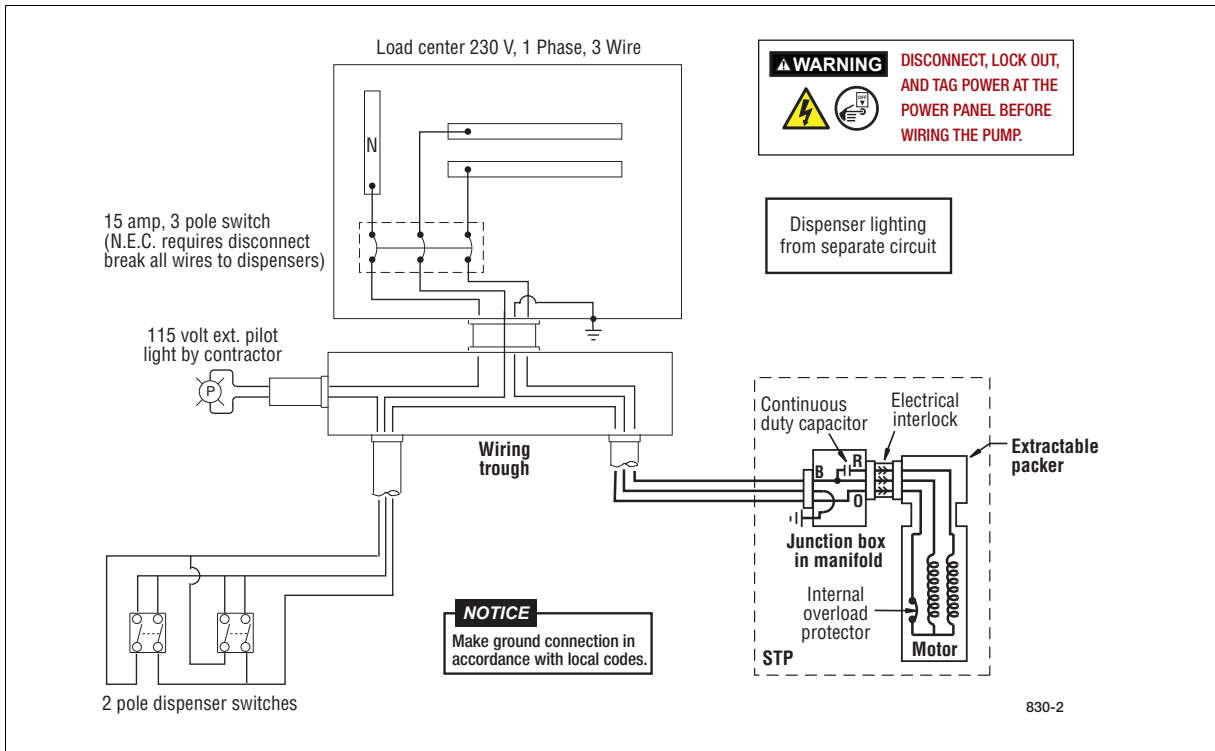

Figure 20. Suggested Wiring Diagram Without Optional Control Box

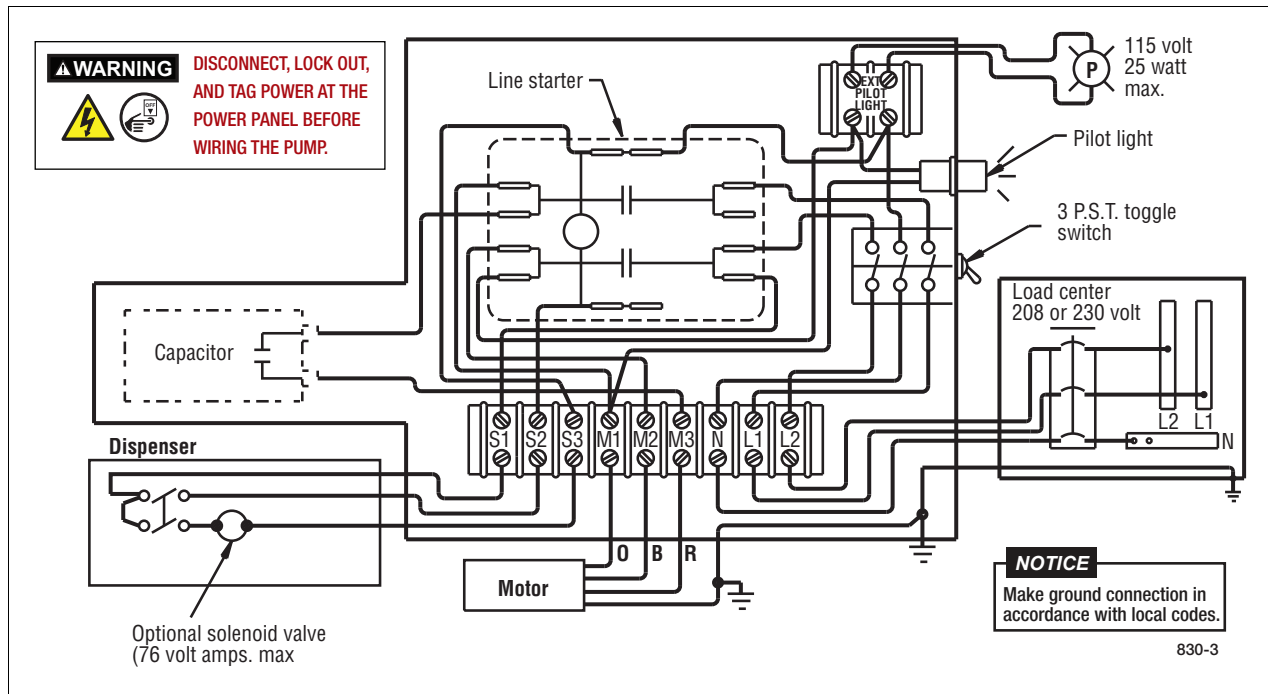

Figure 21. 230 Vac Remote Control Box With 110 Vac Coil And Cap - Model 880-045-5/880-046-5

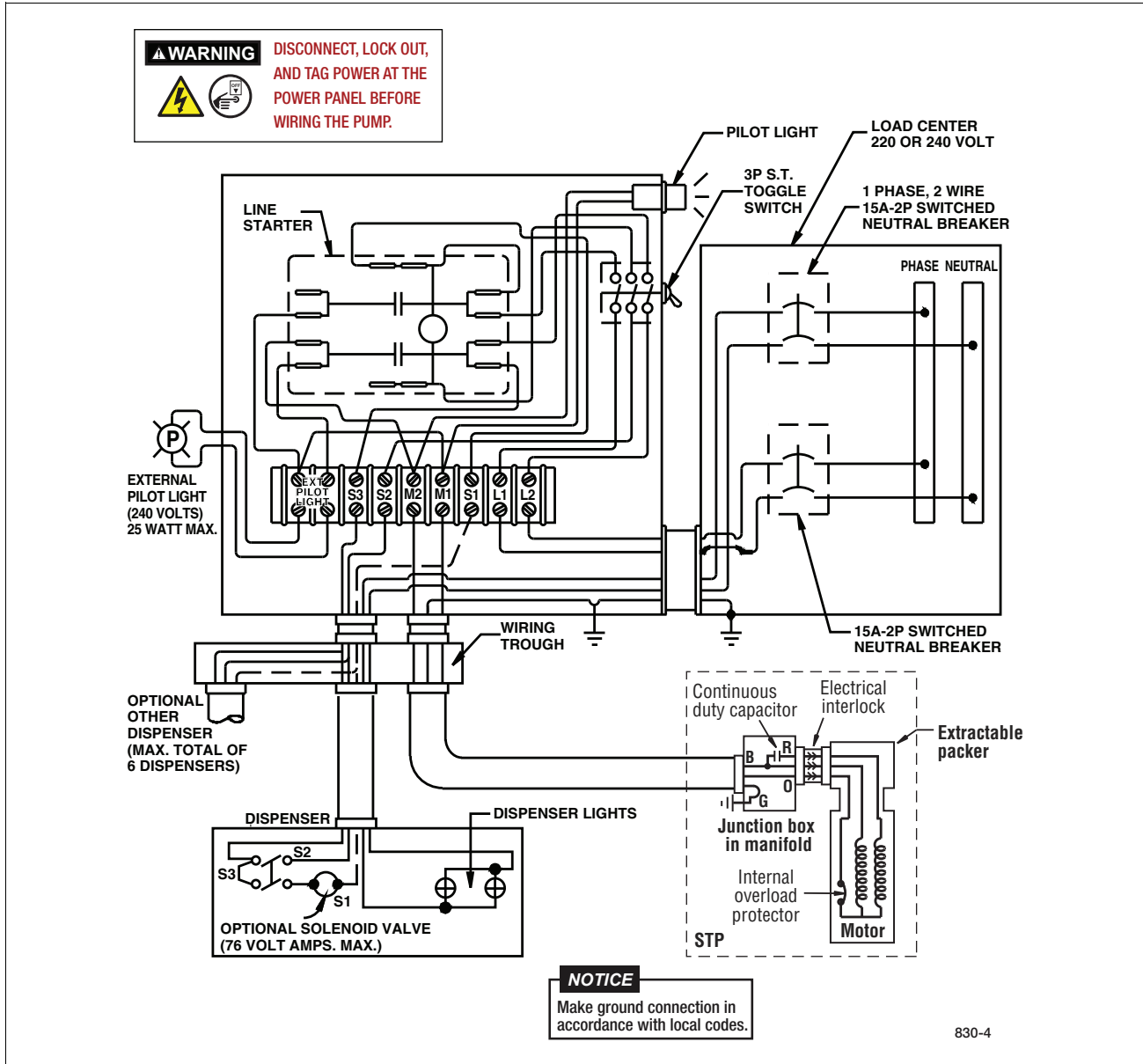

Figure 22. 230 Vac Remote Control Box With 230 Vac Coil - Model 880-042-5

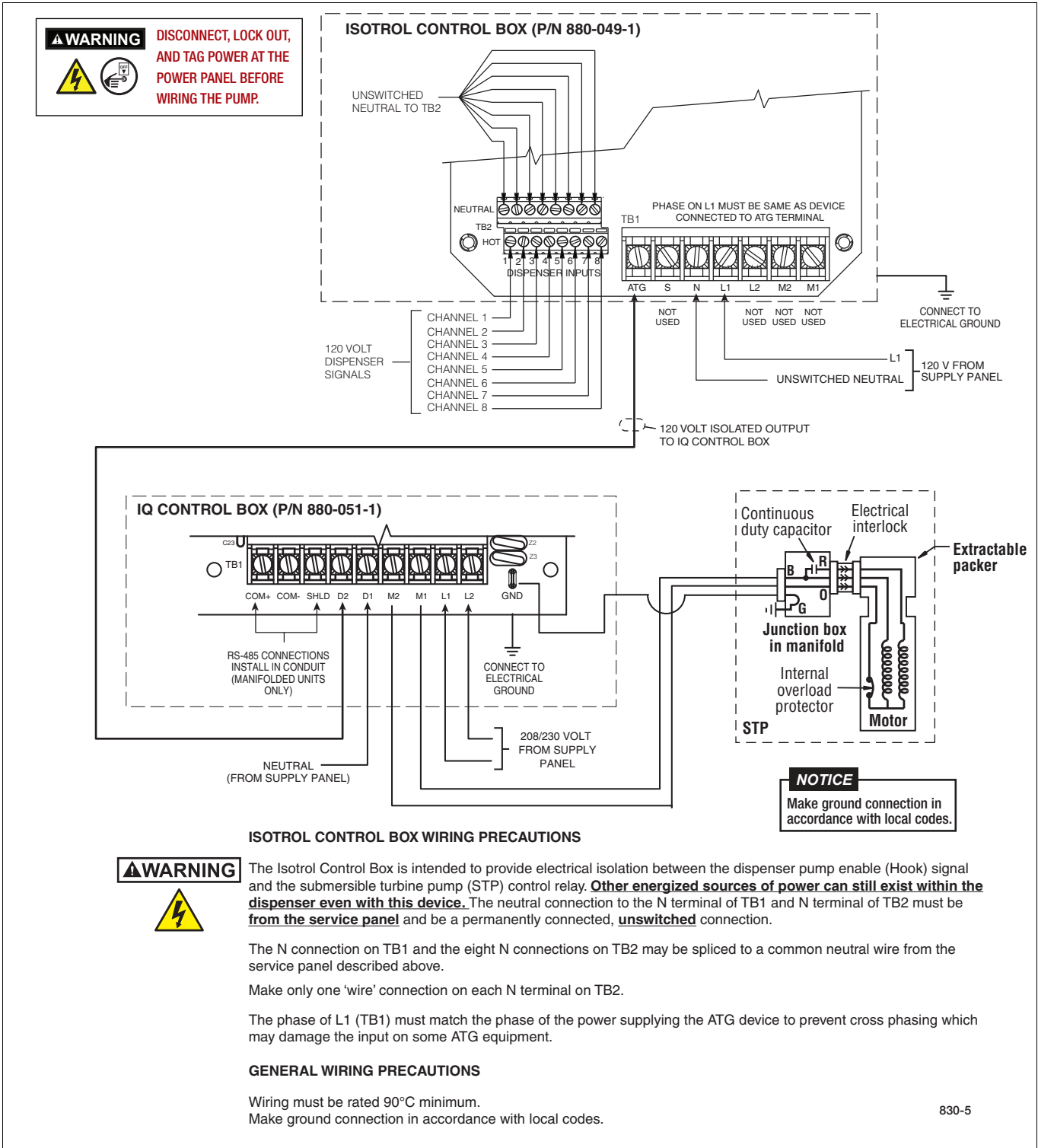

Figure 23. Isotrol To IQ System Wiring - 120 Volt Dispenser Signals

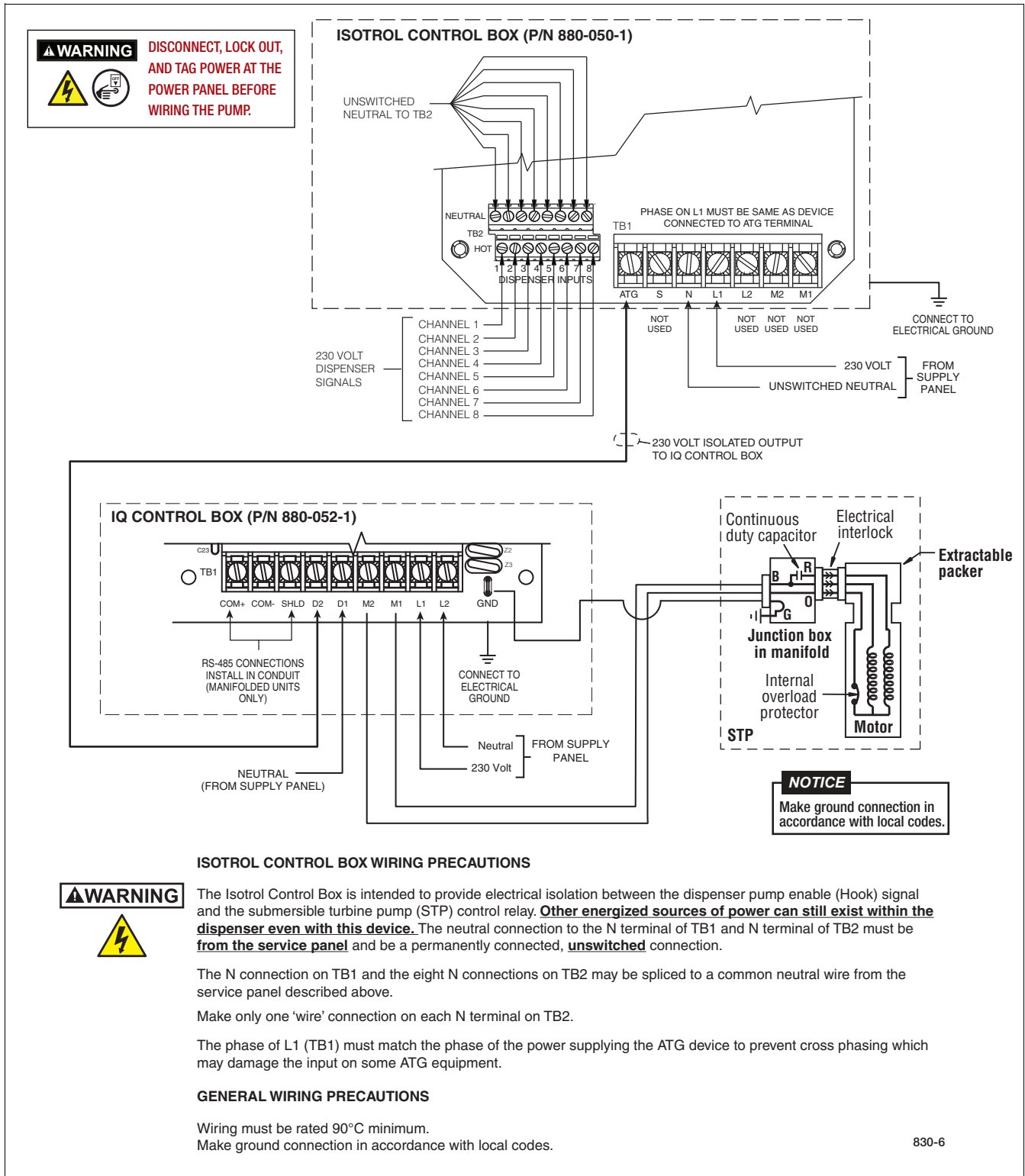

Figure 24. Isotrol To IQ System Wiring - 230 Volt Dispenser Signals

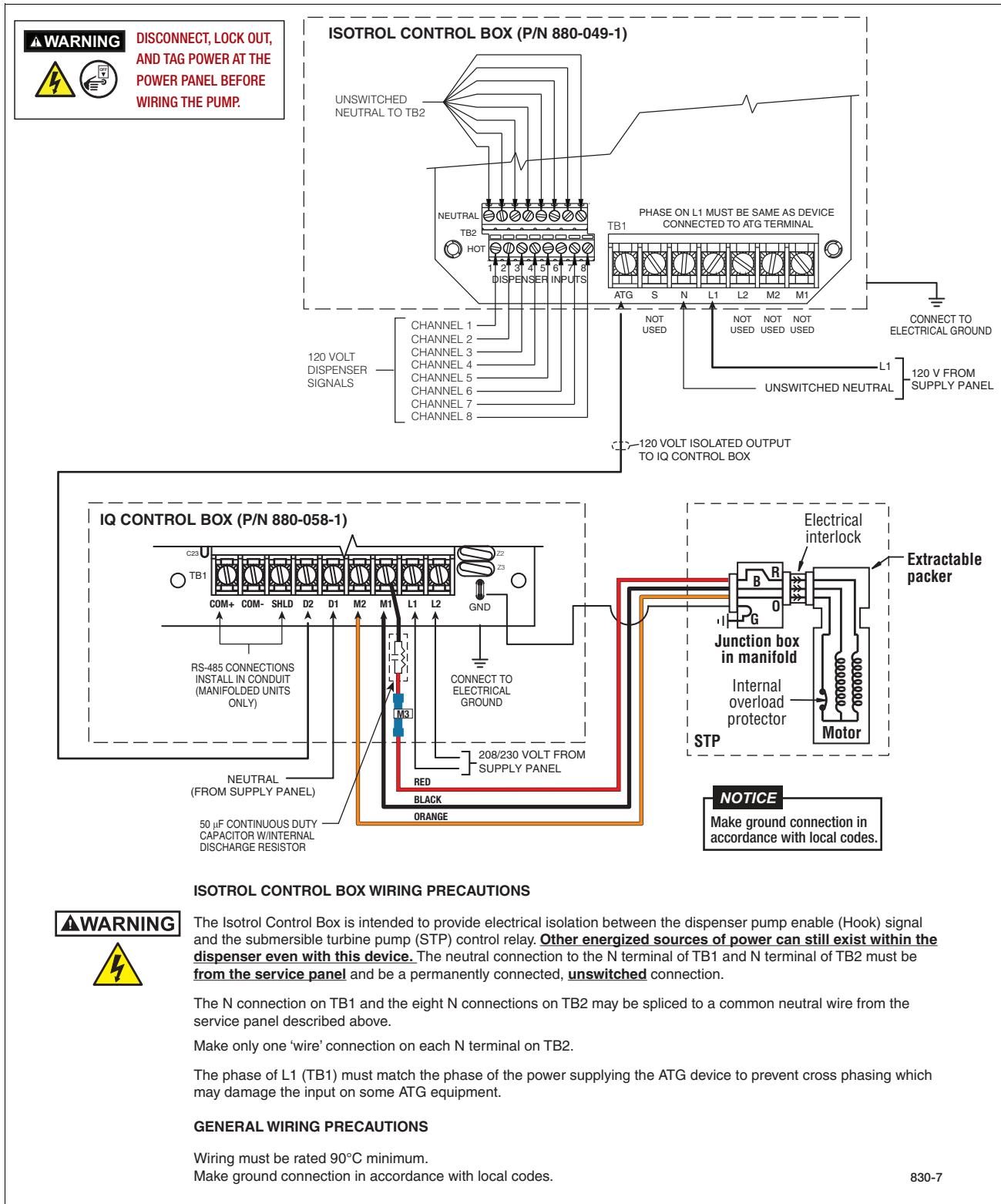
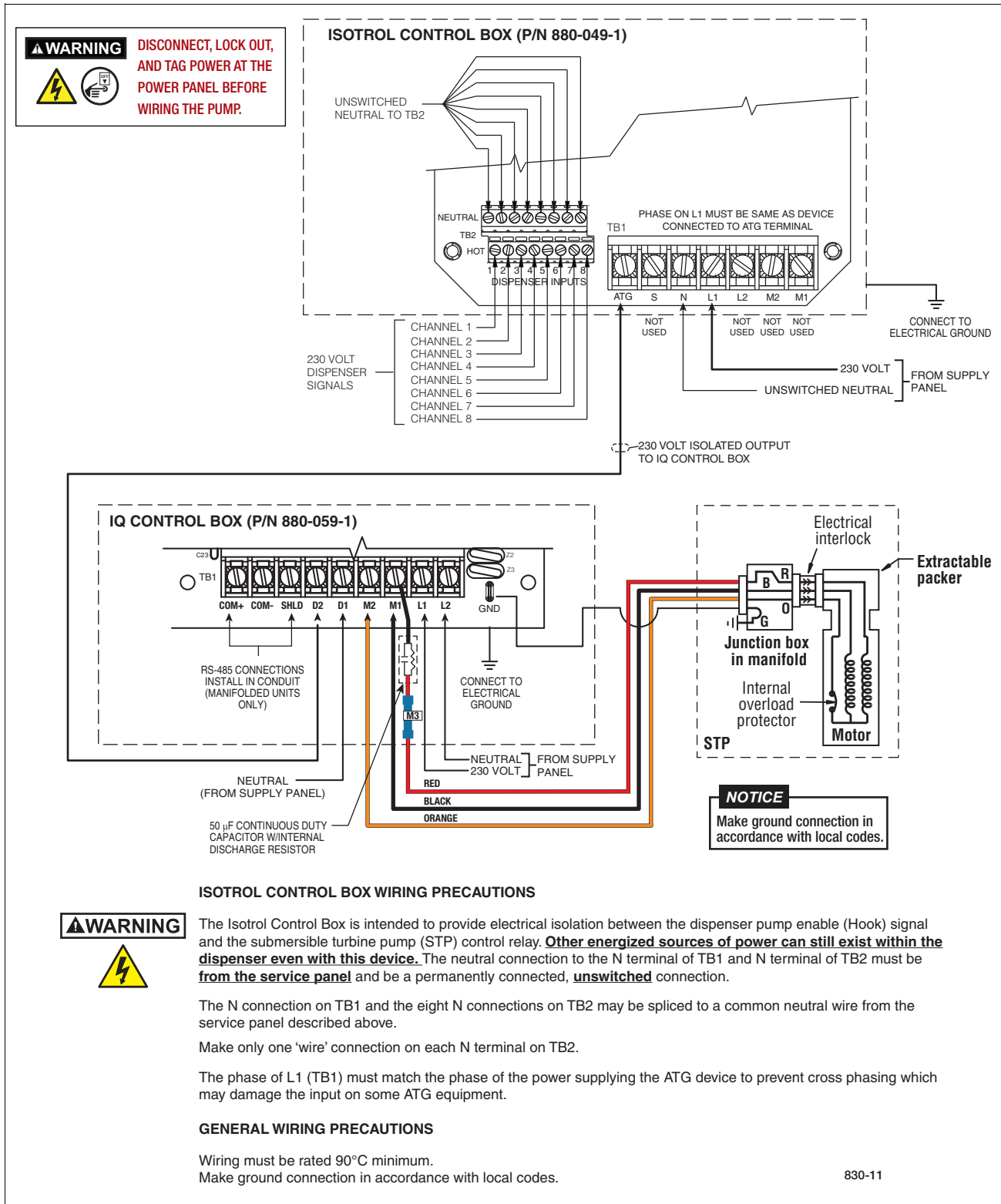

Figure 25. Isotrol To IQ W/2HP Capacitor - System Wiring - 120 Volt Dispenser Signals



For Three Phase Pumps (without Capacitor)

See Figure 27 for Steps 1 - 5.

1. Connect the orange wire from the manifold's female connector to M1 from the output of the control box.
2. Connect the black wire from the manifold's female connector to M2 from the output of the control box.
3. Connect the red wire from the manifold's female connector to M3 from the output of the control box.
4. Connect the attached ground wire in the manifold to the ground wire from the power panel.
5. Replace the o-rings on access covers. Lubricate the o-rings with petroleum based jelly. Reinstall the access covers. Torque to 35 ft-lbs (50 N•m). Thread sealant should NOT be used.

NOTICE For all models with the 'RA' suffix, place the supplied plastic protector on the access covers prior to torquing (see Figure 15). By not using the protectors, damage may occur to the powder coating, causing corrosion.

Refer to Figure 28 for example three phase pump system wiring diagrams.

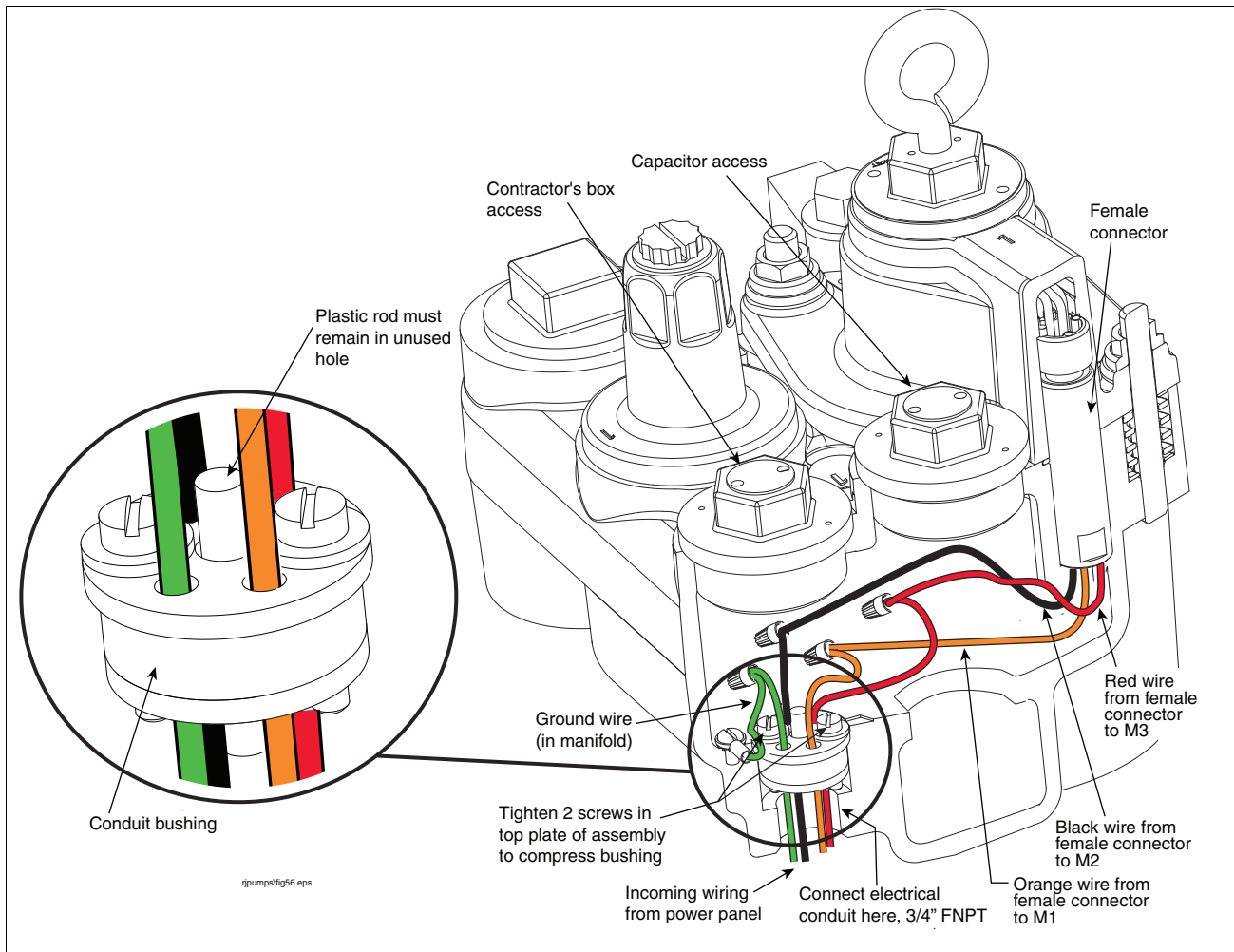

Figure 27. Power Wiring Enters Through Compression Bushing - Three Phase Example Shown

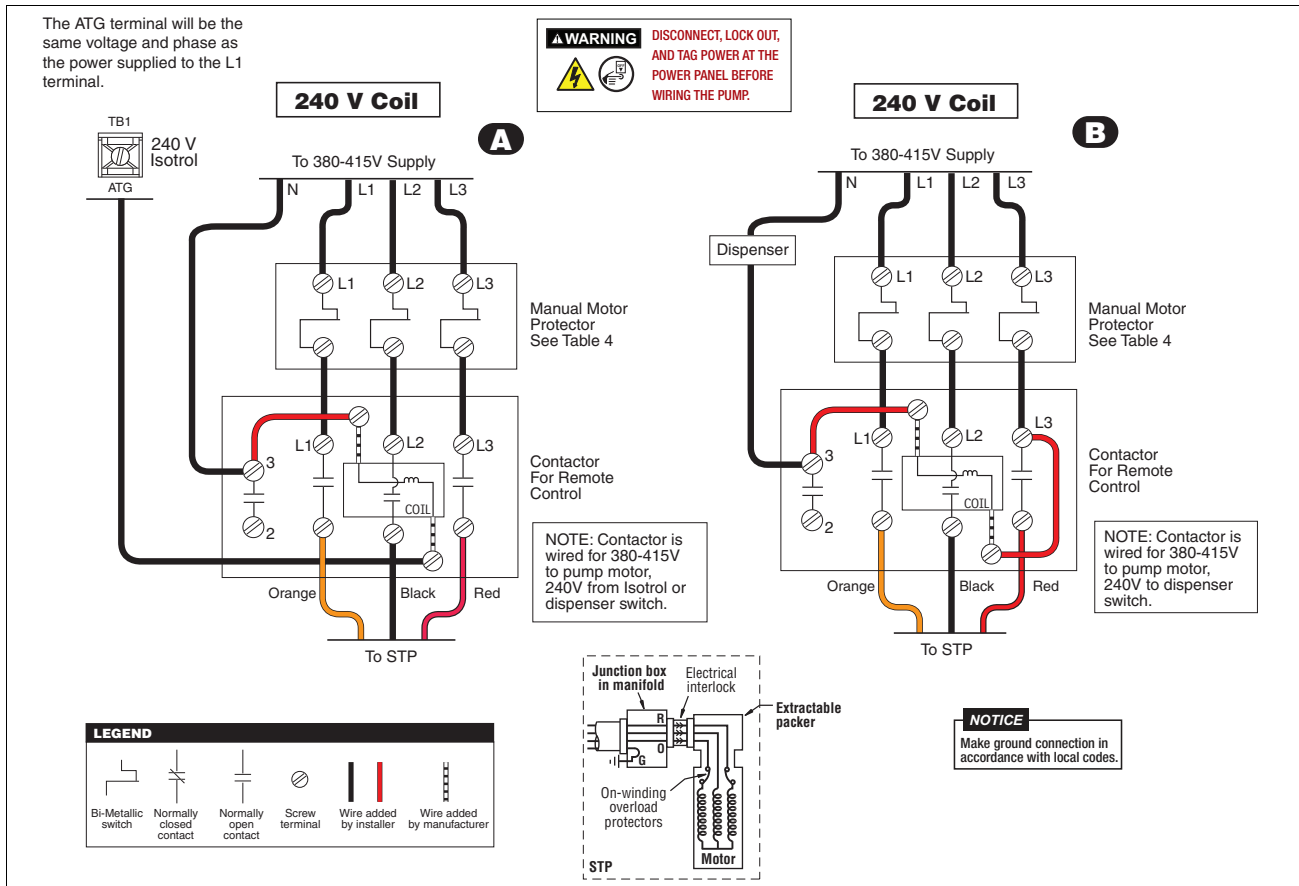

Figure 28. Three Phase Pump Wiring Diagram Examples

Connecting to the External Equipotential Bonding Terminal

A M6 threaded fastener set is provided on the side of the manifold identified by the symbol for equipotential bonding. Refer to Figure 29 for the location underneath the double siphon port facility. If required by nationally applicable installation regulations or by conditions per certificate (see Appendix C or Appendix E), connection to this terminal is to be made using a conductor having a cross-sectional area of at least 4mm² (10 AWG).

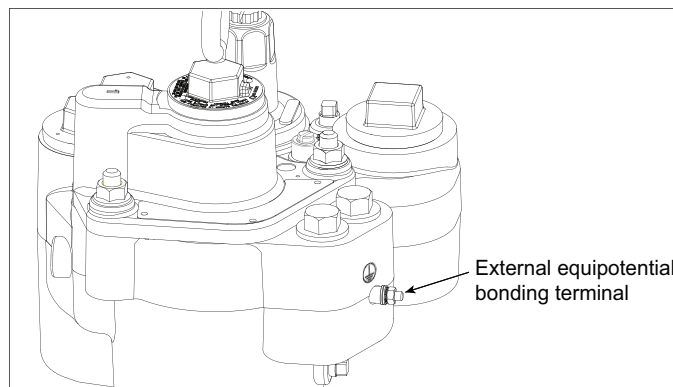

Figure 29. Equipotential Bonding Terminal

Installing Two Pumps for Tandem Operation

When greater flow rates are needed, two pumps may be installed in the same piping system by means of a manifold. If installed according to the Figure 30, tandem systems offer backup support so operations can continue if one pump stops working.

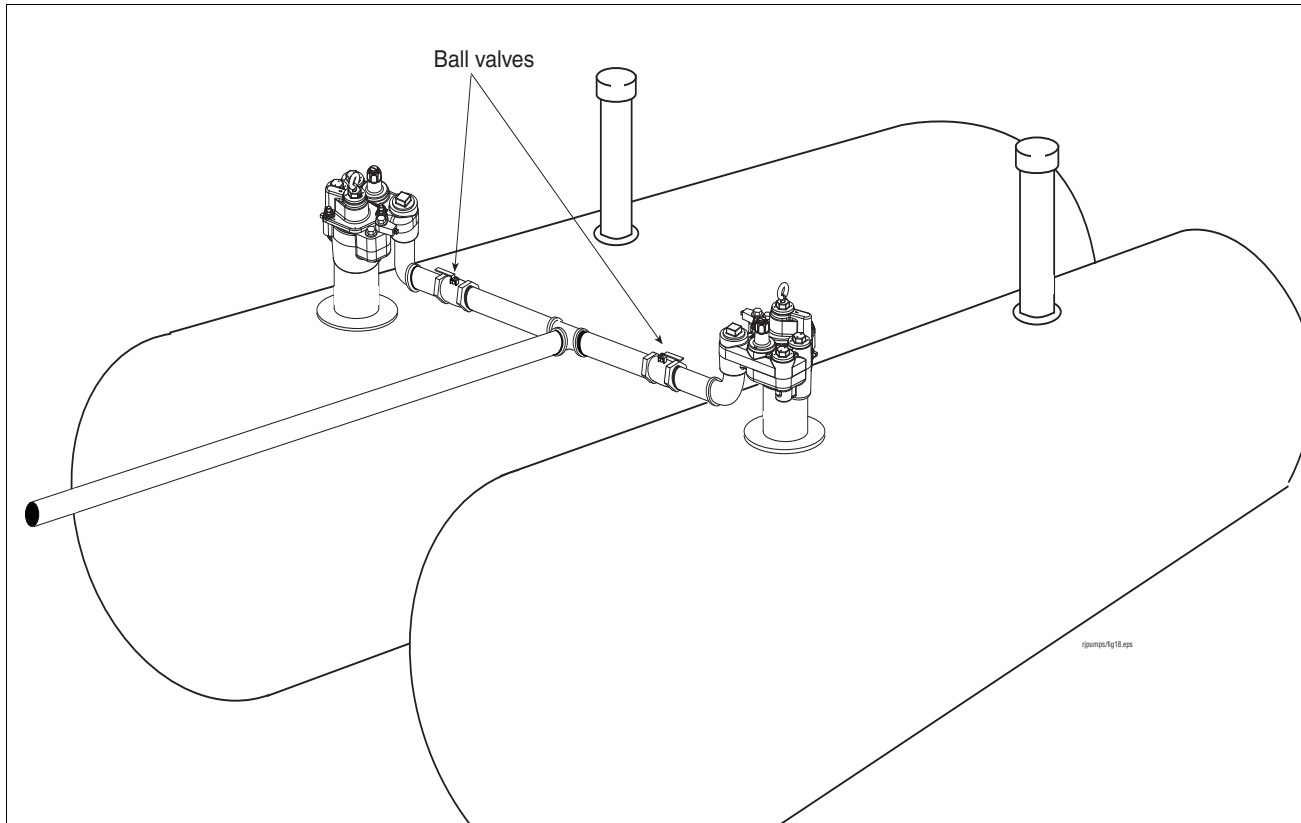

Figure 30. Tandem Pumps

⚠ WARNING Proper check valves with pressure relief are required to be installed in the discharge line of each pump to prevent product from being pumped through the pressure relief system of the adjacent pump when it is not operating.

NOTICE Ball valves should be installed at the pump end of the discharge line for ease of maintenance and troubleshooting (see Figure 30).

Wiring Single Phase Tandem Pumps

Figure 31 shows the wiring allowing both single phase STPs to operate simultaneously with any combination of dispensers turned on. To operate individually, the appropriate toggle switch, located externally on the side of the control box, can be turned off manually.

Alternatively, Veeder-Root's Red Jacket IQ™ Control Unit can be connected to additional control boxes to allow up to four pumps per tank with demand-based sequencing. UMPs containing a Faradyne motor require IQ software 805-001 C (Version 3.2 or newer for proper operation of the system. Refer to specification section.

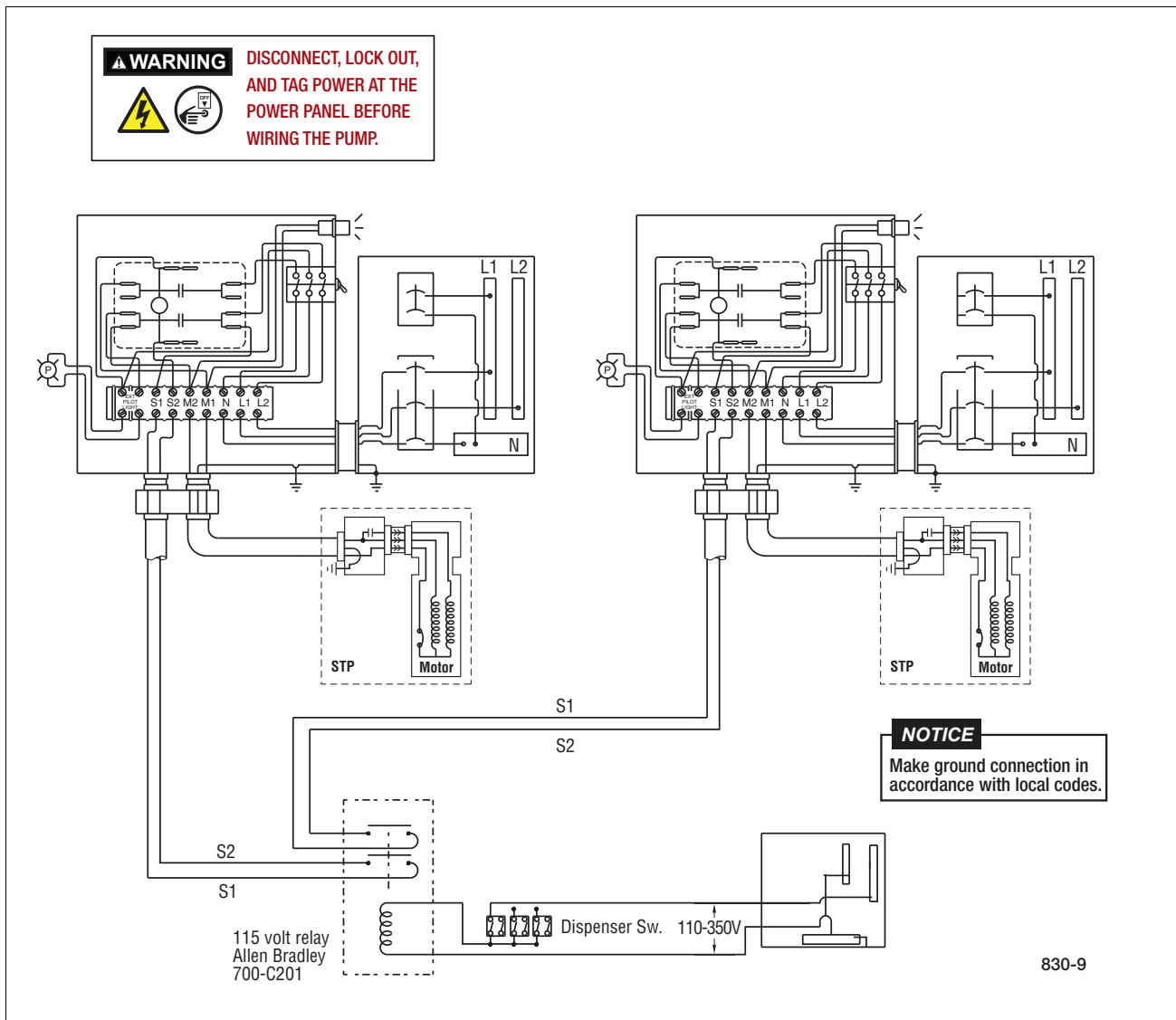

Figure 31. Suggested Wiring For Single Phase Tandem Pumps

Wiring Three Phase Tandem Pumps

Figure 32 shows the wiring schematic which allows both three phase STPs to operate simultaneously with any combination of dispensers turned on.

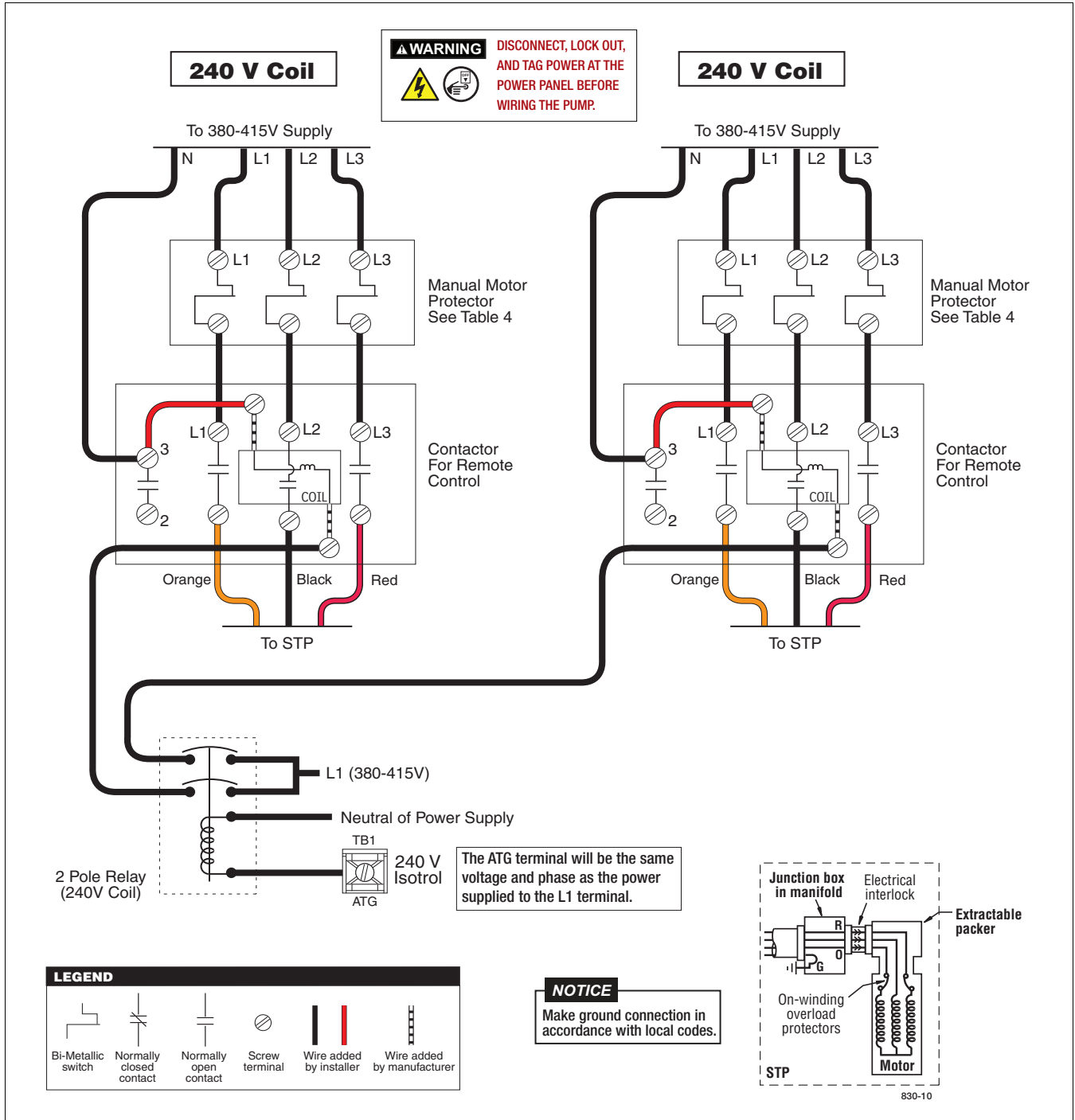

Figure 32. Suggested Wiring For Three Phase Tandem Pumps

Siphon Ports

The siphon port for The Red Jacket STP is in a siphon assembly that fits into one of the two vacuum ports (see Figure 33). The port end can be swiveled after loosening the hex on top to accommodate the incoming siphon tube. Torque the siphon assembly to 15-30 ft-lbs (20-41 N•m) after positioning.

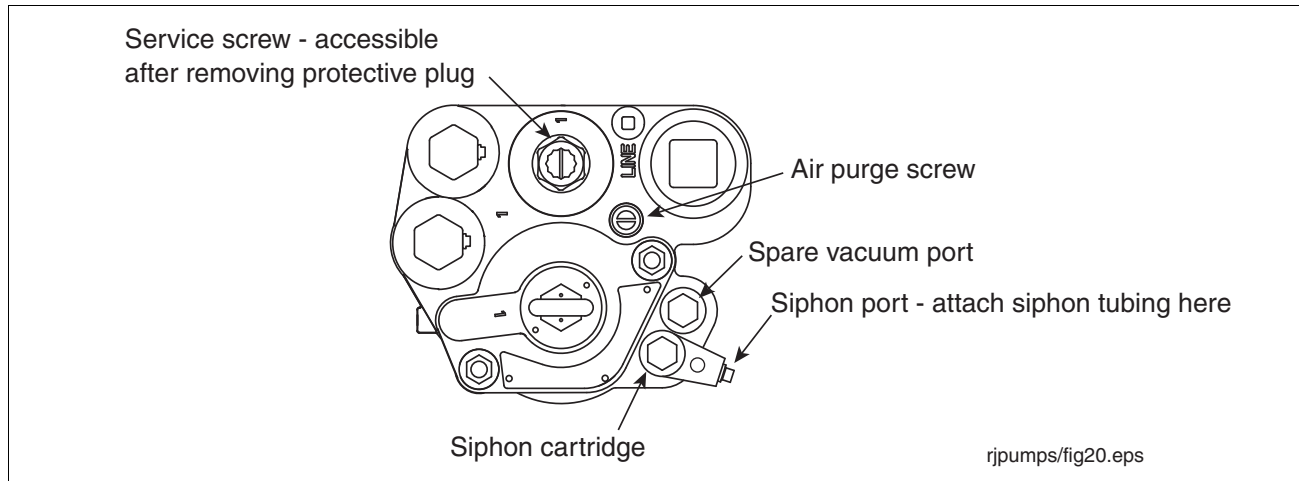

Figure 33. Siphon Connection

NOTICE The 1/4" NPT plug in the siphon assembly should be removed and the siphon line attached.

⚠ WARNING Before installing pipe threads, apply an adequate amount of fresh, UL classified for petroleum, non-setting thread sealant. For AG applications, Loctite 564 is recommended for all field serviceable pipe threads. Apply sealant in a manner that prevents it from entering and contaminating hydraulic cavities.

Installing a Siphon Assembly

▲WARNING



Disconnect, lock out, and tag power at the panel before servicing the pump.



When servicing equipment, use non-sparking tools and use caution when removing or installing equipment to avoid generating a spark.

Kits Required:

- Siphon Cartridge Kit (P/N 410151-001)
- AG Siphon Cartridge Kit (P/N 410151-002)

Procedure:

1. If a ball valve is installed down line from the pump, close it.
2. Remove and save the protective plug over the service screw and turn the screw clockwise (see Figure 34). As the screw approaches its bottom position, you will hear the system depressurizing. Continue turning the screw until it can go no further. When the screw is all the way down, backoff the screw 4 turns to lift the check valve and let the fuel drain out of the manifold's hydraulic cavities.
3. Remove one of the two siphon port plugs from the manifold (see Figure 34).

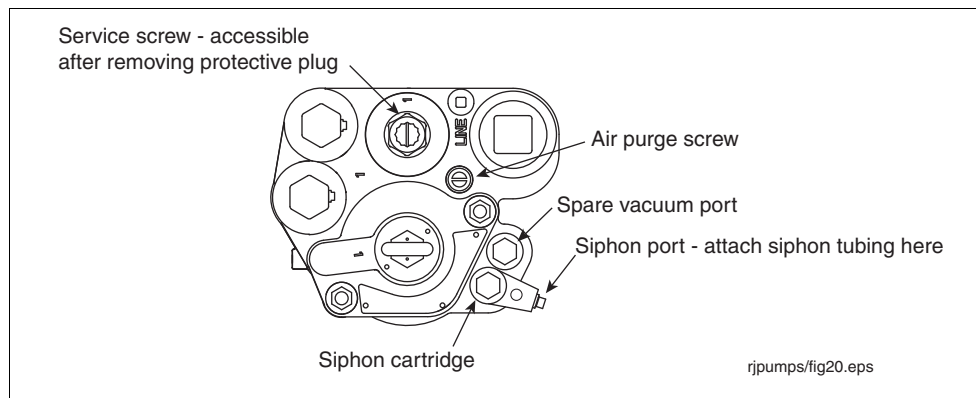

Figure 34. Siphon Ports

4. Get the siphon cartridge from the kit and apply a coating of petroleum jelly onto the three o-rings on the outside of the siphon cartridge.
5. Insert the siphon cartridge into the siphon port (see Figure 35). Swivel the outlet port of the siphon in the desired direction, and then hand tighten the siphon's retaining hex body. Torque the body to 25 - 30 ft-lbs (34 - 41 N•m).
6. Remove the 1/4" NPT plug from the siphon outlet port and attach siphon system tubing.

▲WARNING

Before installing pipe threads, apply an adequate amount of fresh, UL classified for petroleum, non-setting thread sealant. For AG applications, Loctite 564 is recommended for all field serviceable pipe threads. Apply sealant in a manner that prevents it from entering and contaminating hydraulic cavities.

7. Turn the service screw counterclockwise all the way up. As the screw approaches its top position, the check valve will drop into position.

8. Replace the protective plug over the service screw and fully thread into place to ensure a good seal.
9. Turn the air purge screw 2 - 3 turns counterclockwise (see Figure 34).

⚠WARNING The air purge screw is retained by a hitch pin to limit travel. Do not attempt to rotate beyond 3 turns.

10. Turn the pump on and let it run for about 2 minutes to purge air from the manifold's hydraulic cavities. While the pump is still running, turn the air purge screw clockwise until it is completely closed.
11. If applicable, open the ball valve down line from the pump.

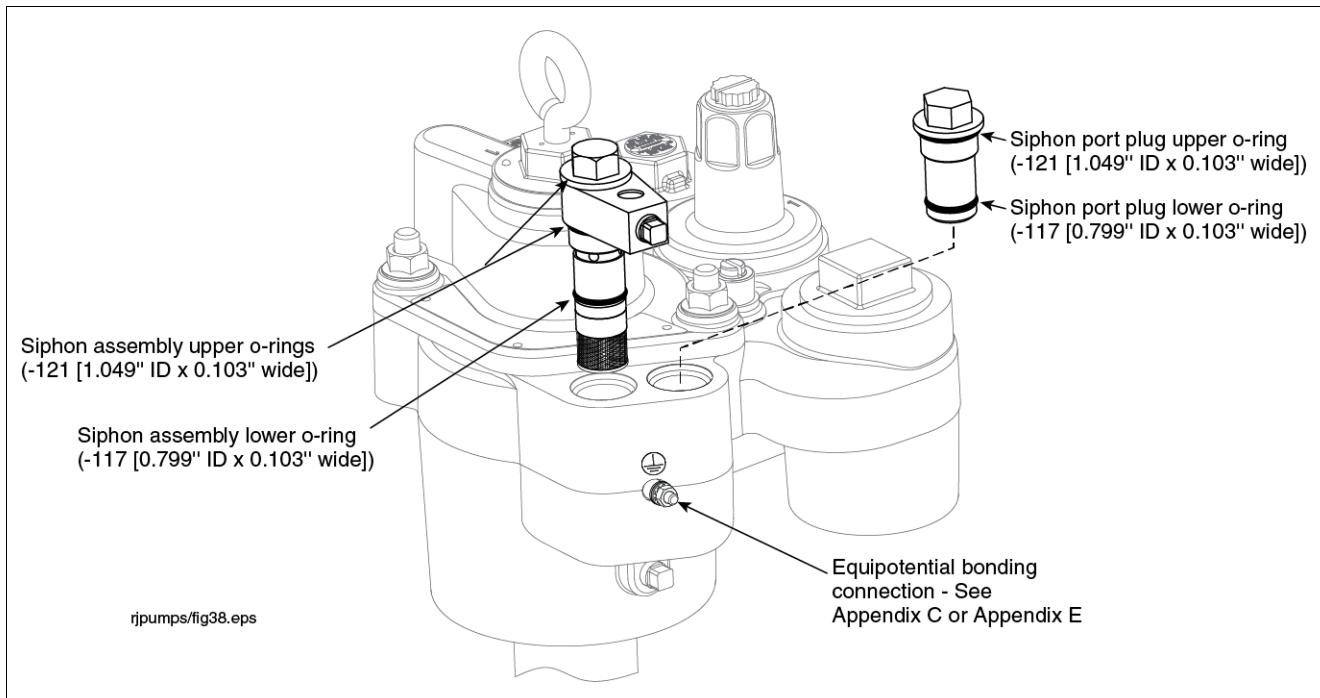

Figure 35. Inserting Siphon Assembly Into Manifold

Installing an Electronic Line Leak Detector Transducer or Mechanical LLD

WARNING



Disconnect, lock out, and tag power at the panel before servicing the pump.



When servicing equipment, use non-sparking tools and use caution when removing or installing equipment to avoid generating a spark.

Kits Required:

- Hardware/Seal Kit (AG) (P/N 410154-001)

Other Parts:

- Electronic or mechanical line leak detector

Procedure:

1. If a ball valve is installed down line from the pump, close it.
2. Remove and save the protective plug over the service screw and turn the screw clockwise (see Figure 36). As the screw approaches its bottom position, you will hear the system depressurizing. Continue turning the screw until it can go no further. When the screw is all the way down, backoff the screw 4 turns to lift the check valve and let the fuel drain out of the manifold's hydraulic cavities.
3. Remove the 2" NPT plug from line leak detector port.

NOTICE For all models with the 'RA' suffix, place the supplied plastic protector on the 2" NPT plug prior to torquing (see Figure 15). By not using the protectors, damage may occur to the powder coating, causing corrosion.

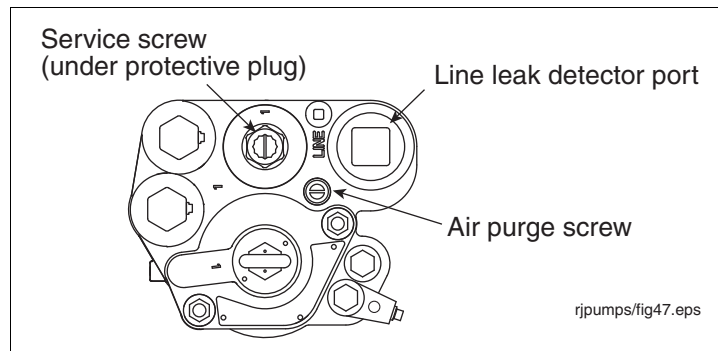

Figure 36. Locating Discharge Port Plug For Line Leak Transducer

4. Install leak detector into the 2" NPT port as per instructions included with device.
5. Turn the service screw counterclockwise all the way up. As the screw nears its top position you will hear the check valve drop into position. Replace the protective plug over the service screw and fully thread into place to ensure a good seal.
6. Open the air purge screw 2 - 3 turns counterclockwise (see Figure 36).

⚠ WARNING The air purge screw is retained by a hitch pin to limit travel. Do not attempt to rotate beyond 3 turns.

7. Turn the pump on and let it run for about 2 minutes to purge air from the manifold's hydraulic cavities. While the pump is still running, turn the air purge screw clockwise until it is completely closed.
8. If applicable, open the ball valve down line from the pump.

Initial Start Up of Pump

1. If a ball valve is installed down line from the pump, close it.
2. Open the air purge screw 2 - 3 turns counterclockwise (see Figure 33).

⚠ WARNING The air purge screw is retained by a hitch pin to limit travel. Do not attempt to rotate beyond 3 turns.

3. Turn the pump on and let it run for about 2 minutes to purge air from the manifold's hydraulic cavities. While the pump is still running, turn the air purge screw clockwise until it is completely closed.
4. If applicable, open the ball valve down line from the pump.
5. Turn on the pump and purge system of air by pumping at least 15 gallons (57 liters) through each dispenser. Begin with the dispenser furthest from the pump and work back toward the pump.
6. Pump start up is now complete.

NOTE: For Three Phase Pumps Only!

Where it is not convenient to predetermine the power supply phase rotation, proper rotation can be determined by pump performance. Pump head pressure and capacity will be considerably less than rated when rotating backwards.

Connect the pump leads to terminal T1, T2, and T3 of the magnetic starter observing color code shown in Figure 28 A, B, and C. With ample product in the tank and the system purged of air, start the pump and make a pressure gauge reading of the system pressure with the ball valve closed; or, open valve and calculate pumping rate.

Next, reverse power leads at L1 and L2. Repeat either pressure or capacity tests, as described above. If results are higher than the first test, the rotation of the second test is correct. If the second test gives lower performance than the first, reconnect the power leads to L1 and L2 (as under test 1) for correct rotation.

Where the power supply has been properly marked L1, L2, and L3 in accordance with accepted phase rotation standards, it is possible to predetermine the proper rotation of these units. The pump power leads are color coded orange, black, and red, and if connected through the magnetic starter to L1, L2, and L3 respectively, the UMP will rotate in the correct direction. It is recommended, however, that the performance tests always be made whether or not the power supply has been properly 'phased out'.

Pump Tests

Verifying Relief Pressure

The relief pressure is factory set to 19 to 25 psi (131 - 172 kPa).

There are two methods used to verify the relief pressure setting;

- The pressure reading can be taken from the control unit of an electronic line leak detection system if one is in operation. Observe the pressure that occurs after the pump turns off - this is the relief pressure.
- Pressure may be observed using a gauge attached at the impact valve or to the pump's line test port (see Figure 37).

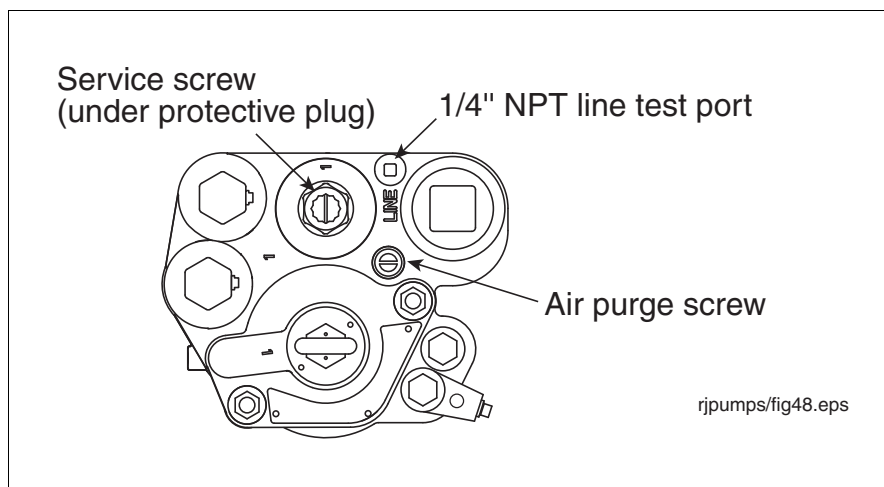

Figure 37. Locating Pump Line Test Port

Checking Relief Pressure at the Pump

WARNING



Disconnect, lock out, and tag power at the panel before starting to service the pump.



When servicing equipment, use non-sparking tools and use caution when removing or installing equipment to avoid generating a spark.

Equipment required:

- Pressure gauge with appropriate fittings to connect to the 1/4" NPT line test port

Procedure:

1. If a ball valve is installed down line from the pump, close it.
2. Remove and save the protective plug over the service screw and turn the screw clockwise (see Figure 37). As the screw approaches its bottom position, you will hear the system depressurizing. Continue turning the screw until it can go no further. When the screw is all the way down, backoff the screw 4 turns to lift the check valve and let the fuel drain out of the manifold's hydraulic cavities. Continue to turn the screw all the way counterclockwise. When the screw is almost up, the check valve will drop down into position.

3. Remove the line test port plug (see Figure 37) and attach test gauge.
4. Open the air purge screw 2 - 3 turns counterclockwise (see Figure 37).

▲WARNING The air purge screw is retained by a hitch pin to limit travel. Do not attempt to rotate beyond 3 turns.

5. Turn the pump on and let it run for about 2 minutes to purge air from the manifold's hydraulic cavities. While the pump is still running, turn the air purge screw clockwise until it is completely closed.
6. Turn off the pump and measure the relief pressure.
7. Turn the service screw clockwise. As the screw approaches its bottom position, you will hear the system depressurizing. Continue turning the screw until it can go no further. When the screw is all the way down, backoff the screw 4 turns to lift the check valve and let the fuel drain out of the manifold's hydraulic cavities.
8. Turn the service screw counterclockwise all the way up. As the screw nears its top position you will hear the check valve drop into position. Replace the protective plug over the service screw and fully thread into place to ensure a good seal.
9. Remove the test gauge. Apply an adequate amount of fresh, UL classified for petroleum, non-setting thread sealant on the 1/4" NPT plug and replace it in the line test port. Torque the plug to 14 to 21 ft-lbs (19.4 to 29 N•m). For AG applications, Loctite 564 is recommended for all field serviceable pipe threads.
10. Turn the air purge screw 2 - 3 turns counterclockwise.

▲WARNING The air purge screw is retained by a hitch pin to limit travel. Do not attempt to rotate beyond 3 turns.

11. Turn the pump on and let it run for about 2 minutes to purge air from the manifold's hydraulic cavities. While the pump is still running, turn the air purge screw clockwise until it is completely closed.
12. The pump is now ready for normal operation.
13. If applicable, open ball valve down line from the pump.

Testing the Line

▲WARNING



Disconnect, lock out, and tag power at the panel before starting to service the pump.



When servicing equipment, use non-sparking tools and use caution when removing or installing equipment to avoid generating a spark.

Equipment required:

- Pressure generating equipment with appropriate fittings to connect to the 1/4" NPT line test port

Procedure

1. Block lines at each dispenser.
2. Remove and retain the protective plug over the service screw and turn the screw clockwise (see Figure 37). As the screw approaches its bottom position, you will hear the system depressurizing. Continue turning the screw until it can go no further.
3. Remove line test port plug (see Figure 38). Apply line test pressure at line test port (50 psi [345 kPa] maximum).

▲WARNING

Excessive pressure (above the normal test pressure of 50 - 55 psi [345 - 380 kPa]) may damage check valve seat and other system components.

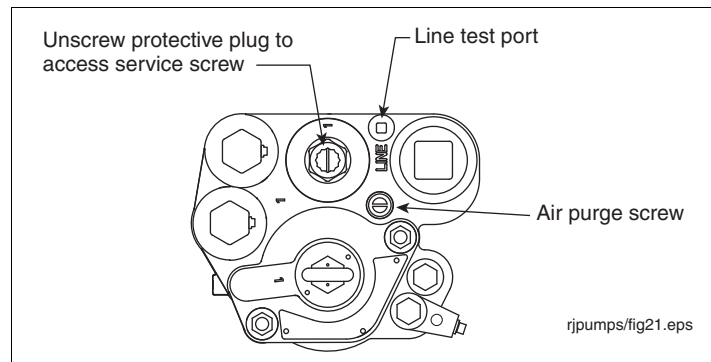

Figure 38. Service Screw, Line Test Port And Air Purge Screw Locations

4. Depressurize the line (as per Step 2 above) and remove test fixture. Apply an adequate amount of fresh, UL classified for petroleum, non-setting thread sealant on the 1/4" NPT plug and replace it in the line test port. Torque the plug to 14 to 21 ft-lbs (19.4 to 29 N•m). For AG applications, Loctite 564 is recommended for all field serviceable pipe threads.
5. Turn the service screw counterclockwise all the way up. As the screw nears its top position you will hear the check valve drop into position. Replace the protective plug over the service screw and fully thread into place to ensure a good seal.
6. Turn the air purge screw 2 - 3 turns counterclockwise (see Figure 38).

▲WARNING

The air purge screw is retained by a hitch pin to limit travel. Do not attempt to rotate beyond 3 turns.

7. Turn the pump on and let it run for about 2 minutes to purge air from the manifold's hydraulic cavities. While the pump is still running, turn the air purge screw clockwise until it is completely closed.
8. The pump is now ready for normal operation.
9. If applicable, unblock lines at each dispenser.

Testing the tank

▲WARNING



WARNING! Disconnect, lock out, and tag power at the panel before starting to service the pump.



When servicing equipment, use non-sparking tools and use caution when removing or installing equipment to avoid generating a spark.

Equipment required:

- Pressure generating equipment with appropriate fittings to connect to the 1/4" NPT tank test port

Procedure:

1. Remove and retain the protective plug over service screw and turn the screw clockwise (see Figure 38). As the screw approaches its bottom position, you will hear the system depressurizing. Continue turning the screw until it can go no further.
2. Remove and save the 1/4 " NPT tank test port plug and attach tank testing equipment (see Figure 39).

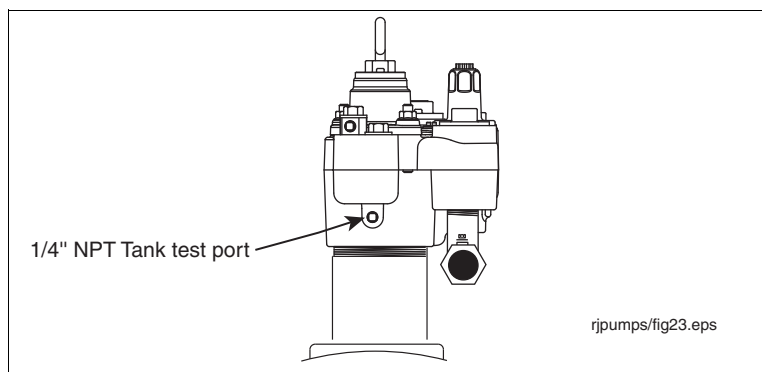

Figure 39. Tank Test Port On Manifold

3. Depressurize tank and remove testing equipment. Apply an adequate amount of fresh, UL classified for petroleum, non-setting thread sealant on the 1/4" NPT plug and replace it in the tank test port. Torque the plug to 14 to 21 ft-lbs (19.4 to 29 N•m). For AG applications, Loctite 564 is recommended for all field serviceable pipe threads.
4. Turn the service screw counterclockwise all the way up. As the screw nears its top position you will hear the check valve drop into position. Replace the protective plug over the service screw and fully thread into place to ensure a good seal.
5. Turn the air purge screw 2 - 3 turns counterclockwise (see Figure 38).

▲WARNING

The air purge screw is retained by a hitch pin to limit travel. Do not attempt to rotate beyond 3 turns.

6. Turn the pump on and let it run for about 2 minutes to purge air from the manifold's hydraulic cavities. While the pump is still running, turn the air purge screw clockwise until it is completely closed.
7. The pump is now ready for normal operation.

Service And Repair

Replacing the UMP

WARNING



Disconnect, lock out, and tag power at the panel before starting to service the pump.



When servicing equipment, use non-sparking tools and use caution when removing or installing equipment to avoid generating a spark.

Kits Required:

- UMP Replacement Kit, P/N 144-327-4 (P/N 410818-001 for AG Applications)
- Hardware/Seal Kit (AG) (P/N 410154-001)
- Die Spring Kit, P/N 410485-001 (P/N 410906-001 for RA models)

Procedure:

1. If a ball valve is installed down line from the pump, close it.
2. Remove the two extractable lock-down nuts (see Figure 39). The springs on the lock-down studs between the extractable's flange and the manifold will push the extractable up, breaking the seals.

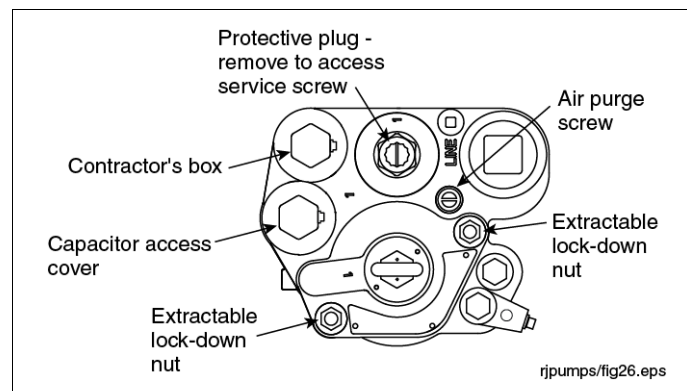

Figure 39. Extractable Lock-Down Nuts

WARNING

Confirm that the lifting eyebolt is properly torqued to 10 ft-lbs (13.6 N•m) with a minimum of 6 full threads installed. Occasionally, eyebolts are removed after pump installation and corrosion may occur in the threaded areas of the wiring compartment cover (eyebolt plug) and the eyebolt. If corrosion has occurred, the cover and eyebolt should be replaced.

3. Utilize the lifting eyebolt to lift out the extractable unit and place it on a clean surface. **Removal of the extractable section of the pump must be conducted with caution.** Make certain that the extractable section remains centered within the riser pipe and that no portion of the extractable binds during the removal process. If binding occurs during removal, stop and determine the cause of the binding and correct the situation before proceeding with removal.

NOTICE

For all models with the 'RA' suffix, take care not to damage the powder coating on the packer/manifold and discharge head when placing the pump on the working surface.

4. Remove the old UMP by removing the four bolts holding the discharge head as shown in Figure 40. Discard the old gasket and fasteners.

- Place the new gasket from the UMP replacement kit on the new UMP so that all the holes align.

CAUTION Gaskets from competitive UMPs will not seal properly and performance will be reduced.

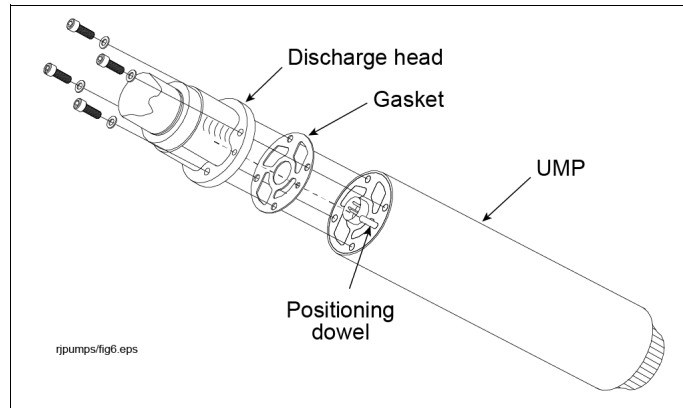

Figure 40. UMP Bolts And Gasket

- Pull the pigtail connector in the discharge head out far enough to see the o-ring in the sidewall of its socket (see Figure 41). Remove the connector's o-ring from the connector's socket and discard it. Get a 0.551" ID x 0.070" wide o-ring from the kit and lubricate it with petroleum jelly. Slide the new o-ring over the pigtail connector and push it in the groove in the wall of the connector's socket. Lubricate the pigtail connector body with petroleum jelly and push it back into its socket, making sure its index tab is in the socket's notch.

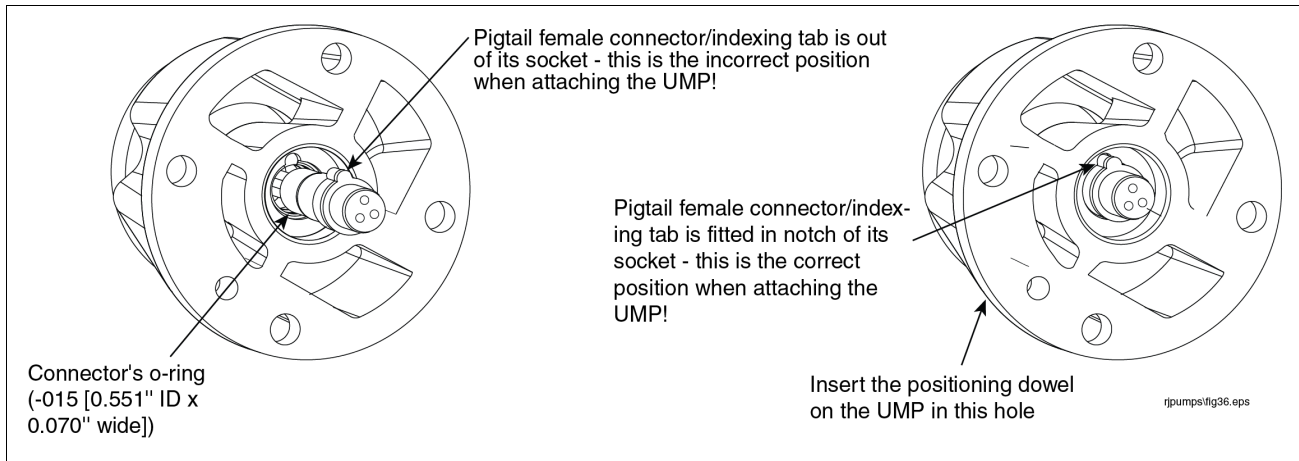

Figure 41. Verifying Pigtail's Female Connector Is Seated Properly

- Align the UMP positioning dowel so it inserts in the proper hole in the discharge head (see Figure 41) and push the UMP into position using hand force only. The UMP should be snug against the discharge head prior to installing the UMP retaining bolts.

WARNING Use hand force to push the UMP onto the discharge head. If the UMP does not seat snug against the discharge head, remove the UMP and correct the problem.

- Install the four UMP retaining bolts and lock washers. Snug and then torque the bolts using a cross pattern technique to 7 ft-lbs (11 N•m).

⚠ WARNING Do not use the bolts to pull the UMP into position. Use the cross pattern to snug and torque the bolts. Do not over torque the bolts. Not following these instructions may cause parts to fail.

9. Get the three extractable o-ring seals (3.975" ID x 0.210" wide [upper], 3.850" ID x 0.210" wide [middle], and 3.725" x 0.210" wide [lower]) from the hardware/seal kit. The three o-rings are very close in size so take extra care to distinguish each one before replacing them in the extractable. Lubricate each o-ring with petroleum jelly and then install them in their assigned grooves in the extractable (see Figure 42).
10. Remove the manifold's female connector's o-ring (see Figure 42). Get a 0.862" ID x 0.103" wide o-ring from the kit and lubricate it with petroleum jelly. Slide the o-ring over the female connector and push it down into its groove.
11. Reinstall the extractable unit into the manifold and tank. Torque the extractable lock-down nuts in an alternating pattern to 50 ft-lbs (68 N•m).

NOTICE Remove the springs around the lock-down studs and replace with the springs from the kit.

For all models with the 'RA' suffix, stainless steel lock-down nuts and washers are used and found in the kit. Apply anti-seize (also found in the kit) to the lock-down studs prior to nut and washer installation.

12. Turn the air purge screw 2 - 3 turns counterclockwise (see Figure 39).

⚠ WARNING The air purge screw is retained by a hitch pin to limit travel. Do not attempt to rotate beyond 3 turns.

13. Turn the pump on and let it run for about 2 minutes to purge air from the manifold's hydraulic cavities. While the pump is still running, turn the air purge screw clockwise until it is completely closed.
14. If applicable, open the ball valve down line from the pump.

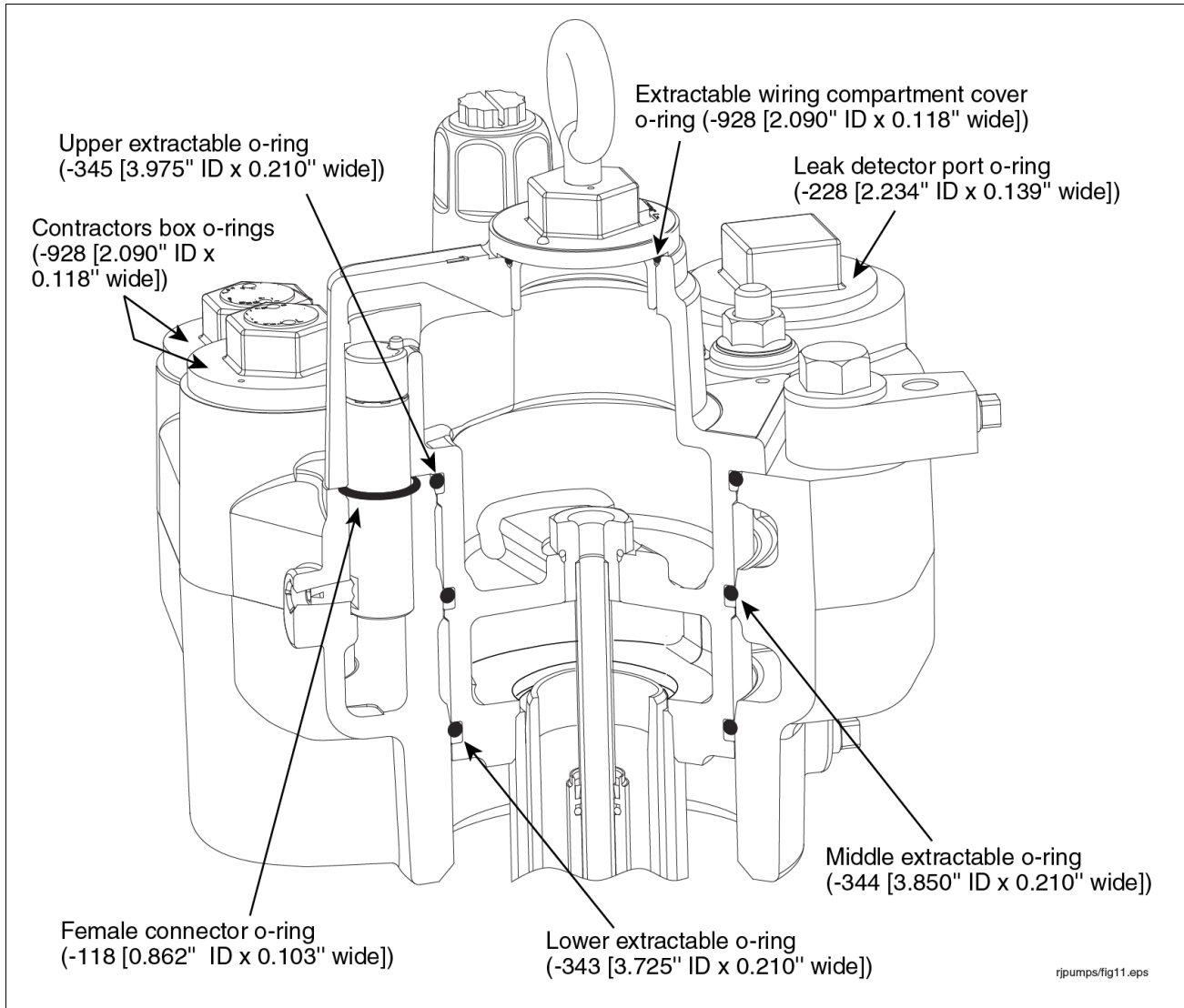

Figure 42. Locating Packer And Manifold O-Rings

Replacing the Capacitor in the Manifold for Single Phase Pumps

WARNING



Disconnect, lock out, and tag power at the panel before starting to service the pump.



When servicing equipment, use non-sparking tools and use caution when removing or installing equipment to avoid generating a spark.

WARNING

Serious injury or death can result from using a generic-type capacitor. Generic-type capacitors do not contain internal bleed resistors.

The capacitor is 440V, 17.5 μF continuous duty with internal bleed resistor for 1/3 and 3/4 HP models. The capacitor is 440V, 25 μF continuous duty with internal bleed resistor for 1-1/2 HP models. The capacitor is 440V, 40 μF continuous duty with internal bleed resistor for 2 HP models.

Kits Required:

- Capacitor Kit (P/N 410164-001 [17.5 μF], 410164-002 [25 μF], or 410164-003 [40 μF] as required).
- Hardware/Seal Kit (AG) (P/N 410154-001)

Procedure:

1. Remove capacitor access cover (see Figure 43).

NOTICE For all models with the 'RA' suffix, place the supplied plastic protector on the access cover prior to torquing (see Figure 15). By not using the protector, damage may occur to the powder coating, causing corrosion.

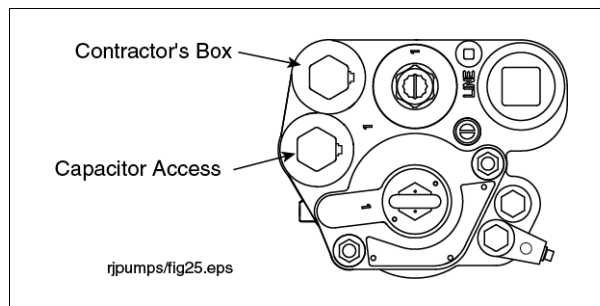

Figure 43. Locating Contractor's Box And Capacitor Compartment

2. Examine current wiring attached to existing capacitor as the wiring will attach in an identical manner to the replacement capacitor.
3. Remove wires from the old capacitor and remove the old capacitor from the manifold compartment.
4. Insert new capacitor into the manifold compartment and attach the wire terminals exactly as they were connected to the old capacitor (see Figure 18 on page 23).
5. Replace the o-ring (2.090" ID x 0.118" wide) in the capacitor access cover after lubricating the o-ring with petroleum jelly. Reinstall the cover. Do not use thread sealant. Torque the cover to 35 ft-lbs (50 N•m).

NOTICE For all models with the 'RA' suffix, place the supplied plastic protector on the access cover prior to torquing (see Figure 15). By not using the protector, damage may occur to the powder coating, causing corrosion.

Replacing the Check Valve Assembly

WARNING



Disconnect, lock out, and tag power at the panel before starting to service the pump.



When servicing equipment, use non-sparking tools and use caution when removing or installing equipment to avoid generating a spark.

Kits Required:

- Check Valve Housing Kit (P/N 410152-001 [P/N 410152-005 for RA' models]) or
- Check Valve Kit (P/N 410153-001) and Hardware/Seal Kit (AG) (P/N 410154-001)

Procedure:

1. If a ball valve is installed down line from the pump, close it.
2. Remove and save the protective plug over the service screw and turn the screw clockwise (see below).

Service screw - accessible
after removing protective plug

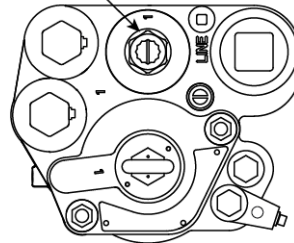

As the screw approaches its bottom position, you will hear the system depressurizing. Continue turning the screw until it can go no further. When the screw is all the way down, backoff the screw 4 turns to lift the check valve and let the fuel drain out of the manifold's hydraulic cavities. Continue to turn the screw counterclockwise until you hear the check valve drop down into position.

3. Unscrew the check valve housing. Lift the spring and check valve out of the manifold. Discard the o-ring from the housing and from the check valve.

NOTICE If replacing the check valve o-ring, avoid twisting or rotating the o-ring as it is being installed on the check valve.

For all models with the 'RA' suffix, place the supplied plastic protector on the check valve housing prior to torquing (see Figure 15). By not using the protector, damage may occur to the powder coating, causing corrosion.

4. Get the new check valve and spring from the kit. If you have the Check valve housing kit, get the new housing and o-ring (2.609" ID x 0.139" wide) from the kit, if you only have the check valve kit, get a new 2.609" ID x 0.139" wide housing o-ring from the hardware/seal kit.
5. Lubricate the new housing o-ring and the new 1.859" ID x 0.139" wide o-ring on the check valve with petroleum jelly.
6. With its lubricated o-ring in place, insert the check valve onto its seat in the manifold, and place the new spring over the check valve (see Figure 44). Place the check valve housing with o-ring over the spring and check valve and screw it in hand tight. Torque the housing to 40 - 50 ft-lbs (54 - 67 N•m).

NOTICE For all models with the 'RA' suffix, place the supplied plastic protector on the check valve housing prior to torquing (see Figure 15). By not using the protector, damage may occur to the powder coating, causing corrosion.

7. Replace the protective plug over the service screw and fully thread into place to ensure a good seal.
8. Open the air purge screw 2 - 3 turns counterclockwise (see Figure 44).

WARNING The air purge screw is retained by a hitch pin to limit travel. Do not attempt to rotate beyond 3 turns.

9. Turn the pump on and let it run for about 2 minutes to purge air from the manifold's hydraulic cavities. While the pump is still running, turn the air purge screw clockwise until it is completely closed.
10. If applicable, open the ball valve down line from the pump.

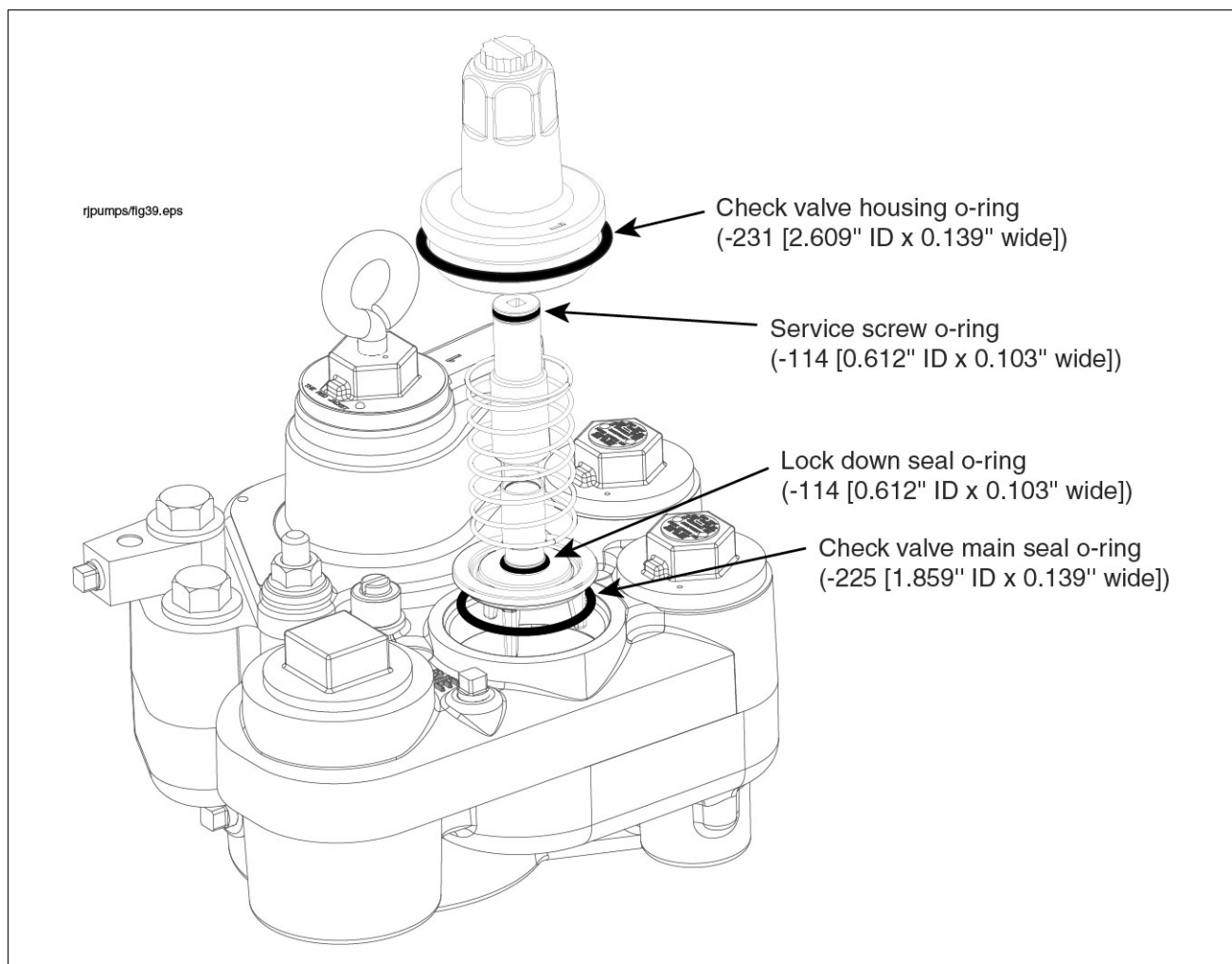

Figure 44. Inserting Check Valve Assembly Into Manifold

Replacing the Conduit Bushing

WARNING



Disconnect, lock out, and tag power at the panel before starting to service the pump.



When servicing equipment, use non-sparking tools and use caution when removing or installing equipment to avoid generating a spark.

Parts Required:

- Conduit Bushing (P/N 410486-001),
- Hardware/Seal Kit (AG) (P/N 410154-001)

Procedure:

1. Remove the contractor's box cover (Figure 43 on page 48). Remove and discard the o-ring from the cover. Set aside the cover.

NOTICE

For all models with the 'RA' suffix, place the supplied plastic protector on the contractor's box cover prior to torquing (see Figure 15). By not using the protector, damage may occur to the powder coating, causing corrosion.

2. Locate the conduit bushing at the base of the contractor's box (see Figure 17 on page 22). Note that the incoming power wires connect to the pump wiring. Make a note of which incoming wire connects to which pump wire then disconnect the incoming power wires from the pump wires and set aside the wire nuts.
3. Loosen the two screws in the conduit bushing just enough so the bushing can be lifted from its socket in the bottom of the manifold's contractor box. Continue lifting the bushing up, until it is free of the power wires. Notice that the top plate of the bushing assembly (facing into the manifold) has a larger diameter than the bottom plate, and that there are plastic rod inserts in the unused holes. The plastic inserts seal the bushing and must be in any unused hole.
4. Orient the replacement bushing so the screws are facing up, and push each of the incoming power wires through an empty hole in the bushing. Leave the plastic rod inserts in any unused holes.
5. Slide the bushing down over the power wires until it seats in its socket in the base of the manifold's contractor box and then tighten the two screws in the top plate of the bushing assembly to compress the bushing and seal the wiring entry.
6. Reconnect the power wires to the pump wires as recorded in Step 2 above.
7. Get a 2.090" ID x 0.118" wide o-ring from the hardware/seal kit. Lubricate the o-ring with petroleum jelly and slide it over the cover's threads up to the flange. Reinstall the cover. Do not use thread sealant. Torque the cover to 35 ft-lbs (50 N•m).

NOTICE

For all models with the 'RA' suffix, place the supplied plastic protector on the contractor's box cover prior to torquing (see Figure 15). By not using the protector, damage may occur to the powder coating, causing corrosion.

Replacing the Pigtail

WARNING



Disconnect, lock out, and tag power at the panel before starting to service the pump.



When servicing equipment, use non-sparking tools and use caution when removing or installing equipment to avoid generating a spark.

Kits Required:

- UMP Replacement Kit P/N 144-327-4 (AG P/N 410818-001)
- Pigtail, P/N 410156-001
- Hardware/Seal Kit (AG), P/N 410154-001
- Die Spring Kit, P/N 410485-001 (P/N 410906-001 for 'RA' models)

Procedure:

1. If a ball valve is installed down line from the pump, close it.
2. Remove the two extractable lock-down nuts (see Figure 45). The springs on the lock-down studs between the extractable's flange and the manifold will push it up, breaking the seals.

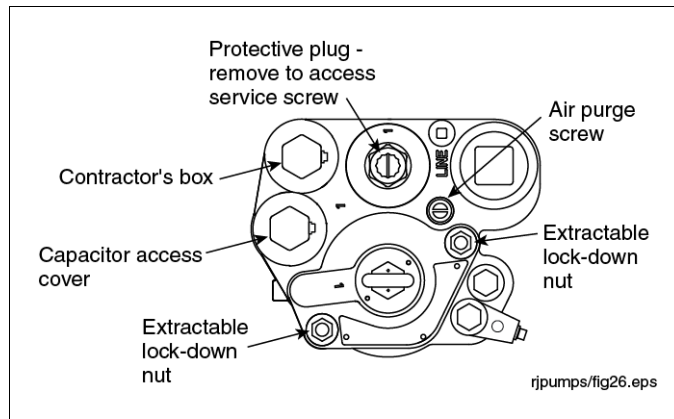

Figure 45. Extractable Lock-Down Nuts

WARNING

Confirm that the lifting eyebolt is properly torqued to 10 ft-lbs (13.6 N•m) with a minimum of 6 full threads installed. Occasionally, eyebolts are removed after pump installation and corrosion may occur in the threaded areas of the wiring compartment cover (eyebolt plug) and the eyebolt. If corrosion has occurred, the cover and eyebolt should be replaced.

3. Utilize the lifting eyebolt to lift out the extractable unit and place it on a clean surface. **Removal of the extractable section of the pump must be conducted with caution.** Make certain that the extractable section remains centered within the riser pipe and that no portion of the extractable binds during the removal process. If binding occurs during removal, stop and determine the cause of the binding and correct the situation before proceeding with removal.
4. Remove the UMP by removing the four bolts holding the discharge head as shown in Figure 40 on page 45. Discard the old gasket and fasteners.
5. Place the new gasket from the UMP replacement kit on the new UMP so that all the holes align.

CAUTION Gaskets from competitive UMPs will not seal properly and performance will be reduced.

6. Remove the packer wiring compartment cover. Remove and discard the o-ring from the cover and set aside the cover. Observe the three wiring connections in the compartment. Make a note of which wire from the packer connects to which wire from the pigtail (it should be like colored wires connecting to like colored wires). Disconnect the wires and set aside the wire nuts.

NOTICE For all models with the 'RA' suffix, place the supplied plastic protector on the packer wiring compartment cover prior to torquing (see Figure 15). By not using the protector, damage may occur to the powder coating, causing corrosion.

7. Look at the end of the discharge head. Pull the pigtail connector out of its socket in the discharge head and remove and discard the pigtail. Remove the o-ring in the sidewall of the connector's socket in the discharge head.
8. Get the new pigtail assembly and uncoil the pigtail so it lays flat.
9. Get a 0.551" ID x 0.070" wide o-ring from the hardware/seal kit. Lubricate the o-ring with petroleum jelly and insert it in the sidewall of the connector's socket in the end of the discharge head.
10. Push the pigtail wires into the connector's socket until they exit into the packer's wiring compartment. At the discharge (connector) end of the pigtail, rub some petroleum jelly over the connector's outside surface and push it into its socket in the discharge head. Take care to align the connector index tab with the notch in the socket as shown in the drawing on the right in Figure 41 on page 45.
11. Align the UMP positioning dowel so it inserts in the proper hole in the discharge head (again ref. Figure 41 on page 45) and push the UMP into position using hand force only. The UMP should be snug against the discharge head prior to installing the UMP retaining bolts.

WARNING Use hand force to push the UMP onto the discharge head. If the UMP does not seat snug against the discharge head, remove the UMP and correct the problem.

12. Install the four UMP retaining bolts and lock washers. Snug and then torque the bolts using a cross pattern technique to 7 ft-lbs (11 N•m).

WARNING .Do not over torque the bolts. Not following these instructions may cause parts to fail.

13. Carefully pull on the pigtail wires where they exit the packer wiring compartment until any excess length is out of the column pipe. Cut off the pigtail wires approximately 8 inches (200 mm) beyond the top of the packer.
14. Strip insulation off the three pigtail wires 3/8 inch (10 mm).
15. Connect like colored wires from the pigtail to like colored wires from the packer connector with wire nuts. When finished connecting the wires, neatly coil wires inside the packer's wiring compartment (see Figure 16 on page 21).
16. Get a 2.090" ID x 0.118" wide o-ring from the hardware/seal kit. Lubricate the o-ring on the packer wiring compartment cover (with lifting eyebolt) with petroleum based jelly. Screw in the packer wiring compartment cover (thread sealant should not be used) and torque to 35 ft-lbs (48 N•m).

NOTICE For all models with the 'RA' suffix, place the supplied plastic protector on the packer wiring compartment cover prior to torquing (see Figure 15). By not using the protector, damage may occur to the powder coating, causing corrosion.

17. Get the three extractable o-ring seals (3.975" ID x 0.210" wide [upper], 3.850" ID x 0.210" wide [middle], and 3.725" x 0.210" wide [lower]) from the hardware/seal kit. The three o-rings are very close in size so take extra care to distinguish each one before replacing them in the extractable. Lubricate each o-ring with petroleum jelly and then install them in their assigned grooves in the extractable - see Figure 42 on page 47.
18. Remove the manifold's female connector's o-ring - see Figure 42 on page 47. Get a 0.862" ID x 0.103" wide o-ring from the kit and lubricate it with petroleum jelly. Slide the o-ring over the female connector and push it down into its groove.

19. Reinstall the extractable unit into the manifold and tank. Torque the extractable lock-down nuts in an alternating pattern to 50 ft-lbs (68 N•m).

NOTICE Remove the springs around the lock-down studs and replace with the springs from the kit.

For all models with the 'RA' suffix, stainless steel lock-down nuts and washers are used and found in the kit. Apply anti-seize (also found in the kit) to the lock-down studs prior to nut and washer installation.

20. Turn the air purge screw 2 - 3 turns counterclockwise (see Figure 45).

⚠WARNING The air purge screw is retained by a hitch pin to limit travel. Do not attempt to rotate beyond 3 turns.

21. Turn the pump on and let it run for about 2 minutes to purge air from the manifold's hydraulic cavities. While the pump is still running, turn the air purge screw clockwise until it is completely closed.
22. If applicable, open the ball valve down line from the pump.

Replacing the Packer-to-Manifold Wiring Connectors

▲WARNING



Disconnect, lock out, and tag power at the panel before starting to service the pump.



When servicing equipment, use non-sparking tools and use caution when removing or installing equipment to avoid generating a spark.

Kits Required:

- Electrical Connector kit, P/N 410165-001
- Hardware/Seal Kit (AG), P/N 410154-001
- Die Spring Kit, P/N 410485-001 (P/N 410906-001 for 'RA' models)

Special tools - not supplied in kits:

- 3/16" hex wrench, medium point felt-tip pen, small piece of masking tape, small ruler and needle-nose pliers

Procedure:

1. If a ball valve is installed down line from the pump, close it.
2. Remove the two extractable lock-down nuts (see Figure 39 on page 44). The springs on the lock-down studs between the extractable's flange and the manifold will push it up, breaking the seals.

▲WARNING

Confirm that the lifting eyebolt is properly torqued to 10 ft-lbs (13.6 N•m) with a minimum of 6 full threads installed. Occasionally, eyebolts are removed after pump installation and corrosion may occur in the threaded areas of the wiring compartment cover (eyebolt plug) and the eyebolt. If corrosion has occurred, the cover and eyebolt should be replaced.

3. Utilize the lifting eyebolt to lift out the extractable unit and place it on a clean surface. **Removal of the extractable section of the pump must be conducted with caution.** Make certain that the extractable section remains centered within the riser pipe and that no portion of the extractable binds during the removal process. If binding occurs during removal, stop and determine the cause of the binding and correct the situation before proceeding with removal.
4. Remove the packer wiring compartment cover (see Figure 42 on page 47). Remove and discard the o-ring from the cover and set aside the cover. Observe the three wiring connections inside the compartment. Make a note of which wire from the packer connects to which wire from the pigtail (it should be like colored wires connecting to like colored wires). Disconnect the wires and set aside the wire nuts.

NOTICE

For all models with the 'RA' suffix, place the supplied plastic protector on the packer wiring compartment cover prior to torquing (see Figure 15). By not using the protector, damage may occur to the powder coating, causing corrosion.

5. Locate the male connector inside the packer (see Figure 46).
6. Place a mark on the facing of the Packer using a felt pen to indicate the position of the index hole (see Figure 48).

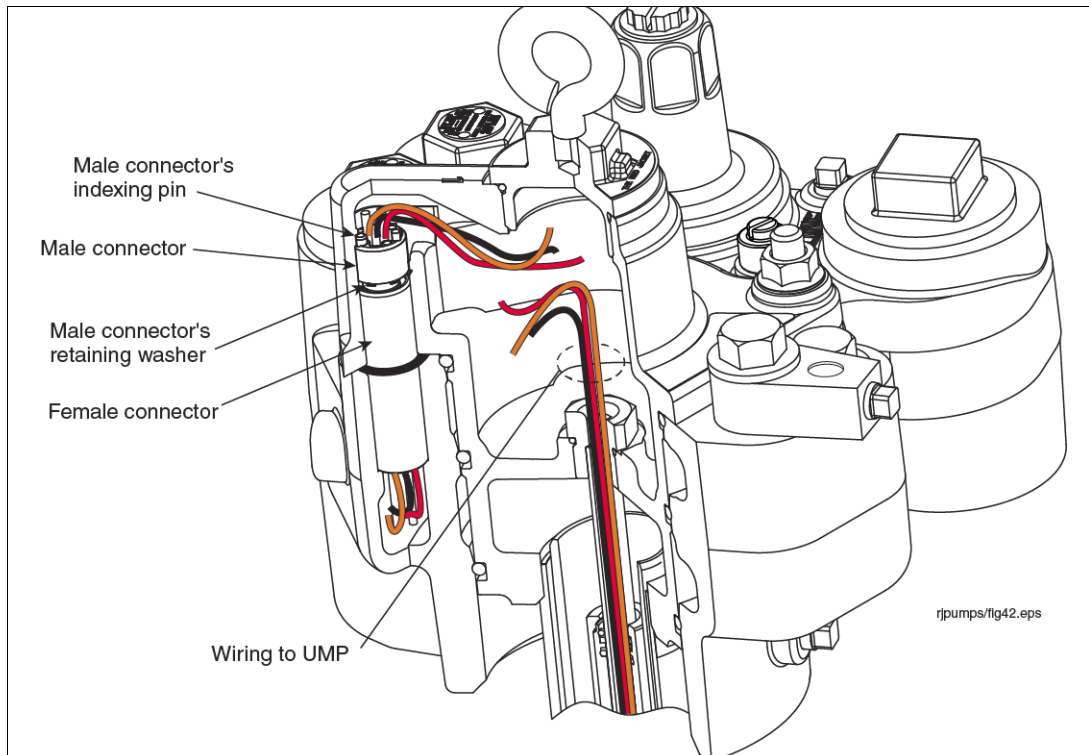

Figure 46. Packer-To-Manifold Wiring Connectors

7. Use a pair of needle-nose pliers to remove the retaining washer that holds the male connector in its socket.
8. Remove the male connector.
9. Get the new male connector and retaining washer from the electrical connector kit.
10. Notice the small indexing pin on the back of the male connector (see Figure 47).

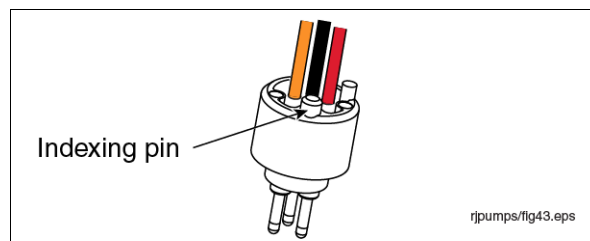

Figure 47. Male Connector's Indexing Pin

11. The indexing pin on the back of the connector must seat in the index hole in the base of the male connector's socket (see Figure 48) for the connector to be correctly oriented relative to the female connector.

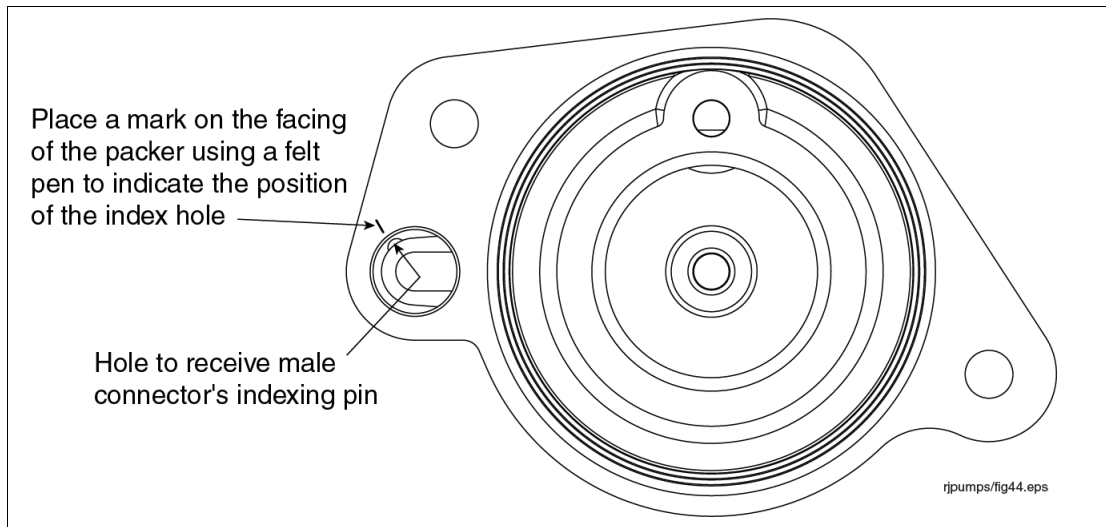

Figure 48. Male Connector Index Hole In Base Of Socket

12. Place a small piece of masking tape on the pins side of the connector inline with the indexing pin (see Figure 49).

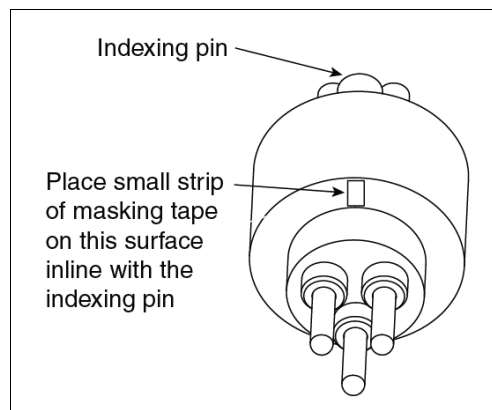

Figure 49. Placing Masking Tape Alignment Marker On Front Of Male Connector

13. Thread the wires of the new male connector down into the socket and out through the opening in the base of the socket into the packer wiring compartment. Gently pull the wires into the wiring compartment as you align the masking tape mark on the connector with the felt tip mark on the packer facing. When you have pushed the connector all the way into its socket it should not rotate if the indexing pin is in the index hole. Using the small ruler, measure the distance from the packer facing down to the connector, it should be a little more than 1-3/8" (35mm) (see Figure 50). Hold the wires tight to keep the connector in position and insert the retaining washer (with upturned teeth facing out) forcing it down until it is firmly against the connector. Recheck the 1-3/8" (35mm) measurement after installing the retaining washer to confirm that the connector is at the proper depth.

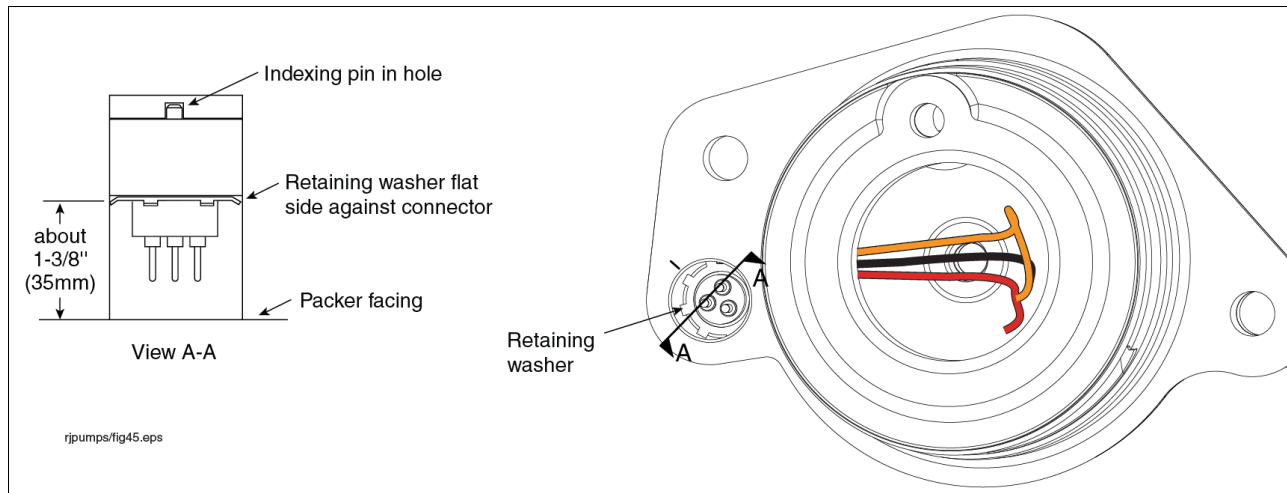

Figure 50. Correct Depth Of Male Connector In Packer Socket

14. Strip back insulation off the three connector wires 3/8 inch (10mm).
15. Connect like colored wires from the pigtail to like colored wires from the packer male connector with wire nuts (Note: refer to notes made in Step 4 before connecting these wires). When finished connecting the wires, neatly coil wires inside the packer's wiring compartment (see Figure 16 on page 21).
16. Get a 2.090" ID x 0.118" wide o-ring from the hardware/seal kit. Lubricate the o-ring on the packer wiring compartment cover (with lifting eyebolt) with petroleum based jelly. Screw in the packer wiring compartment cover (thread sealant should not be used) and torque to 35 ft-lbs (50 N•m).
17. Remove capacitor access cover (see Figure 43 on page 48). Remove and discard the o-ring from the cover and set aside the cover. Observe the three wiring connections from the female connector. Make a note of which wire from the connector connects to which wire from the capacitor and incoming power wiring. Disconnect the female connector wires and set aside the wire nuts.

NOTICE For all models with the 'RA' suffix, place the supplied plastic protector on the capacitor access cover prior to torquing (see Figure 15). By not using the protector, damage may occur to the powder coating, causing corrosion.

18. Using a 3/16" hex wrench, turn the set screw that holds the female connector in place about 1-1/2 turns counterclockwise until you can lift out the connector (see Figure 51).

WARNING Do not try to remove the set screw.

19. Get the new female connector and its 0.862" ID x 0.103 wide o-ring from the kit. Push the three wires coming out of the connector down through the opening in the base of its socket and into the capacitor well. As you pull on its wires in the capacitor well, lower the connector with the flat cut in the side of the connector facing its retaining set screw. With the connector as far down as it can go (sitting on the ridge in the base of its socket), tighten the set screw firmly against the connector. As the set screw tightens it should rotate the connector to its proper position relative to the male connector.
20. Reconnect the connector's three wires as per your notes made in Step 17 above.
21. Get a 2.090" ID x 0.118" wide o-ring from the hardware/seal kit and lubricate with petroleum jelly. Insert this o-ring on the capacitor cover and screw in the cover. Do not use thread sealant. Torque the cover to 35 ft-lbs (50 N•m).

NOTICE For all models with the 'RA' suffix, place the supplied plastic protector on the capacitor access cover prior to torquing (see Figure 15). By not using the protector, damage may occur to the powder coating, causing corrosion.

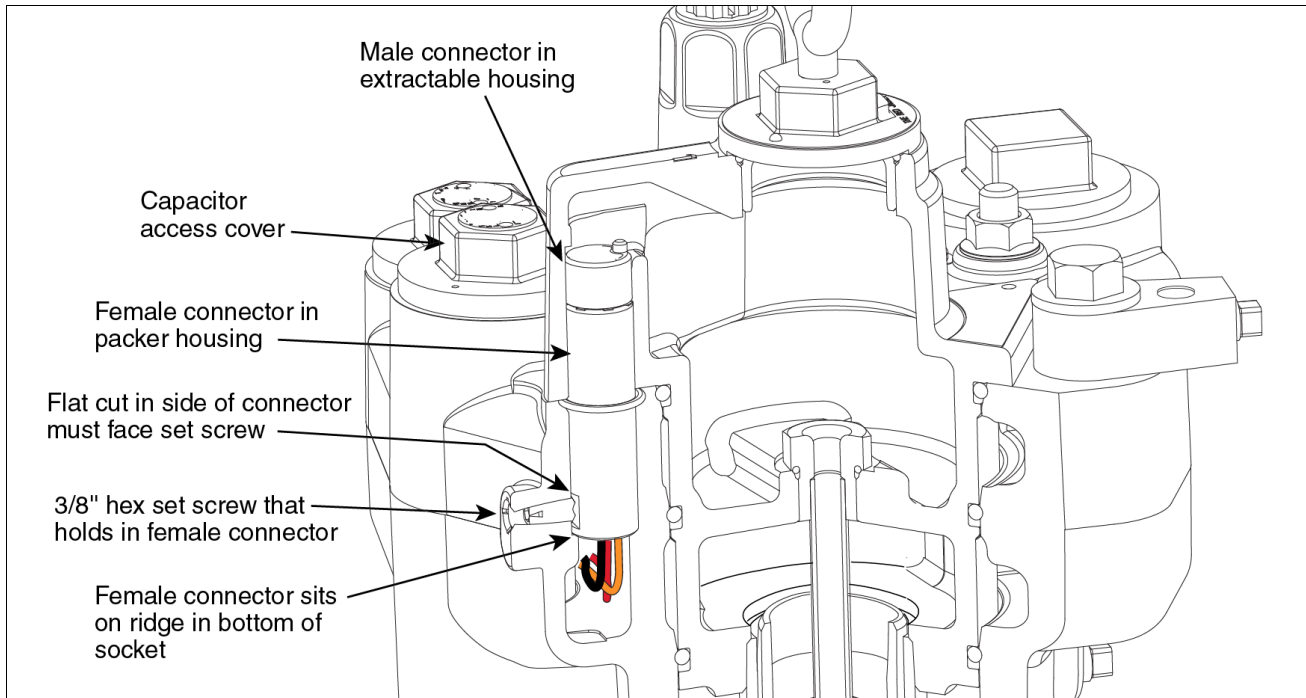

Figure 51. Locating Female Connector Set Screw

22. Remove the manifold's female connector's o-ring. Get the 0.862" ID x 0.103" wide o-ring from the connector kit and lubricate it with petroleum jelly. Insert this o-ring in its groove in the manifold around the female connector (see Figure 46 on page 56).
23. Get the three extractable o-ring seals (3.975" ID x 0.210" wide [upper], 3.850" ID x 0.210" wide [middle], and 3.725" x 0.210" wide [lower]) from the hardware/seal kit. The three o-rings are very close in size so take extra care to distinguish each one before replacing them in the extractable. Lubricate each o-ring with petroleum jelly and then install them in their assigned grooves in the extractable (see Figure 42 on page 47).
24. Reinstall the extractable unit into the manifold and tank. Torque the extractable lock-down nuts in an alternating pattern to 50 ft-lbs (68 N•m).

NOTICE Remove the springs around the lock-down studs and replace with the springs from the kit.

For all models with the 'RA' suffix, stainless steel lock-down nuts and washers are used and found in the kit. Apply anti-seize (also found in the kit) to the lock-down studs prior to nut and washer installation.

25. Turn the air purge screw 2 - 3 turns counterclockwise (see Figure 52).

▲WARNING The air purge screw is retained by a hitch pin to limit travel. Do not attempt to rotate beyond 3 turns.

26. Turn the pump on and let it run for about 2 minutes to purge air from the manifold's hydraulic cavities. While the pump is still running, turn the air purge screw clockwise until it is completely closed.
27. If applicable, open the ball valve down line from the pump.

Replacing the Air Purge Screw

WARNING



Disconnect, lock out, and tag power at the panel before starting to service the pump.



When servicing equipment, use non-sparking tools and use caution when removing or installing equipment to avoid generating a spark.

Kits Required:

- Air Purge Screw Kit (P/N 410484-001),
- Hardware/Seal Kit (AG) (P/N 410154-001)

Special tool required: T-handle 1/4" hex drive

Procedure:

1. If a ball valve is installed down line from the pump, close it.
2. Remove and save the protective plug in the top of the check valve housing and turn the service screw clockwise (see Figure 52). As the screw approaches its bottom position, you will hear the system depressurizing. Continue turning the screw until it can go no further. When the screw is all the way down, backoff the screw 4 turns to lift the check valve and let the fuel drain out of the manifold's hydraulic cavities.
3. Unscrew the check valve housing. Notice that the check valve and spring are still attached to the service screw. Remove and discard the housing o-ring (see Figure 44 on page 50). Set the housing/check valve assembly aside.

NOTICE For all models with the 'RA' suffix, place the supplied plastic protector on the check valve cover prior to torquing (see Figure 15). By not using the protector, damage may occur to the powder coating, causing corrosion.

4. Remove the 2" NPT plug, LLD transducer, or MLLD from the line leak detector port in the manifold. Remove the o-ring from the device and discard.

NOTICE For all models with the 'RA' suffix, place the supplied plastic protector on the 2" NPT plug prior to torquing (see Figure 15). By not using the protector, damage may occur to the powder coating, causing corrosion.

5. Locate the air purge screw on the top of the manifold (Figure 52).

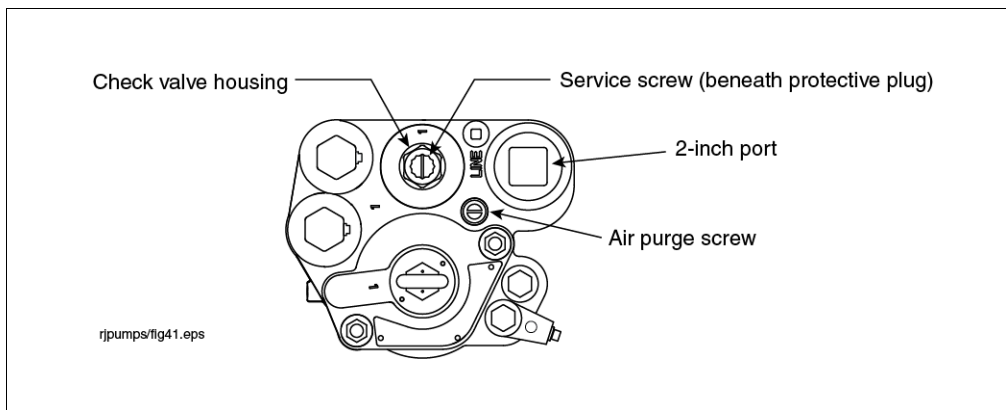

Figure 52. Locating Air Purge Screw

6. The air purge screw has a hitch pin that is set in the horizontal position to limit travel of the screw (see Figure 53).
7. Accessing the hitch pin through the check valve port, use your forefinger to push the pin all the way in as far as you can. As you unscrew the screw, the pin will be forced down into the vertical position as it contacts the surface of the manifold's cavity.
8. Lubricate the three o-rings on the new screw with petroleum jelly and install it with the hitch pin pushed on and hanging in the vertical position (see Figure 55).

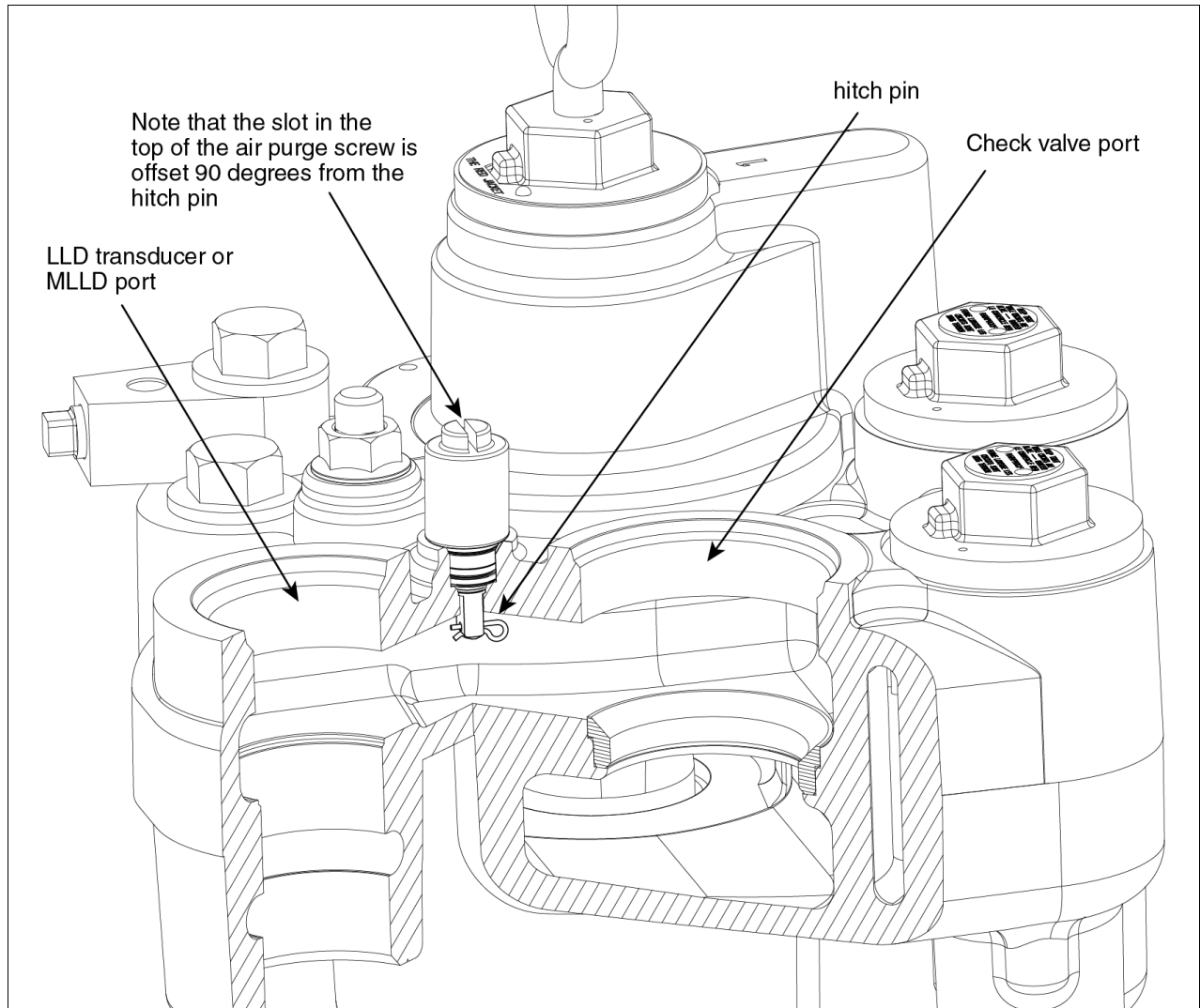

Figure 53. Locating Air Purge Screw Hitch Pin

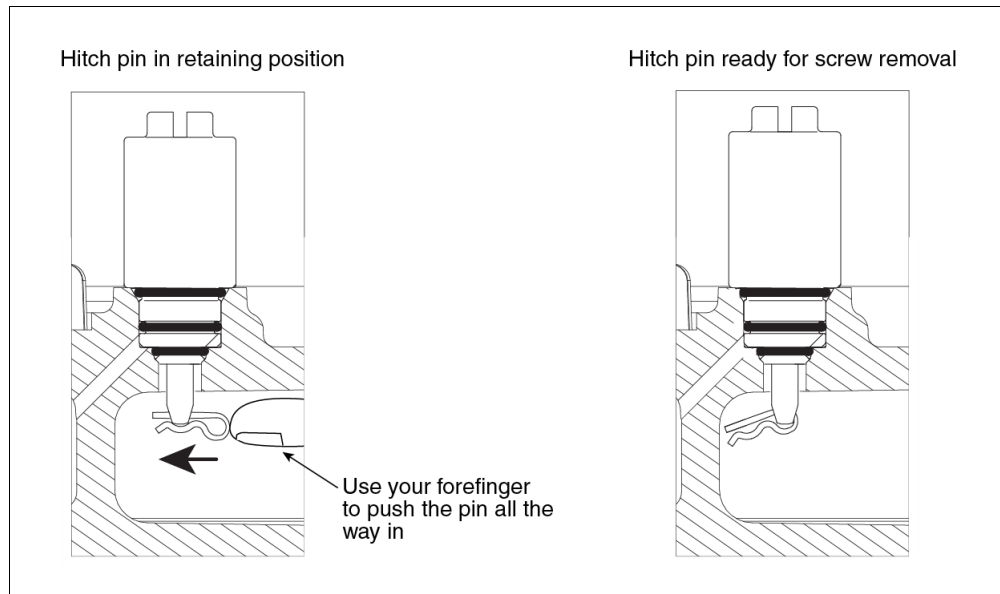

Figure 54. Reorienting The Air Purge Screw's Hitch Pin

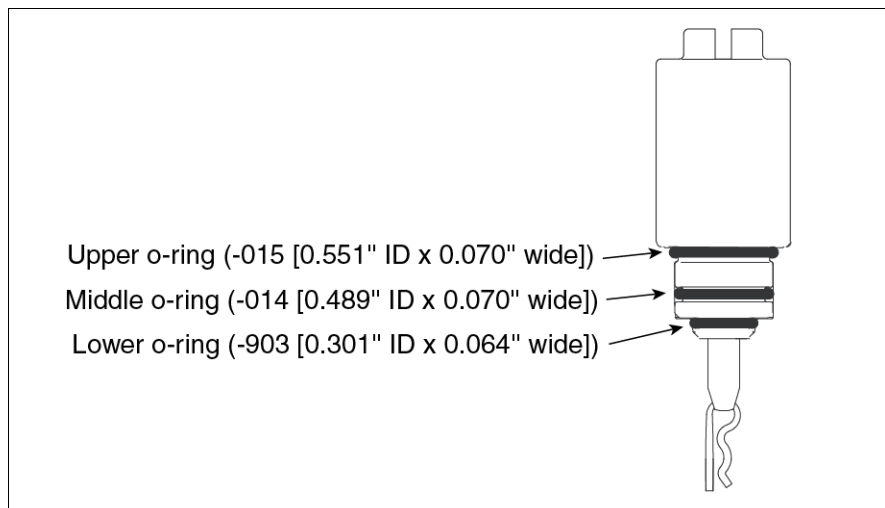

Figure 55. Hitch Pin In Position To Install Air Purge Screw

9. When the screw is turned clockwise all the way down, but not tight, use the forefinger of one hand to push the hitch pin up as shown in diagram 1 of Figure 56.
10. While holding the hitch pin up with the forefinger of one hand, place the gloved forefinger of your other hand against the end of the pin as shown in diagram 2 of Figure 56.
11. Push the end of the pin with the gloved forefinger until it snaps into the retaining position as shown in diagram 3 of Figure 56.

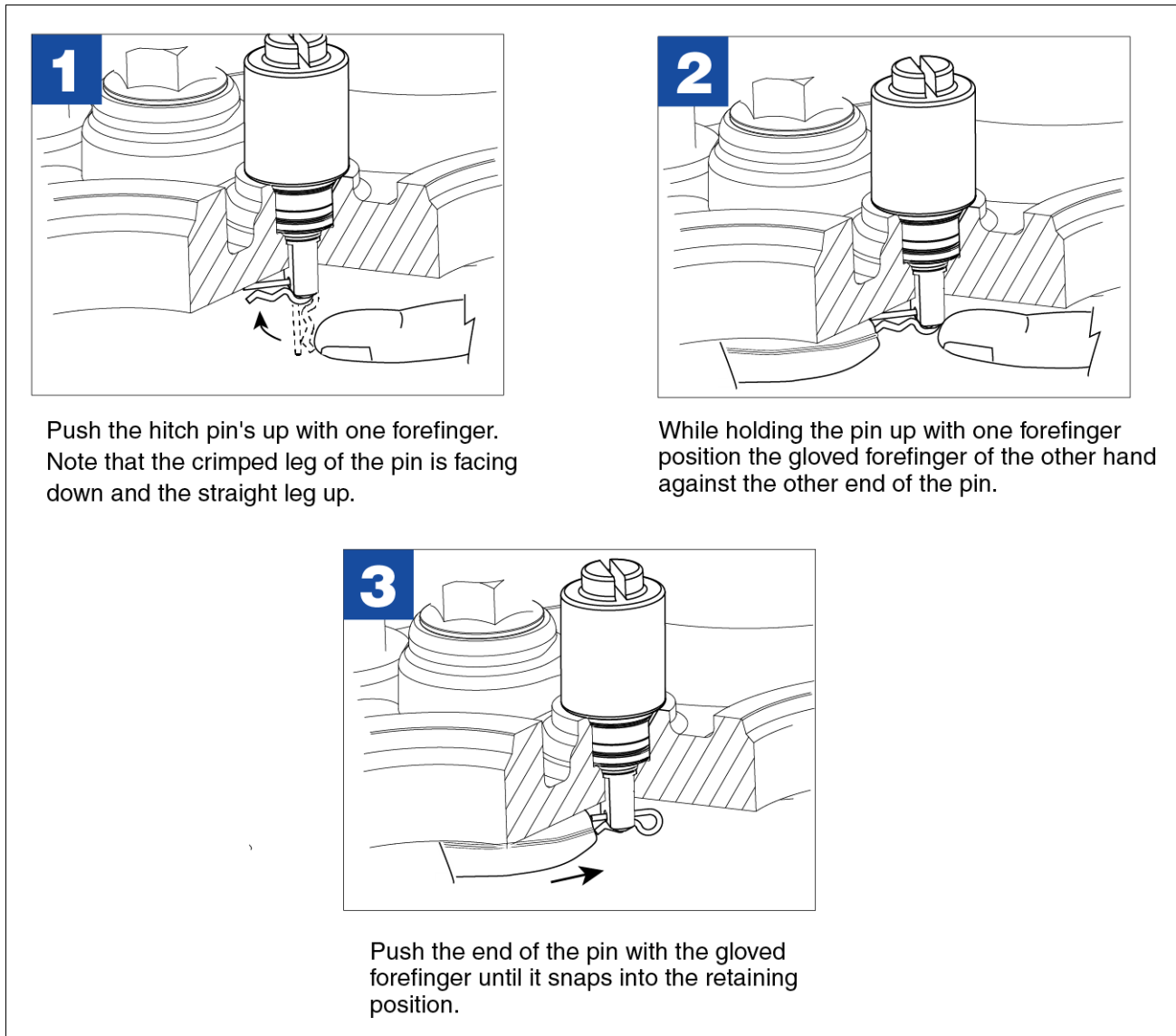

Figure 56. Installing Air Purge Screw Hitch Pin In The Retaining Position

- If you removed the 2" NPT plug to access the screw, get a new 2.234" ID x 0.139" wide o-ring from the hardware/seal kit and install it on the 2" NPT plug. Lubricate the o-ring with petroleum jelly and install the plug into the leak detector port. Torque the plug to 20 - 50 ft-lbs (27 - 67 N•m).

NOTICE For all models with the 'RA' suffix, place the supplied plastic protector on the 2" NPT plug prior to torquing (see Figure 15). By not using the protector, damage may occur to the powder coating, causing corrosion.

If you removed a line leak detector to access the air purge screw, apply an adequate amount of fresh, UL classified for petroleum, non-setting thread sealant to the threads of the leak detection device and screw it into the 2" port. Torque the device until leak free.

- Get a new check valve housing o-ring (2.609" ID x 0.139" wide) from the hardware/seal kit. Lubricate the o-rings with petroleum jelly and install it on the valve as shown in Figure 44 on page 50.

14. Screw the check valve into its port in the manifold. Torque the housing to 20 - 50 ft-lbs (27 - 67 N•m). Turn the service screw all the way up (CCW). You will hear the check valve drop into position just before the screw is all the way up. Replace the protective plug over the service screw and fully thread into place to ensure a good seal.

NOTICE **NOTE: For all models with the 'RA' suffix, place the supplied plastic protector on the check valve housing prior to torquing (see Figure 15). By not using the protector, damage may occur to the powder coating, causing corrosion.**

15. Screw the air purge screw all the way down (cw), then back it off 2 - 3 turns counterclockwise.

⚠ WARNING **The air purge screw is retained by the hitch pin to limit travel. Do not attempt to rotate beyond 3 turns.**

16. Turn the pump on and let it run for about 2 minutes to purge air from the manifold's hydraulic cavities. While the pump is still running, turn the air purge screw clockwise until it is completely closed.
17. Open the ball valve down line from the pump.

Parts Lists

Customer Service Number

After unpacking the equipment, please inspect the parts. Make sure all accessories are included and that no damage occurred during shipping. Report any damage to the shipper immediately and inform a customer service representative at 1-800-873-3313 of any equipment damage or missing parts.

Pump Parts

Table 8 lists the domestic pump parts list and Table 9 lists the international pump parts list.

Table 8. Domestic Pump Parts List

Item (ref. Figure 57)	Part No.	Description	DOM
1	410156-001	20 ft. pigtail	1
2	852-025-5	UMP75U1 W/FSA	1
2	852-042-5	UMP150U1 W/FSA	1
2	852-084-5	AGUMP75S1	1
2	852-199-5	UMP75U1	1
2	852-085-5	AGUMP150S1	1
2	852-200-5	UMP150U1	1
2	852-135-5	AGUMP75S1 W/FSA	1
2	852-136-5	AGUMP150S1 W/FSA	1
2	852-128-5	X3AGUMP150S1	1
2	852-202-5	X3UMP150U1	1
2	852-132-5	X3AGUMP150S1 W/FSA	1
2	852-203-5	X3UMP150U1 W/FSA	1
2	852-221-5	UMP200U1-3	1
2	410184-073	UMPL200U1-3	1
2	410184-075	UMPL200U1-3 W/FSA	1
2	852-222-5	AGUMP200S1-3	1
2	410184-074	AGUMPL200S1-3	1
2	410184-076	AGUMPL200S1-3 W/FSA	1
2	852-223-5	UMP200U1-3 W/FSA	1
2	852-224-5	AGUMP200S1-3 W/FSA	1
3	144-327-4	Kit - flex siphon/UMP (includes gasket, lockwashers and bolts)	1
---	144-194-5	Trapper - retrofit (not shown)	1
2	852-198-5	UMP33R1	1
2	852-024-5	UMP33R1 w/FSA	1
2	852-083-5	AGUMP33R1	1

Table 8. Domestic Pump Parts List

Item (ref. Figure 57)	Part No.	Description	DOM
2	852-134-5	AGUMP33R1 w/FSA	1
3	410818-001	Kit - flex siphon/UMP AG (includes gasket, lockwashers and bolts)	1

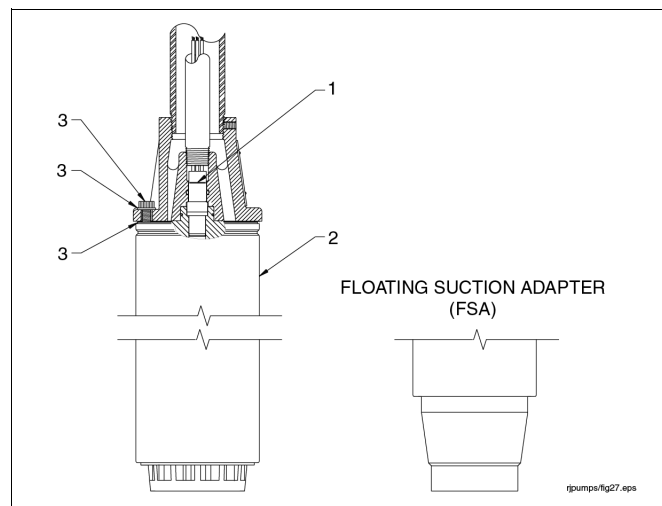

Figure 57. Pump Parts

Table 9. International Pump Parts List

Item (ref. Figure 57)	Part No.	Description	INTL
1	410156-001	20 ft. pigtail	1
2	852-204-5	UMP75U3-3	1
2	852-205-5	UMP150U3-3	1
2	852-206-5	UMP75U3-3 W/FSA	1
2	852-207-5	UMP150U3-3 W/FSA	1
2	852-107-5	AGUMP75S3-3	1
2	852-111-5	AGUMP75S3-3 W/FSA	1
2	852-108-5	AGUMP150S3-3	1
2	852-112-5	AGUMP150S3-3 W/FSA	1
2	852-192-5	UMP75U3-3 W/2" Discharge head	1
2	852-193-5	UMP150U3-3 W/2" Discharge head	1
2	852-194-5	X4UMP150U3 W/2" Discharge head	1
2	410184-034	UMP75U17-3 W/2" Discharge head	1
2	410184-036	UMP150U17-3 W/2" Discharge head	1
2	410184-038	X4UMP150U17 W/2" Discharge head	1

Table 9. International Pump Parts List

Item (ref. Figure 57)	Part No.	Description	INTL
2	410184-033	UMP75U17-3	1
2	410184-035	UMP150U17-3	1
2	410184-041	AGUMP75S17-3	1
2	410184-043	AGUMP150S17-3	1
2	410184-053	AGUMP75S17-3 W/FSA	1
2	410184-054	AGUMP150S17-3 W/FSA	1
2	852-153-5	X4UMP150U3	1
2	852-154-5	X4UMP150U3 W/FSA	1
2	410184-037	X4UMP150U17	1
2	410184-051	X4UMP150U17 W/FSA	1
2	852-215-5	X4AGUMP150S3	1
2	852-216-5	X4AGUMP150S3 W/FSA	1
2	410184-045	X4AGUMP150S17	1
2	410184-055	X4AGUMP150S17 W/FSA	1
2	410184-049	UMP75U17-3 W/FSA	1
2	410184-050	UMP150U17-3 W/FSA	1
2	410184-005	UMP200U3-4	1
2	410184-001	AGUMP200S3-4	1
2	410184-039	UMP200U17-4	1
2	410184-047	AGUMP200S17-4	1
2	410184-007	UMP200U3-4 W/2" Discharge Head	1
2	410184-040	UMP200U17-4 W/2" Discharge Head	1
2	410184-011	UMP200U3-4 W/FSA	1
2	410184-052	UMP200U17-4 W/FSA	1
2	410184-009	AGUMP200S3-4 W/FSA	1
2	410184-056	AGUMP200S17-4 W/FSA	1
2	410184-042	AGUMP75S17-3 W/ 2" Discharge Head	1
2	410184-044	AGUMP150S17-3 W/2" Discharge Head	1
2	410184-046	X4AGUMP150S17 W/2" Discharge Head	1
2	410184-048	AGUMP200S17-4 W/2" Discharge Head	1
2	410184-057	ANZEx-UMP75U17-3	1
2	410184-058	ANZEx-UMP150U17-3	1
2	410184-059	ANZEx-X4UMP150U17	1
2	410184-060	ANZEx-UMP200U17-4	1

Table 9. International Pump Parts List

Item (ref. Figure 57)	Part No.	Description	INTL
2	410184-061	ANZEX-AGUMP75S17-3	1
2	410184-062	ANZEX-AGUMP150S17-3	1
2	410184-063	ANZEX-X4AGUMP150S17	1
2	410184-064	ANZEX-AGUMP200S17-4	1
2	410184-065	ANZEX-UMP75U17-3 W/FSA	1
2	410184-066	ANZEX-UMP150U17-3 W/FSA	1
2	410184-067	ANZEX-X4UMP150U17 W/FSA	1
2	410184-068	ANZEX-UMP200U17-4 W/FSA	1
2	410184-069	ANZEX-AGUMP75S17-3 W/FSA	1
2	410184-070	ANZEX-AGUMP150S17-3 W/FSA	1
2	410184-071	ANZEX-X4AGUMP150S17 W/FSA	1
2	410184-072	ANZEX-AGUMP200S17-4 W/ FSA	1
	410145-001	PACMAN-P75U3-3 (packaged) - 20%	1
	410146-001	PACMAN-P75U17-3 (packaged) - 20%	1
	410147-001	PACMAN-P150U3-3 (packaged) - 20%	1
	410148-001	PACMAN-P150U17-3 (packaged) - 20%	1
	410149-001	PACMAN-X4P150U3 (packaged) - 20%	1
	410150-001	PACMAN-X4P150U17 (packaged) - 20%	1
	410162-001	PACMAN-P200U3-4 (packaged) - 20%	1
	410163-001	PACMAN-P200U17-4 (packaged) - 20%	1
	410161-001	Seal - conduit adapter assembly	1
3	144-327-4	Kit - flex syphon/UMP (includes gasket, lockwashers and bolts)	1
	144-194-5	Trapper - retrofit (not shown)	1
3	410818-001	Kit - flex siphon/UMP AG (includes gasket, lockwashers and bolts)	1

Siphon Cartridge Kit Parts

Table 10 lists the 410151-001 Siphon Cartridge Kit and 410151-002 AG Siphon Cartridge Kit parts list.

Table 10. Siphon Cartridge Kits Parts List

P/N 410151-001 SIPHON CARTRIDGE KIT			
Item (ref. Figure 58)	Part No.	Description	Qty.
1	410255-001	Siphon assembly	1
P/N 410151-002 AG SIPHON CARTRIDGE KIT			
Item (ref. Figure 58)	Part No.	Description	Qty.
1	410255-002	AG Siphon assembly	1

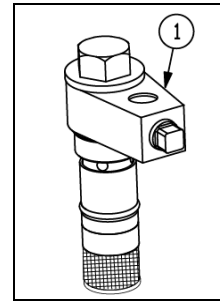

Figure 58. Siphon Cartridge Kit

Check Valve Housing Kit Parts

Table 11 lists the 410152-001 Check Valve Housing Kit, 410152-002 High Pressure Check Valve Housing Kit, 410152-005 RA Check Valve Housing Kit and 410512-006 RA High Pressure Check Valve Housing Kit parts lists.

Table 11. Check Valve Housing Kits Parts Lists

P/N 410152-001 Check Valve Housing Kit Parts List				P/N 410152-002 High Pressure Check Valve Housing Kit Parts List			
Item (ref. Figure 59)	Part No.	Description	Qty.	Item (ref. Figure 59)	Part No.	Description	Qty.
1	410016-002	Housing assembly - chk/r/f vlv	1	1	410016-002	Housing assembly - chk/r/f vlv	1
2	410753-001	Spring	1	2	410753-001	Spring	1
3	410022-005	Poppet assembly - chk/r/f vlv	1	3	410022-006	Poppet assembly - chk/r/f vlv	1
P/N 410152-005 RA Check Valve Housing Kit Parts List				P/N 410152-006 RA High Pressure Check Valve Housing Kit Parts List			
Item (ref. Figure 59)	Part No.	Description	Qty.	Item (ref. Figure 59)	Part No.	Description	Qty.
1	410016-004	Housing assembly - chk/r/f vlv	1	1	410016-004	Housing assembly - chk/r/f vlv	1
2	410753-001	Spring	1	2	410753-001	Spring	1
3	410022-005	Poppet assembly - chk/r/f vlv	1	3	410022-006	Poppet assembly - chk/r/f vlv	1
4	410908-001	Powder coat protector	1	4	410908-001	Powder coat protector	1

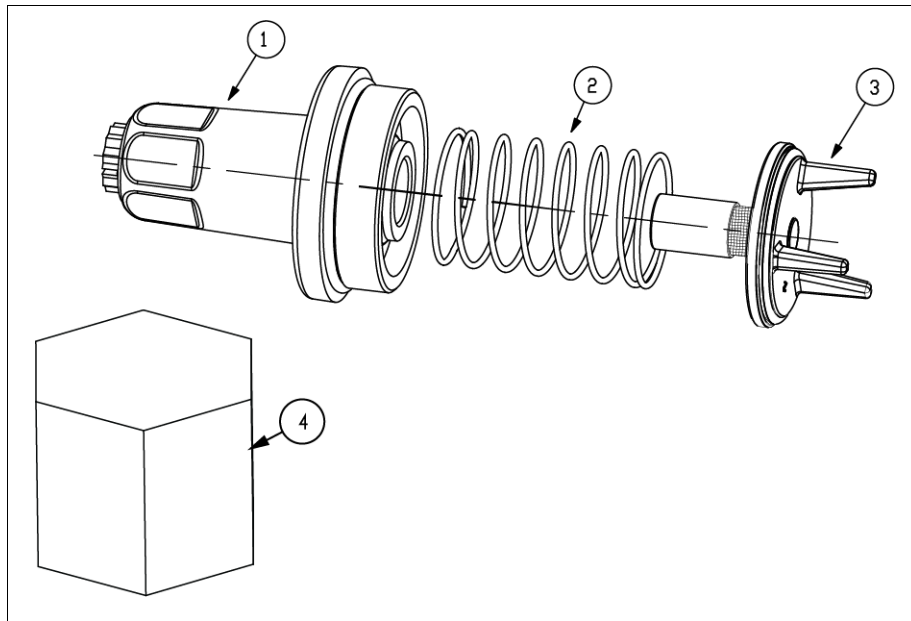

Figure 59. Check Valve Housing Kit

Check Valve Kit Parts

Table 12 lists the 410153-001 Check Valve Kit parts list.

Table 12. 410153-001 Check Valve Kit Parts List

Item (ref. Figure 60)	Part No.	Description	Qty.
1	410022-005	Poppet assembly - chk/r/f vlv	1
2	410753-001	Spring	1

Table 13 lists the 410153-002 Hi Pressure Check Valve Kit parts list.

Table 13. 410153-002 Hi Pressure Check Valve Kit Parts List

Item (ref. Figure 60)	Part No.	Description	Qty.
1	410022-006	Hi press poppet assembly - chk/r/f vlv	1
2	410753-001	Spring	1

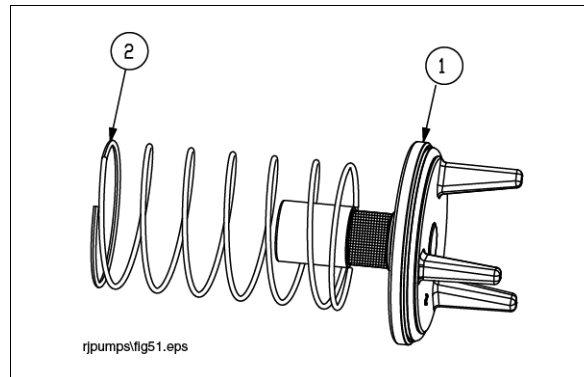

Figure 60. Check Valve Kit

Air Purge Screw Kit Parts

Table 14 lists the 410484-001 Air Purge Screw Kit parts list.

Table 14. 410484-001 Air Purge Screw Kit Parts List

Item (ref. Figure 61)	Part No.	Description	Qty.
1	410064-001	O-ring-015-FKM	1
2	410134-002	Screw - air purge - SST	1
3	579005-007	O-ring-014-FKM	1
4	579005-009	O-ring-903-FKM	1
5	579014-002	Clip - hitch pin clip- SST	1

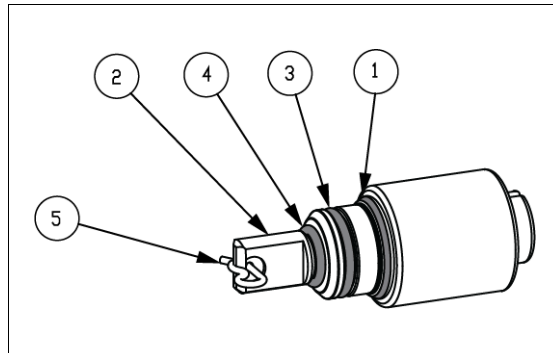

Figure 61. Air Purge Screw Kit

Die Spring Kit Parts

Table 15 lists the 410485-001 Die Spring Kit parts list.

Table 15. 410485-001 Die Spring Kit Parts List

Item (ref. Figure 62)	Part No.	Description	Qty.
1	410133-001	Die spring	2

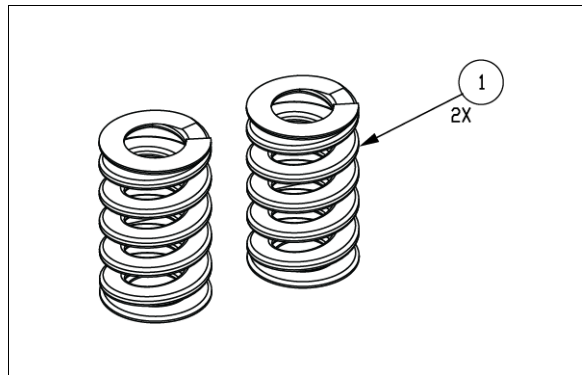

Figure 62. Die Spring Kit

RA Die Spring Kit Parts

Table 16 lists the 410906-001 RA Die Spring Kit parts list.

Table 16. 410906-001 RA Die Spring Kit Parts List

Item (ref. Figure 63)	Part No.	Description	Qty.
1	410133-002	Spring - die, stainless steel	2
2	579301-001	Washer - flat-531 x 1.062 x 0.095, stainless steel	2
3	410823-001	Nut - hex stud cover	2
4	579165-001	Anti-seize compound - metal free - stick - 20g	1

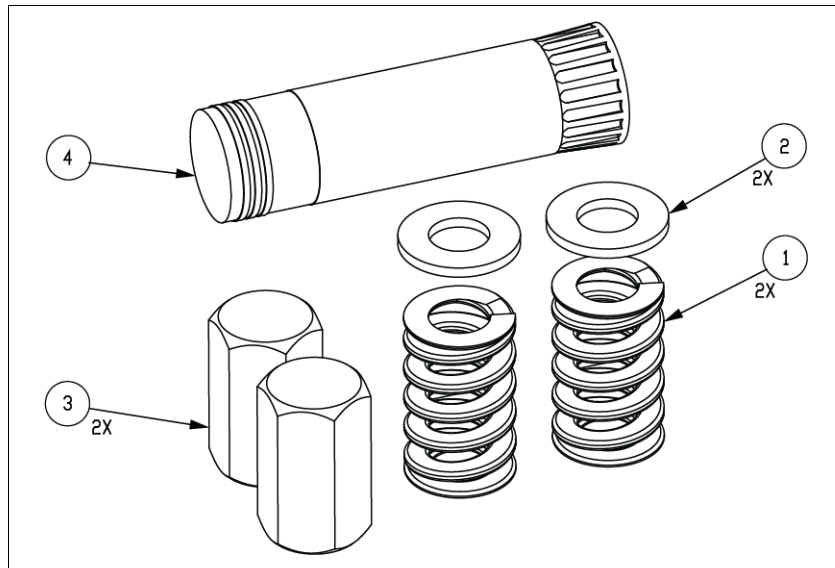

Figure 63. RA Die Spring Kit

Conduit Box Plug Kit Parts

Table 17 lists the 067-258-5 Conduit Box Plug (STD) Kit parts list.

Table 17. 067-258-5 Conduit Box Plug (STD) Kit Parts List

Item (ref. Figure 64)	Part No.	Description	Qty.
1	067-258-4	Conduit plug assembly (STD)	1

Table 18 lists the 067-259-5 Conduit Box Plug (AG) Kit parts list.

Table 18. 067-259-5 Conduit Box Plug (AG) Kit Parts List

Item (ref. Figure 64)	Part No.	Description	Qty.
1	067-259-4	Conduit plug assembly (AG)	1

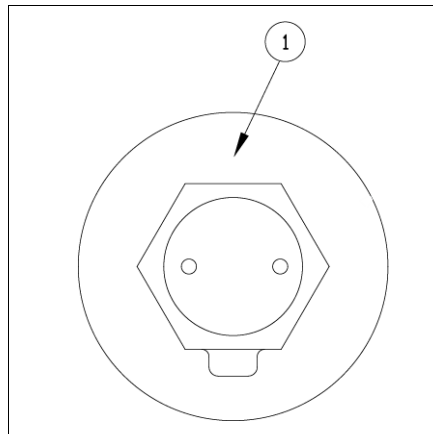

Figure 64. Conduit Box Plug Kit

Table 19 lists the 410905-001 RA Conduit Box Plug Kit parts list.

Table 19. 410905-001 RA Conduit Box Plug Kit Parts List

Item (ref. Figure 65)	Part No.	Description	Qty.
1	410855-001	Plug-conduit box - powder coated	1
2	072-656-1	O-Ring- 1.750 I.D. x 0.118 W (-928)-FMK	1
3	410695-002	Nameplate-conduit box cover-SST	1
4	579300-001	Screw-#2 X 3/16 drive-SST	2
5	410907-001	Protector-conduit plug	1

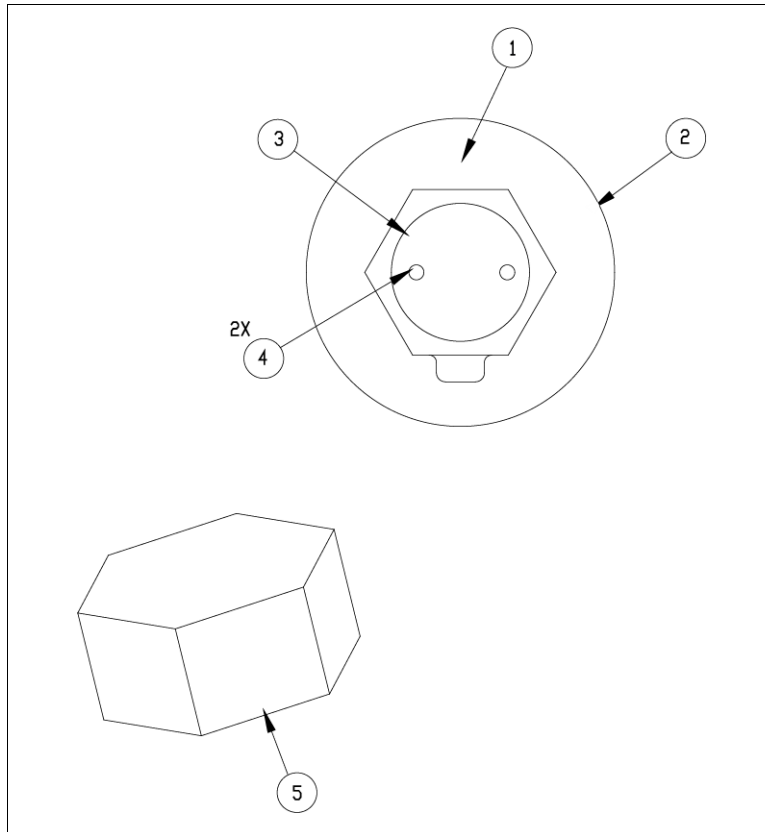

Figure 65. RA Conduit Box Plug Kit

Eyebolt Plug Kit Parts

Table 20 lists the 410482-001 Eyebolt Plug Kit parts list.

Table 20. 410482-001 Eyebolt Plug Kit Parts List

Item (ref. Figure 66)	Part No.	Description	Qty.
1	410118-001	Plug-lifting eyebolt-mach-painted	1
2	410118-001	Eyebolt-lifting	1
3	072-720-1	O-ring-928-FKM (conduit box plugs)	1
4	410126-001	Nameplate-lifting plug	1
5	026-236-1	Screw-#2 X 3/16 drive	2

Table 21 lists the 410482-002 RA Eyebolt Plug Kit parts list.

Table 21. 410482-002 RA Eyebolt Plug Kit Parts List

Item (ref. Figure 66)	Part No.	Description	Qty.
1	410118-002	Plug-lifting eyebolt-mach-coated	1
2	410844-001	Eyebolt-0.500-13-stainless steel	1
3	072-720-1	O-ring-928-FMK (conduit box plugs)	1
4	410126-005	Nameplate-lifting plug-Red Armor™	1
5	579300-001	Drive screw-#2 X 0.188 LG-SST	2
6	410907-001	Protector-conduit plug	1

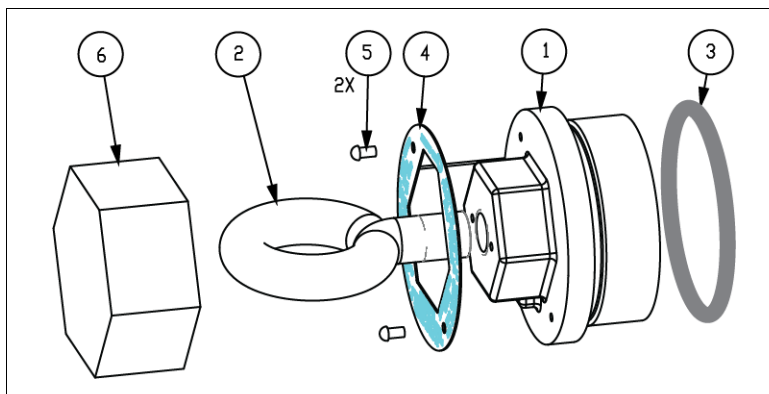

Figure 66. Eyebolt Plug Kit

Siphon Dummy Plug Kit Parts

Table 20 lists the 410483-001 AG Siphon Dummy Plug Kit parts list.

Table 22. 410483-001 AG Siphon Dummy Plug Kit Parts List

Item (ref. Figure 67)	Part No.	Description	Qty.
1	410081-001	Port plug - siphon	1
2	579005-004	O-ring 0.813 I.D. x 0.09 W (-117) - FKM	1
3	579005-005	O-ring 1.063 I.D. x 0.09 W (-121) - FKM	1

Table 21 lists the 410483-002 RA Siphon Dummy Plug Kit parts list.

Table 23. 410483-002 RA Siphon Dummy Plug Kit Parts List

Item (ref. Figure 67)	Part No.	Description	Qty.
1	410081-002	Port plug - siphon	1
2	579005-004	O-ring 0.813 I.D. x 0.09 W (-117) - FKM	1
3	579005-005	O-ring 1.063 I.D. x 0.09 W (-121) - FKM	1

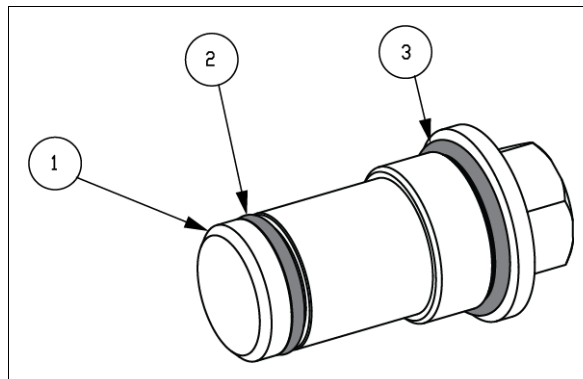

Figure 67. Siphon Dummy Plug Kit

Manifold Installation Tool Kit

Table 24 lists the 410912-001 Manifold Installation Tool Kit parts list.

Table 24. 410912-001 Manifold Installation Tool Kit Parts List

Item (ref. Figure 68)	Part No.	Description	Qty.
1	410890-001	ASM - Manifold install tool	1

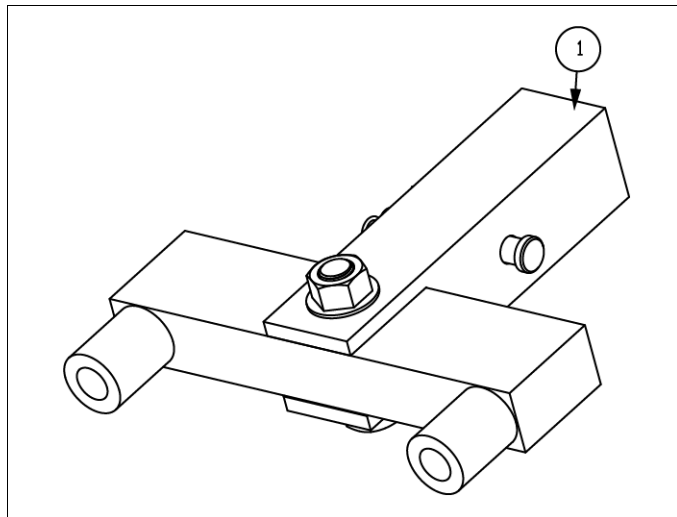

Figure 68. Manifold Installation Tool Kit

RA Touch-Up Paint Kit

Table 25 lists the 410913-001 RA Touch-Up Paint Kit parts list.

Table 25. 410913-001 RA Touch-Up Paint Kit Parts List

Item (ref. Figure 69)	Part No.	Description	Qty.
1	410910-001	Paint - touch up - Red Armor™	1

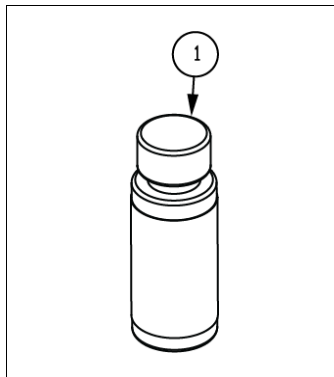

Figure 69. RA Touch-Up Paint Kit

Powder Coat Protector Kit

Table 25 lists the 410911-001 Powder Coat Protector Kit parts list.

Table 26. 410911-001 Powder Coat Protector Kit Parts List

Item (ref. Figure 70)	Part No.	Description	Qty.
1	410907-001	Protector - conduit plug	1
2	410908-001	Protector - check valve	1
3	410909-001	Protector - MLD plug	1

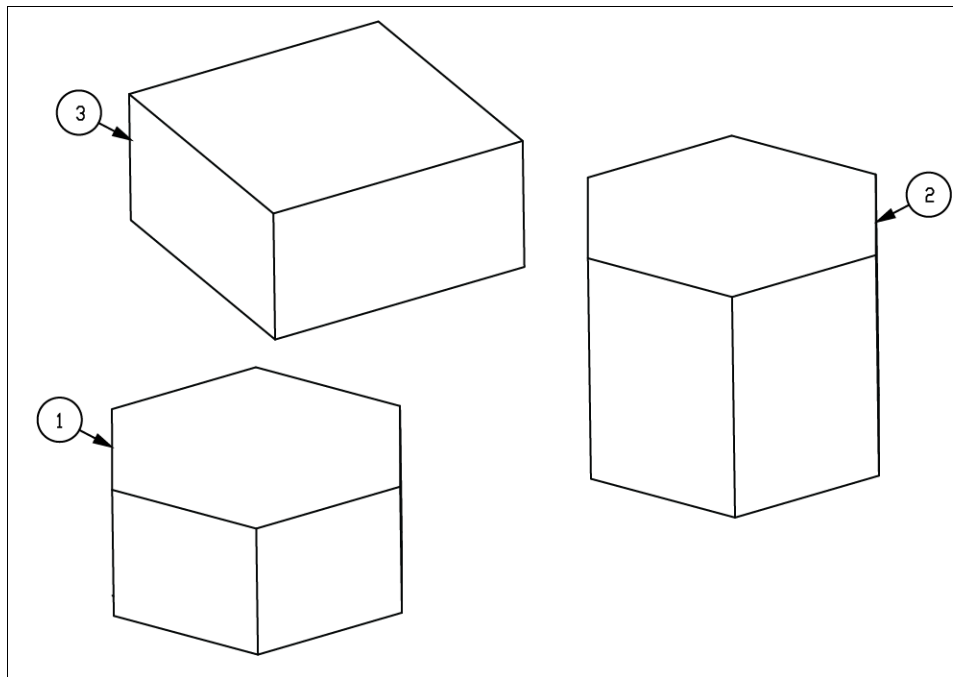

Figure 70. Powder Coat Protector Kit

Conduit Bushing Kit Parts

Table 27 lists the 410486-001 Conduit Bushing Kit parts list.

Table 27. 410486-001 Conduit Bushing Kit Part List

Item (ref. Figure 71)	Part No.	Description	Qty.
1	410301-001	Bushing - Conduit	1

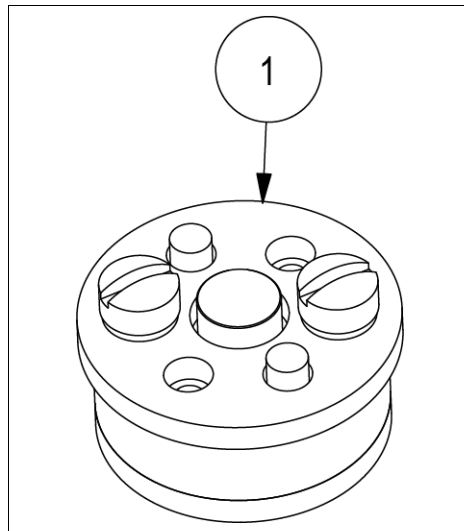

Figure 71. Conduit Bushing

O-Ring Kit Parts

Table 28 lists the 410154-001 O-ring Kit parts list.

Table 28. 410154-001 O-Ring Kit Parts List

(Ref. Figure)	Part No.	Description	Qty.
Figure 42 on page 47	072-541-1	O-ring - 118-FKM	1
Figure 44 on page 50	072-578-1	O-ring - 225-FKM	1
Figure 44 on page 50	072-685-1	O-ring - 114-FKM	2
Figure 42 on page 47	072-686-1	O-ring - 228-FKM	1
Figure 42 on page 47	072-720-1	O-ring - 928-FKM	3
Figure 42 on page 47	579005-001	O-ring - 343-FKM	1
Figure 42 on page 47	579005-002	O-ring - 344-FKM	1
Figure 42 on page 47	579005-003	O-ring - 345-FKM	1
Figure 35 on page 37	579005-004	O-ring - 117-FKM	2
Figure 35 on page 37	579005-005	O-ring - 121-FKM	4
Figure 44 on page 50	579005-006	O-ring - 231-FKM	1
Figure 55 on page 62	579005-007	O-ring - 014-FKM	1
Figure 55 on page 62	579005-009	O-ring - 903-FKM	1
Figure 7 on page 15, Figure 41 on page 45, and Figure 55 on page 62	072-690-1	O-ring - 015-FKM	2
Figure 39 on page 44	410127-001	Nut - flanged - M12x1.75-6H NOTICE For RA applications, discard the enclosed nuts and use the nuts supplied with the 410906-001 RA Die Spring kit.	2
Figure 53 on page 61	579014-002	Hitch pin	1
Appendix A	577013-835	O-ring gauge	1

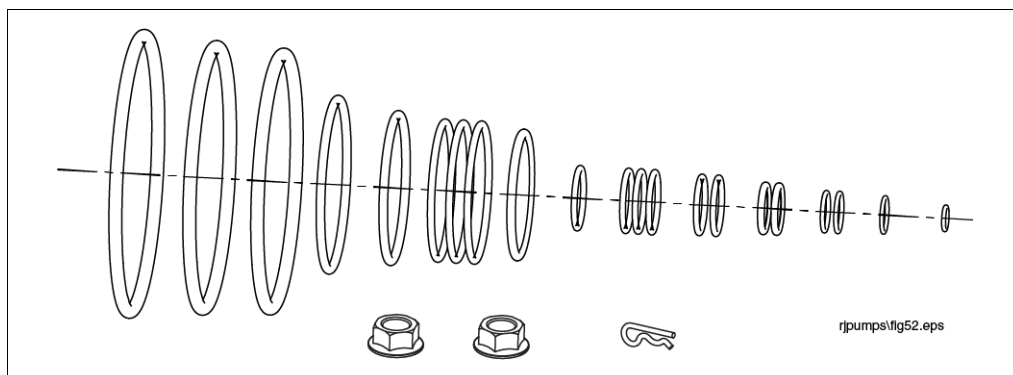

Figure 72. O-Ring Kit

Capacitor Kits

Table 29 lists the Capacitor Kit parts list.

Table 29. Capacitor Kits

Item (ref. Figure 73)	Part No.	Description	Qty.
1	410164-001	17.5 μ F Capacitor	1
1	410164-002	25 μ F Capacitor	1
1	410164-003	40 μ F Capacitor	1

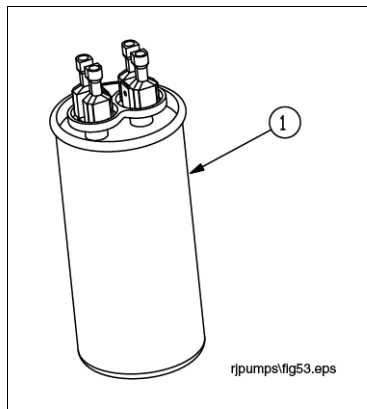

Figure 73. Capacitor Kit

Electrical Connector Kit Parts

Table 30 lists the 410165-001 Electrical Connector Kit parts list.

Table 30. 410165-001 Electrical Connector Kit Parts List

Item (ref. Figure 74)	Part No.	Description	Qty.
1	113-640-4	Connector - male	1
2	410117-001	Connector - electrical	1
3	072-541-1	O-ring - 118 - FKM	1
4	072-214-1	Ring - internal lock - 5/8" ID x 7/8" OD	1

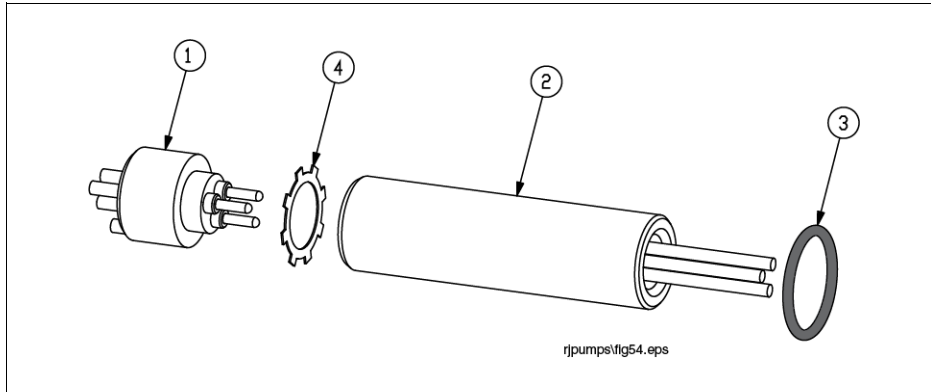

Figure 74. Electrical Connector Kit

Control Boxes

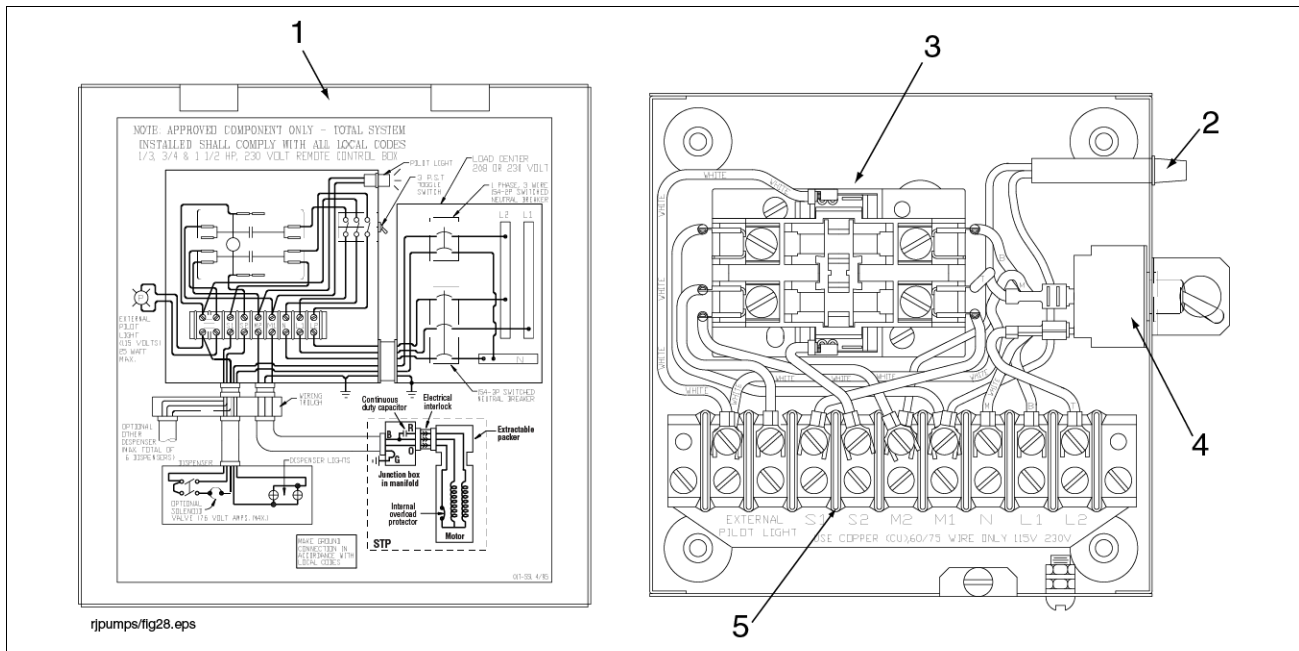

Figure 75. 880-041-5/880-042-5 Control Box

Table 31. 880-041-5 Control Box W/115V Coil (60 Hz)

Item (Ref. Figure 75)	Part No.	Description	Qty.
1	108-572-4	Control box	1
2	147-006-1	Pilot light ass'y	1

Table 31. 880-041-5 Control Box W/115V Coil (60 Hz)

Item (Ref. Figure 75)	Part No.	Description	Qty.
3	014-723-1	Line contractor relay	1
4	080-858-1	Toggle switch	1
5	008-202-1	Terminal block	1

Table 32. 880-042-5 Control Box W/230V Coil (50/60 Hz)

Item (Ref. Figure 75)	Part No.	Description	Qty.
1	108-572-4	Control box	1
2	147-006-1	Pilot light ass'y	1
3	014-720-1	Line contractor relay	1
4	080-858-1	Toggle switch	1
5	008-202-1	Terminal block	1

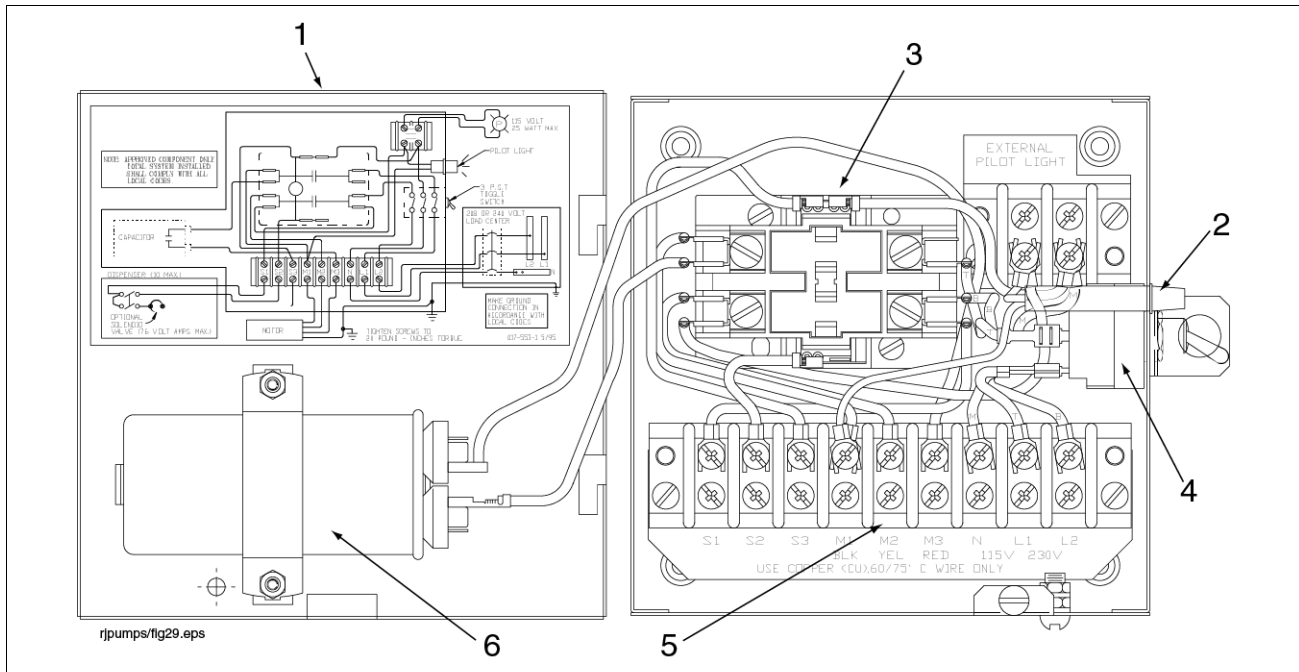

Figure 76. 880-045-5/880-046-5 Control Box

Table 33. 880-045-5 1/3 And 3/4 HP Control Box W/Cap (115V Coil)

Item (Ref. Figure 76)	Part No.	Description	Qty.
1	123-141-1	Control box	1
2	147-006-1	Pilot light ass'y	1
3	014-723-1	Line contractor relay	1
4	080-858-1	Toggle switch	1
5	008-202-1	Terminal block	1
6	111-092-5	Capacitor	1

Table 34. 880-046-5 All 1-1/2 HP Control Box W/Cap (115V Coil)

Item (Ref. Figure 76)	Part No.	Description	Qty.
1	123-141-1	Control box	1
2	147-006-1	Pilot light ass'y	1
3	014-723-1	Line contractor relay	1
4	080-858-1	Toggle switch	1
5	008-202-1	Terminal block	1
6	111-661-5	Capacitor	1

Appendix A: Hardware/Seal Kit O-Ring Gauge

The Red Jacket Pump O-Ring Gauge

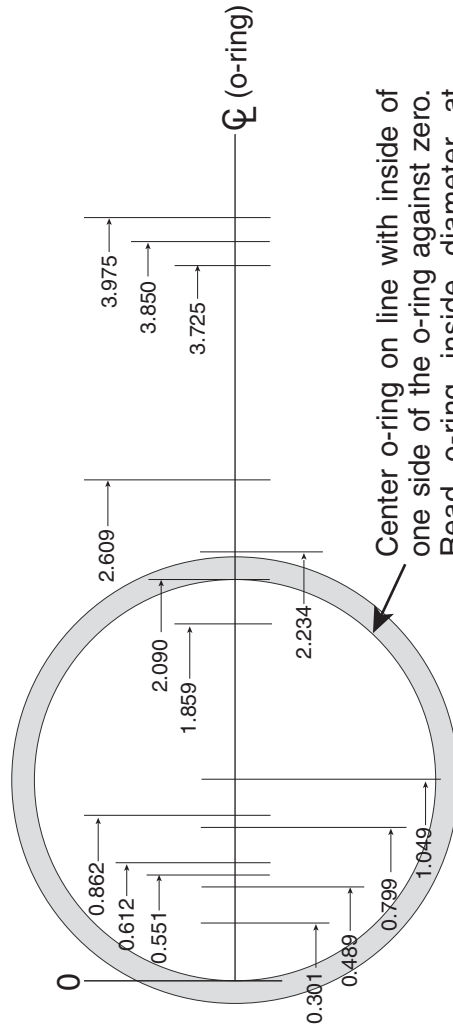
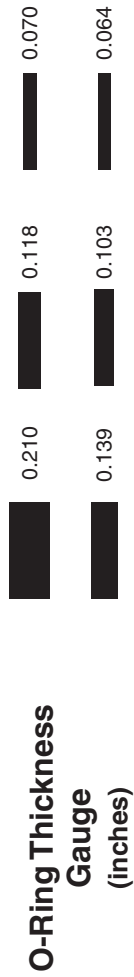

Center o-ring on line with inside of one side of the o-ring against zero. Read o-ring inside diameter at inside of the opposite side. The example is 2.090 inches inside diameter.



Part No. 577013-835, Rev. A

Appendix B: Check Valve/Air Purge Screw Operation

This appendix discusses the theory of operation of the Red Jacket STP's check valve and air purge screw.

Check Valve Operation

Pump On

As shown in the check valve cutaway diagram in Figure B-1, when the pump is On, the check valve is opened by fuel flow.

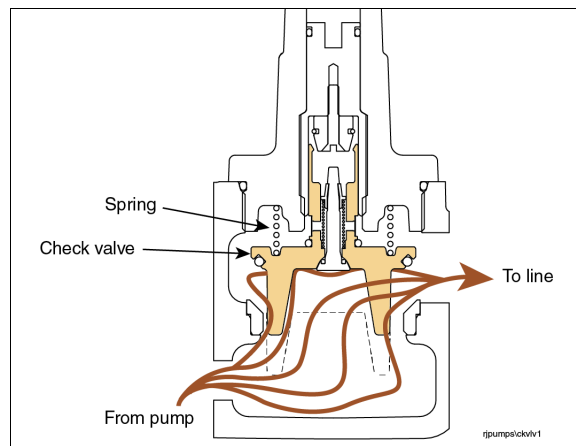

Figure B-1. Pump On Condition

Pump Off

When the pump shuts off, the check valve reseats isolating the line. As pressure in the line builds due to thermal expansion, the excess pressure vents through the relief valve back into the tank as shown in Figure B-2.

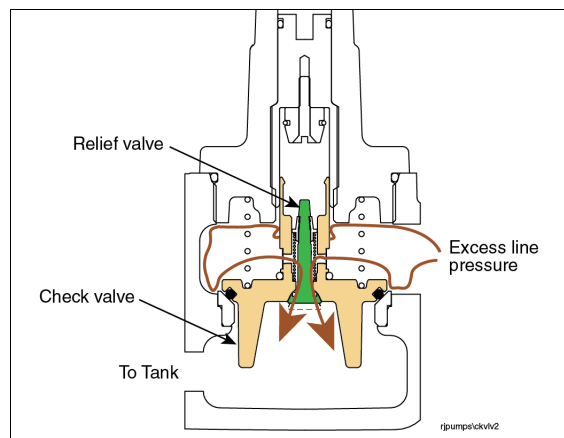

Figure B-2. Relief Valve Vents Excess Line Pressure

Locking Down Check Valve for Line Testing

Turning the service screw all the way clockwise, seals the relief valve and at the same time locks down and seals the check valve as shown in Figure B-3. The line is now isolated for pressure testing.

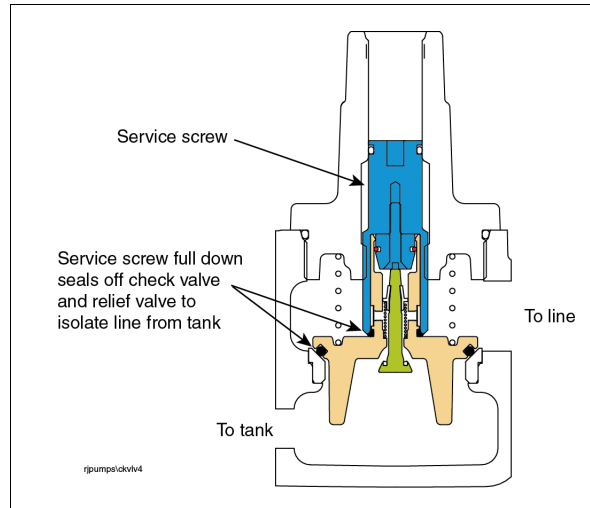

Figure B-3. Locking Down The Check Valve For Line Testing

Removing Check Valve

When removal of the check valve is desired, turn the service screw clockwise until it is all the way down as shown in Figure B-4. At about 7.5 clockwise turns, the relief valve will open (you will hear line pressure vent) and the service screw will lock onto the check valve. When you have turned the service screw all the way down, back off 3 or 4 turns (counterclockwise) and wait a few seconds for the product in the manifold to drain out. Unscrew the check valve housing and remove the complete valve assembly.

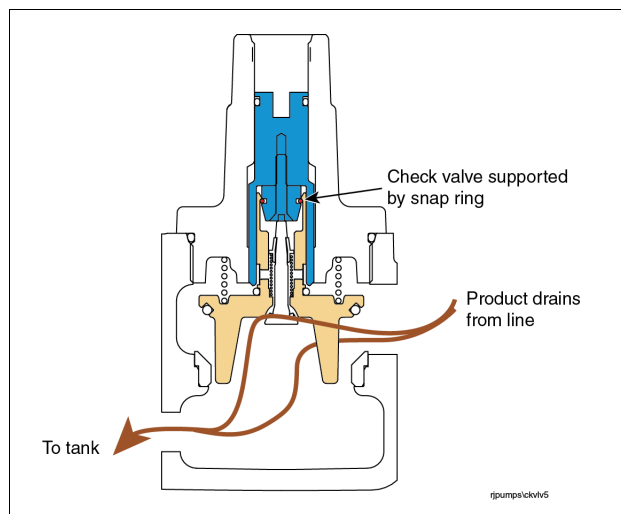

Figure B-4. Removal Of Check Valve Assembly For Service

How the Service Screw Lifts the Check Valve

When you turn the service screw clockwise 7.5 turns to push open the relief valve stem, a slightly compressible snap ring in the service screw squeezes past a rim on the inside of the top edge of the check valve as shown in Figure B-5. As the service screw is turned counterclockwise, the snap ring rises beneath the rim lifting the check valve. The check valve continues to rise as the service screw is turned ccw until the outer edge of the check valve contacts the bottom surface of the check valve housing (when you are unscrewing the service screw you will feel this 'stop'). Continuing to turn the service screw until it is all the way up, compresses the snap ring until it is past the rim to a degree that the spring in the check valve (and gravity) forces the check down onto its seat in the manifold. All the way up is the normal operating position of the service screw.

Always make sure to reinstall the plastic protective cap and fully thread it into place to ensure a good seal.

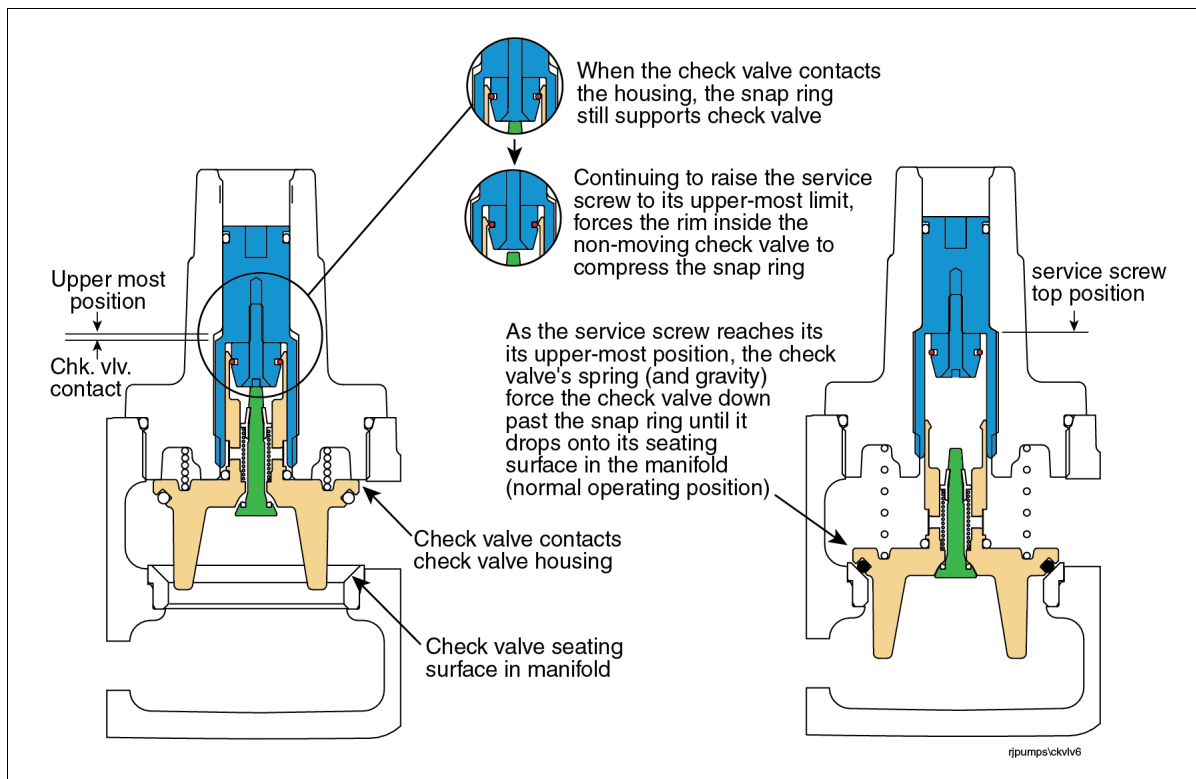

Figure B-5. Returning the Check Valve To Its Normal Operating Position

Air Purge Screw Operation

The air purge screw is used to rid air from the line and manifold hydraulic cavities after opening a port in the manifold (e.g., after installing a line leak detector). When repairs to the pump have been made, the technician will need to purge the air within the manifold as shown in diagram 1 of Figure B-6. The air purge screw is rotated 2-3 turns counterclockwise, then the pump is turned on.

⚠WARNING The air purge screw is retained by the hitch pin to limit travel. Do not attempt to rotate beyond 3 turns.

As the pump runs, any air in the cavities is pushed through the small tank return port as shown in diagram 2. After the pump has run for about 2-3 minutes the air will have been removed from the manifold and piping as shown in diagram 3. While the pump is still running, turn the air purge screw clockwise until it is completely closed. Open the ball valve down line from the pump.

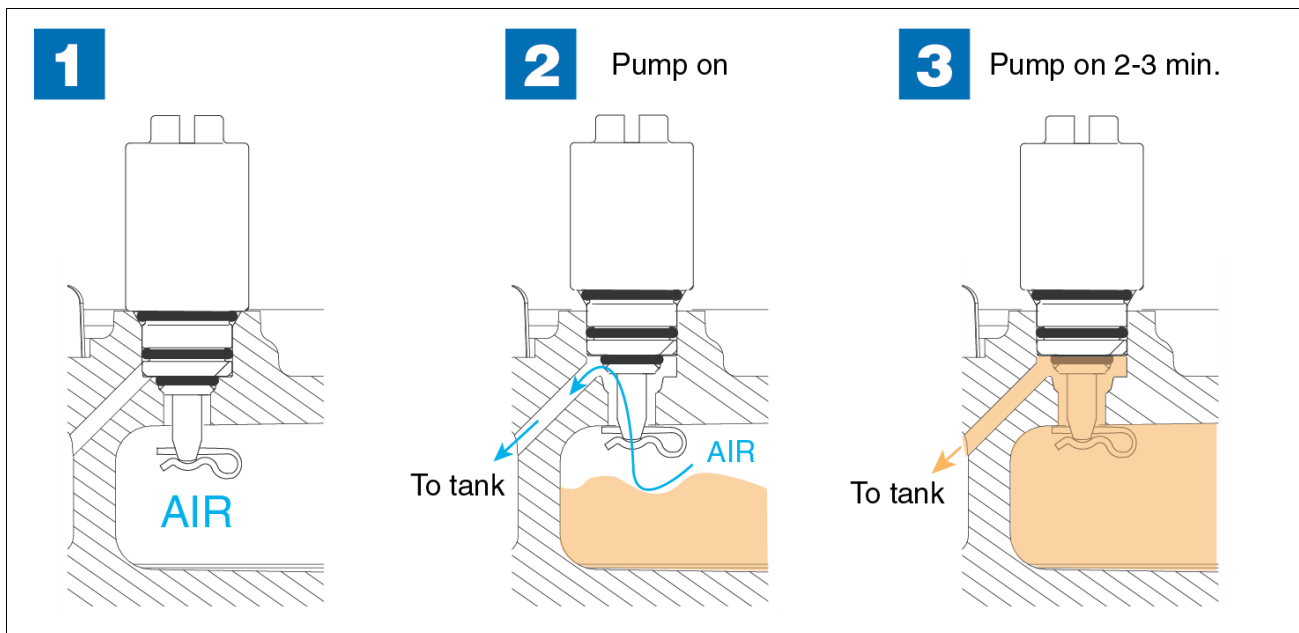

Figure B-6. Purging Air From Manifold

Appendix C:

ANZEx CONDITIONS OF CERTIFICATION:

1. It is a condition of manufacture that each motor be subjected to the routine high voltage test of clause 6.2 of AS2380.1.
2. It is a condition of safe use that all submerged turbine pumps, manifolds and associated equipment be installed in accordance with the manufacturer's Installation, Operation and Service Manuals supplied.
3. It is a condition of safe use that all installations must provide reliable electrical connection between the pump motor, frame, pipe, manifold or junction box and the tank structure for both electrical protection and equipotential bonding.
4. It is a condition of safe use that, where terminal boxes are used for termination of the cables from the motor and the supply source, they shall be Australian certified for use in Gas Group IIA and Zone I hazardous areas.
5. It is a condition of safe use that where a differential pressure switch or transducer is installed, each must be capable of ensuring that the nominated temperature classification is not exceeded.

Appendix D

The City of New York Fire Department Conditions of Approval Certificate of Approval #5052

1. Motor wiring shall be in accordance with the New York City Electrical code for hazardous locations.
2. The installation and use of pumps shall comply with applicable New York City Code, rules and regulations including 3RCNY § 21-20 and/or 3RCNY § 21-21. Manufacturer's and Underwriters Laboratories Inc.'s safety requirements and limitations shall be complied with.
3. Pumps shall be Underwriters Laboratories Inc. listed and pump manufacturer shall retain follow up service requirements of Underwriters Laboratories Inc.
4. Equipment shall have secured and shall maintain all required approvals and shall meet all applicable Federal and State requirements. The use of this product shall be limited to the indicated intent and has not been acceptable for other uses or applications.
5. Certificate of Approval number shall be plainly and permanently stamped or otherwise fixed upon each pump by the manufacturer.
6. The Certificate of Approval is issued upon condition that the material or equipment's technology does not violate any patent, trade name, trade secret or other intellectual right.
7. The Fire Department Certificate of Approval does not constitute an endorsement or recommendation of your product by the Fire Department, but is a certification that your product, as represented, meets the standards as of the date of issuance.
8. The Fire Department's conditions of approval shall be enumerated in the installation manuals and brochures that will be provided to New York City buyers, users and installers.
9. The Fire Department reserves the right to withdraw this approval at any time in the event there is a reasonable doubt that the product does not operate or perform as required by code, the conditions of this resolution or as represented in your application.
10. As the manufacturer of this equipment/material, you should be aware that any end user who fails to comply with the condition as outlined in the approval will be subject to enforcement action which may include fines and imprisonment.

Pursuant to §15-220.1 of the New York City Administrative Code, any person who shall knowingly make a false statement or who shall knowingly falsify or allow to be falsified any Certificate of Approval application shall be punished by a fine of not less than one thousand dollars (\$1,000.00) and not more than five thousand dollars (\$5,000.00) or by imprisonment not to exceed six months, or both, for each such offense.

Appendix E: CNEx Conditions of Certification

4” The Red Jacket Single-Phase STP Safety Instructions - CNEx SPECIAL CONDITIONS FOR SAFE USE

- The Single-Phase Red Jacket Submersible Turbine Pump Assemblies have China certification under CCC Certificate Number 2021312302000034 and shall be marked with the following information:

Manufacturer:

Veeder-Root Company
2709 Route 764
Duncansville, PA 16635 U.S.A.

Marking:

Type Series
Serial Number
Year of Construction



Ex db IIA T4 Gb
IECEX UL 20.0103X
CAUTION-KEEP COVERS TIGHT WHILE CIRCUITS ARE ALIVE

Instructions:

- All submerged turbine pumps, manifolds and associated equipment shall be installed in accordance with the manufacturer’s installation, operation and service manuals supplied.
- All submerged turbine pumps can only be mounted and used in the vertical, upright position.
- All installations shall provide reliable electrical connection between the pump/motor, frame, pipe, manifold or junction box and the tank structure for the electrical protection and equipotential bonding.
- The minimum fuel level shall be set at least 30mm above the highest product intake level at the bottom of the pump motor.
- Where terminal boxes are used for termination of the cables from the motor and the supply source, they shall be certified for use in gas group IIA and Category 2 by the appropriate Notified Body.
- Where a differential pressure switch or transducer is installed, each must be capable of ensuring that the marked temperature classification is not exceeded.
- Fasteners securing the discharge head are non-metric. They shall be replaced only by fasteners provided in kit 144-327-4 and kit 410818-001 for models with the AG prefix.
- The flameproof dimensions are detailed in certification drawing number 410789-001 and shall not be repaired.
- Compliance with the International Electrotechnical Commission IECEx has been assured by compliance with IEC 60079-0 Ed. 7.0 and IEC 60079-1 Ed. 7.0.

