

# Clamp Fittings and Accessories Product Specification

## Overview

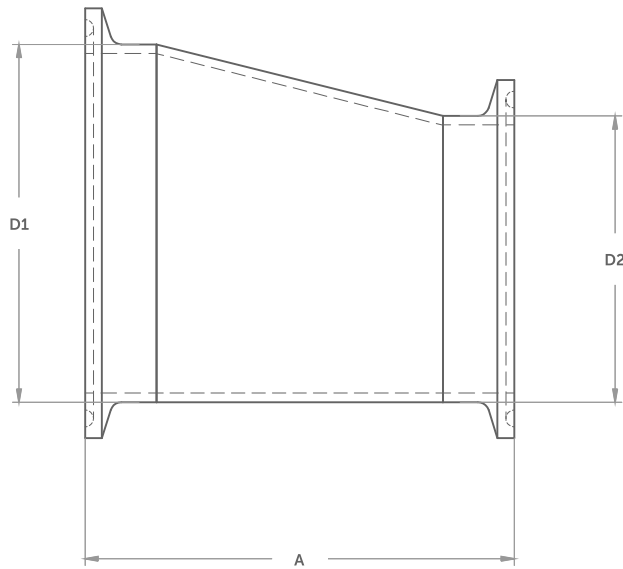

- Ferrules on both ends
- Height to diameter ratio varies across sizes

## CLAMPED ECCENTRIC REDUCER - 32MP



Product Code		WT		D1		D2		Dim A		Weight Per Unit		Carton Quantity
304	316	mm	inches	mm	inches	mm	inches	mm	inches	kg	lbs	
201064CER	201066CER	1.6	0.065	50.8	2.000	25.4	1.000	127.0	5.000	0.27	0.59	45
201564CER	201566CER	1.6	0.065	50.8	2.000	38.1	1.500	76.2	3.000	0.20	0.43	50
252064CER	252066CER	1.6	0.065	63.5	2.500	50.8	2.000	76.2	3.000	0.25	0.55	40
302064CER	302066CER	1.6	0.065	76.2	3.000	50.8	2.000	127.0	5.000	0.43	0.94	30
302564CER	302566CER	1.6	0.065	76.2	3.000	63.5	2.500	76.2	3.000	0.32	0.71	30
402064CER	402066CER	1.6	0.065	101.6	4.000	50.8	2.000	231.7	9.125	0.95	2.09	12
402564CER	402566CER	1.6	0.065	101.6	4.000	63.5	2.500	180.9	7.125	0.86	1.89	12
403064CER	403066CER	1.6	0.065	101.6	4.000	76.2	3.000	130.1	5.125	0.69	1.52	12

## TOLERANCES

Dim A  $\pm 1.25\text{mm}$