

SuperKlean Washdown Products

February 2012

DURAMIX 8000

INSTALLATION AND MAINTENANCE INSTRUCTIONS

****DO NOT THROW AWAY AFTER INSTALLATION****

****SAVE AND DISPLAY PROMINENTLY WHERE THIS EQUIPMENT IS USED****

WARNING

HIGH PRESSURE AND HOT LIQUID SPRAYS CAN CAUSE SERIOUS BODILY INJURY.

CAUTION: THIS UNIT IS DESIGNED FOR SATURATED STEAM ONLY. IMPROPER USE, INSTALLATION OR MAINTENANCE CAN RESULT IN SERIOUS INJURY.

INSTALLATION AND MAINTENANCE SHOULD ONLY BE DONE BY A QUALIFIED PROFESSIONAL. SUPERKLEAN IS NOT LIABLE FOR ANY INJURY THAT IS A RESULT OF IMPROPER USE, INSTALLATION OR MAINTENANCE.

<p>NEVER</p>	<ul style="list-style-type: none">• Never allow children or unauthorized personnel to handle equipment.• Never put your hand or fingers in front of nozzle.• Never point nozzle at your body — or anyone else.• Never leave wash down station unattended without releasing pressure.• Never use foreign means to hold trigger in open position.• Never over tighten connections/threads. Use appropriate size wrench for tightening connections/threads. Never use wrench extensions of any type.• Never pulse nozzle while operating mixing station.
<p>BEFORE nozzle spraying and during nozzle spraying ALWAYS</p>	<ul style="list-style-type: none">• Before pulling trigger hold nozzle firmly.• Adopt a proper body stance to anticipate high recoil force by spray nozzle.• Exercise care and caution when spraying.• When spraying hot liquids avoid hand or body contact with non-insulated parts of the nozzle.• Wear protective clothing including heavy-duty insulated gloves, boots, aprons and safety glasses.• Stop spraying before becoming fatigued.
<p>BEFORE removing nozzle — OR — attempting service or maintenance ALWAYS</p>	<ul style="list-style-type: none">• Shut off steam and water supplies.• Discharge contents of hose and nozzle to eliminate pressure.

- Follow the manufacturer's recommendations for maximum pressures, periodic cleaning, maintenance and parts replacement procedures.
- Do not operate the equipment if there are any leaks from spray nozzle, fittings, or hoses. High pressure leaks can penetrate the skin causing serious injury.

STAY SAFE!

SuperKlean Washdown Products

PRE-INSTALLATION:

1. Unit requires minimum steam pressure of 30 PSI and a maximum steam pressure of 150 PSI. Pressure gauge installation (upstream, prior to steam inlet) is recommended to determine proper and constant steam pressure during all operation of mixing unit.
2. Unit requires minimum water pressure of 30 PSI, a recommended water pressure of 80 PSI, and a maximum water pressure of 150 PSI. Pressure gauge installation (upstream, prior to water inlet) is recommended to determine proper and constant water pressure during all operation of mixing unit.
3. Steam trap is highly recommended (upstream, prior to steam inlet) to relieve unit of any condensate.
4. Steam and water supply lines should be thoroughly flushed prior to installation to rid lines of foreign debris which can affect the performance of the mixing unit.
5. Remove steam check valve from mixing body by loosening check valve nut.
6. Make sure that there is no water in steam chamber by turning mixing unit upside down and letting it drain.
7. Reinstall steam check valve and tighten check valve nut.
8. Check to make sure that both globe valves are fully closed by turning hand-wheels clockwise.
9. Check to make sure that the temperature control hand wheel is fully opened by turning it counter-clockwise.
10. Mixing unit is ready to install.

INSTALLATION:

1. Place the mounting plate on the wall and mark the 4 holes to be used to mount the plate to the wall.
2. Drill 12mm or equivalent holes on wall and install anchor bolts (supplied). Make sure that holes are deep enough to accommodate anchor bolts so that they do not stick out too much and interfere with the mounting of the mixing unit.
3. Mount plate to wall and secure using anchor bolt nuts (supplied).
4. Mount mixing unit to plate and loosely secure with two top bolts (supplied).
5. Mount hose rack to mixing unit and secure with 2 bottom bolts (supplied).
6. Secure unit to mounting plate by tightening all 4 supporting bolts.
7. If temperature gauge was supplied, remove front plug and install temperature gauge. (Pipe thread sealant or alternative such as Teflon tape is recommended on temperature gauge thread)
8. The mixing unit is now ready for piping.
9. Install water and steam supply lines to mixing unit inlets. (Pipe thread sealant or alternative such as Teflon tape is recommended on piping thread)
10. If secondary upper hot water outlet is to be used, install line to mixing unit top secondary output outlet. (Pipe thread sealant or alternative such as Teflon tape is recommended on piping thread)
11. Attach hose to outlet of mixing unit. (Pipe thread sealant or alternative such as Teflon tape is recommended on fitting thread)
12. Attach spray nozzle to outlet of hose. (Pipe thread sealant or alternative such as Teflon tape is recommended on fitting thread)
13. Check and make sure that steam & cold water supply globe valves are turned off.
14. Gradually open cold water globe valve to pressurize mixing station and check for leaks. If there are visible leaks, immediately turn globe valve off, depressurize mixing unit by spraying nozzle.

SuperKlean Washdown Products

Disassemble and reseal leakage points. Once complete, reassemble and restart procedure to check for leaks. If no more leaks, continue. If leaks, repeat procedure.

15. Gradually open steam globe valve to pressurize mixing station and check for leaks. If there are visible leaks, immediately turn globe valve off, depressurize mixing unit by spraying nozzle, allow mixing unit to cool down prior to disassembly, and reseal leakage points. Once complete, reassemble and restart procedure to check for leaks. If no more leaks, continue. If leaks, repeat procedure.
16. With both globe valves fully open, unit is ready.

OPERATIVE INSTRUCTIONS: (If water pressure is higher than steam pressure, please refer to section 6 below. If steam to water ratio is more than 2:1, please refer to section 7 below.**)**

1. Open cold water globe valve to its full open position by turning hand wheel counter-clockwise.
2. Open steam globe valve to its full open position by turning hand wheel counter-clockwise.
3. When shutting down unit, steam globe valve should be shut down first by turning clockwise and then cold water globe valve can be shut down by turning clockwise. **DO NOT TURN OFF COLD WATER GLOBE VALVE BEFORE TURNING OFF STEAM GLOBE VALVE.**
4. Begin spray of water by pressing on lever of nozzle. Make sure to maintain spray during the course of adjustment of unit.
5. For temperature rise, begin to slowly close temperature control hand wheel by turning it clockwise. Once you reach your desired water temperature output, you may leave the temperature control hand wheel at its current position and use globe style valves above mixing unit to shut down operation. To resume operation, simply open globe style valves to their full open position.
6. If temperature output is too cold after full adjustment of temperature control hand wheel, begin to choke down water flow by slowly closing the cold water globe valve.
7. If temperature output is too hot after full adjustment of temperature control hand wheel, begin to choke down steam flow by slowly closing the steam globe valve. Once desired temperature is achieved, close top lock nut cap below hand wheel by turning clockwise (hand tight). Secure lock nut cap with lower lock nut by turning counter clockwise until tight.
8. If you close the cold water globe valve significantly and water temperature output is still sporadic, please check to see if you meet and maintain required water pressure.

MAINTENANCE PROCEDURES:

CAUTION: Check and make sure that steam & cold water supply globe valves are turned off prior to disassembly. Depressurize mixing unit by spraying nozzle and allow mixing unit to cool down prior to disassembly. Unit is now ready for maintenance.

*****Recommended Maintenance: Hard Water = Every 3 Months Soft Water = Every 6 Months*****

Water Chamber Cleaning:

1. Remove hand wheel nut, lock washer, and name plate from temperature control hand wheel located on the right side of the unit.
2. Gently tap hand wheel outward and then wiggle off by hand.
3. Remove water chamber cover plate with 2" socket or box end wrench.
4. Once water chamber plate is removed, stainless steel piston should slip out. Thoroughly clean piston from any debris prior to reassembly.

SuperKlean Washdown Products

5. While stainless steel piston is out of mixing unit body, thoroughly clean internal piston contact wall from any debris so that piston will be able to slide smoothly back inside.
6. Remove water chamber cover plate Teflon gasket.
7. Replace water chamber cover plate Teflon gasket.
8. Reverse instructions to reassemble.

*****Recommended only if experiencing significant steam leakage through mixing valve possibly caused by calcium deposits over an extended period of good service*****

Steam Poppet & Steam Poppet Seat Cleaning:

1. Remove steam chamber cover plate with 2" socket or open wrench.
2. With the steam chamber cover plate removed, the steam poppet will simply slide off. Once steam poppet is out use a fine brass wire brush to clean contact area on steam poppet. After thoroughly cleaning the steam poppet, make sure to also clean steam poppet seat inside steam chamber using brass wire brush. Once both areas have been thoroughly cleaned, re-insert steam poppet into its original position.
3. Using a small flat tip screwdriver, remove steam chamber cover plate Teflon gasket.
4. Replace steam chamber cover plate Teflon gasket.
5. Reverse instructions to reassemble. New steam chamber cover plate gasket should be used.
6. Once reassembled, test unit for leakage. If significant leakage is still visible, steam poppet and seat will have to be ground slightly between steam poppet and seat using valve grinding compound commonly found at auto parts stores.
7. Repeat removal instructions above until you have access to steam poppet.
8. Apply grinding compound onto steam poppet contact surface and reinsert into steam poppet seat and begin to slightly rotate contact surfaces with grinding compound in a circular manner while applying gentle pressure to steam poppet for approximately 1-2 minutes. As you grind, make sure to often "pick up", rotate a quarter turn, then place steam poppet back onto steam poppet seat and continue to grind as per above. Repeating this procedure will assure an even contact surface.
9. Clean contact surfaces completely of grinding compound and reassemble as per above instructions.

REPAIR INSTRUCTIONS:

CAUTION: Check and make sure that steam & cold water supply globe valves are turned off prior to disassembly. Depressurize mixing unit by spraying nozzle and allow mixing unit to cool down prior to disassembly. Unit is now ready for maintenance.

Check Valve Replacement:

1. Remove check valve connection nut.
2. Remove check valve from globe valve.
3. Reverse instructions to install new check valve.

Water Chamber Cover Plate Gaskets:

1. Remove hand wheel nut, lock washer, and name plate from temperature control hand wheel located on the right side of the unit.
2. Gently tap hand wheel outward and then wiggle off by hand.
3. Remove water chamber cover plate with 2" socket or box end wrench.
4. Remove water chamber cover plate Teflon gasket.

SuperKlean Washdown Products

5. Replace water chamber cover plate Teflon gasket.
6. Reverse instructions to reassemble.

Temperature Control Hand Wheel Stem Guide Filling:

1. Remove hand wheel nut, lock washer, and name plate from temperature control hand wheel located on the right side of the unit.
2. Gently tap hand wheel outward and then wiggle off by hand.
3. Remove water chamber cover plate with 2" socket or box end wrench.
4. Remove push down nut from stem guide and Teflon stem guide filling will be visible. This nut is on the exterior of the cover plate.
5. Turn temperature control hand wheel stem guide clockwise until you reach stopper.
6. Remove inside locking plug located on the inside of the cover plate using a crescent wrench.
7. Temperature control hand wheel stem can now be extracted through the inside by turning it clockwise.
8. Using a pick or equivalent, remove as much packing material as possible from the inside of the water chamber cover plate.
9. Reinsert the temperature control hand wheel stem by turning it counter-clockwise. Make sure to reinsert stem back through locking plug as when removed.
10. Begin to tighten locking plug inside water chamber cover plate. Please only hand tight.
11. Insert new Teflon filling into stem.
12. Insert push down nut into stem and begin to tighten. Please only hand tighten at this moment.
13. Reverse instructions to reassemble. New water chamber cover plate gasket should be used.
14. Once reassembled and reinstalled onto unit, operate unit as usual, if there is minimal leakage through stem packing, tighten push down nut slowly until leakage disappears.

Globe Valve Stem Guide Filling & Poppet:

1. Remove globe valve stem nut using crescent wrench or box end wrench by turning it counter-clockwise. Once completely loosened, entire stem will simply fall off along with globe valve poppet and stem nut gasket. Please note that globe valve poppet is "free floating" and thus will simply fall off its guide.
2. Remove hand wheel nut, lock washer, and name plate from globe valve hand wheel.
3. Gently tap hand wheel outward and then wiggle off by hand.
4. Remove hold down nut for stem using crescent wrench or box end wrench. If working on a steam globe valve, locking nut, cap and locking pin will have to be removed first.
5. On steam globe valve, remove push down nut from stem guide and Teflon stem guide filling will be visible.
6. On cold water globe valve, remove push down cap and push down sleeve from stem guide and Teflon stem guide filling will be visible.
7. Turn hand wheel stem guide clockwise until it can be extracted through the inside.
8. Using a pick or equivalent, remove as much packing material as possible from the inside of the globe valve.
9. Reinsert the hand wheel stem by turning it counter-clockwise.
10. Insert new Teflon filling into stem.
11. Insert push down nut into stem and begin to tighten. Please only hand tighten at this moment.
12. Insert new globe valve poppet and gasket on globe valve stem.

SuperKlean Washdown Products

13. Reverse instructions to reassemble.
14. Once reassembled and reinstalled onto unit, operate unit as usual, if there is minimal leakage through stem packing, tighten push down nut slowly until leakage disappears.

*****Do not open steam side chamber unless significant steam leakage is noticed.*****

Steam Chamber Cover Plate Gaskets:

1. Remove steam chamber cover plate with 2" socket or open wrench.
2. Using a small flat tip screwdriver, remove steam chamber cover plate Teflon gasket.
3. Replace steam chamber cover plate Teflon gasket.
4. Reverse instructions to reassemble.

Steam Poppet & Steam Poppet Seat Replacement:

10. To replace steam poppet, the steam chamber plate must be removed. Please follow instructions above for this procedure.
11. With the steam chamber cover plate removed, the steam poppet will simply slide off. Once steam poppet is out, unscrew poppet seat using a 1 1/16" socket. Reinstall new poppet seat along with new copper o-ring. Reinstall new steam poppet. (NOTE: Steam poppet is only sold with matching seat. Do not mix as seat is made to fit designated steam poppet. Minor pre-grinding may be necessary between steam poppet and seat using valve grinding compound commonly found at auto parts stores. Apply grinding compound onto steam poppet contact surface and reinsert into steam poppet seat and begin to slightly rotate contact surfaces with grinding compound in a circular manner while applying gentle pressure to steam poppet for approximately 1-2 minutes. As you grind, make sure to often "pick up", rotate a quarter turn, then place steam poppet back onto steam poppet seat and continue to grind as per above. Repeating this procedure will assure an even contact surface.
12. Clean contact surfaces completely of grinding compound.
13. Reverse instructions to reassemble. New steam chamber cover plate gasket should be used.
14. Apply air pressure to steam inlet and insert mixing unit outlet into bucket of water to check and see if continuous air bubbles can be observed. If continuous air bubbles are visible, repeat procedure.

SuperKlean Washdown Products

DURAMIX FRONT VIEW DRAWING

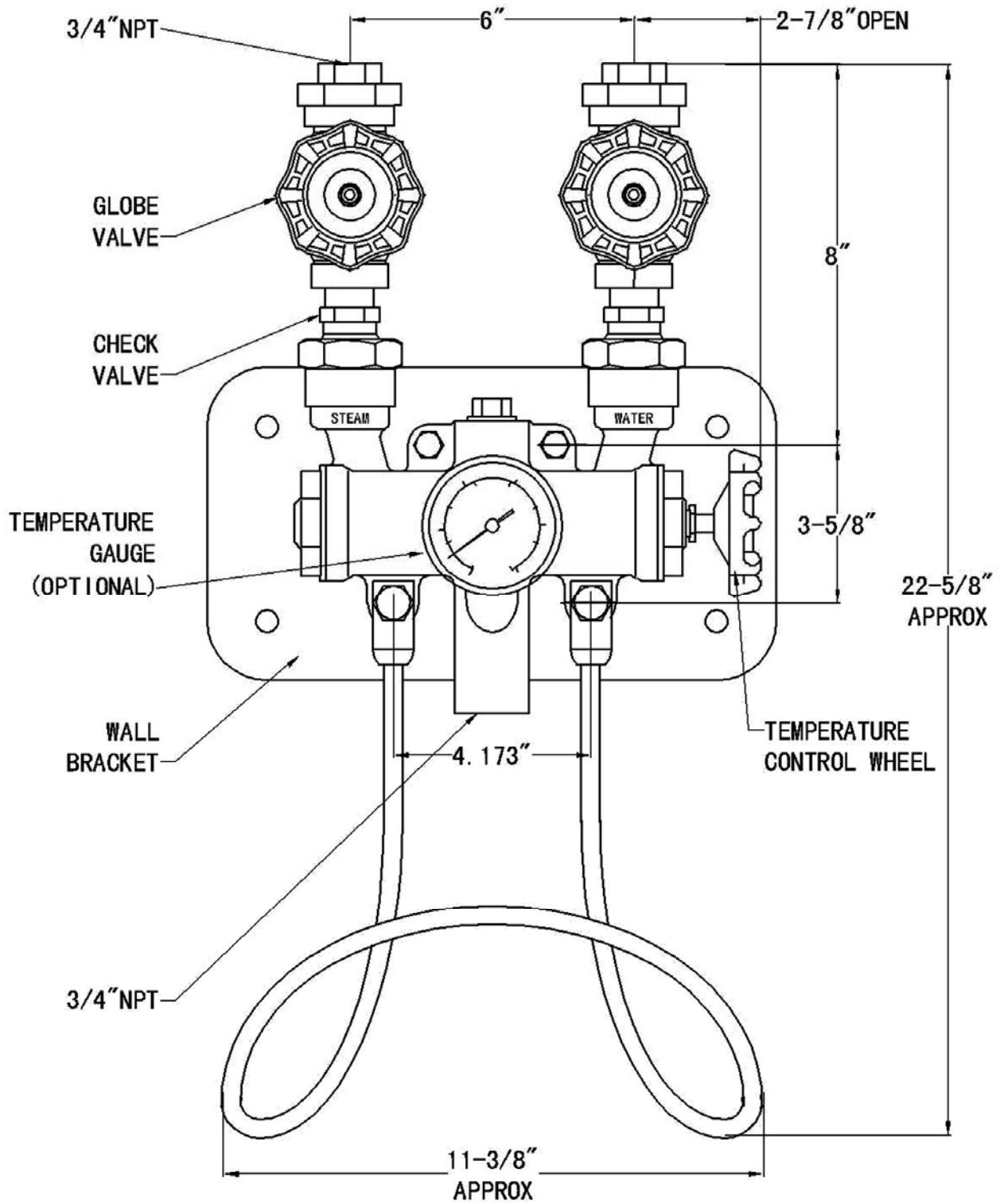

SuperKlean Washdown Products

DURAMIX SIDE VIEW DRAWING

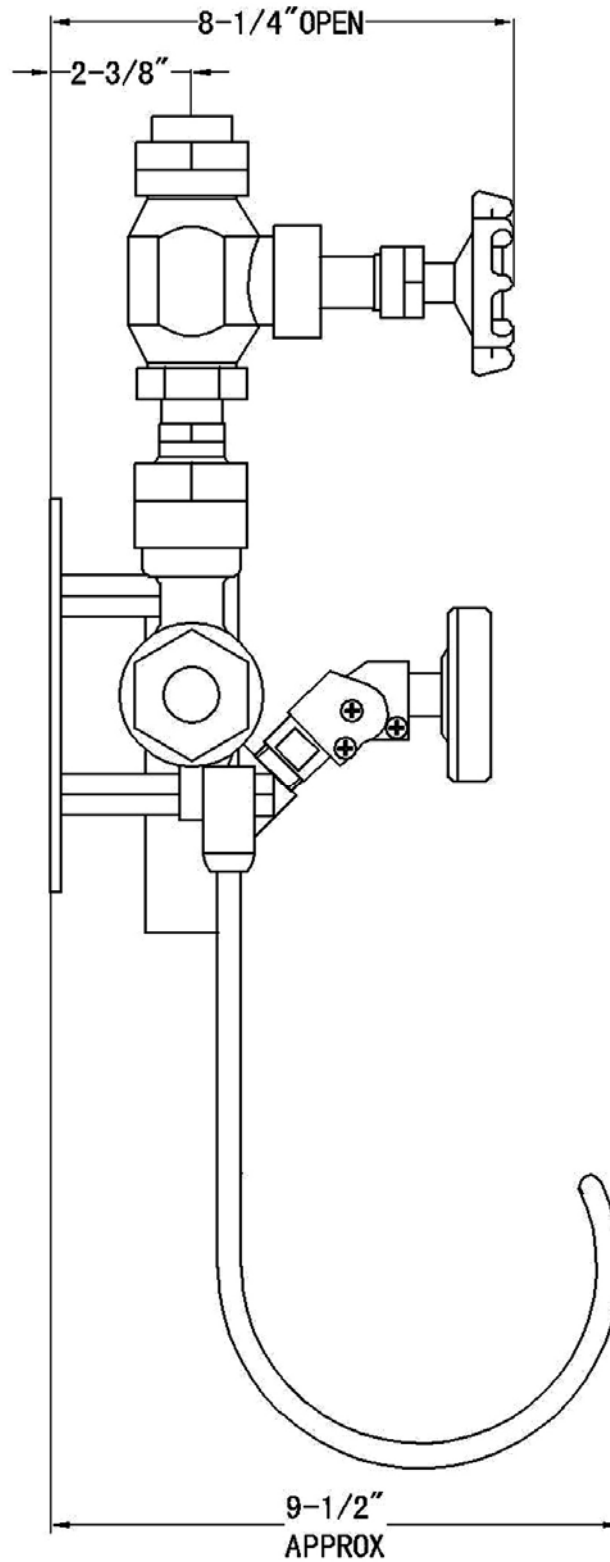

SuperKlean Washdown Products

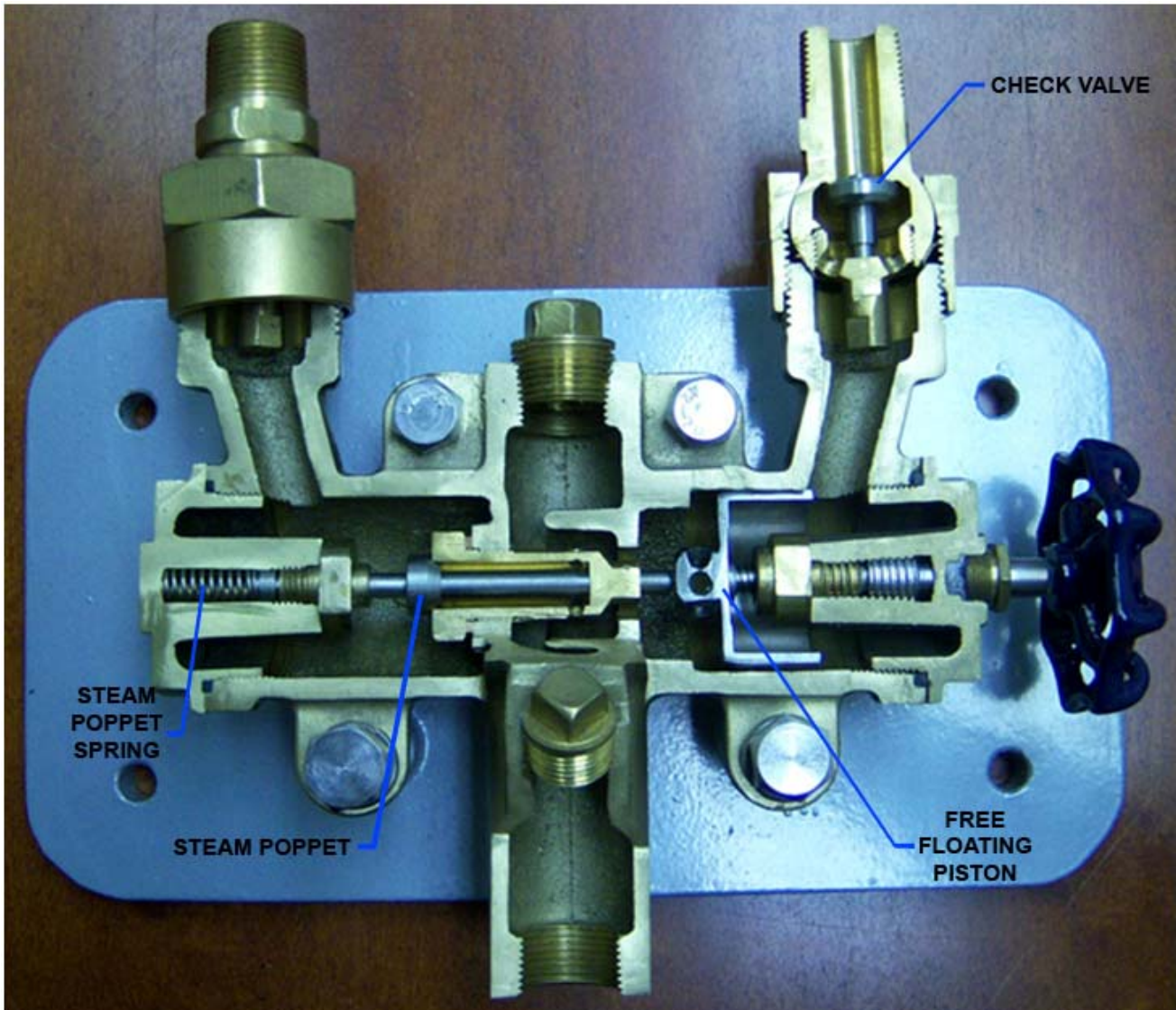

Automatic Shut Off Feature:

1. Water enters and passes through check valve. (Note: Water is not able to go back into water supply line because spring loaded check valve will only allow flow into unit)
2. With nozzle open, water pressure and flow allows the free floating piston to activate and opens steam poppet by pushing it towards the left side, thus allowing steam to mix with incoming water.
3. If there is an interruption of water pressure or water flow (such as shutting nozzle down), steam poppet spring pushes steam poppet back into its closed position within 5 seconds.

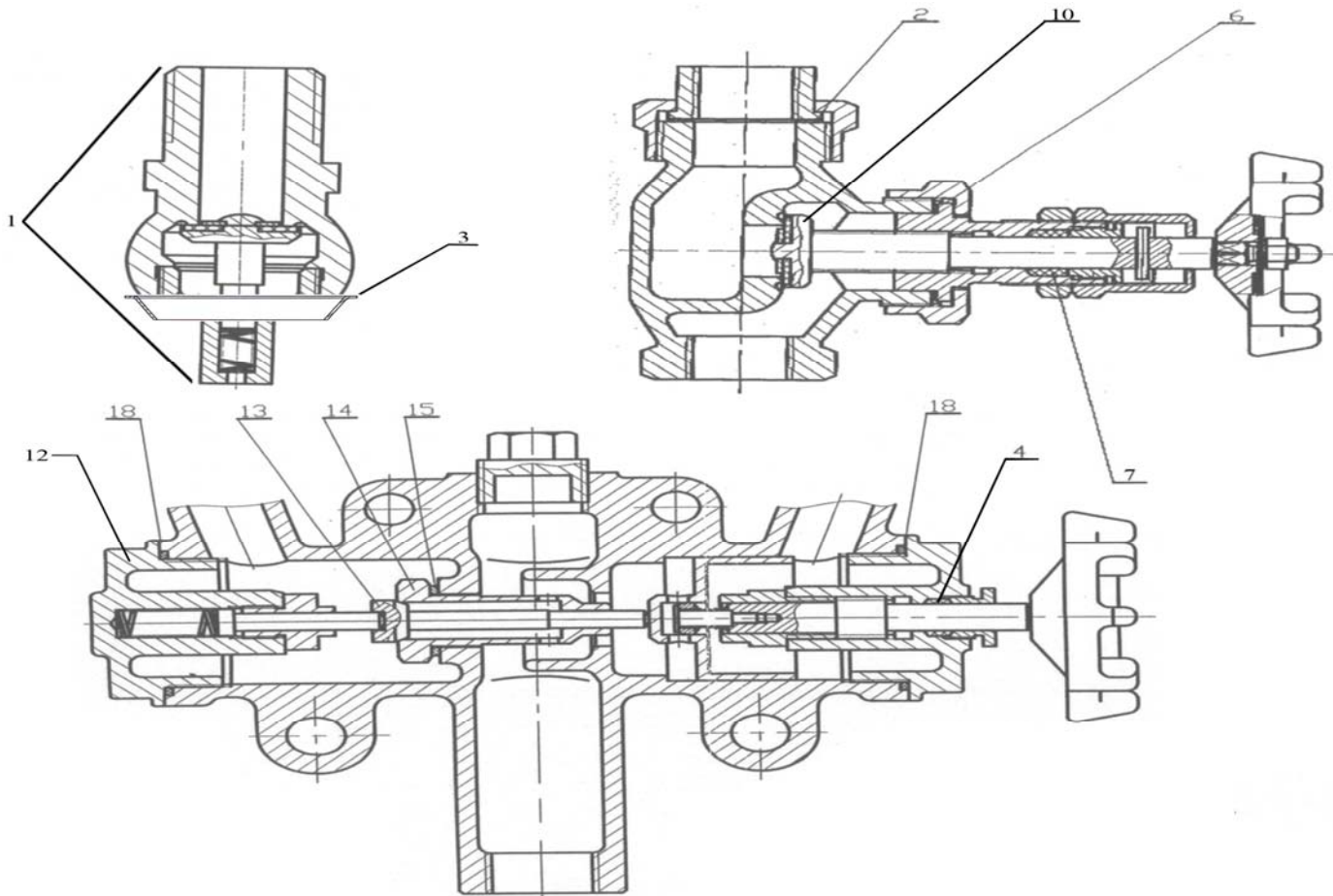

DURAMIX 8000 PARTS LIST

Part #:	Description:
DURA8-1B	Check valve assembly. Includes check valve poppet, spring, and Teflon coated copper connection gasket. Bronze.
DURA8-1S	Check valve assembly. Includes check valve poppet, spring, and Teflon coated copper connection gasket. Stainless steel.
DURA8-2-T	Globe valve connection gasket. Teflon. Cold water side.
DURA8-2-C	Globe valve connection gasket. Copper. Steam side.
DURA8-3	Check valve connection gasket. Teflon coated copper.
DURA8-4	Temperature control stem guide Teflon filling.
DURA8-6	Globe valve stem guide nut gasket. Teflon.
DURA8-7	Globe valve stem guide Teflon filling.
DURA8-10B	Globe valve poppet. Brass.
DURA8-10S	Globe valve poppet. Stainless steel.
DURA8-12B	Steam chamber cover plate assembly. Bronze.
DURA8-12S	Steam chamber cover plate assembly. Stainless steel.
DURA8-13	Steam poppet. Stainless steel.
DURA8-14S	Steam poppet seat. Stainless steel. (Must be purchased with DURA8-13)
DURA8-15	Steam poppet seat copper gasket.
DURA8-18	Temperature control chamber plate gasket. Teflon.

SuperKlean Washdown Products

Frequently asked questions:

Question:	Answer:
Depending on the facility, is a strainer required at the inlets on the mixing unit to prevent debris from entering the unit?	SuperKlean does not recommend the use of strainers at the inlets simply because they reduce the flow into the unit and thus affects the operation of the unit. It is recommended that all inlet supply lines are thoroughly flushed prior to installation to rid them of debris.
Do you need to install a steam trap?	SuperKlean highly recommend the use of a steam trap to rid unit of condensation build up which causes steam poppet lock-up if unit sits at idle for a long period of time. Steam poppet lock up will make unit inoperable.
Can you use both outlets at the same time?	Because of the variety of scenarios, SuperKlean recommends that the customer try both outlets at the same time to see if they are satisfied with the output flow rates. Please note that higher inlet pressures are preferred for the use of both outlets. If insufficient flow rates are noticed, one outlet at a time will have to be used.
What is the output pressure of the mixing unit?	Output pressure is very similar to input water pressure.
What can I do if my inlet water pressure is below 30 PSI?	SuperKlean highly recommends the use of an inline pressure pump in order to boost incoming water pressure. We do not recommend and will not warranty the mixing station if parts are removed and/or modified to allow the unit to operate under our specific inlet pressure requirements.

SuperKlean Washdown Products

Troubleshooting:

Symptom:	Corrective Action:
Nozzle delivers cold water only or temperature output is not high enough after regulating unit	<p>Make sure that you have a minimum water pressure of 30 PSI. Gradually open steam supply globe valve until completely open or desired temperature is achieved. If this does not correct problem, check for steady steam pressure. If steam pressure is steady and steam globe valve is fully opened, try adjusting temperature output by closing temperature control hand wheel on the side of the unit. If temperature control hand wheel is completely closed, gradually begin to close cold water supply globe valve until desired temperature is achieved. If there is still no hot water exiting nozzle, contact us.</p> <p>Note: Steam pressure should normally be higher than water pressure to achieve reasonable water temperature output. The use of pressure gauges at inlets is highly recommended.</p>
Steam escapes from hose nozzle sporadically	Immediately shut down and decommission washdown station and contact us.
Hot water outlet temperature is too high	<p>Gradually adjust temperature control hand wheel on the side of the unit by opening it. If completely opened, gradually close steam supply globe valve until completely closed or desired temperature is achieved while pulling nozzle trigger. If this does not correct problem, check to make sure water supply is fully open and steady water pressure is available. Check for steady steam supply pressure. If water temperature is still too high, decommission the unit and contact us.</p> <p>Note: Steam pressure should normally be higher than water pressure to achieve reasonable water temperature output. If steam to water pressure is more than 2:1 ratio, higher temperature output is expected. The use of pressure gauges at inlets is highly recommended.</p>
Outlet pressure is too low or non-existent	Ensure all steam and water valves leading to and including the washdown unit are fully opened and that a minimum pressure of 30 PSI on both inlets is available. Re-adjust globe valves to desired temperature and check pressure again.
Leaking pipe threads	Ensure that pipe thread sealant was used when mating threads. Standard pipe threads require pipe thread sealant to make a proper seal (e.g. ANSI/ASME B1.20.1 Pipe Thread Standard)
Water pressure/temperature is sporadic at outlet	Verify you meet and can maintain the required water and steam pressures. The use of pressure gauges at inlets is highly recommended. If pressures on both inlets are not constant, the use of a pressure regulator is recommended.