

Series 40276

Globe Valve

Features

- 200 WOG @ 350 °F
- 316 stainless steel
- Screwed bonnet
- Non-rising stem
- Hydrostatic shell test at 300 psi
- Hydrostatic seat test at 220 psi



Valves, Automation & Controls



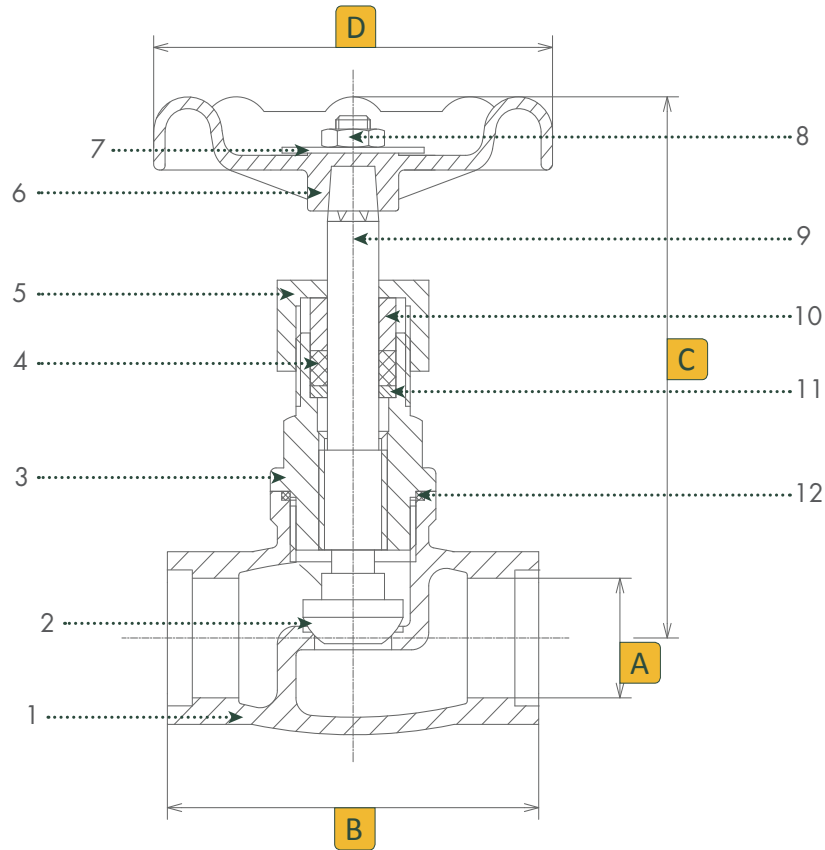

Dimensions (Inches)

Size	A	B	C	D
1/4	0.40	2.01	4.41	2.76
3/8	0.49	2.01	4.41	2.76
1/2	0.59	2.56	4.21	2.76
3/4	0.79	2.95	4.59	2.76
1	0.98	3.54	5.16	3.15
1-1/4	1.26	4.13	5.67	3.15
1-1/2	1.57	4.65	6.46	3.94
2	1.97	5.43	6.93	3.94

No.	Part Name	Qty	Material
1	Body	1	316 Stainless Steel
2	Core	1	316 Stainless Steel
3	Bonnet	1	316 Stainless Steel
4	Packing	1	PTFE
5	Gland Nut	1	304 Stainless Steel
6	Hand Wheel	1	Aluminum
7	Name Plate	1	Aluminum
8	Nut	1	304 Stainless Steel
9	Stem	1	316 Stainless Steel
10	Metal Padding	1	304 Stainless Steel
11	Washer	1	316 Stainless Steel
12	Seal	1	PTFE

Ordering

Fig: 1 - 40276 - SW
Description: 1" - Series 40276 - Socket Weld

Size	Series	Ends
1/4	40276	TE Threaded
3/8		SW Socket Weld
1/2		
3/4		
1		
1-1/4		
1-1/2		
2		

Due to continuous development of our product range, we reserve the right to change the dimensions and information for this product as required.