

REOTEMP INSTRUMENTS Product drawing

THERMOWELL WITH:

- Threaded Process Connection
- Stepped Shank

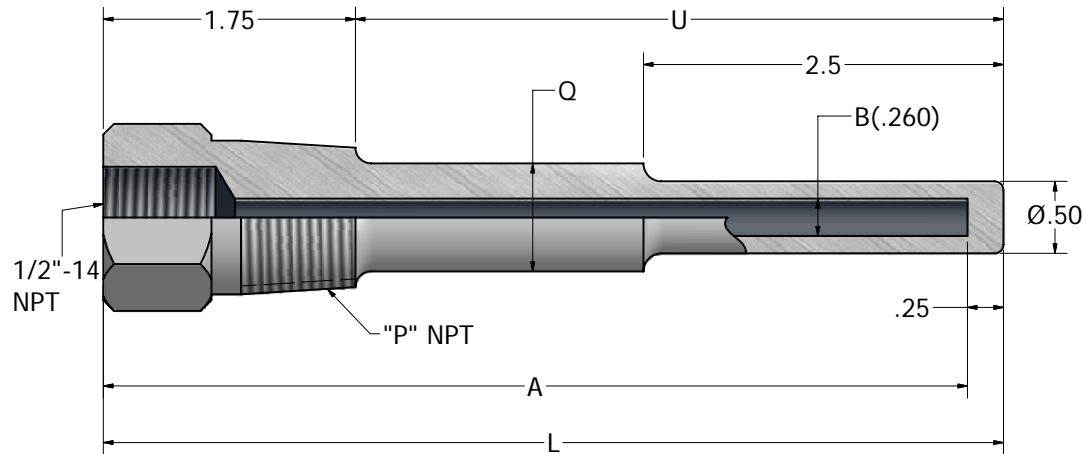

Reotemp Part#: **ST6316-H**

Material: **316 Stainless (std)**

Dimensions (inches):

Bore Dia. B:	.260" bore, for 1/4" dia. Element"
Element Length A:	6"
Overall Length L:	6.25"
Insertion Length U:	4.5"
Process P:	1/2" NPT
Shank dia. Q:	.625"

Options included (not depicted in Dwg.)

Option 1:	
Option 2:	
Option 3:	
Option 4:	
Option 5:	
Option 6:	
Option 7:	
Option 8:	

Drawing No.: **TWC-TP-ST6316-H**

Data production date: 01/24/2010

THIS DRAWING AND SPECIFICATIONS ARE THE PROPERTY OF REOTEMP INSTRUMENT CORP., AND ARE ISSUED IN STRICT CONFIDENCE AND SHALL NOT BE REPRODUCED, COPIED OR USED AS THE BASIS FOR MANUFACTURE OR SALE OF ITEMS DEPICTED HEREIN WITHOUT WRITTEN PERMISSION FROM REOTEMP INSTRUMENT CORP.

NOTES (UNLESS OTHERWISE SPECIFIED)

- 1) DIMENSIONS ARE IN INCHES
- 2) DIMENSIONS ARE SUBJECT TO CHANGE. FINAL DIMENSIONAL VERIFICATION CAN BE REQUESTED AT TIME OF ORDER.

REVISIONS			
REV	DESCRIPTION	DATE	APPROVED
X1	INITIAL RELEASE	5/14/10	MO

PART NAME THERMOWELL, THREADED, STEPPED SHANK		REOTEMP Instrument Corporation		DATE 5/14/10
UNLESS OTHERWISE SPECIFIED DIMENSIONS ARE IN INCHES TOLERANCES ARE:		10656 Roselle Street San Diego, CA 92121 USA Phone: (858) 784-0710 Fax: (858) 784-07-20		DRAWN BY JHRichter
FRACTIONS DECIMALS ANGLES ±1/32 .X ±.03 ±5° .XX ±.01 .XXX ±.005		REOTEMP		APPROVED MO
PART NO SEE CHART	SIZE C	CAGE CODE 24793	BASE DWG NO TWC-TP	REV X1
FIRST USED ON	SCALE: NTS	FILE NAME: CF	SHEET 1 OF 1	