

Operating Instructions

Series LC Spring Driven Hose Reels

Stainless Steel Model Numbers:

[LC607 OLS](#)

[LC800 OLS](#)



Dimensions

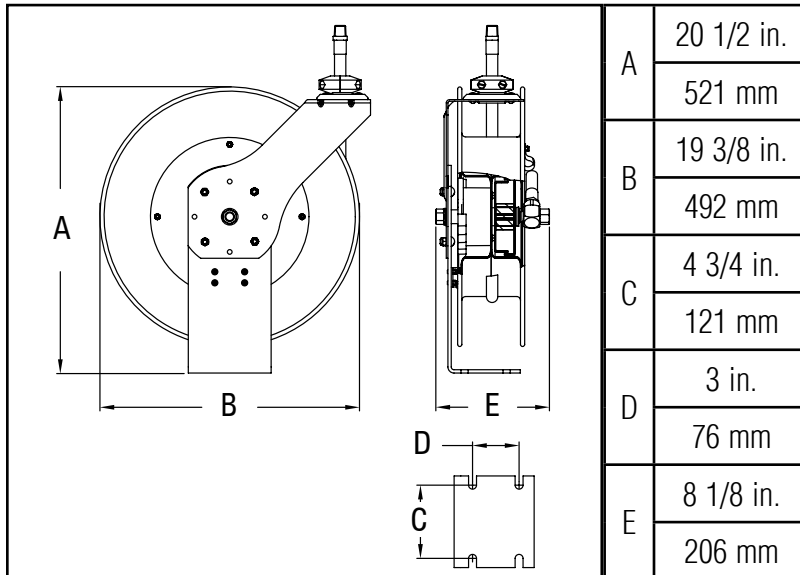

IMPORTANT

Read this manual carefully before installing, operating or servicing this equipment.

SAFETY

Personal injury and/or equipment damage may result if proper safety precautions are not observed.

- Ensure that reel is properly installed before connecting input and output hoses.
- Bleed air/water pressure from system before servicing reel.
- Before connecting reel to supply line, ensure that pressure does not exceed maximum working pressure rating of reel.
- Remember, even low pressure is very dangerous and can cause personal injury or death.
- Be aware of machinery and personnel in work area.
- If a leak occurs in the hose or reel, remove system pressure immediately.
- A high tension spring assembly is contained within the reel. Exercise extreme caution.
- Pull hose from reel by grasping the hose itself, not the control valve.
- Ensure that reel, hose, and equipment being serviced are properly grounded. Use an ohmmeter to check ground continuity.
- If reel ceases to unwind or rewind, remove system pressure immediately. Do not pull or jerk on hose!
- Treat and respect the hose reel as any other piece of machinery, observing all common safety practices.



John M. Ellsworth Co., Inc.

P.O. Box 240072
8700 West Bradley Road
Milwaukee, WI 53224

800-333-3331 **PHONE**

info@jmesales.com **E-MAIL**
www.JMEsales.com **WEB**

MOUNTING

Caution: Unless reel was specified differently when ordering, maximum installation height is 16 ft. (4.8 m). Do not exceed this distance.

1. Unpack and inspect reel for damage. Turn by hand to check for smooth operation. Check for completeness.
2. Position reel on floor, wall, or ceiling (not recommended for mobile applications).
3. Secure into place using four (not included) bolts (fig. 1). Depending on where the reel is placed, it may be necessary to adjust the hose bumper and guide arm to use the hose properly.

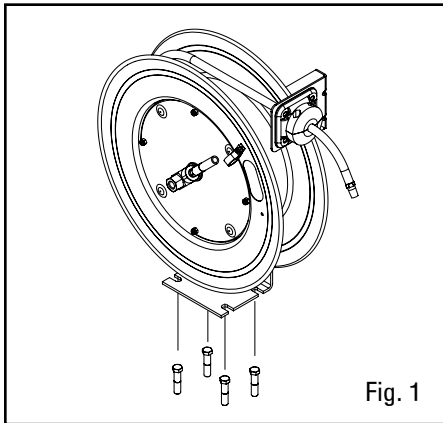

Fig. 1

INSTALLING THE INPUT HOSE

Caution: Use flexible hose connection at input. Do not use rigid plumbing.

1. Apply pipe thread sealant to threads on reels.
2. Connect supply line hose to main shaft input (fig. 2).

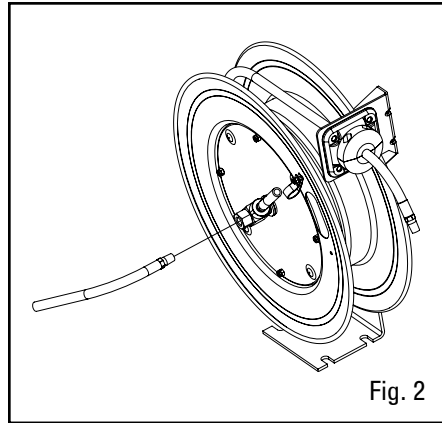

Fig. 2

REMOVE GUIDE ARM

1. Pull out hose until latch pawl is engaged.
2. Remove slotted screws holding bumper place.
3. Remove bumper.
4. Allow hose to retract into reel.
5. Remove 4 nuts holding guide arm on base (fig. 3).
6. Pull guide arm off of base.

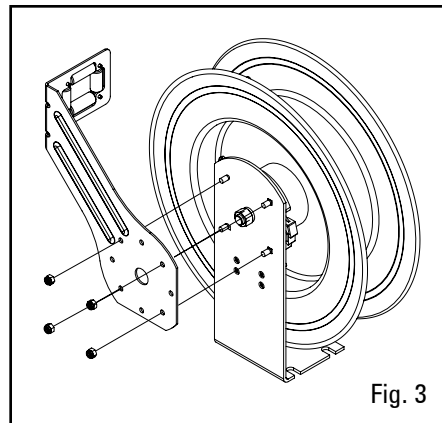

Fig. 3

POSITION GUIDE ARM

1. Remove guide arm.
2. Position the guide arm in one of five positions (fig. 4).
3. Install and tighten four nuts on guide arm.
4. Tighten drive spring by turning spool two or three revolutions to engage latch pawl.

5. Pull hose through roller opening in guide arm.
6. Position bumper on hose.
7. Install and tighten screws in bumper.

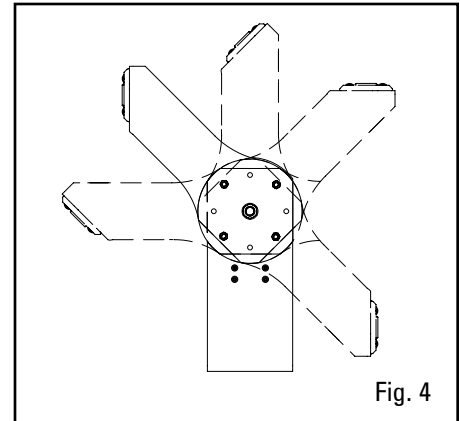

Fig. 4

REPLACE LATCH PAWL

1. Retract hose onto reel until bumper is against guide rollers and latch pawl is not engaged.
2. Remove nuts that fasten latch pawl assembly with socket-head cap screws (fig. 5).
3. Replace latch pawl assembly and tighten nuts.

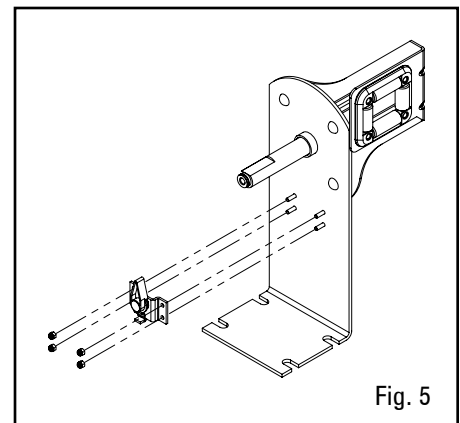

Fig. 5

REPLACE HOSE

Install hose

1. Route the hose through the guide arm rollers and opening of the spool.
2. Apply thread tape or sealant to hose threads.
3. Screw hose fitting into threaded fitting on swivel.
4. Tighten connection with a wrench on both fittings.
5. Install the hose clamp (fig. 6).
6. Install hose bumper on working end of hose.
7. Disengage latch pawl and allow hose to retract.

Remove the hose

1. Pull out the hose leaving 2 to 3 ft. (0.6 to 0.9 m) on the spool.
2. Engage the latch pawl.
3. Remove the screw nuts on the inside of the spool (fig. 6).
4. Remove the hose clamp.
5. Unthread the hose at the connection to the swivel.
6. Use a wrench on both fittings or the swivel may be damaged.
7. Remove the hose.

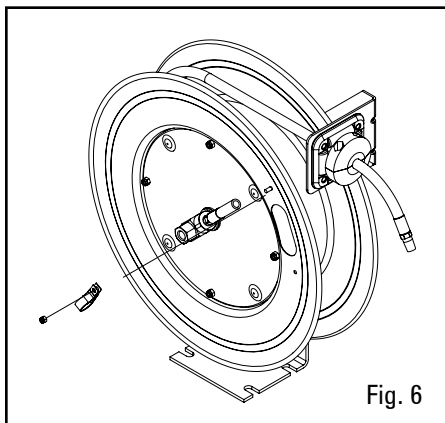

REPLACE SWIVEL

Caution: Use flexible hose connection at input. Do not use rigid plumbing.

1. Remove the hose (see Replace Hose).
2. Remove swivel by unscrewing the threaded stem from the main shaft (fig. 7).
3. Replace swivel by screwing threaded stem of swivel into main shaft of reel.
4. Replace the hose.

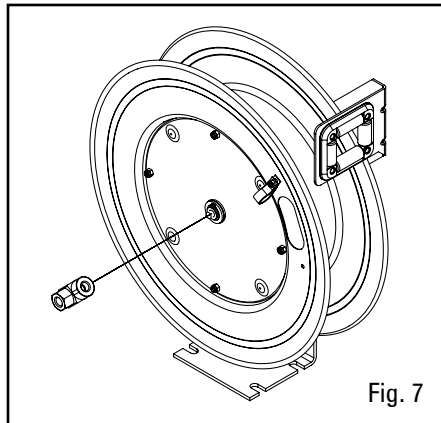

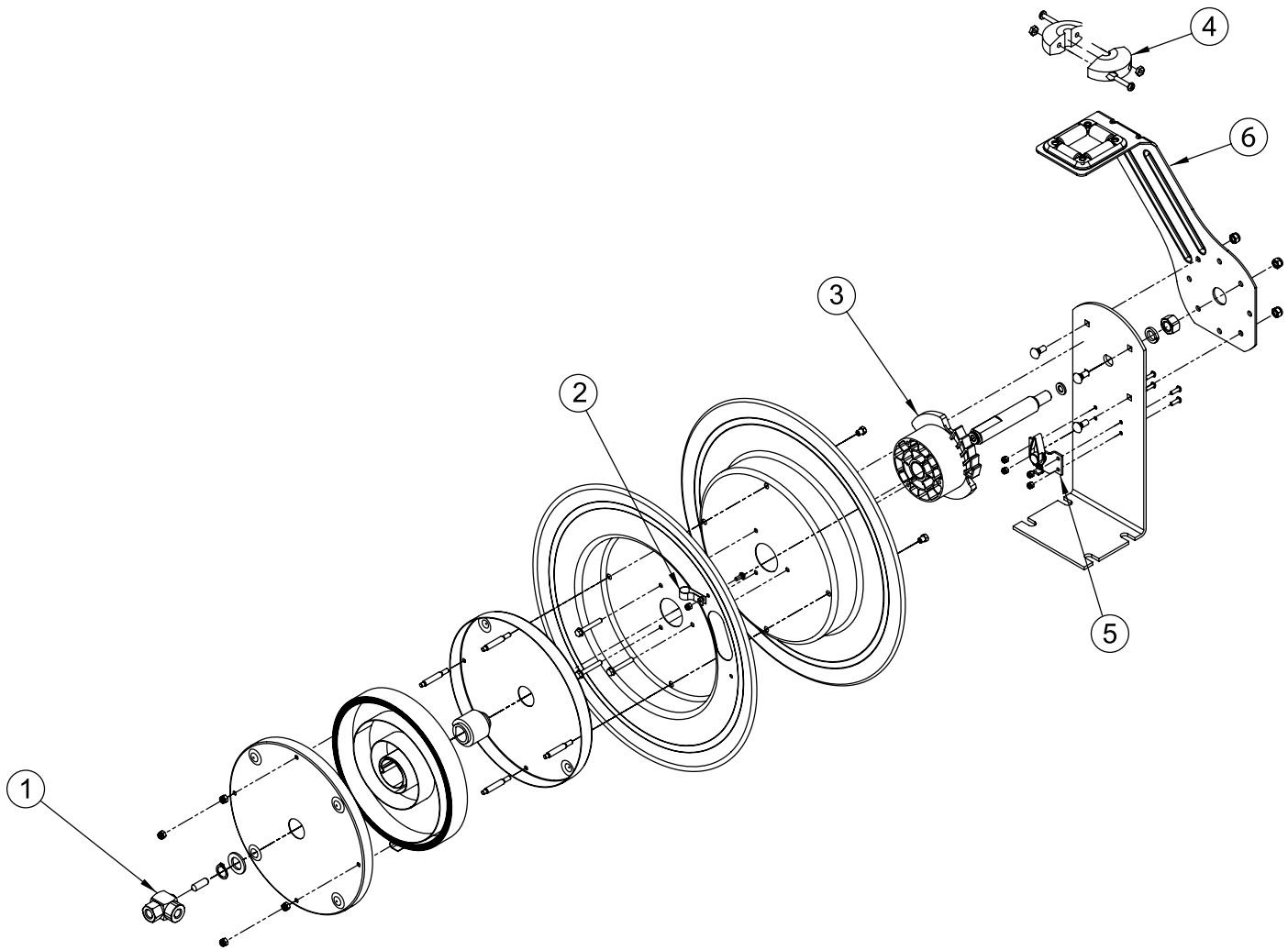

Item #	Description	# Req.	LC607 OLS	LC800 OLS
1	Brass Swivel Assembly	1	S602657	S602658
2	Stainless Hose Clamp	1	S262887	S262888
3	Ratchet and Bushing Assembly	1	S602659	S602659
4	Bumper Stop Assembly	1	1-HS1004-3	2-HS1004-3
5	Stainless Latch Pawl Assembly	1	S602660	S602660
6	Guide Arm Assembly	1	S262964	S262964
Hose I.D. x Capacity			3/8" x 70'	1/2" x 50'
Reel Inlet Connection			1/4" (F)NPTF	1/2" (F)NPTF
Max. Operating Pressure			300 psi	300 psi
Max. Operating Temperature			150 °F	150 °F