

PART #	# PORTS	INLET	OUTLET	A
H-75-75-3	3	3/4 NPT	3/4 NPT	8.00
H-75-75-4	4	3/4 NPT	3/4 NPT	10.75
H-75-75-5	5	3/4 NPT	3/4 NPT	13.50

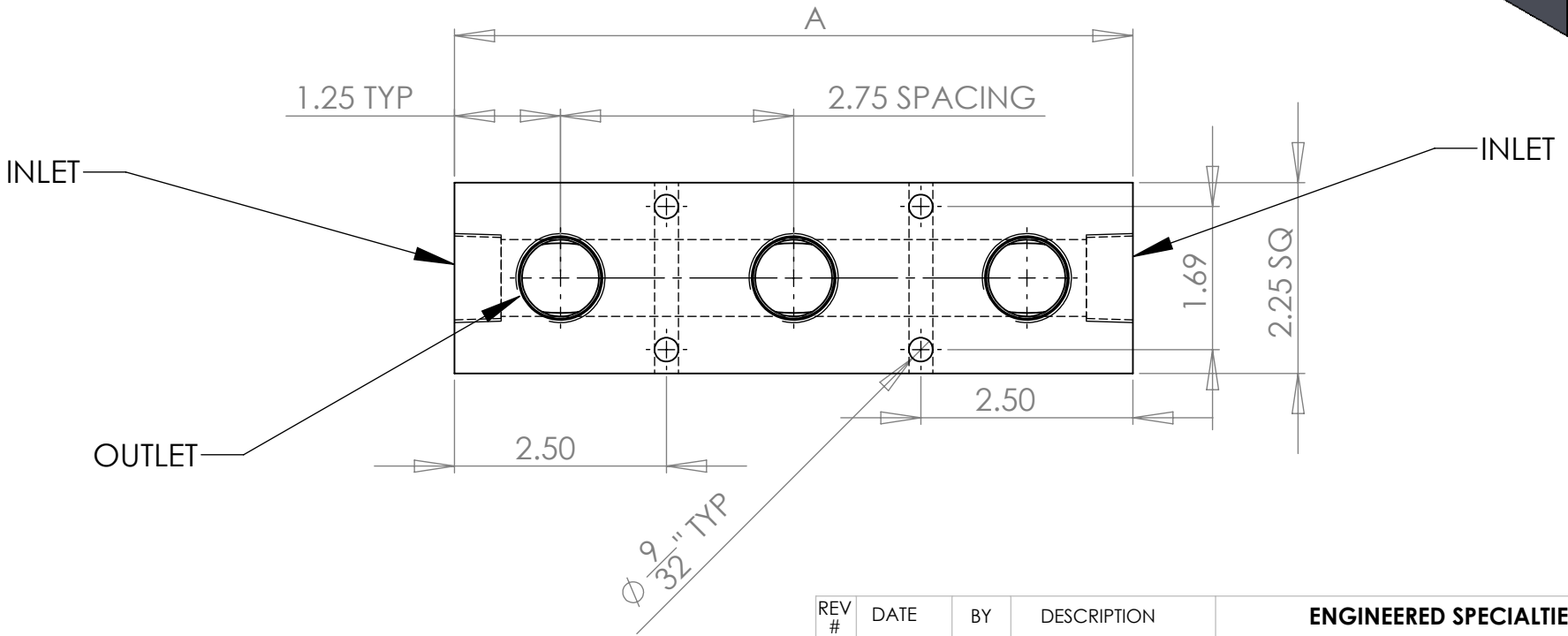
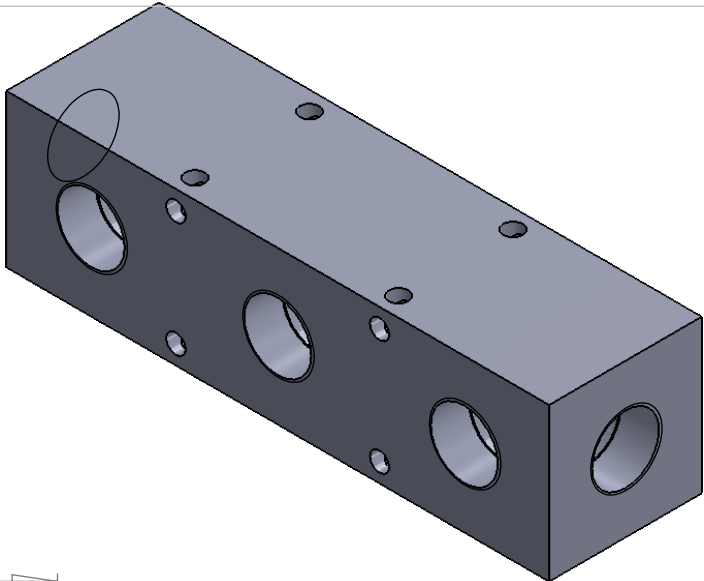

REV #	DATE	BY	DESCRIPTION	ENGINEERED SPECIALTIES, LLC	
				<b>TOLERANCES UNLESS OTHERWISE SPECIFIED</b> FRACTION OF WHOLE ±.030 TWO DIGIT DECIMAL ±.010 THREE DIGIT DECIMAL ±.003 FOUR DIGIT DECIMAL ±.0005 ANGLE ±1°	DWG. NAME 3/4" MANIFOLD
					DWG. NO. H-75-75
					MATERIAL 6061 ALUM
					FINAL FINISH STRAIGHT SAND
1	1-2018	acr	increased spacing to 2.75		DRAWN BY CAR
					DATE 7-15-2014