



FUEL MANAGEMENT SYSTEMS



DISPENSERS



KITS



PUMPS



METERS



NOZZLES

# CUBE 70 B.SMART

## FEATURES

- STURDY STRUCTURE
- COMPACT DESIGN
- NATIVE WITH B.SMART CLOUD SOFTWARE
- IP55

The CUBE 70 B.SMART fuel dispenser, available in the 15GPM version with AC supply, is equipped with a self-priming vane pump with a built-in bypass that ensures high performance. The anti-vibration support of the diesel dispenser guarantees silent operation and practicality, while the mechanical seal and the thermal protection of the induction motor against overheating makes the product reliable and safe. CUBE 70 B.SMART is equipped with an automatic nozzle with swivel connection. The installation of the mesh filter on the suction side ensures the pump longevity, as it prevents foreign bodies from ending up in the rotor and causing a blockage and consequent damage.

### PERFORMANCE

<b>UP TO 15 GPM</b>	<b>AC VOLTAGE</b>
FLOW RATE	POWER
<b>± 0.5%</b>	<b>BLUETOOTH</b>
ACCURACY	CONNECTION



CUBE B.SMART



### PACKAGING

CODE	WEIGHT		PACKAGING			N. BOXES / EUROPALLET	
	KG	LBS	MM	INCH	PCS/BOX	✈	🚚

#### AC VERSION

FO0598500	24	53	380 X 380 X 4	15 X 15 X 18.9	1	-	-
-----------	----	----	---------------	----------------	---	---	---



FILTRATION



TANK MONITORING



HOSE REEL



ACCESSORIES



MERCHANDISE



AIR



ANTIFREEZE



BIODIESEL



DIESEL



FOOD



GASOLINE



GREASE



KEROSENE



OIL



WATER



WINDSCREEN

## CHART

### PANTHER PUMP

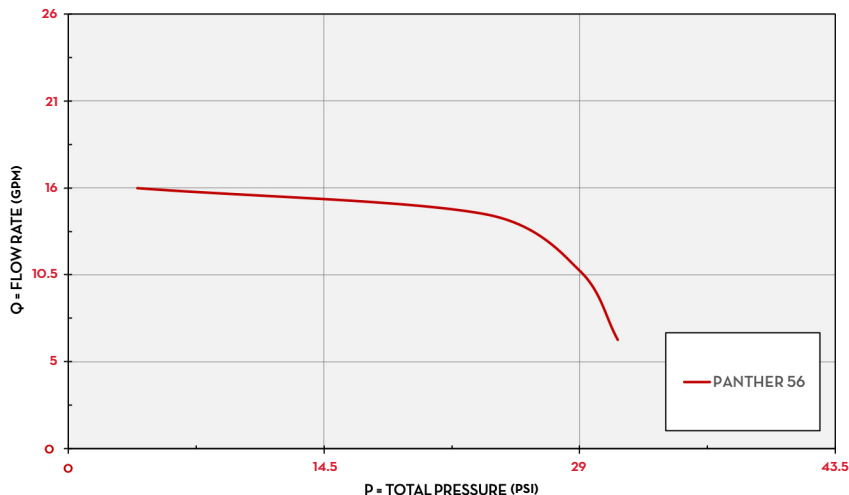

**TYPE OF FLUID** DIESEL  
**TEMPERATURE** 48-68-42 °F

## IN THE BOX

- CUBE B.SMART DISPENSER
- AUTOMATIC NOZZLE
- DELIVERY HOSE
- DRIVER ACCESS ADD-ON
- INSTRUCTION MANUAL

## DETAILS



## DIMENSIONS (inches)

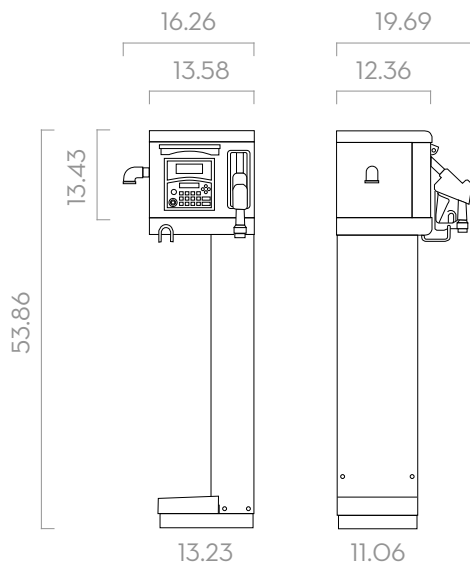

## INCLUDES

- PANTHER AC PUMP
- K600/3 METER
- AUTOMATIC NOZZLE

## TECHNICAL DATA

CODE	DESCRIPTION	FLUIDS TYPE	FLOW RATE		VOLTAGE		PUMP TYPE	METER TYPE	NOZZLE TYPE	FILTER H2O FILTER	INLET NPT	HOSE	
			L/MIN	GPM	AC V/HZ	VOLT						LENGTH	Ø

### AC VERSION

FO0598500	CUBE 70 B.SMART 120V - 50 DRIVERS	D	56	15	120V	60 HZ	PANTHER 56	K600/3	A60	NO	1"	13FT	1"
-----------	-----------------------------------	---	----	----	------	-------	------------	--------	-----	----	----	------	----