

JME

THIS EQUIPMENT HAS A ONE YEAR LIMITED WARRANTY WHICH COVERS DEFECTIVE MATERIAL AND WORKMANSHIP. IT IS THE USER'S RESPONSIBILITY TO TRAIN THEIR EMPLOYEES IN THE PROPER HANDLING AND LOADING OF THIS PRESSURE TANK AND ITS CONTENTS AND TO INSURE PRODUCT COMPATIBILITY WITH THE MATERIALS OF CONSTRUCTION.

ALL OF THESE PROCEDURES ARE TO BE IN ACCORDANCE WITH TITLE 49 OF THE CODE OF FEDERAL REGULATIONS.

REMOVE PRESSURE FROM CONTAINER BEFORE LOOSENING CLAMP RING OR DRUM COVER.

PLEASE CHECK FOR DAMAGE TO THIS EQUIPMENT - DAMAGE MUST BE NOTED ON THE PRESENT BILL AT THE TIME THE EQUIPMENT IS RECEIVED FROM THE CARRIER.

THIS EQUIPMENT HAS BEEN CLEANED WITH CLEANING AGENTS AND MAY HAVE RESIDUE LEFT IN THE UNIT. PLEASE CHECK THE UNIT CAREFULLY BEFORE FILLING. FINAL CLEANING MAY BE REQUIRED.

THE DRUM COVER AND GASKET SHOULD BE CHECKED FOR PROPER ASSEMBLY AND THE CLAMP RING SECURELY TIGHTENED PRIOR TO EACH SHIPMENT. IF THE DRUM COVER INCLUDES A FIBERGLASS VENT, IT SHOULD BE INSPECTED AND REGRINDED OR REPLACED IF NECESSARY PRIOR TO EACH SHIPMENT.

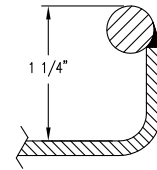

DETAIL ITEM #7
SCALE: NONE

DRUM NECK SECTION
SCALE: NONE

NOTE: IF APPLICABLE, PER TITLE 49CFR, BOTH THE 22 1/2" CLOSURE CLAMP RING, BOLT, NUT AND THE 2" BUNG PLUG MUST BE TIGHTENED TO A TORQUE OF 30 Ft.-lbs. TO SATISFY THE PERFORMANCE REQUIREMENTS.

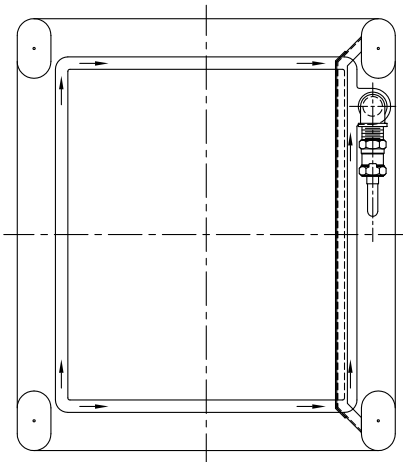
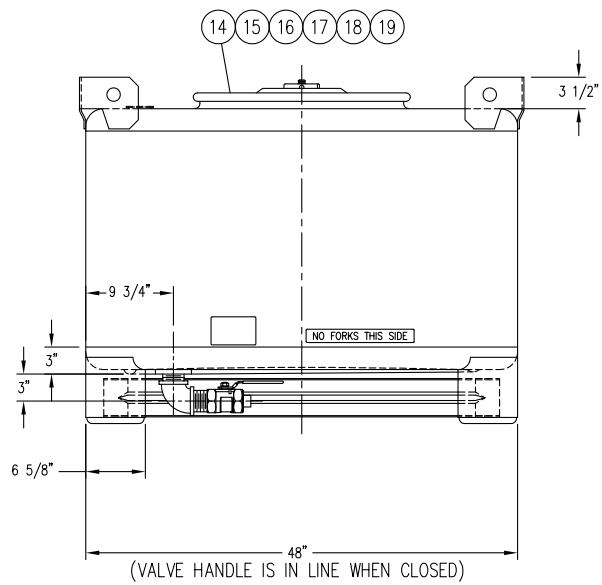
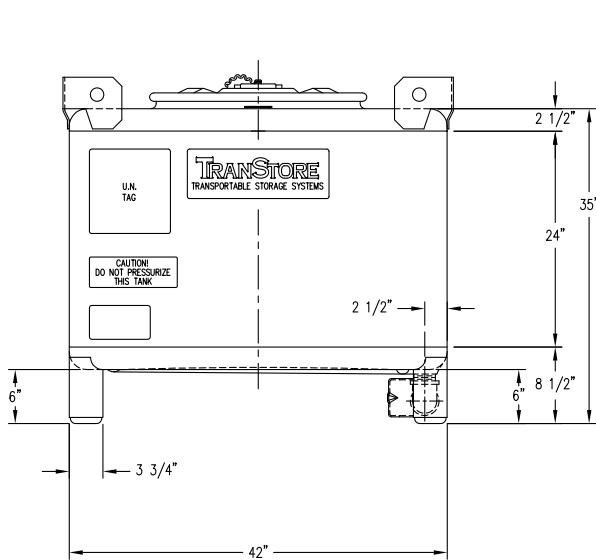

NOTE: BOTTOM SUMP SLOPES 1/2" TOWARDS OPENING

NOTES:

1. REMOVE ALL BURRS AND SHARP EDGES.
2. TANK FABRICATED W/2" RADIUS CORNERS AND HIGH CONTOUR LEGS.
3. MATERIAL OF CONSTRUCTION IS 304 S.S. AND NOTED.
4. INSIDE OF TANK TO BE WIPED CLEAN AT FINAL ASS'Y.
5. WARRANTY TAG TO BE WIRED TO CLAMP RING AT FINAL ASS'Y.



John M. Ellsworth Co., Inc.

P.O. Box 240072
8700 West Bradley Road
Milwaukee, WI 53224

800-333-3331 **PHONE**
800-563-8848 **FAX**

info@jmesales.com **E-MAIL**
www.JMEsales.com **WEB**