

MAXIMATOR®
Typ / type: DLE 15-2-NN-M
 Art.-Nr. / Item No.: 3250.0332

pL max.: 10bar / 145psi
 i: 1:30
 pA min.: 7bar / 102psi
 pB max.: 300bar / 4350psi
 T: -20°C ... +100°C

Anschluss / Connection	Größe	Size
PL	1/2 NPT	1/2 NPT
A	1/4 NPT	1/4 NPT
B	1/4 NPT	1/4 NPT
E	G 1/2	1/2 BSP
X	1/8 NPT	1/8 NPT
V	∅3	∅3
Y	1/8 NPT	1/8 NPT
Z1	G 1/8	1/8 BSP
Z2	G 1/8	1/8 BSP
Z3	G 1/8	1/8 BSP
Z4	G 1/8	1/8 BSP
Z6	G 1/8	1/8 BSP
SFP	G 1/8	1/8 BSP



John M. Ellsworth Co., Inc.

P.O. Box 240072
 8700 West Bradley Road
 Milwaukee, WI 53224

800-333-3331 PHONE
 info@jmesales.com E-MAIL
 www.JMESales.com WEB

This document is copyright protected. Copying or editing this document is only allowed upon Maximator GmbH's written approval.		Dieses Dokument ist urheberrechtlich geschützt. Eine Vervielfältigung oder Bearbeitung des Dokuments ist nur mit schriftlicher Genehmigung der Maximator GmbH erlaubt.		MAXIMATOR®	
Scale	1 : 2	Weight	25,33 kg	Format	A1
Sheet	1 / 3				
gty/ty	Datum/Date	Name	(Benennung/Title)		
Erste	25.07.2016	Stuhmann	DLE 15-2-NN-M		
Bearb.	27.09.2022	TKunze			
Gepr.	27.09.2022	SuSchiele	DLE 15-2-NN-M		
Freigegeben					
Halbzeug	raw material:	(Zeichnungsnummer/drawing number)		Rev.	(Artikel-Nr./order number)
Werkstoff	basic material:	VP16.00.1105		C	B250.0332
Urspr.	VP16.00.0914	Ers.f./replaces:	25.05/26.05	Ers.d./replaces by:	

US - representative:
 MAXPRO TECHNOLOGIES, INC.
 7728 Klier Drive
 FAIRVIEW, PA 16415
 PHONE: (814) 474 - 9191
 FAX: (814) 474 - 9391

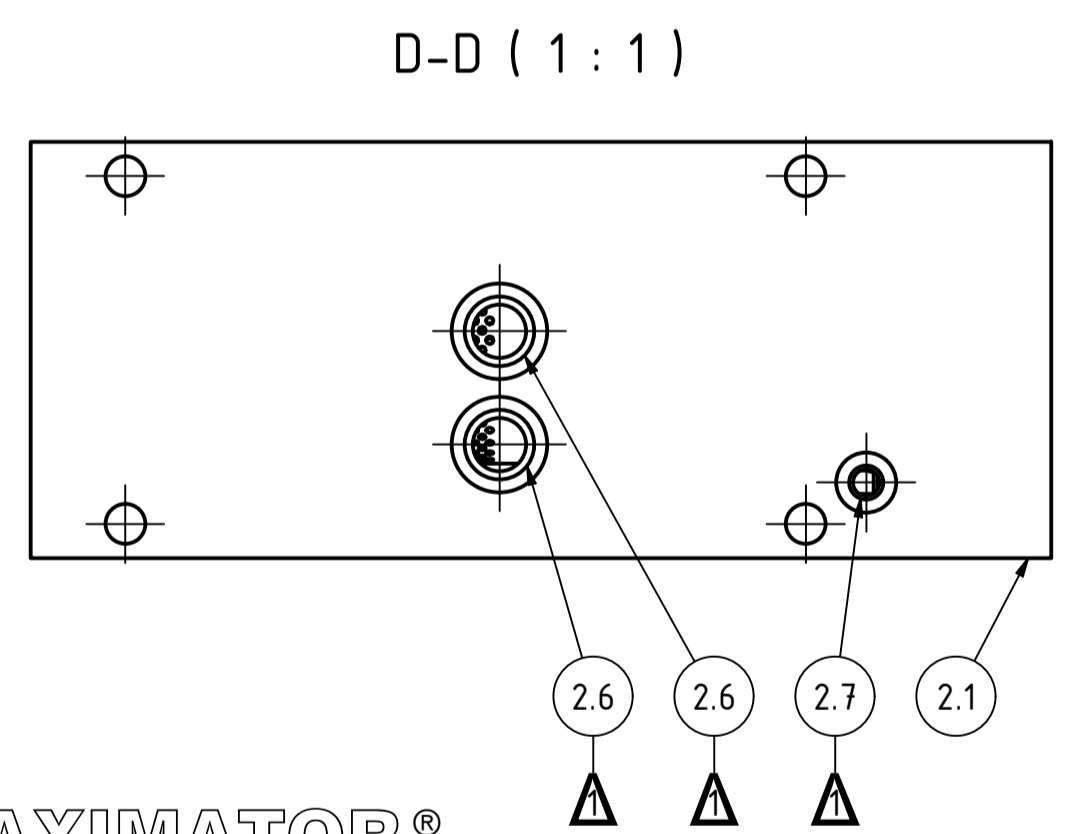
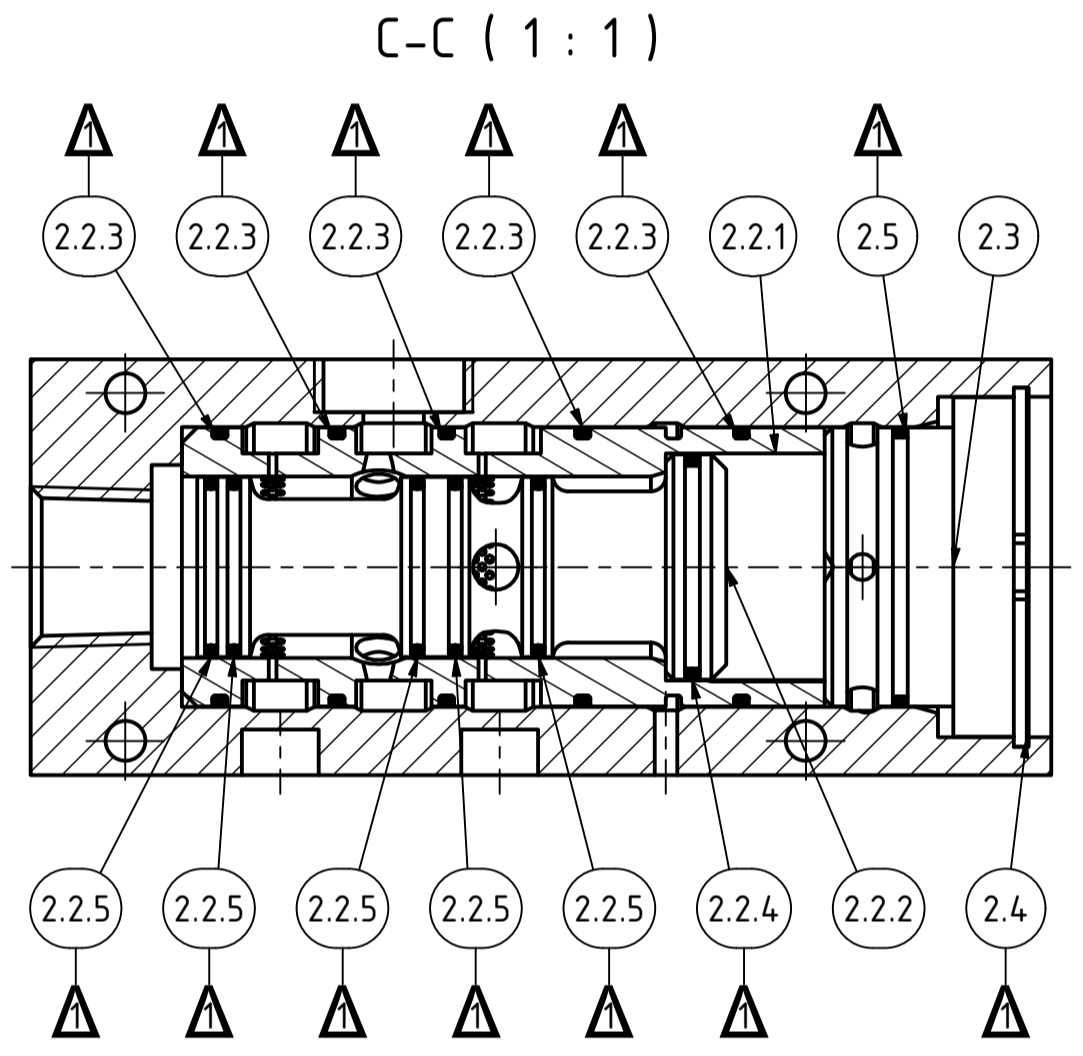
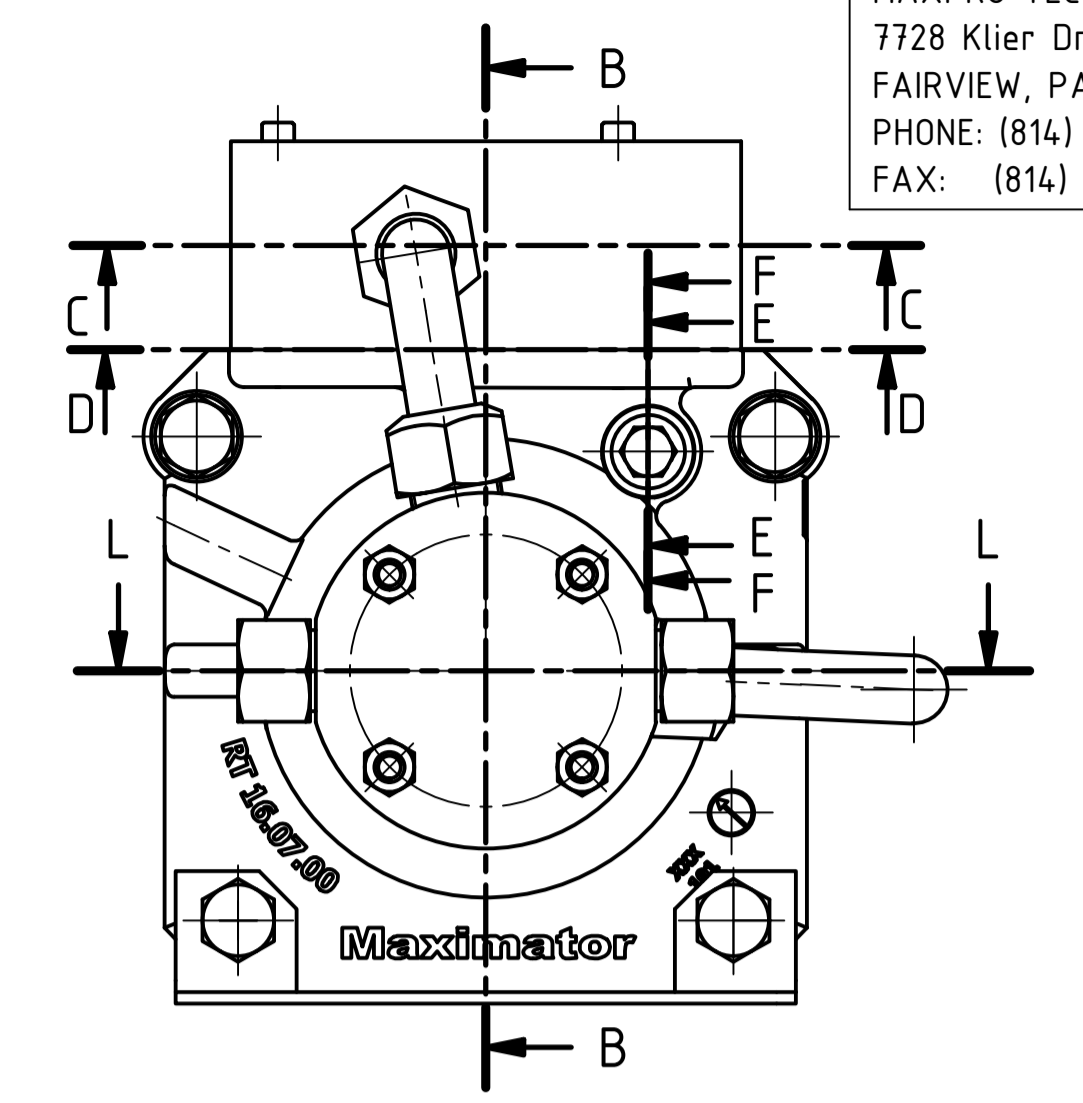
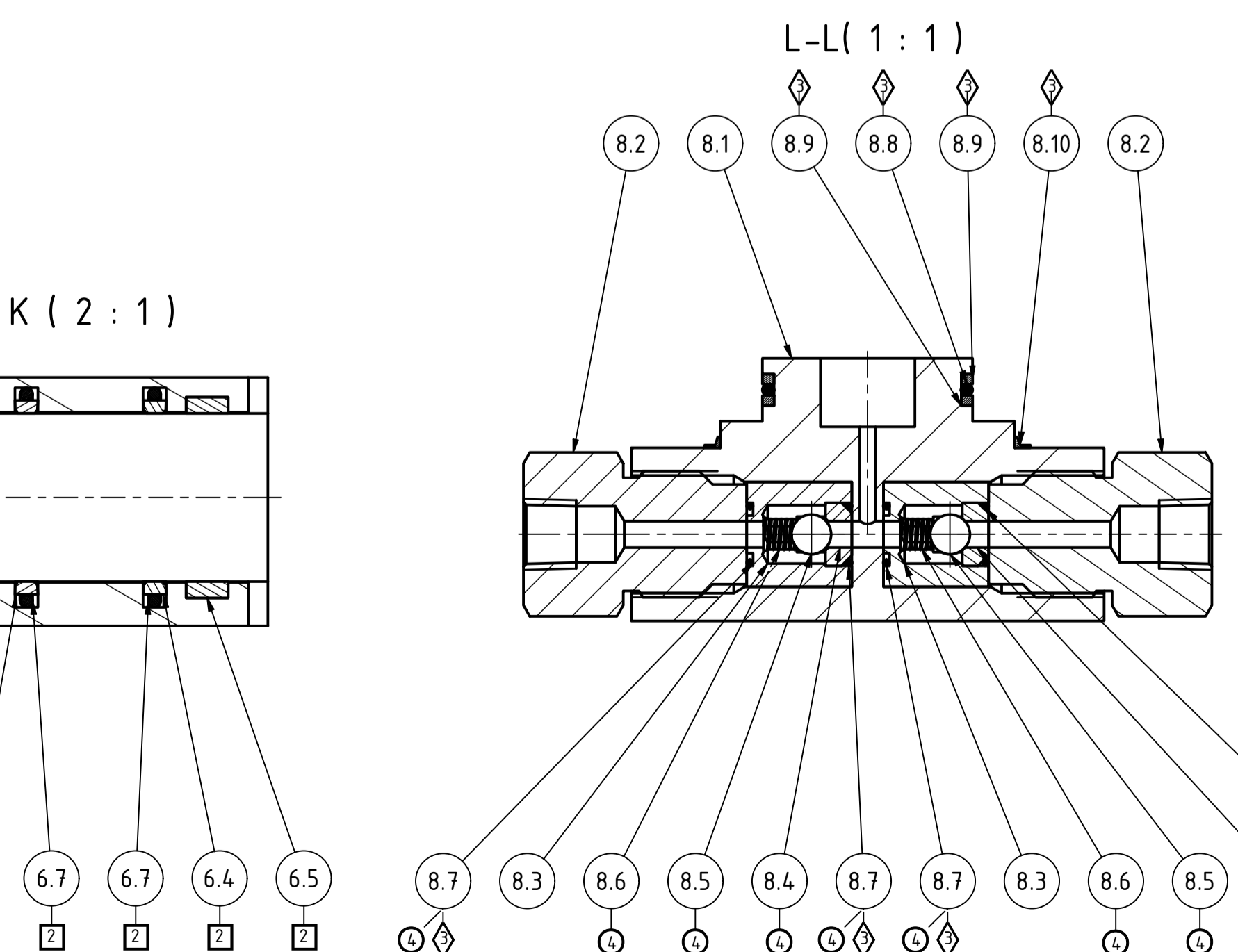
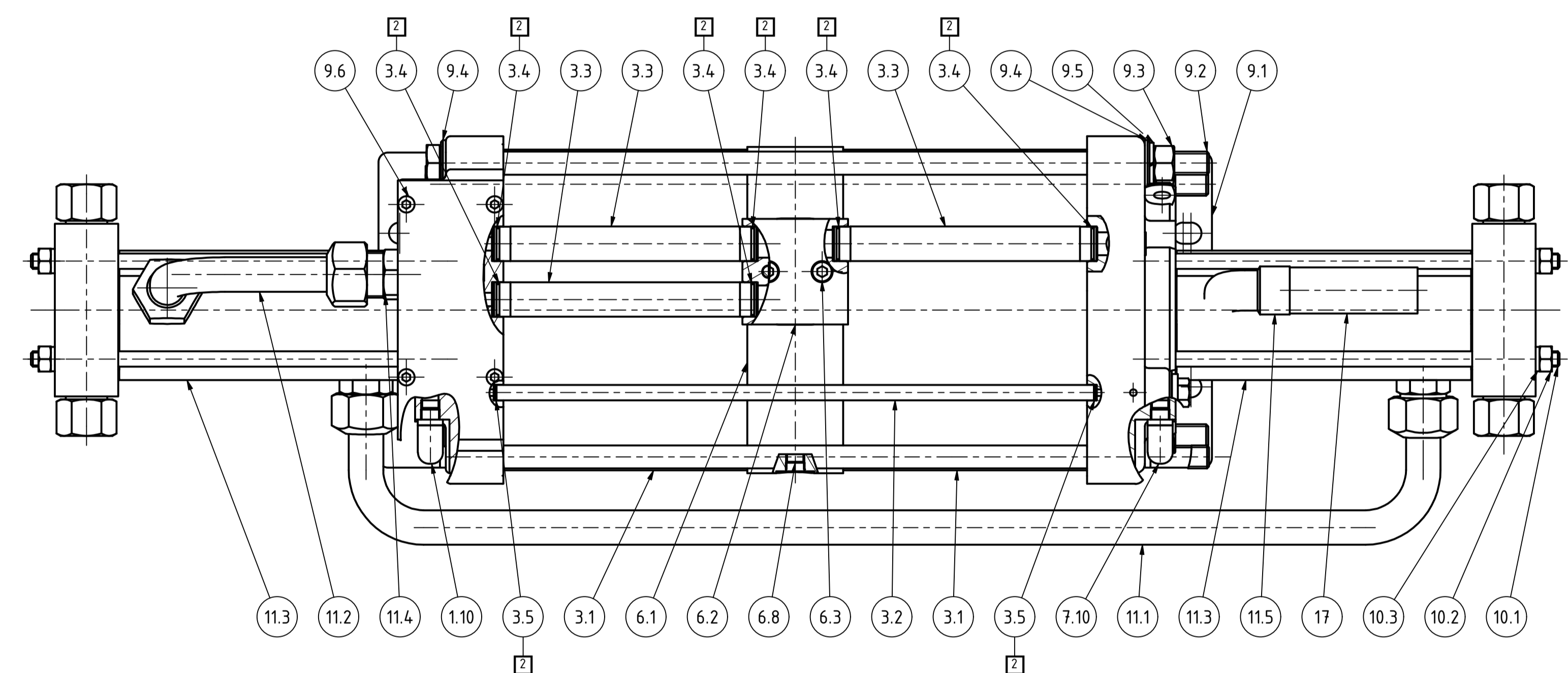
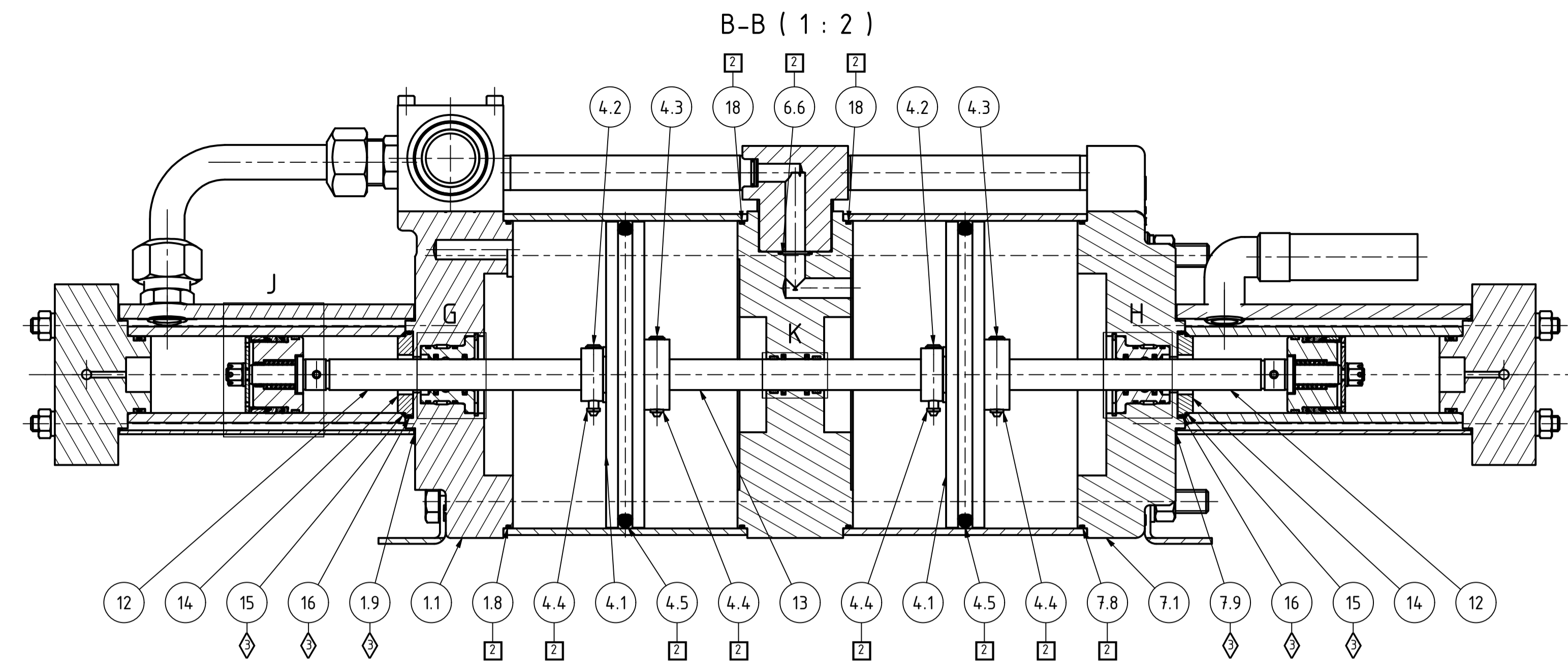
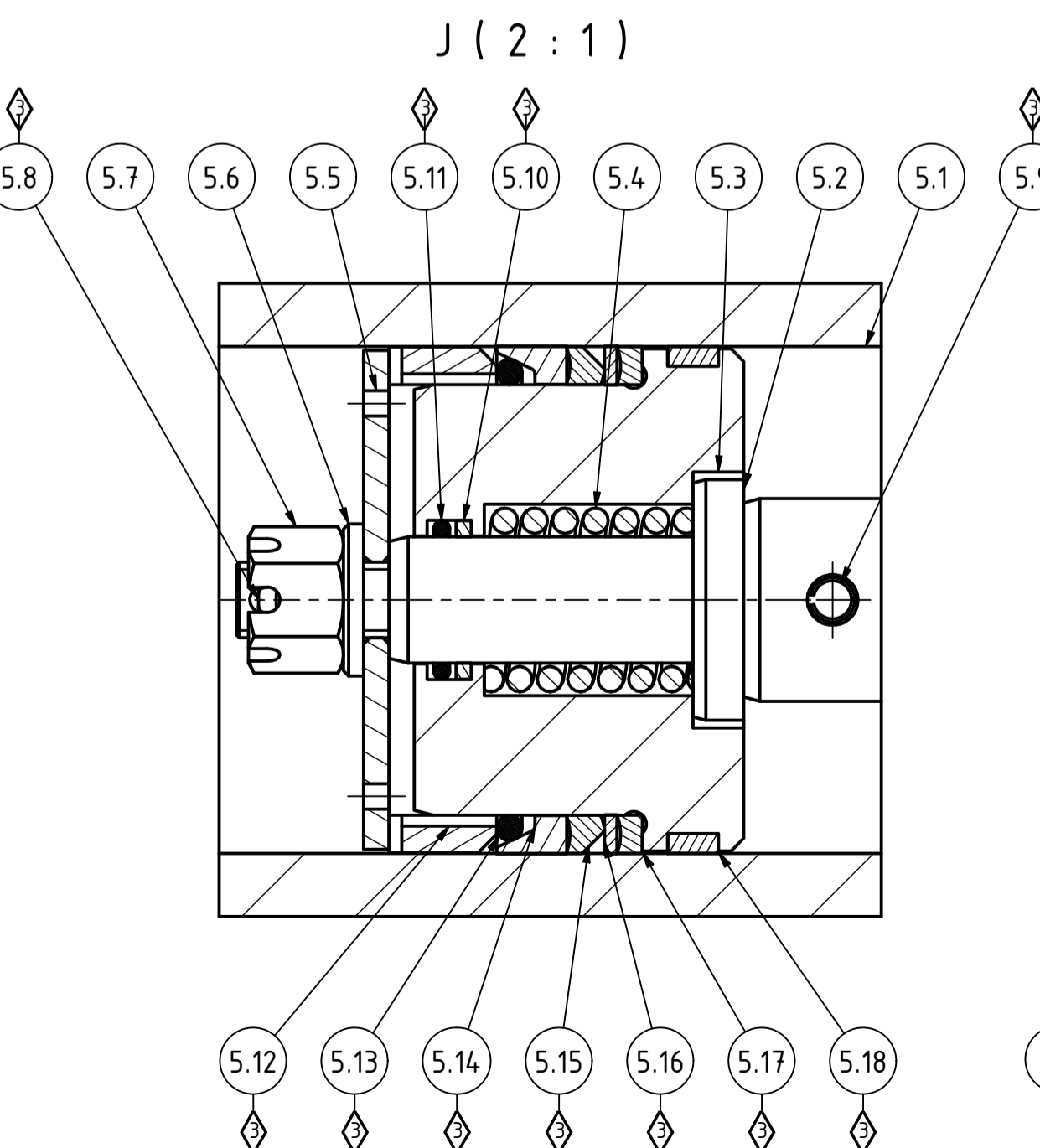
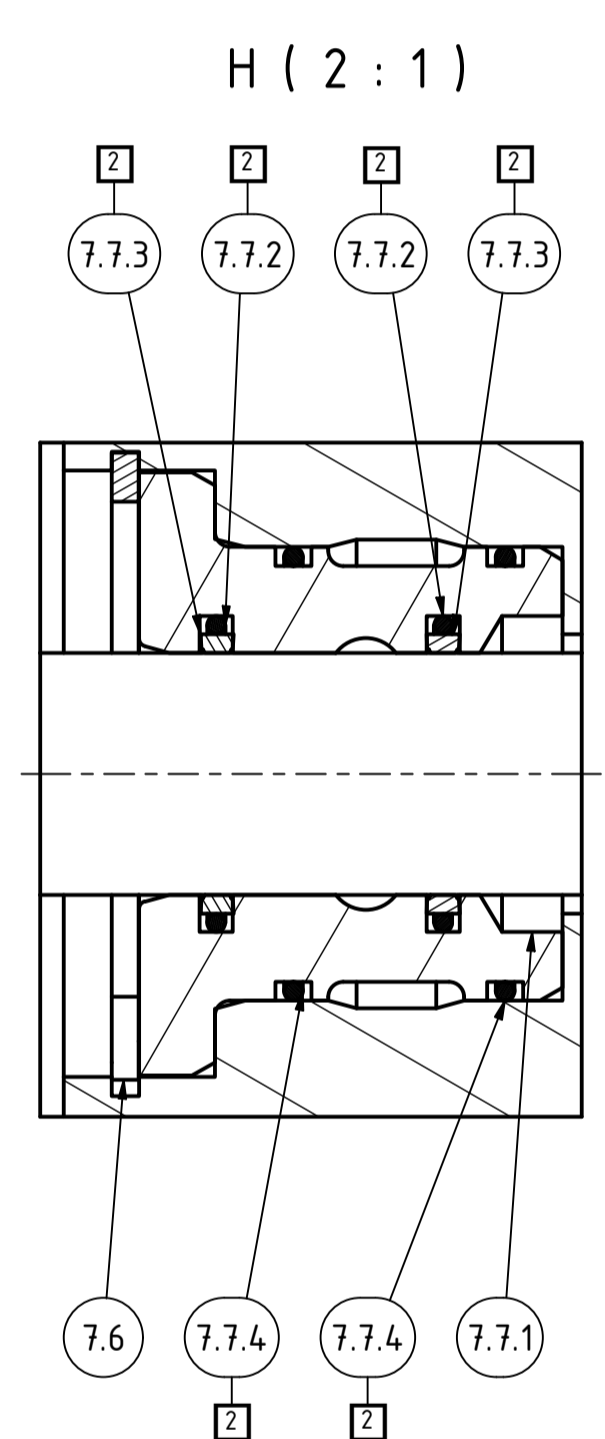
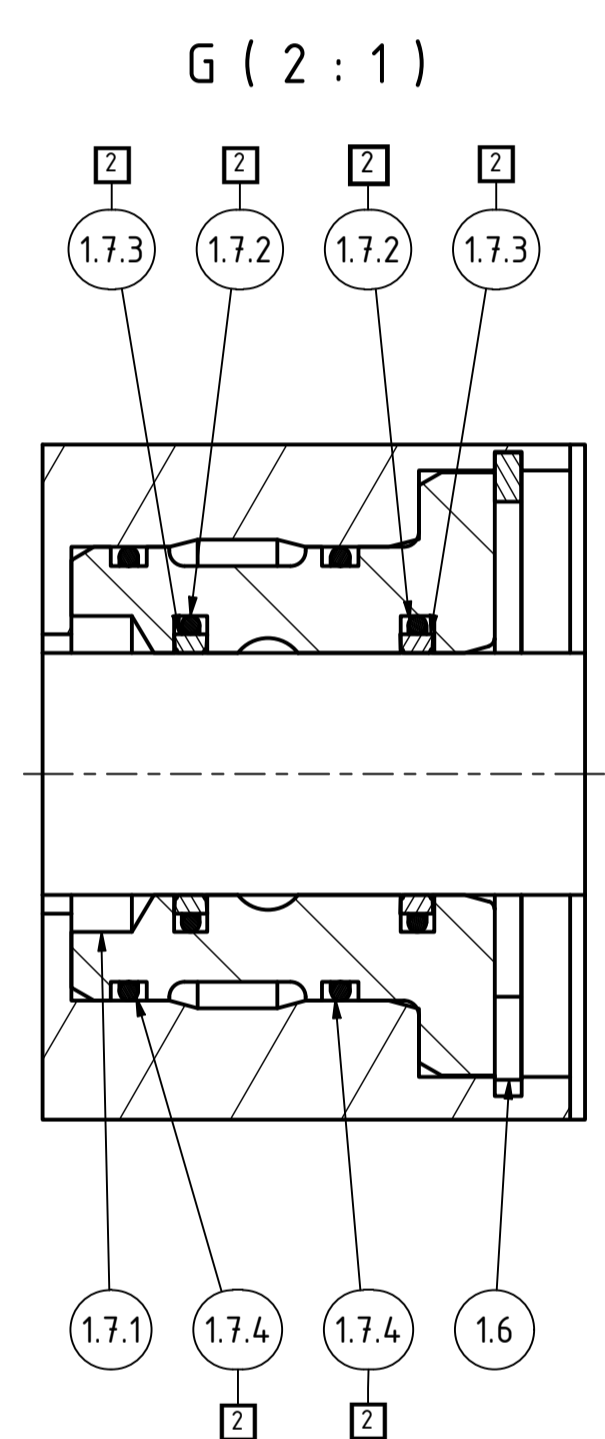
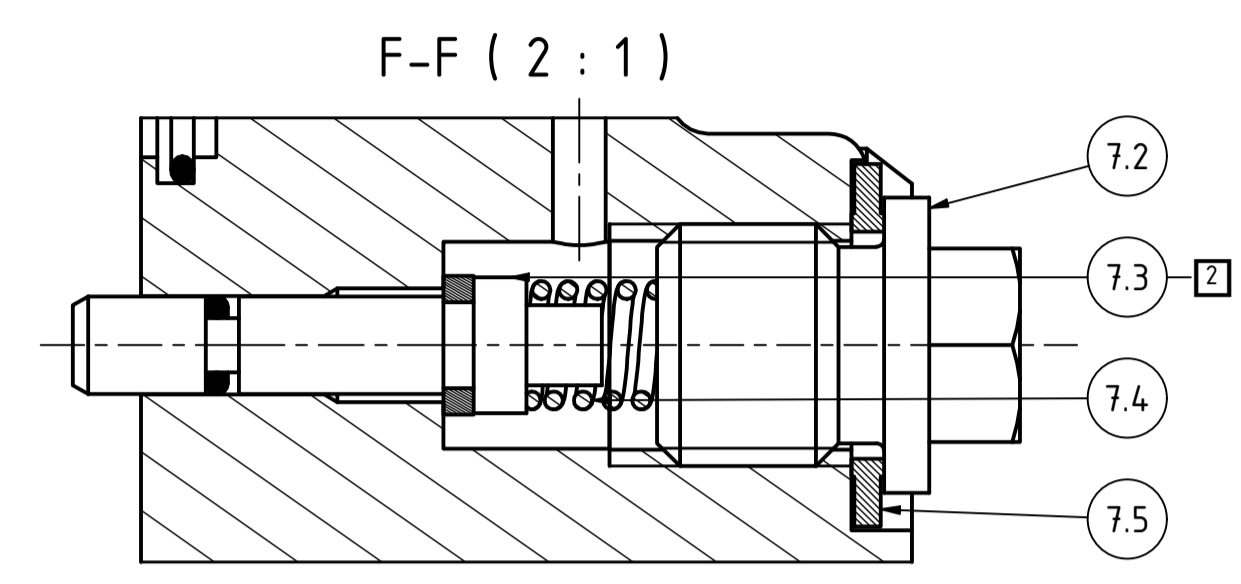
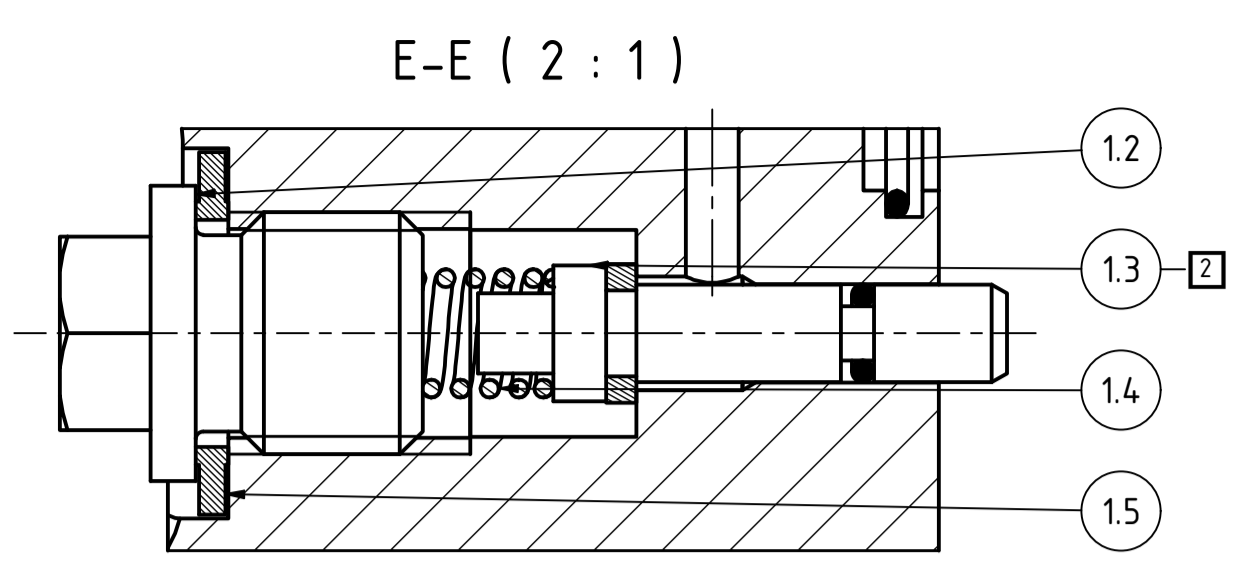

Bei Ersatzteilbestellungen Serien-Nr. angeben!
 In case of order please indicate serial-no.!

Mit Positionsnummer gekennzeichnete Teile sind verfügbar.
 Parts marked with item number are scope of supply.

- Ersatzteil Satz/Spare parts kits:**
- ▲ Steuerschieber.....3620.0102
(Seal kit spool)
 - Luftantrieb3630.0550
(Seal kit air)
 - ◇ HD-Seite.....3630.0875
(Seal kit HP)
 - Ersatzteil-Kit-Ventile.....3630.1176
(check valve sec.)

MAXIMATOR®
Typ / type: DLE 15-2-NN-M
 Art.-Nr. / Item No.: 3250.0332
 pL max.: 10bar / 145psi
 i: 1:30
 pA min.: 7bar / 102psi
 pB max.: 300bar / 4350psi
 T: -20°C ... +100°C

Bei Maßen ohne Toleranzangabe Längen- und Winkelmaße nach DIN ISO 2768-m Biege- und Schweißteile nach DIN ISO 2768-c Toleranzen für Form- und Lage nach DIN ISO 2768-K Werkstückkanten ohne Angabe nach DIN ISO 13715		MAXIMATOR®	
This document is copyright protected. Copying or editing this document is only allowed upon Maximator GmbH's written approval.		Dieses Dokument ist urheberrechtlich geschützt. Eine Vervielfältigung oder Bearbeitung des Dokuments ist nur mit schriftlicher Genehmigung der Maximator GmbH erlaubt.	
Maßstab/Scale: 1 : 2	Gewicht/Weight: 25,33 kg	Format/Sheet: A1	Blatt/Sheet: 2 / 3
g/jr/ty Datum/Date Name (Benennung/Titel) Erste: 25.07.2016 Stübmann Bearb.: 27.09.2022 TKunze Gepr.: 27.09.2022 SuSchiele	DLE 15-2-NN-M DLE 15-2-NN-M		
Werkstoff: raw material: VP16.00.1105	(Zeichnungsnummer/drawing number) C B250.0332		
Urspr.: VP16.00.1094	Ers.f./replaces: 25.05/26.05	Ers.d./replaces by:	

Stückliste / Bill of material								Stückliste / Bill of material							
Pos./Item.	Anz./Qty.	Bezeichnung	Description	Art. Nr./Order-No.	Material	Werkstoff	Bemerkung / Remark	Pos./Item.	Anz./Qty.	Bezeichnung	Description	Art. Nr./Order-No.	Material	Werkstoff	Bemerkung / Remark
1	1	Oberkappe kplf. DLE 15(30)(75) (N) 10/17	Top cap cplf.	3630.4101				7	1	Unterkappe kplf. DLE15(30)(75) (N) 10/17	Bottom cap cplf.	3630.4102			
1.1	1	Oberkappe DLE 15(30)(75)-NPT	Top cap	3630.1562				7.1	1	Unterkappe DLE 15(30)(75) (NPT)	Bottom cap	3630.1550			
1.1.1	1	Oberkappe DLE 15(30)(75)-NPT	Top cap	3630.1562	Cast Aluminum	3.4311.01		7.1.1	1	Unterkappe DLE 15(30)(75) (NPT)	Bottom cap	3630.1550	Cast Aluminum	3.4311.01	
1.1.2	4	Gewindeinsatz ENSAT M8	Threaded insert	3630.0318	Steel 8 z.p.	Stahl 8 verz.		7.1.2	4	Gewindeinsatz ENSAT M8	Threaded insert	3630.0318	Steel 8 z.p.	Stahl 8 verz.	
1.2	1	Pilotventilschraube G ... L (DLE ...) -VA	Pilot valve screw	3620.0129	303	1.4305	10 Nm	7.1.3	1	Kugel ø 4 mm (Messing)	Ball	3610.2972	Brass	Messing	
1.3	1	Pilotventilstößel kplf. G (S) (DLE) - NBR	Pilot valve tappet cplf.	3620.4103				7.2	1	Pilotventilschraube G ... L (DLE ...) -VA	Pilot valve screw	3620.0129	303	1.4305	10 Nm
1.3.1	1	Pilotventilstößel (POM) G ... L(DLE)	Pilot tappet	3620.4087	POM	POM		7.3	1	Pilotventilstößel kplf. G (S) (DLE) - NBR	Pilot valve tappet cplf.	3620.4103			
1.3.2	1	Dichtring für 3610.3180	Sealing ring	3610.3181	PUR	PUR		7.3.1	1	Pilotventilstößel (POM) G ... L(DLE)	Pilot tappet	3620.4087	POM	POM	
1.3.3	1	O-Ring 3,2 x 1,8 NBR 70	O-Ring 3,2 x 1,8 NBR 70	3660.1006	NBR	NBR		7.3.2	1	Dichtring für 3610.3180	Sealing ring	3610.3181	PUR	PUR	
1.4	1	Druckfeder	Spring	3620.0132	301	1.4310		7.3.3	1	O-Ring 3,2 x 1,8 NBR 70	O-Ring 3,2 x 1,8 NBR 70	3660.1006	NBR	NBR	
1.5	1	Usit-Ring	Gasket	3620.0131	NBR+Steel z.p.	NBR+Stahl verz.		7.4	1	Druckfeder	Spring	3620.0132	301	1.4310	
1.6	1	Sicherungsring	Snap ring	3630.0407	Stainless Steel	1.4122		7.5	1	Usit-Ring	Gasket	3620.0131	NBR+Steel z.p.	NBR+Stahl verz.	
1.7	1	Lagerbuchse kplf. DLE (NBR)	Seal housing compl.	3630.0126				7.6	1	Sicherungsring	Snap ring	3630.0407	Stainless Steel	1.4122	
1.7.1	1	Lagerbuchse POM	Seal housing	3630.0395	POM	POM		7.7	1	Lagerbuchse kplf. DLE (NBR)	Seal housing compl.	3630.0126			
1.7.2	2	O-Ring 2-017 NBR 70	O-Ring 2-017 NBR 70	3660.0112	NBR	NBR		7.7.1	1	Lagerbuchse POM	Seal housing	3630.0395	POM	POM	
1.7.3	2	Gleitring	Glide ring	3630.0406	PTFE + carbon	PTFE + Kohle		7.7.2	2	O-Ring 2-017 NBR 70	O-Ring 2-017 NBR 70	3660.0112	NBR	NBR	
1.7.4	2	O-Ring 2-022 NBR 70	O-Ring 2-022 NBR 70	3660.0118	NBR	NBR		7.7.3	2	Gleitring	Glide ring	3630.0406	PTFE + carbon	PTFE + Kohle	
1.8	1	O-Ring 155x2 NBR 70	O-Ring 155x2 NBR 70	3660.0181	NBR	NBR		7.7.4	2	O-Ring 2-022 NBR 70	O-Ring 2-022 NBR 70	3660.0118	NBR	NBR	
1.9	1	Flachdichtung DLE 15(30,75) / PTFE	Gasket	3630.3739	PTFE	PTFE		7.8	1	O-Ring 155x2 NBR 70	O-Ring 155x2 NBR 70	3660.0181	NBR	NBR	
1.10	1	Schalldämpfer G1/8" a	Muffler G1/8" a	3610.1457	PE	PE		7.9	1	Flachdichtung DLE 15(30,75) / PTFE	Gasket	3630.3739	PTFE	PTFE	
2	1	Steuerschieber kplf. DLE ... - 2 (N)	Spool valve compl. DLE...-2(N)	3630.0821				7.10	1	Schalldämpfer G1/8" a	Muffler G1/8" a	3610.1457	PE	PE	
2.1	1	Steuerschiebergehäuse DLE ...-2 (1/2NPT)	Spool valve housing	3630.0822	A92007	3.1645		8	2	Kompressorkopf kplf. DLE 15-NN (11/2017)	Check body cplf.	3630.4109			
2.2	1	Steuerschieberhülse kplf. (Baugruppe) G.	Spool valve housing cplf.	3620.4467				8.1	1	Kompressorkopf DLE 15 (1.4404lg)	Check body	3630.0866	316L	1.4404	
2.2.1	1	Steuerschieberhülse G...L	Spool valve sleeve	3620.0103	A92007	3.1645		8.2	2	Anschlussstutzen 1/4NPT (1.4305 m. 3.1)	Gland	3630.0944	303	1.4305	120 Nm
2.2.2	1	Steuerschieber G ... L (DLE ...)	Spool valve G / DLE	3620.0104	POM	POM		8.3	2	Ventilkörper DLE ... (1.4305)	Valve body	3630.0801	303	1.4305	
2.2.3	5	O-Ring 2-026 NBR 70	O-Ring 2-026 NBR 70	3660.0122	NBR	NBR		8.4	2	Ventilkugelsitz (PEEK)	Check ball seat	3610.1188	PEEK	PEEK	
2.2.4	1	O-Ring 2-023 NBR 70	O-Ring 2-023 NBR 70	3660.0119	NBR	NBR		8.5	2	Kugel ø 7,50 mm, 1.4034	Ball	3630.0872	420	1.4034	
2.2.5	5	O-Ring 9-222 NBR 80	O-Ring 9-222 NBR 80	3660.0519	NBR	NBR		8.6	2	Druckfeder Federenden angelegt	Spring	3610.1186	301	1.4310	
2.3	1	Verschlussstück (PET)	Spool plug	3620.0108	PET	PET		8.7	4	O-Ring 9-083 FKM 80	O-Ring 9-083 FKM 80	3660.0616	FKM	FKM	
2.4	1	Sicherungsring	Snap ring	3620.0113	Spring steel z.p.	Federstahl verz.		8.8	1	O-Ring 2-126 FKM 70	O-Ring 2-126 FKM 70	3660.0353	FKM	FKM	
2.5	1	O-Ring 2-026 NBR 70	O-Ring 2-026 NBR 70	3660.0122	NBR	NBR		8.9	2	Stützring PTFE DLE 15	Back up	3630.0351	PTFE	PTFE	
2.6	2	O-Ring 2-012 NBR 70	O-Ring 2-012 NBR 70	3660.0107	NBR	NBR		8.10	1	Flachdichtung DLE 15(30,75) / PTFE	Gasket	3630.3739	PTFE	PTFE	
2.7	1	O-Ring 2-008 NBR 70	O-Ring 2-008 NBR 70	3660.0103	NBR	NBR		9	1	Befestigung kplf. DLE ... -2	Mounting cplf.	3630.0598			
3	1	Luftteil kplf. DLE ... -2	Air part cplf.	3630.0595				9.1	2	Befestigungswinkel (1.4301)	Mounting bracket	3620.4230	304	1.4301	
3.1	2	Luftzylinder DLE ...	Air cylinder	3630.0174	A96060	3.3206		9.2	4	Sechskantschraube	Tie rod	3620.0743	Stainless Steel A4-70	Edelstahl A4-70	
3.2	1	Druckrohr	Pressure tube	3630.0552	316Ti	1.4571		9.3	4	Sechskantmutter	hex nut	3620.0274	Stainless Steel A2-70	Edelstahl A2-70	40 Nm
3.3	3	Luffrohr	Air tube	3630.0290	316Ti	1.4571		9.4	4	U-Scheibe	Washer	3620.0275	Stainless steel	VA	
3.4	6	O-Ring 9-161 NBR 70	O-Ring 9-161 NBR 70	3660.0184	NBR	NBR		9.5	4	Sperrkantenring 1.4310	Spring washer	3620.0276	301	1.4310	
3.5	2	O-Ring 2-009 NBR 70	O-Ring 2-009 NBR 70	3660.0104	NBR	NBR		9.6	4	Zylinderschraube mit Innensechskant	Cap screw	3620.0111	Stainless Steel A2-70	Edelstahl A2-70	8 Nm
4	2	Luftkolben kplf. DLE	Air piston cplf.	3630.0274				10	2	Befestigung kplf. KKDLE 15-75	Mounting cplf.	3630.0322			
4.1	1	Luftkolben m. Kolbenstangenhalter DLE ...	Air piston with holder	3630.0167				10.1	4	Stehbolzen (M8x218, verz.)	Tie rod	3630.0294	4140 z.p.	1.7225 verz.	
4.1.1	1	Luftkolben DLE (3.1645)	Air piston	3630.5468	A92007	3.1645	Loctite 270	10.2	4	Sechskantmutter	Hexagon nut	3630.0307	Steel 8 z.p.	Stahl 8 verz.	35 Nm
4.1.2	1	Kolbenstangenhalter DLE ...	Plunger gland	3630.0173	430F	1.4104	Loctite 270	10.3	4	Sperrkantenring DIN17221 VSK8	Spring washer	3630.0298	Spring steel z.p.	Federstahl verz.	
4.1.3	1	Sicherungsring	Snap ring	3630.0190	Stainless Steel	1.4122		11	1	Kühlung kplf. DLE 15(30,75)-2 (06/2017)	Cooling cplf.	3630.3972			
4.2	1	Bolzen mit Kopf (Splintloch)	Pin	3630.0191	Stainless steel	VA		11.1	1	Kühlleitung DLE 15(30)(75)-2	Cooling tube	3630.0576			
4.3	1	Bolzen mit Kopf (Splintloch)	Pin	3630.0192	Stainless steel	VA		11.1.1	1	Kühlleitung	Cooling tube	3630.4697	C12200	2.0090	
4.4	2	Splint	Cotter pin	3630.0193	304	1.4301		11.1.2	2	Überwurfm.-Schneidring-Einheit	Gland nut - cutting ring unit	3630.0359	Brass	Messing	
4.5	1	O-Ring 2-437 NBR 70	O-Ring 2-437 NBR 70	3660.0216	NBR	NBR		11.2	1	Rohrwinkel DLE kplf.	Air barrel cplf.	3630.3843			
5	2	HD-Kolben kplf. DLE 15(-2)-FKM	Plunger assembly	3630.0277				11.2.1	1	Rohrwinkel DLE	Air barrel	3630.3842	C12200	2.0090	
5.1	1	Druckzylinder DLE 15	Gas cylinder DLE 15	3630.0333	17-4PH Cond.H900	1.4542 Cond.H900		11.2.2	2	Überwurfm.-Schneidring-Einheit	Gland nut - cutting ring unit	3630.0359	Brass	Messing	
5.2	1	Zentrierkolben DLE 15(30) m. Splintloch	Plunger end	3630.0227	303	1.4305		11.3	2	Kühlzylinderrohr DLE 15,30,75	Cooling barrel	3630.3742	A96060	3.3206	
5.3	1	Führungskolben	Guide Plunger	3630.0242	303	1.4305		11.4	4	Einschraubverschraubung	Adapter	3630.0371	C38500	2.0401	30 Nm
5.4	1	Druckfeder	Pressure spring	3630.0237	301	1.4310		11.5	1	Winkel 90° 1/2" IA MSV VPE 80Stk.	Angle	3630.3929	Brass nickel plated	Messing vernickelt	Loctite 243
5.5	1	Scheibe	Washer	3630.0251	303	1.4305		12	2	Kolbenstange DLE15(30)(75)	Piston rod	3630.0244	440B	1.4112	
5.6	1	U-Scheibe	U Washer	3610.0185	Stainless Steel A2	Edelstahl A2		13	1	Kolbenstange DLE ... - 2	Piston rod	3630.0551	440B	1.4112	
5.7	1	Kronenmutter, hohe Form	Castle nut	3630.0270	Stainless Steel A2-70	Edelstahl A2-70		14	2	Distanzscheibe DLE 15	Distance washer	3630.1442	A92007	3.1645	
5.8	1	Splint	Cotter pin	3630.0271	Stainless Steel A2	Edelstahl A2		15	2	O-Ring 2-029 FKM 70	O-Ring 2-029 FKM 70	3660.0280	FKM	FKM	
5.9	1	Spannstift	Roll pin	1700.1315	Spring steel	Federstahl		16	2	O-Ring 2-029 FKM 70	O-Ring 2-029 FKM 70	3660.0280	FKM	FKM	
5.10	1	Stützring DLE 15(30)	Back up	3630.0195	PTFE	PTFE		17	1	Schalldämpfer G 1/2"	Muffler 1/2" BSP	3630.0104	PE	PE	
5.11	1	O-Ring 5-212 FKM 75	O-Ring 5-212 FKM 75	3660.0401	FKM	FKM		18	2	O-Ring 155x2 NBR 70	O-Ring 155x2 NBR 70	3660.0181	NBR	NBR	
5.12	1	Spannelement DLE 15	Spacer	3630.0249	PTFE + carbon	PTFE + Kohle									
5.13	1	O-Ring 9-318 FKM 90	O-Ring 9-318 FKM 90	3660.0536	FKM	FKM									
5.14	1	Kolbendichtring DLE 15	Seal	3630.0248	PTFE	PTFE									
5.15	1	Stützscheibe DLE 15	Packing washer	3630.0247	C63000	2.0966									
5.16	1	Dichtscheibe DLE 15	Packing ring	3630.0246	PTFE	PTFE									
5.17	1	Stützring DLE 15	Back up	3630.0245	C63000	2.0966									
5.18	1	Kolbenführungsring	Glide ring	3630.0197	PTFE + carbon + graphite	PTFE + Kohle + Graphit									
6	1	Zwischenkappe kplf. DLE ... -2	Air separation cap cplf.	3630.3470											
6.1	1	Zwischenkappe DLE...-2	Air separation cap	3630.3456	A92007	3.1645									
6.2	1	Anflanschblock DLE...-2	Air block	3630.3457	A96012	3.0615									
6.3	2	Zylinderschraube mit Innensechskant A4-70	Cylinder head screw	3504.1424	Stainless Steel A4-70	Edelstahl A4-70	8 Nm								
6.4	2	Gleitring	Glide ring	3630.0406	PTFE + carbon	PTFE + Kohle									
6.5	2	Stangenführungsring	Guide ring	3440.0969	PTFE + carbon + graphite	PTFE + Kohle + Graphit									
6.6	2	O-Ring 2-017 NBR 70	O-Ring 2-017 NBR 70	3660.0112	NBR	NBR									
6.7	2	O-Ring 2-017 NBR 70	O-Ring 2-017 NBR 70	3660.0112	NBR	NBR									
6.8	1	Schalldämpfer G1/8"	Exhaust BSP1/8"	3509.5545	Sintered bronze	Sinterbronze									

Bei Maßen ohne Toleranzangabe Längen- und Winkelmaße nach DIN ISO 2768-m Biege- und Schweißteile nach DIN ISO 2768-c Toleranzen für Form- und Lage nach DIN ISO 2768-K Werkstückkanten ohne Angabe nach DIN ISO 13715



This document is copyright protected. Copying or editing this document is only allowed upon Maximator GmbH's written approval.

Dieses Dokument ist urheberrechtlich geschützt. Eine Vervielfältigung oder Bearbeitung des Dokuments ist nur mit schriftlicher Genehmigung der Maximator GmbH erlaubt.

Maßstab: Scale: Gewicht: Weight: Format: A2 Blatt 3 / 3

01/19	Datum/Date	Name	(Benennung/Title)
Erste	25.07.2016	SFührmann	DLE 15-2-NN-M
Bearb.	27.09.2022	TKunze	
Gepr.	27.09.2022	SuSchiele	DLE 15-2-NN-M

Freigegeben

Halbzeug: raw material: (Zeichnungsnummer/drawing number) Rev. (Artikel-Nr./order number)

Werkstoff: basic material: VP16.00.1105 C 3250.0332

Urspr.: VP16.00.1094 Ers.f./replaces: 25.05/216.05 Ers.d./replac.by: