

MAXIMATOR® US

MAXPRO Technologies

Technical Data Sheet

Gas booster DLE 5-2

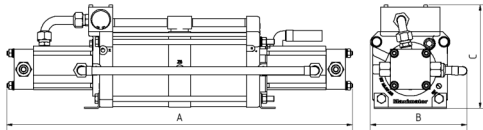
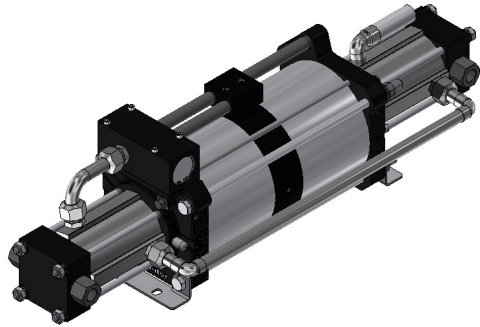

DLE 5-2
double acting, double air drive head
single stage

Technical Data:

Air drive pressure pL:	1 - 10 bar / 14.5 - 145 psi
Pressure ratio i:	1:10
Compression ratio:	1:50
Minimum suction pressure pA:	73 psi
Maximum suction pressure pA:	1450 psi
Maximum outlet pressure pB:	1450 psi
Displacement volume/double stroke:	45.5 in ³
Maximum cycles:	100/min
Stall pressure:	$p_B = i * p_L + p_A$

Standard Connections:

Air drive:	1/2" NPT
DLE 5-2 (-NN):	Inlet/Outlet: 1/2" NPT
Maximum operating temperature:	140°F
Net weight:	55 LBS

Pressure and flow performances, please see enclosed graph.

Materials of construction hp section DLE 5-2:

Standard seal package:	PTFE, FKM
Compressor head:	3.1645
HP cylinder:	1.4404
HP piston:	1.4305
Fittings:	1.4404
Balls:	1.4034
Springs:	1.4310

Approximate Dimensions:

A:	30.94"
B:	8.65"
C:	9.17"

Available Options:

Inert gas service (standard):	DLE 5-2 (-NN)
Oxygen service:	DLE 5-2-NN-S-M
CO ₂ service:	DLE 5-2-NN-C-M
In-/Outlet: 3/8" NPT:	DLE 5-2-NN-M

Available Accessories:

Air control units with filter pressure regulator, control pressure gauge and shut off valve:	DLE 5-2 with ACP
To protect the booster against excessive outlet pressures or to limit the outlet pressure, a safety valve can be fitted to the air control unit in the air drive line.	DLE 5-2 with ACP-RV-air (The required outlet pressure has to be indicated.)

Please consult factory for more information. All technical and dimensional information subject to change. All General Terms and Conditions of sale, including limitations of our liability, apply to all products and services sold.

