

NOTE: THIS DRAWING OR PRINT, PROPERTY OF MP PUMPS INC., CONTAINS PROPRIETARY AND CONFIDENTIAL INFORMATION. IT SHALL BE USED ONLY AS APPROVED BY MP PUMPS AND SHALL NOT BE GIVEN TO OTHERS OR COPIED WITHOUT THE WRITTEN CONSENT OF MP PUMPS. RETURN TO MP PUMPS PROMPTLY WHEN REQUESTED.

G						UNLESS OTHERWISE NOTED THIRD ANGLE PROJECTION 2 PLACE DIM \pm .020 3 PLACE DIM \pm .010 ANGULAR DIM \pm 1°	MP PUMPS, INC. FRASER, MICHIGAN 48026, U.S.A.					
F					MATERIAL					MATERIAL SPECS		
E							DRAWN BY	DATE COMP.	APPROV.	SCALE	MADE FOR	MADE FROM
D							S.F.	4/4/17	D.D.			
C							DO NOT SCALE					
B						NAME PO8PPK C:CCMTR 7/8 5.0 T-21 NRS					DRAWING NO	
A											36171	
REV	DESCRIPTION	DRAWN	DATE	EN								

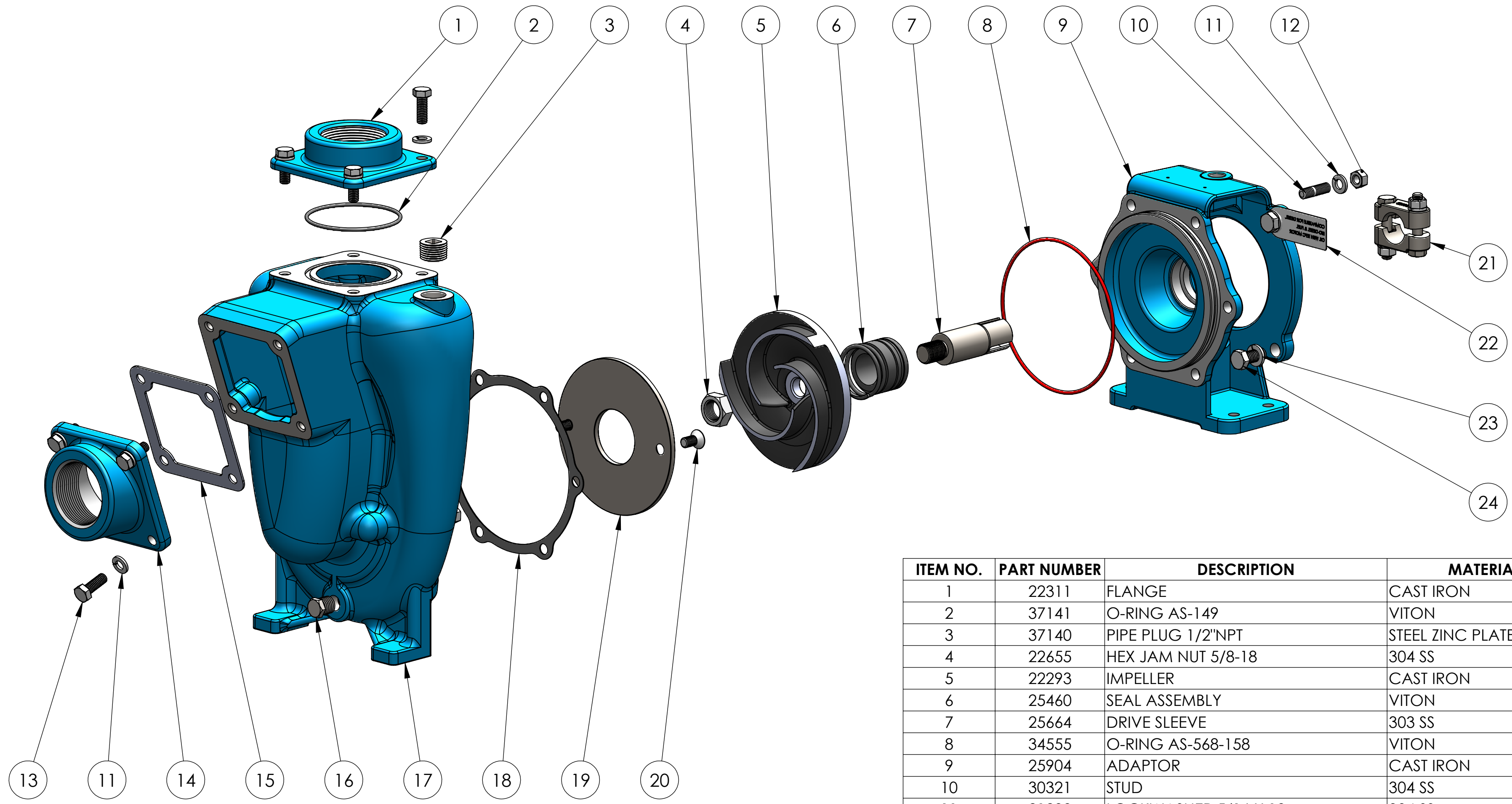

ITEM NO.	PART NUMBER	DESCRIPTION	MATERIAL	QTY.
1	22311	FLANGE	CAST IRON	1
2	37141	O-RING AS-149	VITON	1
3	37140	PIPE PLUG 1/2"NPT	STEEL ZINC PLATED	1
4	22655	HEX JAM NUT 5/8-18	304 SS	1
5	22293	IMPELLER	CAST IRON	1
6	25460	SEAL ASSEMBLY	VITON	1
7	25664	DRIVE SLEEVE	303 SS	1
8	34555	O-RING AS-568-158	VITON	1
9	25904	ADAPTOR	CAST IRON	1
10	30321	STUD	304 SS	6
11	21238	LOCKWASHER 5/16 X 18	304 SS	16
12	21284	HEXNUT 5/16-18X1/2	304 SS	8
13	21242	CAP SCREW HH 5/16-18 X 7/8	304 SS	8
14	22387	SUCTION FLANGE	CAST IRON	1
15	35609	GASKET	CORK/BUNA	1
16	21267	PIPE PLUG HH 1/4 NPT	316 SS	1
17	22251	HOUSING	CAST IRON	1
18	35722	GASKET	KINGERSIL	1
19	22260	WEAR PLATE	STEEL	1
20	37137	SCREW FHS 5/16-18 X 5/8	304 SS	2
21	23003	CLAMP ASSEMBLY	303 SS	1
22	35682	NAME PLATE	304 SS	1
23	21266	LOCKWASHER 3/8 X 1/8	304 SS	4
24	21251	CAPSCREW: 3/8-16X7/8	304 SS	4

NOTE: THIS DRAWING OR PRINT, PROPERTY OF MP PUMPS INC., CONTAINS PROPRIETARY AND CONFIDENTIAL INFORMATION. IT SHALL BE USED ONLY AS APPROVED BY MP PUMPS AND SHALL NOT BE GIVEN TO OTHERS OR COPIED WITHOUT THE WRITTEN CONSENT OF MP PUMPS. RETURN TO MP PUMPS PROMPTLY WHEN REQUESTED.

G					UNLESS OTHERWISE NOTED THIRD ANGLE PROJECTION 2 PLACE DIM ± .020 3 PLACE DIM ± .010 ANGULAR DIM ± 1°	MP PUMPS, INC. FRASER, MICHIGAN 48026, U.S.A.					
F											
E											
D											
C											
B					DO NOT SCALE	DRAWN BY	DATE COMP.	APPROV.	SCALE	MADE FOR	MADE FROM
A						S.F.	4/4/17	D.D.			
REV	DESCRIPTION	DRAWN	DATE	EN	NAME	DRAWING NO					
					PO8PPK C:CCMTR 7/8 5.0 T-21 NRS	36171					