

Gas Ball Valve



2 Piece • Male Dielectric Union End x Flare Connections • 600 WOG



T-204DU MIP x FL

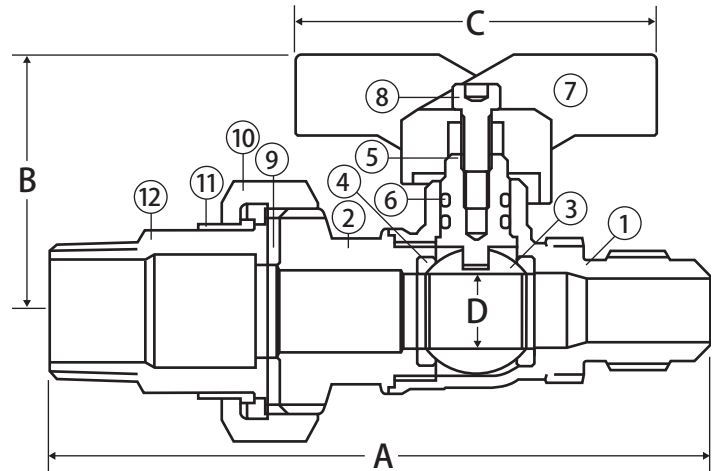

Features

- Meets the NFPA 58 dielectric requirement
- Valve can be locked in the closed position by reversing the handle
- 2 FKM o-rings
- 100% leak tested
- 100% Made in Italy
- Leakproof stem - Lifetime Warranty

Approvals

- CSA Certified
 - ANSI Z21.15 (.5 PSIG) (1/2")
 - ASME B16.44 (5 PSI) (1/2")
 - CGA CR91 (5 PSIG) (1/2")
- ANSI B1.20.1
- Meets or exceeds applicable part of UL: YSDT - LP Gas Shut-off valves (600PSI)
- MSS SP-110
- Flare Connection in accordance with NFPA 54/ANSI Z223.1

Material Specifications

No.	Part	Materials
1	Body	Brass - CW617N
2	End Connection	Brass - CW617N
3	Ball	Chrome Plated Brass - CW614N
4	Seat (2)	PTFE
5	Stem	Brass - CW614N
6	Stem O-ring (2)	FKM
7	Handle	Aluminum
8	Handle Screw	Steel - Geomet® Plated
9	Gasket	Buna-N
10	Union Nut	Brass - CW617N
11	Dielectric Ring	Nylon 6
12	Tail Piece	Brass - CW614N

Dimensions

Part No.	Size	A	B	C	D
101-703DU	1/2" MIP x 1/2" FL	4.32	1.63	2.32	0.47
101-704DU	3/4" MIP x 5/8" FL	4.77	1.75	2.32	0.59

Valve Seat Rating 600 WOG

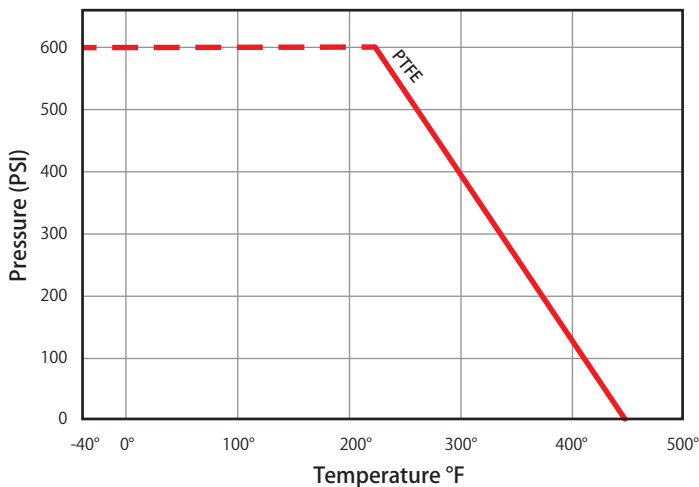

WARNING: This product can expose you to chemicals including lead, which is known to the State of California to cause cancer, and lead, which is known to the State of California to cause birth defects or other reproductive harm. For more information go to www.P65Warnings.ca.gov.

