

Gas Ball Valve



2 Piece • Male Dielectric Union End x Flare Connection • 600 WOG • with Side Tap



T-203DU MIP x FL

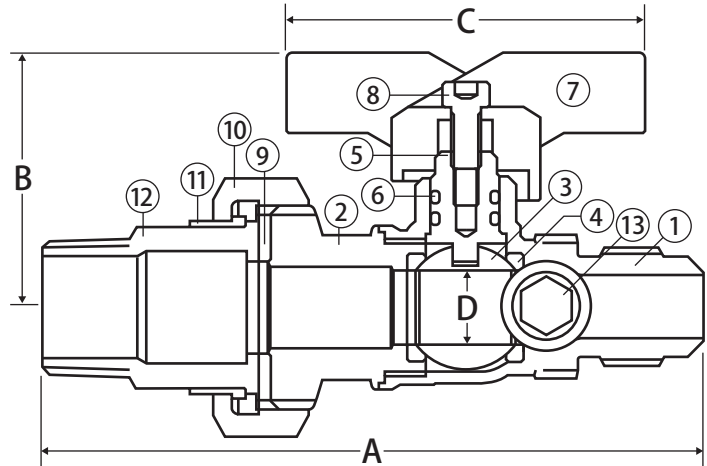

Features

- Meets the NFPA 58 dielectric requirement
- Eliminates need for test tee and labor to install
- Removable plug enables port for pressure gauge
- Valve can be locked in the closed position by reversing the handle
- 2 FKM o-rings
- 1/8" side tap
- 100% leak tested
- 100% Made in Italy
- Leakproof stem - Lifetime Warranty

Approvals

- CSA Certified
 - ANSI Z21.15 (.5 PSIG)
 - ASME B16.44 (5 PSI)
 - CGA CR91 (5 PSIG)
- ANSI B1.20.1
- Meets or exceeds applicable part of UL: YSDT - LP Gas Shut-off valves (600PSI)
- MSS SP-110
- Flare Connection in accordance with NFPA 54/ANSI Z223.1

Valve Seat Rating

600 WOG

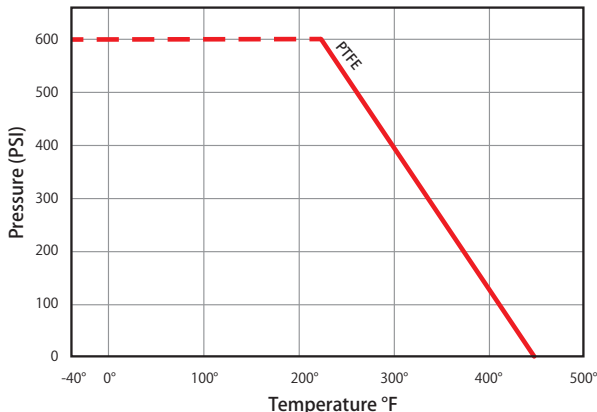

Material Specifications

| No. | Part | Materials |
|-----|-----------------|------------------------------|
| 1 | Body | Brass - CW617N |
| 2 | End Connection | Brass - CW617N |
| 3 | Ball | Chrome Plated Brass - CW614N |
| 4 | Seat (2) | PTFE |
| 5 | Stem | Brass - CW614N |
| 6 | Stem O-ring (2) | FKM |
| 7 | Handle | Aluminum |
| 8 | Handle Screw | Steel - Geomet® Plated |
| 9 | Gasket | Buna-N |
| 10 | Union Nut | Brass - CW617N |
| 11 | Dielectric Ring | Nylon 6 |
| 12 | Tail Piece | Brass - CW614N |
| 13 | Side Tap Plug | Brass - CW614N |

Dimensions

| Part No. | Size | A | B | C | D |
|-----------|--------------------|------|------|------|------|
| 102-403DU | 1/2" MIP x 1/2" FL | 4.43 | 1.63 | 2.32 | 0.47 |



WARNING: This product can expose you to chemicals including lead, which is known to the State of California to cause cancer, and lead, which is known to the State of California to cause birth defects or other reproductive harm. For more information go to www.P65Warnings.ca.gov.

