

D400 Series

pH/ORP Digital Analyzer Controller

Operating Manual



Industrial
Analytical
Equipment



Contents

Preface	3
Features.....	3
Technical Specifications.....	4
Typical Application.....	4
Instrument Connection.....	5
Dimension.....	5
Instrument Installation.....	6
Keypad Descriptions.....	7
Display Descriptions.....	8
Menu Structure.....	9
Calibration.....	10
pH Buffer Reading vs Temperature.....	12
Field Calibration.....	12
Measurement Settings (Quick Start).....	13
SimplCal® Calibration (Quick Start).....	14
Field Calibration (Quick Start).....	15
Calibration Adjustment (Quick Start).....	16
Alarm / Relay Settings (Quick Start).....	17
Output Settings (Quick Start).....	18
Measurement Settings (Quick Start).....	19
MODBUS RTU General Information.....	20
MODBUS RTU Transmission Mode.....	21
MODBUS RTU CRC Check.....	22
Implementation of MODBUS RTU in Instrument.....	22
Data Format.....	24
Read Instruction Mode.....	26
Daily Maintenance.....	26
Troubleshooting.....	27
Warranty.....	27

Preface

Please read this manual carefully before use.

When receiving the instrument, please open the package carefully, check whether the instrument and accessories are damaged by transportation and whether the accessories are complete. If any abnormalities are found, please contact our after-sales service department or regional customer service center, and keep the package for return processing.

This instrument is an analytical measurement and control instrument with highly precision. Only skilled, trained or authorized person should carry out installation, setup and operation of the instrument. Ensure that the power cable is physically separated from the power supply when connection or repair. Once the safety problem occurs, make sure that the power to the instrument is off and disconnected.

For example,

1. Apparent damage to the analyzer
2. The analyzer does not work properly or provides specified measurements
3. The analyzer has been stored for a long time in an environment where the temperature exceeds 70°C

The analyzer must be installed by licensed professionals in accordance with relevant local specifications, and instructions are included in the operation manual. Comply with the technical specifications and input requirements of the controller.

Features

The instrument is equipped with different types of pH or ORP sensors. Widely used in power plants, petrochemical industry, metallurgical electronics, mining, paper industry, biological fermentation engineering, medicine, food and beverage, environmental protection water treatment, aquaculture, modern agricultural planting and other industries. The pH (acidity and alkalinity) value, ORP (redox potential) value and temperature value of water solution were continuously monitored and controlled.

- ❑ Large LCD display
- ❑ Intelligent menu operation
- ❑ Multiple automatic calibration
- ❑ Manual + automatic temperature compensation
- ❑ Two (2) relay control switches
- ❑ 4-20mA & RS485 multiple output modes
- ❑ Multi-parameter display — simultaneously shows pH, ORP and temperature
- ❑ Password protection



Technical Specifications

Measuring Range	pH: -2 – 16pH ORP: -2000 – +2000mV
Unit	pH mV
Resolution	pH: 0.001pH ORP: 1mV
Basic Error	pH: 0.001pH ORP: 1mV
Temperature Range	14 – 302°F -10 – 150°C (Sensor Selection Dependant)
Temperature Resolution	0.18°F 0.1°C
Temperature Accuracy	±0.54°F ±0.3°C
Temperature Compensation	Manual or Automatic
Stability	pH: 0.01pH/24h ORP: 1mV/24h
Outputs	Two (2) 4–20mA 20–4mA 0–20mA
Communication	RS485 MODBUS RTU
Relay Control Contact	5A 240VAC 5A – 28VDC
Power Supply	9 – 36VDC (std) 85 – 265VAC Power Consumption 3W
Working Temperature	14 – 140°F -10 – 60°C
Relative Humidity	≤ 90%
Enclosure Rating	IP65
Weight	0.5kg
Dimensions	98 × 98 × 130mm
Installation Opening Size	93 X 93mm
Installation methods	Panel Pipe Wall

Typical Application

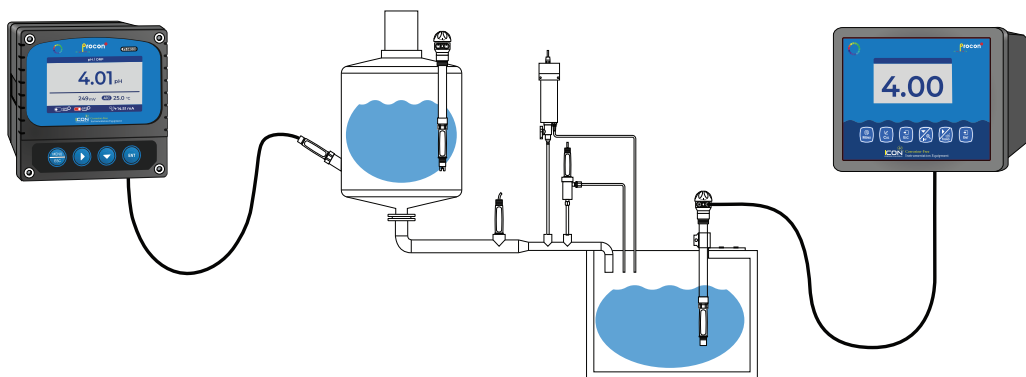

Instrument Connection

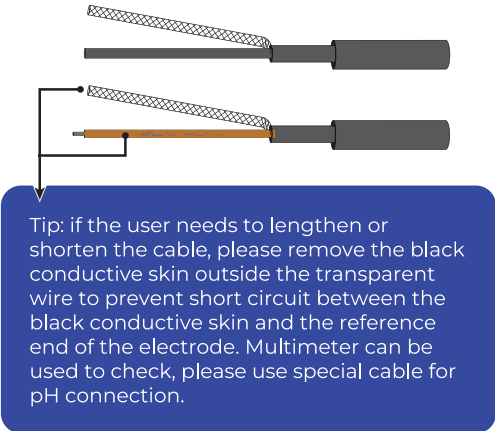
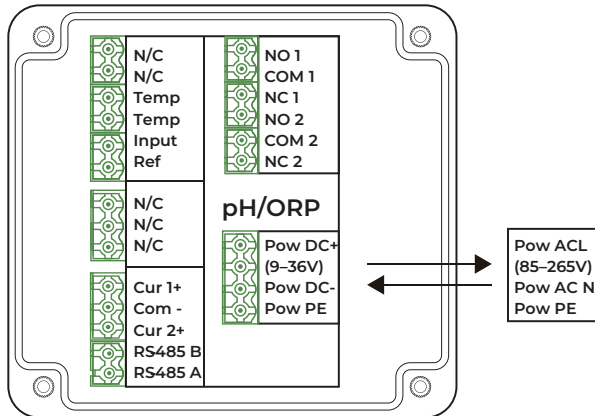

Terminal	Function
N/C	No Connection
N/C	No Connection
Temp	Temperature Sensor
Temp	Temperature Sensor
Input	Measurement
Ref	Reference
N/C	No Connection
N/C	No Connection
N/C	No Connection
Cur 1 +	Current output 1+
Com -	Current output common
Cur 2 +	Current output 2+
RS485 B	Communication Terminal
RS485 A	Communication Terminal

Terminal	Function
NO 1	High set relay working position
COM 1	Alarm relay common
NC 1	High set relay resting position
NO 2	Low set relay working position
COM 2	Alarm relay common
NC 2	Low set relay resting position
Pow DC + (9 - 36V)	DC power + (9 - 36V)
Pow DC -	DC power -
Pow PE	Earth wire
Pow ACL (85 - 265V)	Live wire
Pow AC N	Neutral wire
Pow PE	Earth wire

Dimension

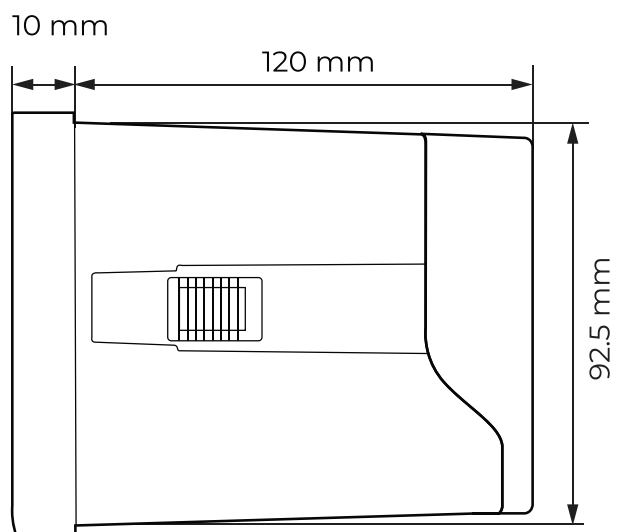
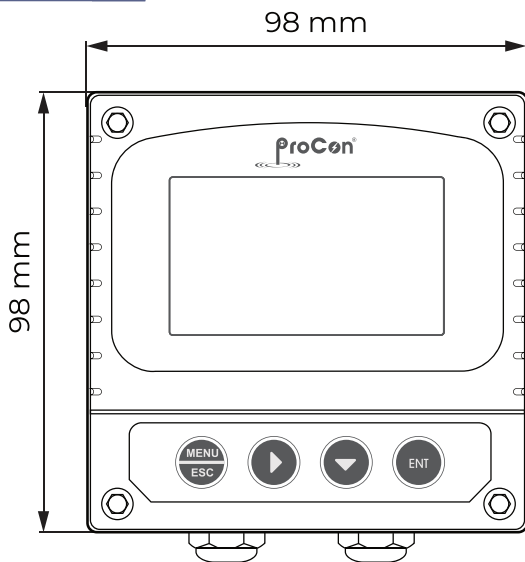

Instrument Installation

Control Panel Installation

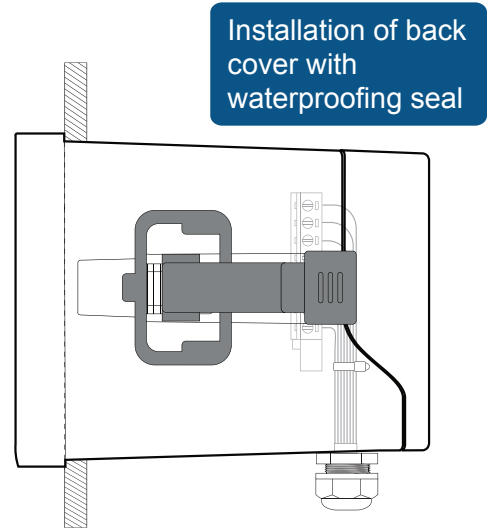
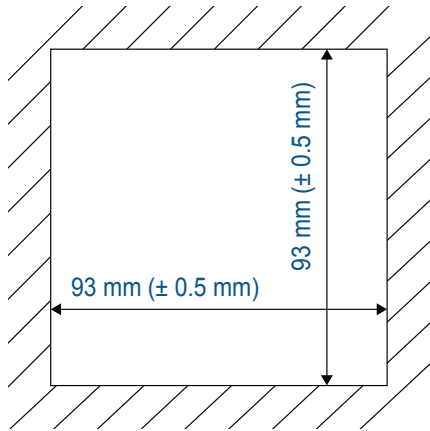

Wall Mounting

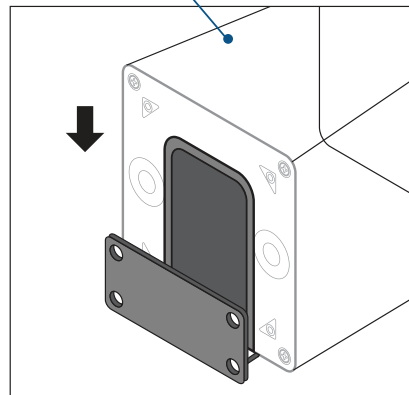
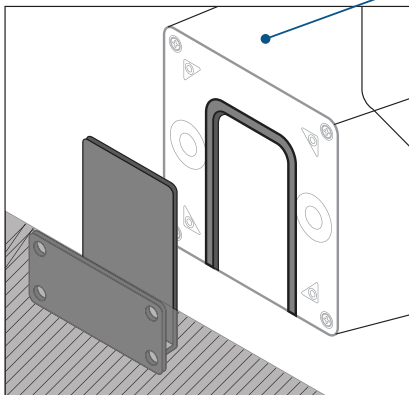
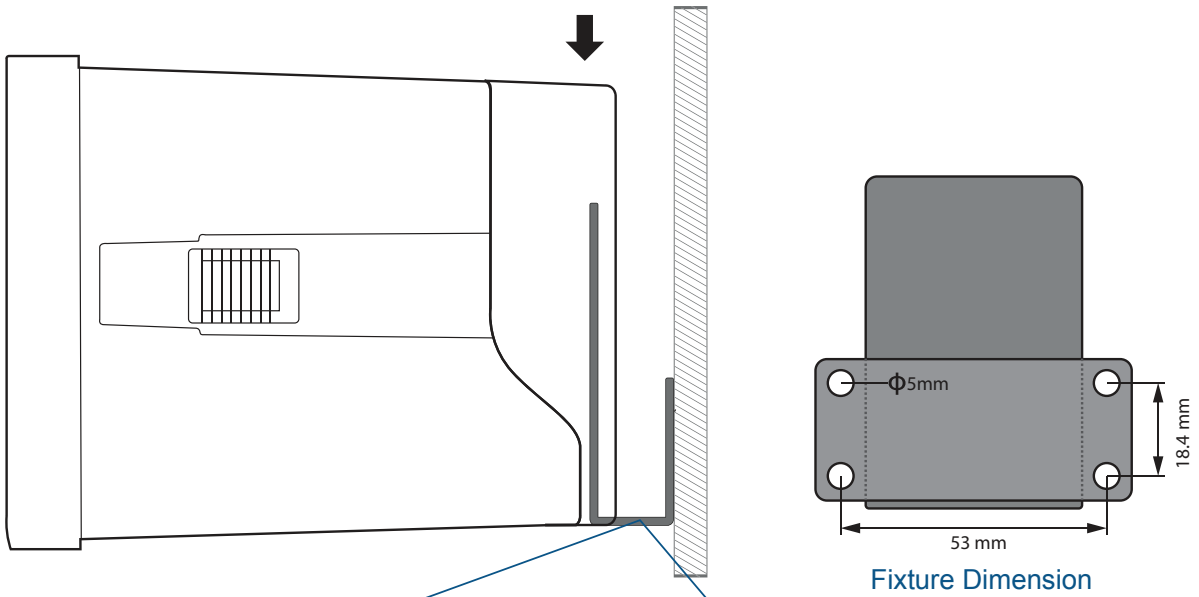

Keypad Descriptions

Press to move menu left

Confirm Options

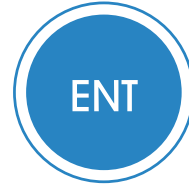

Enter menu programming menu
Return to previous menu
Long press to return the measurements screen

Menu setting mode: press this key to loop down the menu options
Value input mode: current mA / loop
In measurement mode, long press to set parameters for browsing

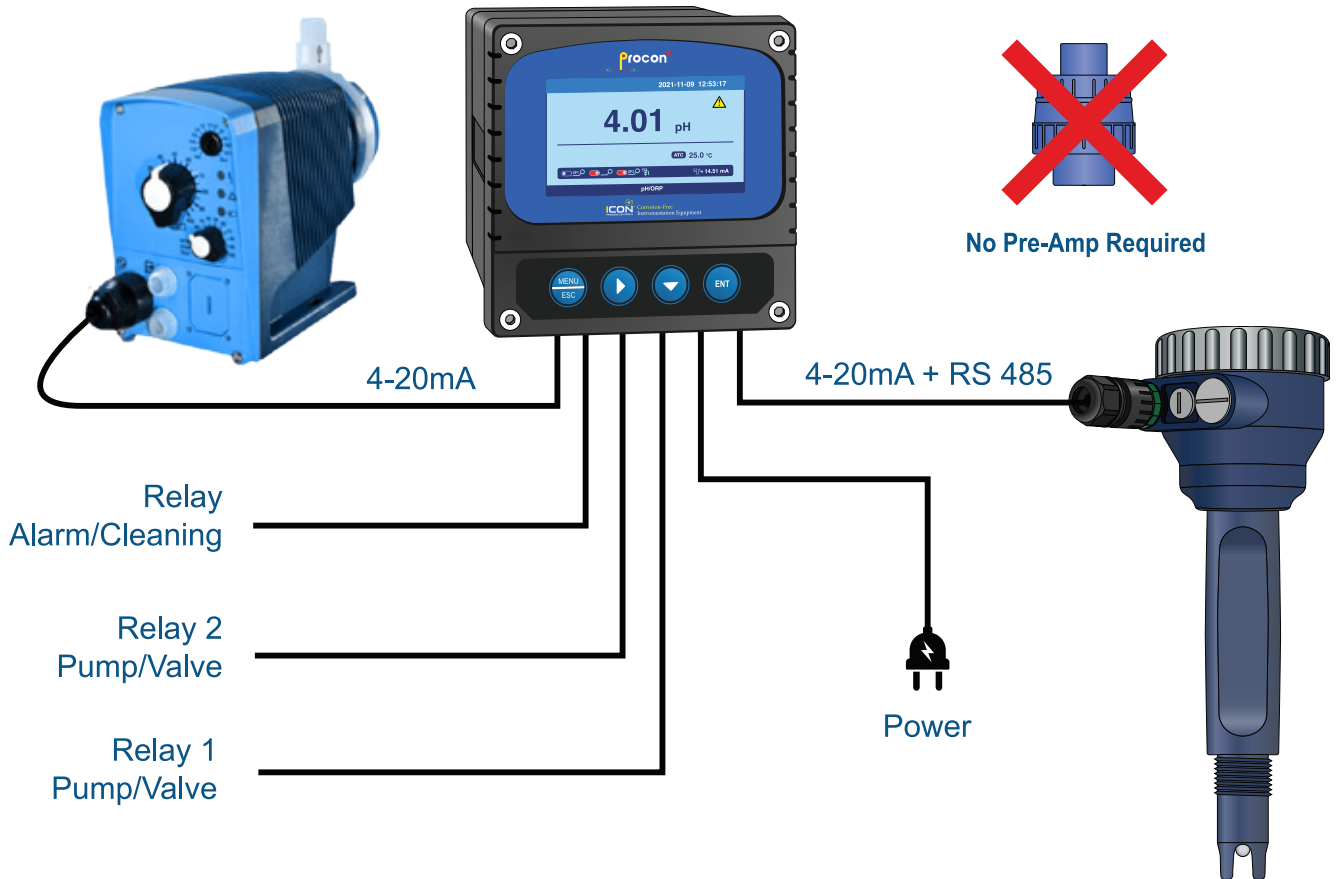

Display Descriptions

Check all pipe connections and electrical connections before use. The instrument will display as shown in the figure below after the power is turned on.

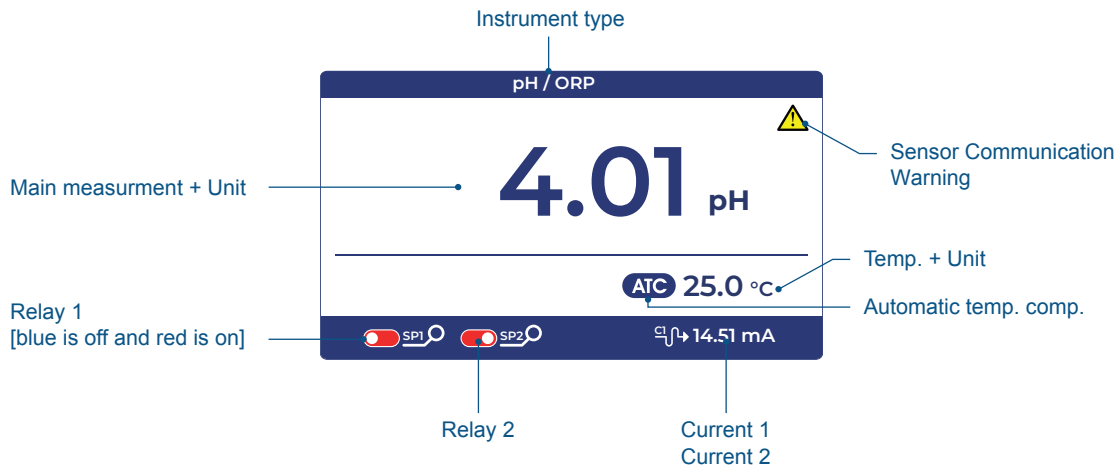

Measurement Mode



Programming Mode

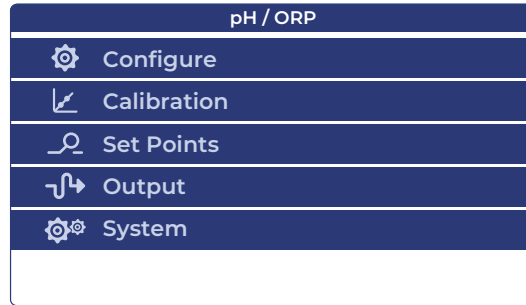





Calibration Mode



Menu Structure

Press  [MENU] key to enter programming mode:

If the monitor prompts you to enter the calibration security password, press the  or  key to set the calibration security password, and then press the  [ENT] key to confirm the calibration security password. No initial password here, please enter directly by pressing the  [ENT] key.

Item	Display	Selection	Sub Menu
Configure	Sensor	Type	pH
			ORP
		Unit	pH
			mV
	Temperature	Temperature Sensor	NTC2.252 kΩ
			NTC10 kΩ
			Pt100
			Pt1000 (Default)
		Temperature Offset	0.0000
		Temperature Input	Automatic
			Manual
		Temperature Unit	°C
°F (Default)			
Calibration	Standard Solution Calibration	USA : 7.00,4.01,10.01	
		NIST : 6.86,4.01,9.18	
		ORP Standard Solution	
	Field Calibration	Field Calibration	
		Offset Adjustment	
		Slope Adjustment	
	Calibration Adjustment	Offset Adjustment 1	
		Offset 2 Adjustment	
		Slope Adjustment 1	
Set Points	Relay 1	Status	ON
			OFF
		High/Low Setpoint	High Alarm
			Low Alarm
			Clean
		Limit Value	0.00 (Default)
	Hysteresis	00.000	
	Relay 2	Status	ON
			OFF
		High/Low Setpoint	High Alarm
			Low Alarm
			Clean
		Limit Value	0.00 (Default)
		Hysteresis	00.000

Item	Display	Selection	Sub Menu
Output	Current 1	Channel	Main
			Temperature
		Output Option	4-20mA (Default)
			0-20mA
			20-4mA
	Upper Limit	00.00	
	Lower Limit	00.00	
	Current 2	Channel	Main
			Temperature
		Output Option	4-20mA (Default)
0-20mA			
20-4mA			
Upper Limit	00.00		
Lower Limit	00.00		
Output	RS485	Baud Rate	4800BPS
			9600BPS (Default)
			19200BPS
		Parity Check	None
			Odd
			Even
		Stop Bit	1 Bit
2 BIT			
Network Node	000001		
System	Language	English	
	Date/Time	Year-Month-Day	
		Hour-Minute-Second	
	Display	Display Speed	Low
			Standard (Default)
			Medium
			High
	Backlight	Power Saving [Enter Value]	
		Long Bright	
	Information	Soft Version	19-1.0
Password Settings		0000	
Serial Number			
Factory Default	No	Keep User Settings	
	Yes	Reset back to Factory Default	

Calibration

Press  [MENU] to enter the calibration menu and select

Output	Standard Calibration	USA:7.00,4.01,10.01	Automatic Note: calibrate 7.00 first
		USA:7.00,4.01,10.01	Automatic Note: calibrate 6.86 first
		USA:7.00,4.01,10.01	235mV(Default)
	Field Calibration	USA:7.00,4.01,10.01	Enter Value
			Enter Value
		Slope Adjustment	Enter Value

Calibration of Standard Solution

Select the Standard Solution Calibration,

USA: 7.00, 4.01, 10.01

NIST: 6.86, 4.01, 9.18.

After the selection is completed, press the [ENT] button to enter the calibration mode

Submerge sensor into individual reference solutions different for 10 seconds min.

Note: begin with 7.00 USA - 6.86 NIST reference solution.

Press [ENT] button to calibrate.

The calibrated value will appear in box Move to next reference liquid and follow same procedure If the instrument has been calibrated, the calibration screen will display DONE calibrated state. If recalibration is needed, press the [ent] key in this state to enter recalibration.

If the monitor prompts you to enter the calibration password, press or key to set the calibration safety password, then press [ENT] to confirm the calibration safety password.



PH Calibration



ORP Calibration

PH Calibration: After entering the calibration mode, the instrument displays as shown above. The instrument automatically identifies the standard liquid, first calibrates the midpoint (example 7.00pH), then calibrates 4.01pH or 10.01pH. The corresponding mV value will be displayed on the left side of the screen. After the calibration is completed, the offset and slope will be displayed on the right side of the screen. The pH value of buffer solution was measured at 25°C.

To calibrate the instrument using an automatic identification buffer, you need a standard pH buffer that matches any of these values.

Before using automatic calibration, please select the correct buffer table (see "Buffer Table").

Field Calibration — Select on-site calibration methods: [Linear calibration], [Offset adjustment], [linear adjustment].

If only two points of calibration are needed, after two points of calibration, press the



[MENU] button to exit directly.

During the calibration process, Error prompt appears on the screen when the reference liquid is incorrect or sensor can not be calibrated. (Replacement Sensor Required) The slope of glass electrode (> 0.90) is qualified.

pH Buffer Reading vs Temperature

Temp(°C)	pH 4.01	pH 6.86	pH 9.18	pH 4.00	pH 7.00	pH 10.01
0	4.01	6.98	9.47	4.01	7.12	10.32
5	4.01	6.95	9.38	4.00	7.09	10.25
10	4.00	6.92	9.32	4.00	7.06	10.18
15	4.00	6.90	9.27	4.00	7.04	10.12
20	4.00	6.88	9.22	4.00	7.02	10.06
25	4.01	6.86	9.18	4.00	7.00	10.01
30	4.01	6.85	9.14	4.01	6.99	9.97
35	4.02	6.84	9.10	4.02	6.98	9.93
40	4.03	6.84	9.07	4.03	6.97	9.89
45	4.04	6.83	9.04	4.04	6.97	9.86
50	4.06	6.83	9.01	4.06	6.97	9.83
55	4.08	6.83	8.99	4.07	6.97	9.91
60	4.10	6.84	8.96	4.09	6.98	9.97
70	4.12	6.85	8.92	4.12	6.99	9.76
80	4.16	6.86	8.89	4.16	7.00	9.74
90	4.01	6.88	8.85	4.20	7.02	9.73

ORP Calibration: Press the  [MENU] button to enter the calibration mode, select ORP standard liquid calibration, and input the known standard liquid value (Default 235mV).

Press the  [MENU] button to return to the measurement screen and press the  [CAL] button to enter the standard solution calibration mode. If there is no need to modify the value, this setting is omitted.

Press the  [CAL] button to enter the calibration mode. After entering the calibration mode, the instrument will be displayed as the upper right image, and the corresponding mV value will be displayed on the left side of the screen.

After the calibration is completed, the slope will be displayed on the right side of the screen. If the instrument has been calibrated, press the  [CAL] button to inspect the calibration state, and then press the  [ENT] button to enter the re-calibration.

Field Calibration

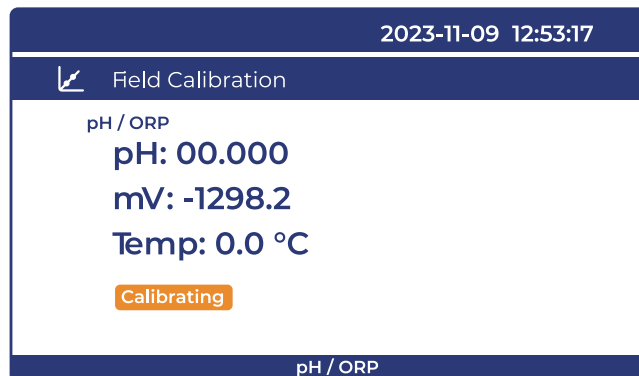

Measurement Settings (Quick Start)

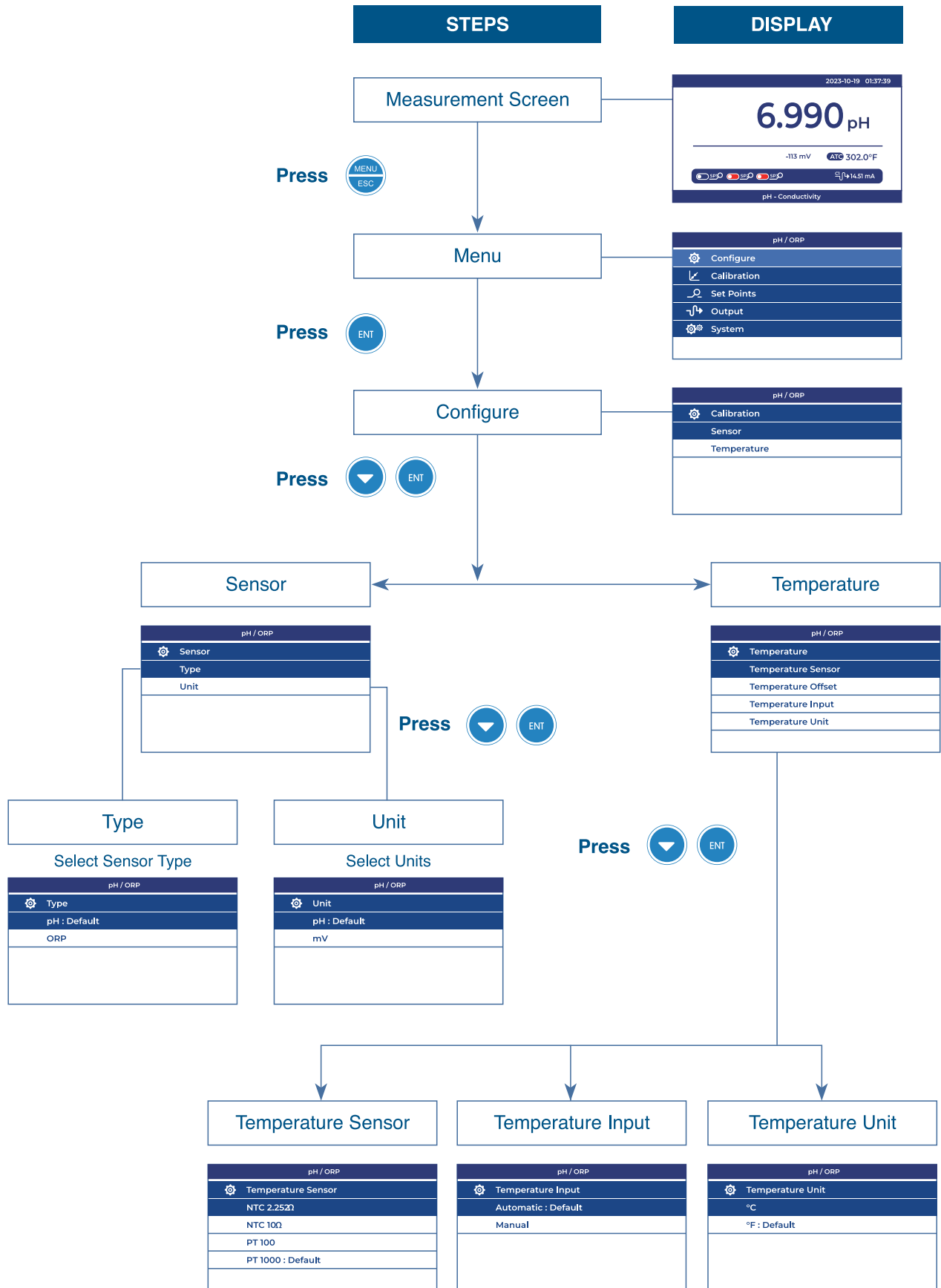

SimpliCal® Calibration (Quick Start)

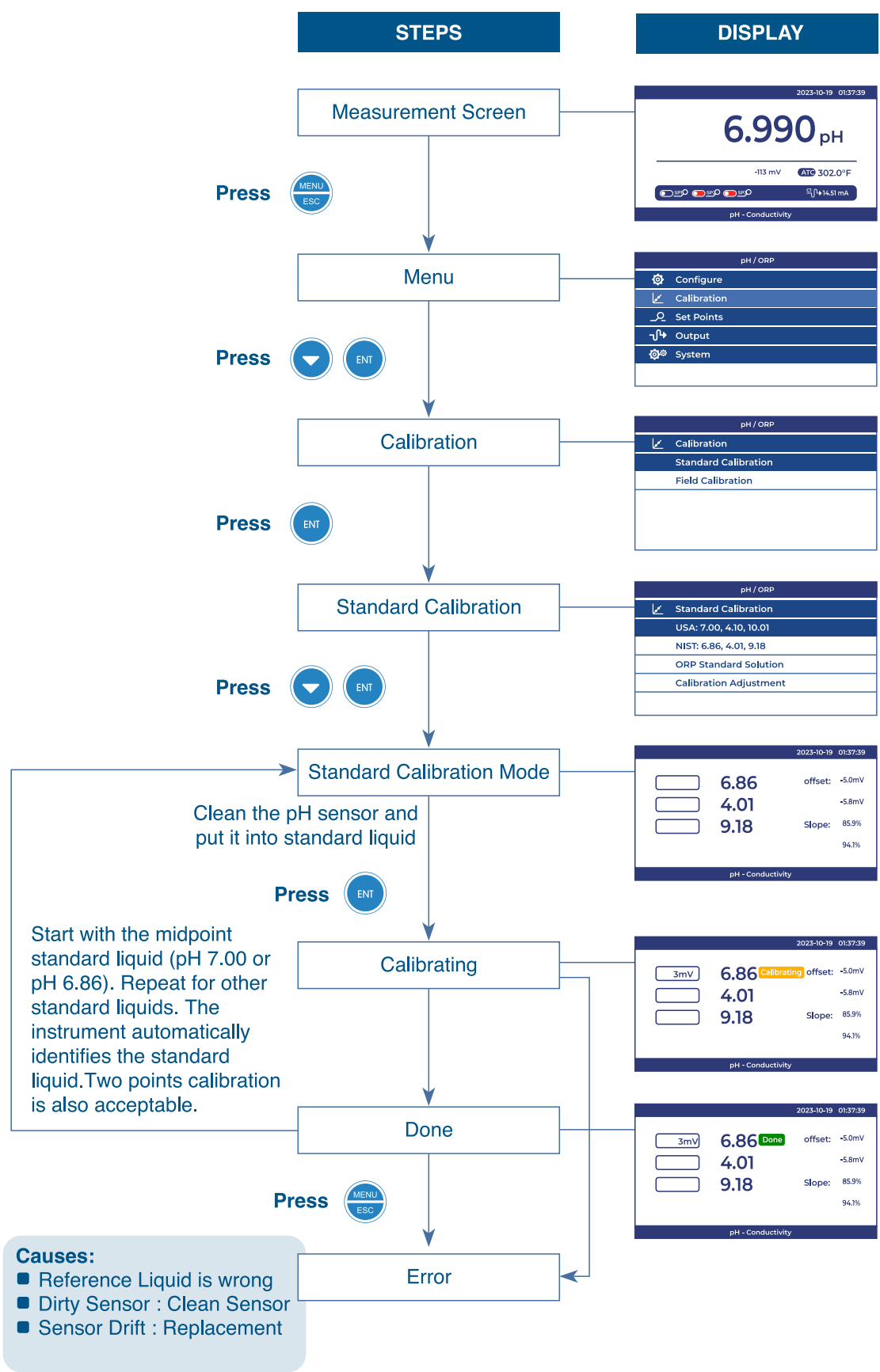

Field Calibration (Quick Start)

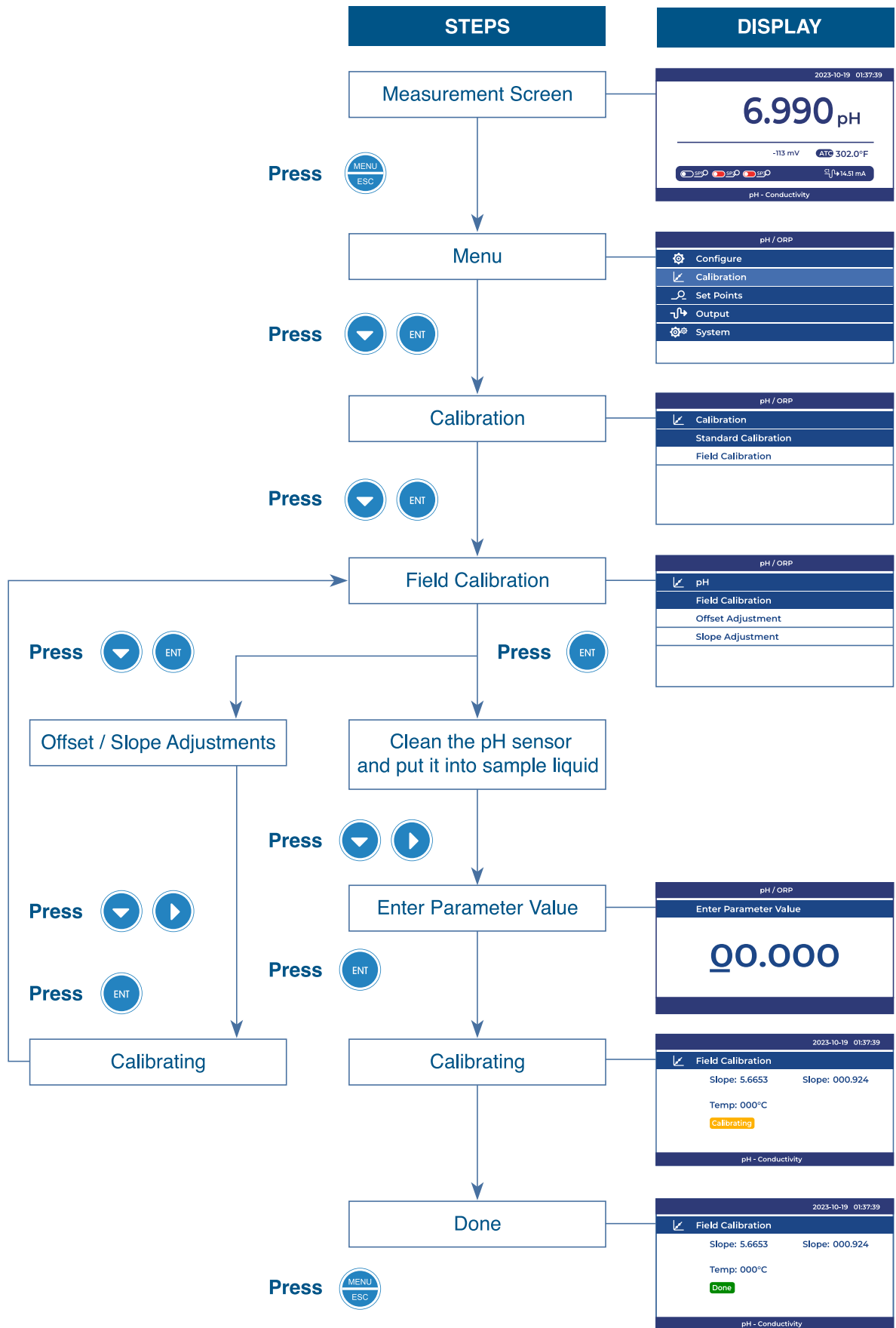

Calibration Adjustment (Quick Start)

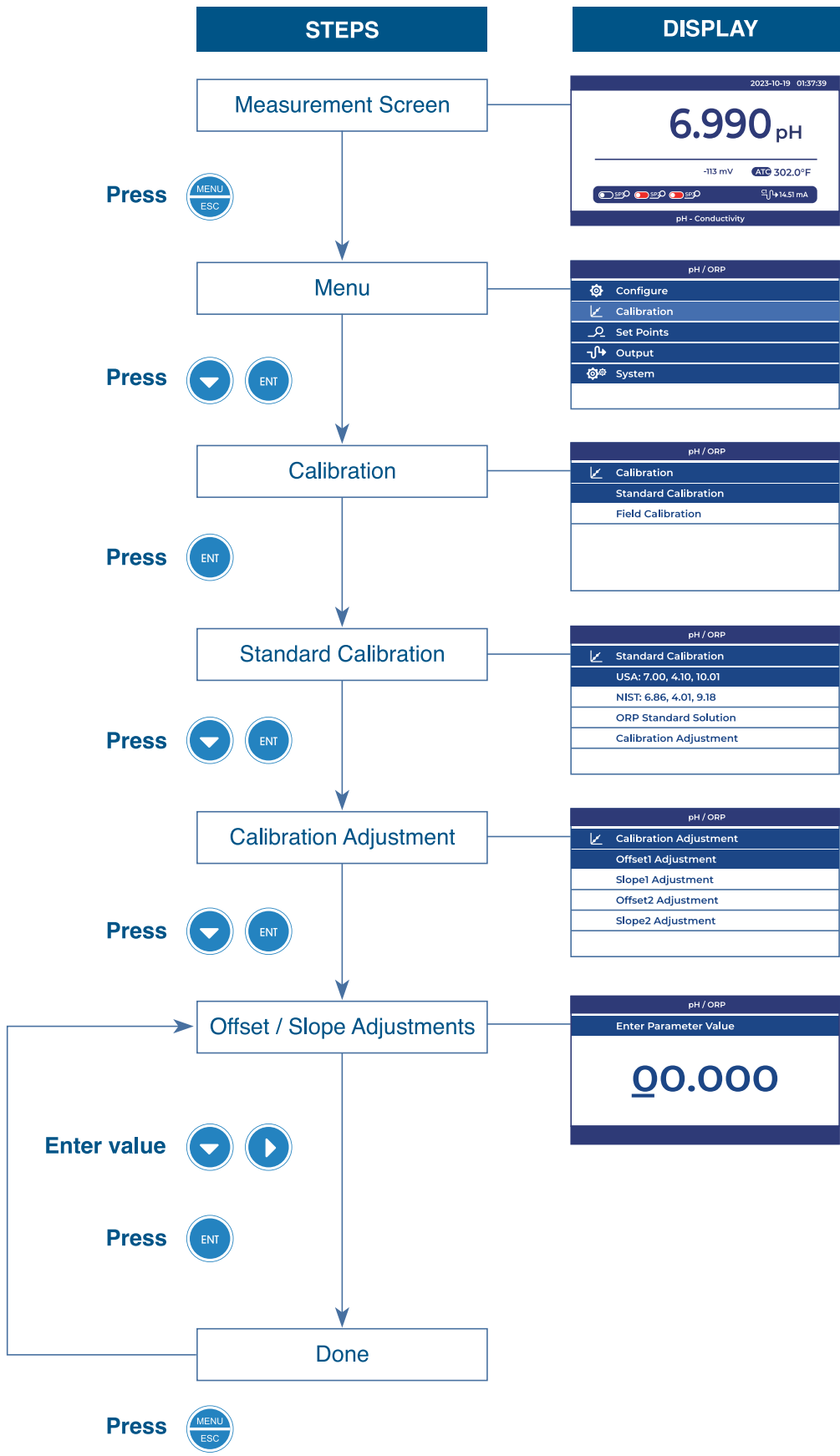

Alarm / Relay Settings (Quick Start)

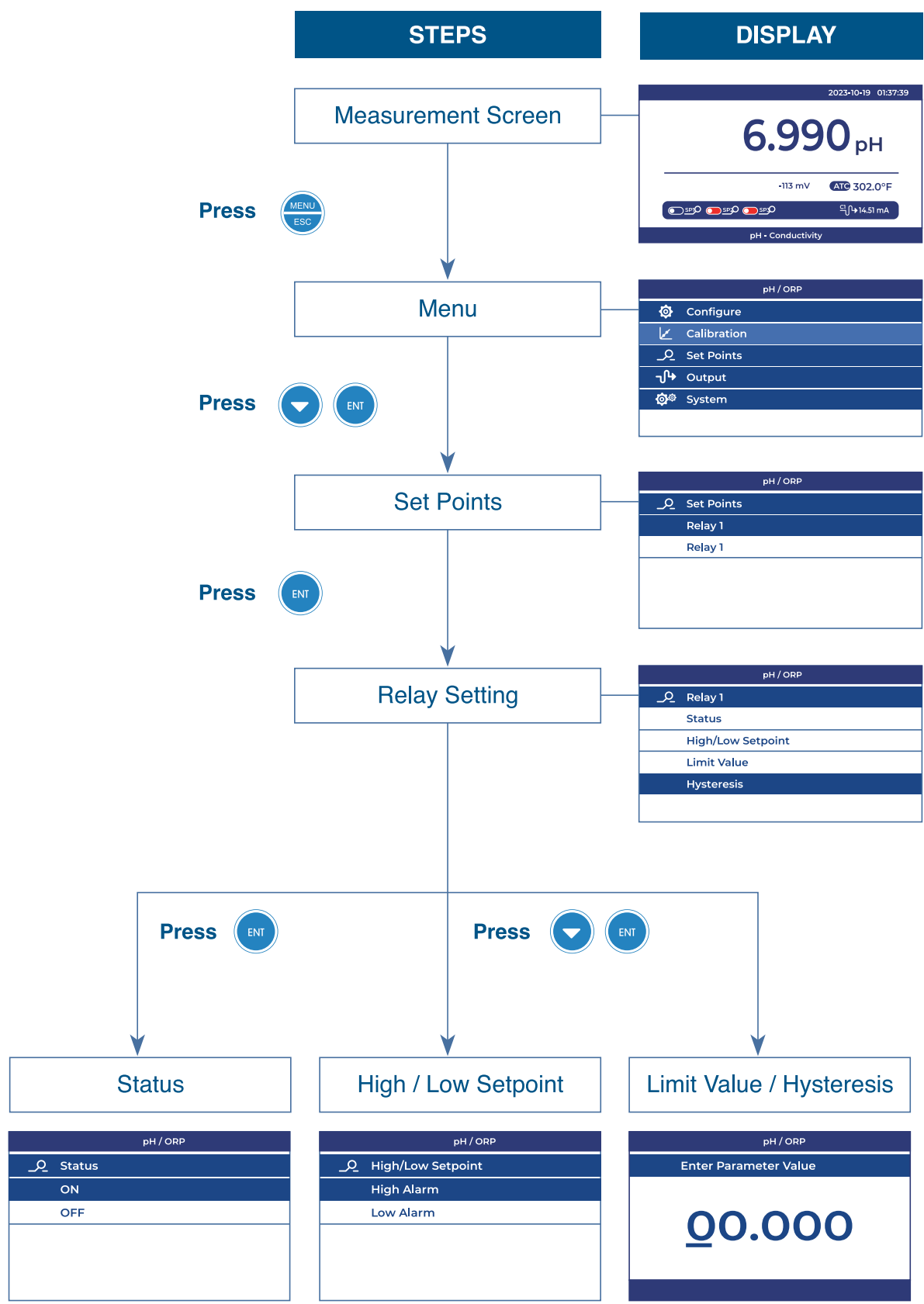

Output Settings (Quick Start)

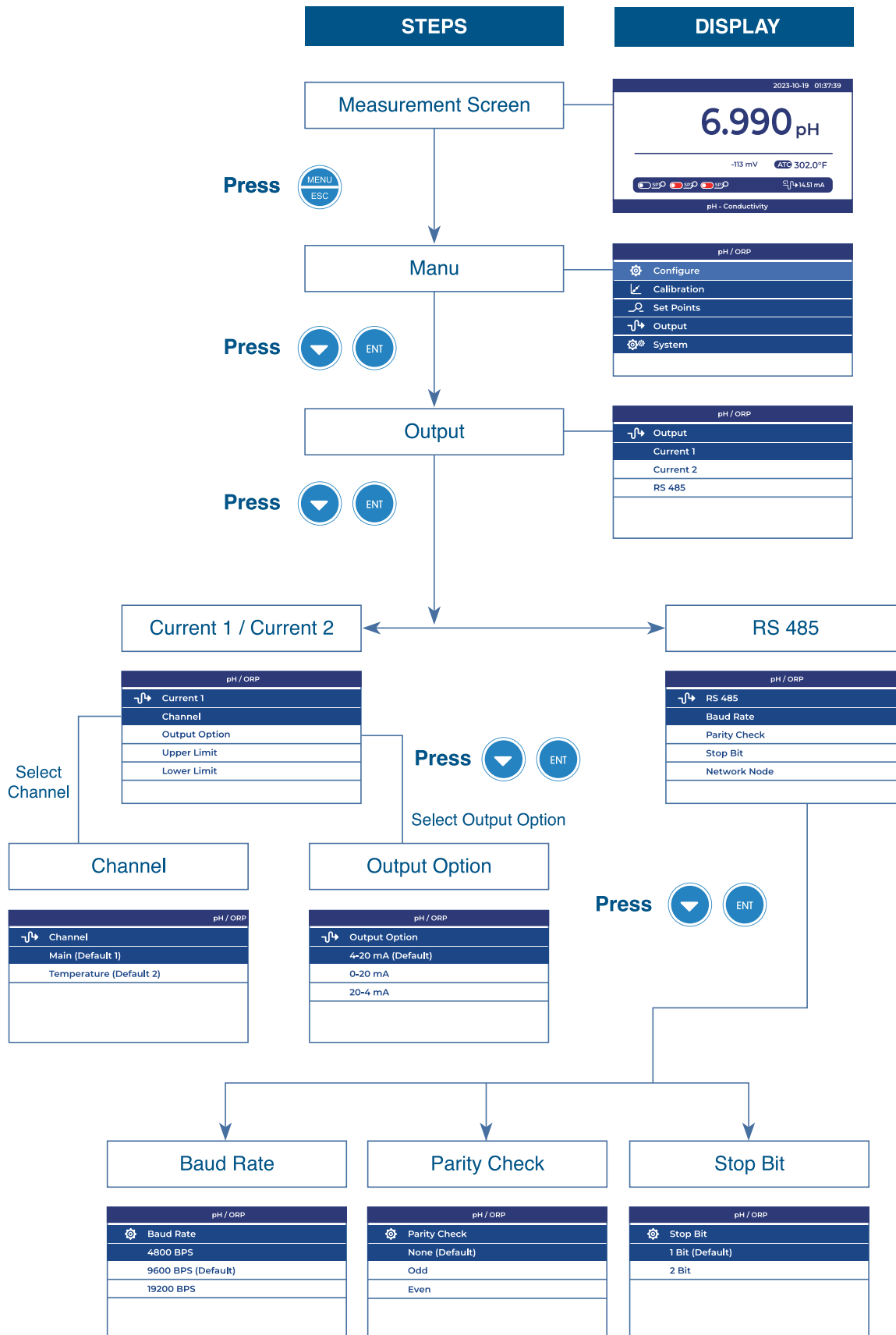

Measurement Settings (Quick Start)

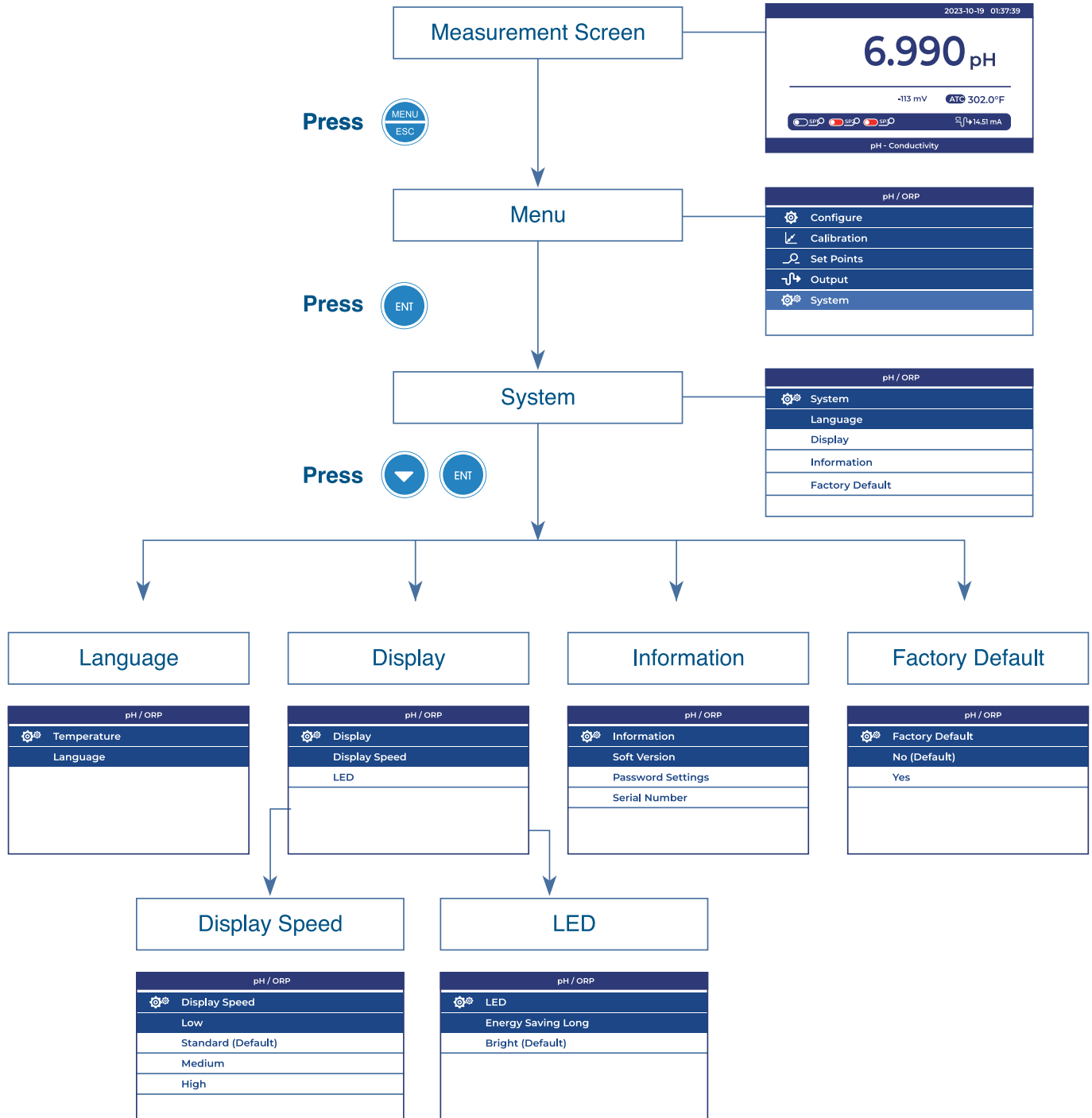

MODBUS RTU General Information

Overview

The hardware version number of this document is V2.0; the software version number is V5.9 and above. This document describes the MODBUS RTU interface in details and the target object is a software programmer.

MODBUS Command Structure

Data format description in this document;

Binary display, suffix B, for example: 10001B

- decimal display, without any prefix or suffix, for example: 256

Hexadecimal display, prefix 0x, for example: 0x2A

ASCII character or ASCII string display, for example: "YL0114010022"

Command Structure

The MODBUS application protocol defines the Simple Protocol Data Unit (PDU), which is independent of the underlying communication layer.

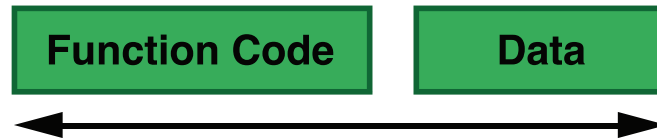

Figure 1: MODBUS Protocol Data Unit

MODBUS protocol mapping on a specific bus or network introduces additional fields of protocol data units. The client that initiates the MODBUS exchange creates the MODBUS PDU, and then adds the domain to establish the correct communication PDU.

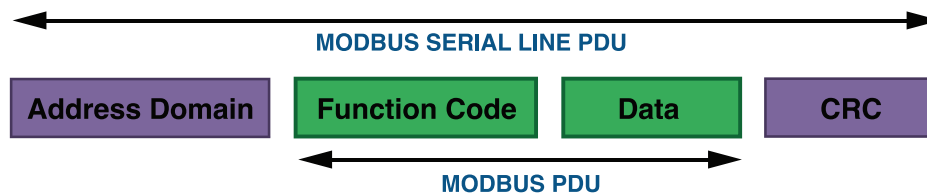

Figure2: MODBUS architecture for serial communication

On the MODBUS serial line, the address domain contains only the slave instrument address. Tips: The device address range is 1...247. Set the device address of the slave in the address field of the request frame sent by the host. When the slave instrument responds, it places its instrument address in the address area of the response frame so that the master station knows which slave is responding. Function codes indicate the type of operation performed by the server. CRC domain is the result of the "redundancy check" calculation, which is executed according to the information content.

MODBUS RTU Transmission Mode

When the instrument uses RTU (Remote Terminal Unit) mode for MODBUS serial communication, each 8-bit byte of information contains two 4-bit hexadecimal characters. The main advantages of this mode are greater character density and better data throughput than the ASCII mode with the same baud rate. Each message must be transmitted as a continuous string.

The format of each byte in RTU mode (11 bits):

Coding system: 8-bit binary

Each 8-bit byte in a message contains two 4-bit hexadecimal characters (0-9, A-F)

Bits in each byte: 1 starting bit

8 data bits, the first minimum valid bits without parity check bits

2 stop bits

Baud rate: 9600 BPS

How characters are transmitted serially:

Each character or byte is sent in this order (from left to right) the least significant bit (LSB)... Maximum

Significant Bit (MSB)



Figure 3: RTU pattern bit sequence

Check Domain Structure: Cyclic Redundancy Check (CRC16)

Structure description:

Slave Instrument	Function Code	Data	CRC	
Address	1 byte	0...252 byte	2 byte	
			CRC Low byte	CRC Low byte

Figure 4: RTU information structure

The maximum frame size of MODBUS is 256 bytes MODBUS RTU Information Frame In RTU mode, message frames are distinguished by idle intervals of at least 3.5 character times, which are called t3.5 in subsequent sections.

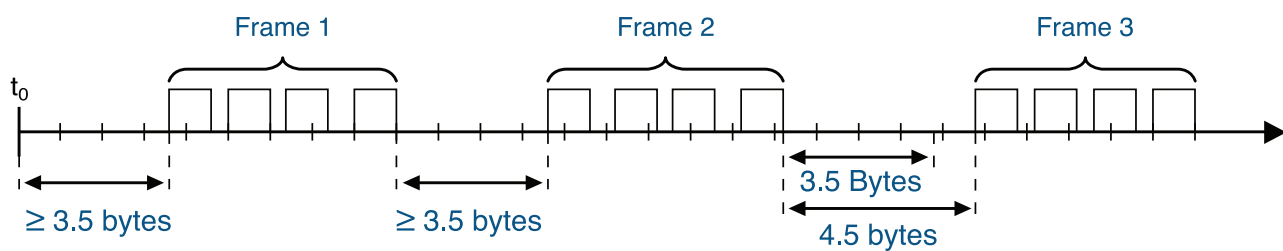

Start	Address	Function code	Date	CRC	Stop
≥3.5 bytes	8	8	Nx8	16	≥3.5 bytes

Figure 5: RTU Message Frame

The entire message frame must be sent in a continuous character stream. When the pause time interval between two characters exceeds 1.5 characters, the information frame is considered incomplete and the receiver does not receive the information frame.

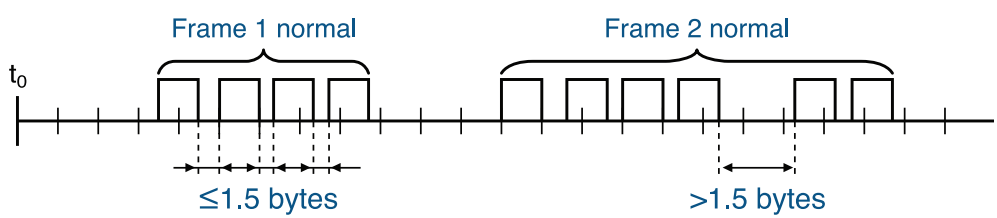

Figure 6: Frame data transmission

MODBUS RTU CRC Check

The RTU mode contains an error-detection domain based on a cyclic redundancy check (CRC) algorithm that performs on all message contents. The CRC domain checks the contents of the entire message and performs this check regardless of whether the message has a random parity check. The CRC domain contains a 16-bit value consisting of two 8-bit bytes. CRC16 check is adopted. Low bytes precede, high bytes precede.

Implementation of MODBUS RTU in Instrument

According to the official MODBUS definition, the command starts with a 3.5 character interval triggering command, and the end of the command is also represented by a 3.5 character interval. The device address and MODBUS function code have 8 bits. The data string contains $n \times 8$ bits, and the data string contains the starting address of the register and the number of read/write registers. CRC check is 16 bits.

Value	Start	Device Address	Function Code	Data	CRC		Stop
	No signal bytes during 3.5 characters	1-247	Function codes conforming to MODBUS specification	Data conforming to MODBUS specification	CRCL	CRCL	No signal bytes during 3.5 characters
Byte	3.5		1	n	1	1	3.5

Figure 7: MODBUS definition of data transmission

Instrument MODBUS RTU function code

The instrument only uses two MODBUS function codes:

0x03: Read-and-hold register

0x10: Write multiple registers

MODBUS Function Code 0x03: Read-and-hold Register

This function code is used to read the continuous block content of the holding register of the remote device. Request the PDU to specify the start register address and the number of registers. Address registers from zero. Therefore, the addressing register 1-16 is 0-15. The register data in the response information is packaged in two bytes per register. For each register, the first byte contains high bits and the second byte contains low bits.

Request:

Function Code	1 byte	0x03
Start Address	2 bytes	0x0000...0xffff
Read Register Number	2 bytes	1...125

Figure 8: Read-and-hold register request frame

Response:

Function Code	1 byte	0x03
Start Address	2 bytes	0x0000...0xffff
Read Register Number	2 bytes	1...125

N = Register number

Figure 9: Read-and-hold register response frame

The following illustrates the request frame and response frame with the read and hold register 108-110 as an example. (The contents of register 108 are read-only, with two-byte values of 0X022B, and the contents of register 109-110 are 0X0000 and 0X0064)

Request Frame		Response Frame	
Number Systems	(Hexadecimal)	Function code	(Hexadecimal)
Function code	0x03	Register Value (High Bytes) (108)	0x03
Start address (high byte)	0x00	Register Value (Low Bytes)(108)	0x06
Start address (low byte)	0x6B	Register Value (High Bytes) (109)	0x02
Number of Read Registers (High Bytes)	0x00	Register Value (Low Bytes) (109)	0x2B
Number of Read Registers (Low Bytes)	0x00	Register Value (High Bytes)(110)	0x00
		Register Value (High Bytes)(110)	0x00
		Register Value (Low Bytes) (110)	0x00
		Function code	0x64

Figure 10: Examples of read and hold register request and response frames

MODBUS function code 0x10: write multiple registers

This function code is used to write continuous registers to remote devices (1... 123 registers) block that specifies the value of the registers written in the request data frame. Data is packaged in two bytes per register. Response frame return function code, start address and number of registers written.

Request:

Function Code	1 byte	0x03
Start Address	2 bytes	0x0000...0xffff
Number of Input Registers	2 bytes	1..125
Number of Bytes	1 byte	Nx2
Register Values	Nx2 bytes	Value

N = Register number

Figure 11: Write multiple register request frames

Response:

Function Code	1 byte	0x03
Start Address	2 bytes	0x0000...0xffff
Number of Input Registers	2 bytes	1..125
Number of Bytes	1 byte	Nx2
Register Values	Nx2 bytes	Value

N = Register number

Figure 12: Write multiple register response frames

The request frame and response frame are illustrated below in two registers that write the values 0x000A and 0x0102 to the start address of 2.

Request Frame	(hexidecimal)	Response Frame	(hexidecimal)
Number Systems	0x10	Function code	0x10
Function code	0x00	Register Value (High Bytes) (108)	0x00
Start address (high byte)	0x01	Register Value (Low Bytes)(108)	0x01
Start address (low byte)	0x00	Register Value (High Bytes) (109)	0x00
Number of Read Registers (High Bytes)	0x02	Register Value (Low Bytes) (109)	0x02
Number of Read Registers (Low Bytes)	0x04	Register Value (High Bytes)(110)	0x00
Number of bytes	0x00		
Register value (high byte)	0x0A		
Register value (low byte)	0x01		
Register value (high byte)	0x02		
Register value (low byte)			

Figure 13: Examples of writing multiple register request and response frames

Data Format

Overview

Floating Point

Definition : Floating point, conforming to IEEE 754 (single precision)

Description	Symbol	Index	Mantissa	SUM
Bit	3	30...23	22...0	22...0
Index Deviation	127			

Figure 14: floating point single-precision definition (4 bytes, 2 MODBUS registers)

Example: Compile decimal 17.625 to binary

Step 1: Converting 17.625 in decimal form to a floating-point number in binary form, first finding the binary representation of the integer part 17
 Decimal = $16 + 1 = 1 \times 2^4 + 0 \times 2^3 + 0 \times 2^2 + 0 \times 2^1 + 1 \times 2^0$

The binary representation of integer part 17 is 10001B then the binary representation of decimal part is obtained $0.625 = 0.5 + 0.125 = 1 \times 2^{-1} + 0 \times 2^{-2} + 1 \times 2^{-3}$

The binary representation of decimal part 0.625 is 0.101B.

So the binary floating point number of 17.625 in decimal form is 10001.101B

Step 2: Shift to find the exponent.

Move 10001.101B to the left until there is only one decimal point, resulting in 1.0001101B, and $10001.101B = 1.0001101B \times 2^4$. So the exponential part is 4, plus 127, it becomes 131, and its binary representation is 10000011B.

Step 3: Calculate the tail number

After removing 1 before the decimal point of 1.0001101B, the final number is 0001101B (because before the decimal point must be 1, so IEEE stipulates that only the decimal point behind can be recorded). For the important explanation of 23-bit mantissa, the first (i.e. hidden bit) is not compiled.

Hidden bits are bits on the left side of the separator, which are usually set to 1 and suppressed.

Step 4: Symbol bit definition

The sign bit of positive number is 0, and the sign bit of negative number is 1, so the sign bit of 17.625 is 0.

Step 5: Convert to floating point number

1 bit symbol + 8 bit index + 23-bit mantissa 0 10000011 00011010000000000000000B
 (the hexadecimal system is shown as 0 x418d0000)

Read Instruction Mode

The communication protocol adopts MODBUS (RTU) protocol. The content and address of the communication can be changed according to the needs of customers. The default configuration is network address 01, baud rate 9600, even check, one stop bit, users can set their own changes; Function code 0x04: This function enables the host to obtain real-time measurements from slaves, which are specified as single-precision floating-point type (i.e. occupying two consecutive register addresses), and to mark the corresponding parameters with different register addresses.

Communication address is as follows:

- 0000-0001: Temperature value
- 0002-0003: Main Measured Value
- 0004-0005: Temperature and Voltage Value
- 0006-0007: Main Voltage Value

Communication examples:

Examples of function code 04 instructions:

Communication address = 1, temperature = 20.0, ion value = 10.0, temperature voltage = 100.0, ion voltage = 200.0

Host Send: 01 04 00 00 08 F1 CC

Slave Response: 01 04 10 00 00 41 A0 00 00 41 20 00 00 42 C8 00 00 43 48 81 E8

Note:

- [01] Represents the instrument communication address;
- [04] Represents function code 04;
- [10] represents 10H (16) byte data;
- [00 00 00 41 A0] = 20.0; / temperature value
- [00 00 41 20] = 10.0; // Main Measured Value
- [00 00 42 C8] = 100.0; // Temperature and Voltage Value
- [00 00 43 48] = 200.0; // Main measured voltage value
- [81 E8] represents CRC16 check code;

Daily Maintenance

Certain ProCon sensors Instruments require routine maintenance, ex. pH calibration.

Simple Check Method: set the parameter zero offset as 0.0mV and the slope as 1.00, then shortcircuit the terminal "Input" and "Ref", the instrument should be displayed in 7.000 or within the error range; If the display is not correct, please contact the manufacturer for maintenance.

Please pay attention to the following points for the maintenance of sensors.

1. When adopting the circulation structure, the velocity of inlet water sample should be kept as constant as possible.
2. When leaving the factory, there is a protective cap on the head of the electrode, which contains electrode soaking solution to maintain the moisture of the sensitive membrane. The protective cap should be taken off before use and screwed on when not in use.
3. The new electrode can be immersed in 3.3m KCl concentration immersion solution for one day and night to ensure the accuracy of calibration.
4. Calibration before installation is recommended.
5. When the site is out of water for a long time and not in use, the electrode should be screwed on the protective cap in time, and 3.3m concentration of immersion solution should be put into the protective cap.
6. Dirt on the glass ball on the top of the electrode can be cleaned with 0.1N hydrochloric acid and then invaded into the 3.3m KCl solution for activation.
7. Do not touch it by hand.
8. To ensure long-term accurate measurement, the electrode should be cleaned, maintained and calibrated regularly.
9. (9) Sensor should be replaced when calibration is no longer effective. **When the electrode is not in use, the electrode should be immersed in the solution. The preparation of the soaking solution: take a package of pH4 buffer, dissolve in 250ml pure water, then add 56g of analytical pure KCl, heat and stir it until it is completely dissolved.(note: the electrode is easy to fail when stored in the dry discharge state)**

Troubleshooting

1. LCD display is not bright

Possible Causes: Instrument or LCD Screen power supply failure.

Solutions: Check whether the power supply is connected or not, and check whether the power supply wire of the sensor is connected in the wrong direction.

2. No current output

Possible Causes: It could be a fault in the current module or a wiring fault.

Solutions: Please check that the current output wiring is correct. Please refer to the wiring terminal diagram in the instructions.

3. The output current of the transmitter does not match the display current.

Possible Causes: Current output may not be correctly calibrated.

Solutions: Please re-calibrate the 20mA output.

4. There is a on the screen.

Possible causes: The transmitter does not communicate properly with the sensor. Solutions: Check whether the signal line of the sensor is correct. Please refer to the wiring diagram in the instruction.

5. Measurements display results fluctuate greatly.

Possible causes: Sensor wiring error or low display rate setting.

Solutions: Check wiring or increase display rate appropriately.

Warranty

Icon Process Controls warrants this product to be free from significant deviations in material and workmanship for a period of one year from the date of purchase. If repair is necessary and has not been the result of abuse or misuse within the warranty period, please return to **Icon Process Controls** and amendment will be made without any charge. We Instruments Customer Service Center will determine if product problem is due to deviations or customer abuse. Out of warranty products will be repaired on a charge basis.

Authorization must be obtained from **Icon Process Controls** Customer Service Center to issue a RIR number before returning items for any reason. When applying for authorization, please include date requiring the reason of return. Instruments must be carefully packed to prevent damage in shipment and insured against possible damage or loss. **Icon Process Controls** will not be responsible for any damage resulting from careless or insufficient packing.

Warning: Damage as a result of inadequate packaging is the User / distributor's responsibility. Please follow the guidelines below before transporting.

Use the original packaging material if possible, when transporting back the unit for repair. Otherwise wrap it with bubble pack and use a corrugated box for better protection. Include a brief description of any faults suspected for the convenience of Customer Service Center, if possible. If there are any questions, feel free to contact our Customer Service Center or distributors.



by



John M. Ellsworth Co., Inc.

P.O. Box 240072
8700 West Bradley Road
Milwaukee, WI 53224

800-333-3331 **PHONE**

info@jmesales.com **E-MAIL**
www.JMEsales.com **WEB**

Need a great sensor?

Pair your D400 Series controller with the industry's most innovative and reliable sensing technology



A John M. Ellsworth Company

John M. Ellsworth Co., Inc.

P.O. Box 240072
8700 West Bradley Road
Milwaukee, WI 53224

800-333-3331 **PHONE**

info@jmesales.com **E-MAIL**
www.JMESales.com **WEB**