

# Fluid Defender™

3A9335A

EN

***For monitoring lubrication fluid tank levels in above ground, stationary tanks and regulating air-powered equipment connected to the tank using air control solenoid valves. Not for use with tanks containing gasoline or any other Class I NFPA 30 flammable fluids. Not for use with tanks without required overfill containment protection, not a replacement for overfill containment protection. For professional use only.***

**Not approved for use in explosive atmospheres or hazardous (classified) locations.**

## Models

See page 3 for model information, including approvals.



### Important Safety Instructions

Read all warnings and instructions in this manual before using the equipment. Save these instructions.

## Related Manuals

| Manual in English | Description  |
|-------------------|--|
| 130641            | Pulse® Fluid Management, Register Your Devices quick guide |
| 3A7279            | Fluid Defender Level Sensor                                |
| 3A7280            | Air Control Solenoid Valve for Fluid Defender              |



ti42429a

Contains Model XBee or S2C Radio, IC:1846A-XBEE3 or 1846A-S2CTH (Models 25V471 and 25V580).

Contains FCC ID MCQ-XBEE3 or MCQ-S2CTH (Models 25V471 and 25V580). The enclosed device complies with Part 15 of the FCC Rules.



Operation is subject to the following two conditions:

- This device may not cause harmful interference.
- This device must accept any interference received, including interference that may cause undesired operation.

# Contents





|   |           |  |           |
|---|-----------|--|-----------|
| <b>Related Manuals</b> .....                                    | <b>1</b>  | <b>Recycling and Disposal</b> .....    | <b>24</b> |
| <b>Models</b> .....   | <b>3</b>  | End of Product Life .....              | 24        |
| <b>Warnings</b> .....   | <b>4</b>  | <b>Troubleshooting</b> .....           | <b>25</b> |
| <b>Typical Installation</b> .....                               | <b>6</b>  | <b>Parts</b> .....                     | <b>29</b> |
| Waste Oil High Level Shut Off .....                             | 6         | <b>Accessories</b> .....               | <b>30</b> |
| Fresh Oil Low Level .....                                       | 7         | Air Control Solenoid Valves .....      | 30        |
| Remote Bulk Fill Stop .....                                     | 8         | Bracket Light Kit (Optional) .....     | 30        |
| <b>Component Identification</b> .....                           | <b>9</b>  | Level Sensors (Required) .....         | 30        |
| Fluid Defender Exterior .....                                   | 9         | Remote Light (Optional) .....          | 30        |
| Fluid Defender Interior .....                                   | 10        | <b>Dimensions</b> .....                | <b>31</b> |
| <b>I/O Channel Dip Switch Settings</b> .....                    | <b>10</b> | Mounting Hole Layout .....             | 31        |
| <b>Wire Key for M12 External Connector</b> .....                | <b>10</b> | <b>Technical Specifications</b> .....  | <b>32</b> |
| <b>Overview</b> .....   | <b>11</b> | <b>Accessory Requirements</b> .....    | <b>33</b> |
| Definitions .....   | 11        | <b>California Proposition 65</b> ..... | <b>33</b> |
| Air Control Solenoid Valves .....                               | 11        | <b>Maintenance Log</b> .....           | <b>35</b> |
| Fluid Level Sensors .....                                       | 11        | <b>Graco Standard Warranty</b> .....   | <b>37</b> |
| High Level Sensors .....  | 12        |  |           |
| Low Level Sensors .....   | 12        |  |           |
| <b>Installation</b> .....                                       | <b>13</b> |  |           |
| Pressure Relief Procedure .....                                 | 13        |  |           |
| Fluid Defender .....  | 13        |  |           |
| Installation of Level Sensors .....                             | 14        |  |           |
| Installation of Air Control Solenoid Valves .....               | 14        |  |           |
| Installation of Remote Light (Optional) .....                   | 14        |  |           |
| Configuration of Fluid Defender .....                           | 14        |  |           |
| Register the Fluid Defender (Models 25V471<br>and 25V480) ..... | 15        |  |           |
| <b>Operation</b> .....  | <b>16</b> |  |           |
| Test System .....   | 16        |  |           |
| High Level Sensors .....  | 17        |  |           |
| Low Level Sensors .....   | 17        |  |           |
| Air Control Solenoid Valve Manual Override .....                | 18        |  |           |
| Activate Fluid Defender .....                                   | 18        |  |           |
| Alarms .....  | 19        |  |           |
| Update PULSE Firmware (Models 25V471<br>and 25V580) .....       | 20        |  |           |
| <b>Maintenance</b> .....  | <b>21</b> |  |           |
| Periodic Testing .....  | 21        |  |           |
| Weekly (and before every remote bulk fill) .....                | 21        |  |           |
| Monthly .....   | 21        |  |           |
| Replace Rotating Beacon Alarm .....                             | 21        |  |           |
| Replace Fuse .....  | 23        |  |           |

# Models

| Part No. | Pulse Compatible | Operating Voltage | Plug             | Approvals  |
|----------|------------------|-------------------|------------------|--|
| 25V470   | No               | 120 VAC - 60 Hz   | Nema 5 - 15 plug | <br><b>Intertek</b><br>3132066<br>Conforms to UL Standard<br>61010-1 and 61010-2 201<br>Certified to CAN/CSA<br>Standard C22.2 No. 61010-1<br>and 61010-2 201 |
| 25V471   | Yes              | 120 VAC - 60 Hz   | Nema 5 - 15 plug |  |
| 25V579   | No               | 230 VAC - 50 Hz   | AS/NZS 3112 plug |   |
| 25V580   | Yes              | 230 VAC - 50 Hz   | AS/NZS 3112 plug |  |

# Warnings

The following warnings are for the setup, use, grounding, maintenance, and repair of this equipment. The exclamation point symbol alerts you to a general warning and the hazard symbols refer to procedure-specific risks. When these symbols appear in the body of this manual or on warning labels, refer back to these Warnings. Product-specific hazard symbols and warnings not covered in this section may appear throughout the body of this manual where applicable.

|  <h2 style="margin: 0;">WARNING</h2>   |   |
|---|---|
| <br>    | <p><b>ELECTRIC SHOCK HAZARD</b></p> <p>This equipment must be grounded. Improper grounding, setup, or usage of the system can cause electric shock.</p> <ul style="list-style-type: none"> <li>• Turn off and disconnect power cord before servicing equipment.</li> <li>• Connect only to grounded electrical outlets.</li> <li>• Use only 3-wire extension cords.</li> <li>• Ensure ground prongs are intact on power and extension cords.</li> <li>• All electrical wiring must be done by a qualified electrician and comply with all local codes and regulations.</li> <li>• Wait 1 minute after disconnecting power cord before servicing.</li> </ul>   |
| <br> | <p><b>FIRE AND EXPLOSION HAZARD</b></p> <p>When flammable fluids are present in the work area, such as gasoline and windshield wiper fluid, be aware that flammable fumes can ignite or explode. To help prevent fire and explosion:</p> <ul style="list-style-type: none"> <li>• Use equipment only in well-ventilated area.</li> <li>• Eliminate all ignition sources, such as cigarettes and portable electric lamps.</li> <li>• Ground all equipment in the work area.</li> <li>• Keep work area free of debris, including rags and spilled or open containers of solvent and gasoline.</li> <li>• Do not plug or unplug power cords or turn lights on or off when flammable fumes are present.</li> <li>• Use only grounded hoses.</li> <li>• <b>Stop operation immediately</b> if static sparking occurs or you feel a shock. Do not use equipment until you identify and correct the problem.</li> <li>• Keep a working fire extinguisher in the work area.</li> </ul> |

# WARNING



## EQUIPMENT MISUSE HAZARD

Misuse can cause death or serious injury.



- Do not operate the unit when fatigued or under the influence of drugs or alcohol.
- Do not exceed the maximum working pressure or temperature rating of the lowest rated system component. See **Technical Specifications** in all equipment manuals.
- Use fluids and solvents that are compatible with equipment wetted parts. See **Technical Specifications** in all equipment manuals. Read fluid and solvent manufacturer's warnings. For complete information about your material, request Safety Data Sheets (SDSs) from distributor or retailer.
- Turn off all equipment and follow the **Pressure Relief Procedure** when equipment is not in use.
- Check equipment daily. Repair or replace worn or damaged parts immediately with genuine manufacturer's replacement parts only.
- Do not alter or modify equipment. Alterations or modifications may void agency approvals and create safety hazards.
- Make sure all equipment is rated and approved for the environment in which you are using it.
- Use equipment only for its intended purpose. Call your distributor for information.
- Route hoses and cables away from traffic areas, sharp edges, moving parts, and hot surfaces.
- Do not kink or over bend hoses or use hoses to pull equipment.
- Keep children and animals away from work area.
- Comply with all applicable safety regulations.



## PERSONAL PROTECTIVE EQUIPMENT

Wear appropriate protective equipment when in the work area to help prevent serious injury, including eye injury, hearing loss, inhalation of toxic fumes, and burns. Protective equipment includes but is not limited to:

- Protective eyewear, and hearing protection.
- Respirators, protective clothing, and gloves as recommended by the fluid and solvent manufacturer.

# Typical Installation

There are multiple system configurations possible. The typical installations shown in FIG. 1 - FIG. 3 are the three targeted applications for the Fluid Defender. Each typical installation shown is configurable as a single separate channel. Follow all local codes and regulations for tank installations. Consult your local Graco representative or distributor for system design assistance.

## Waste Oil High Level Shut Off

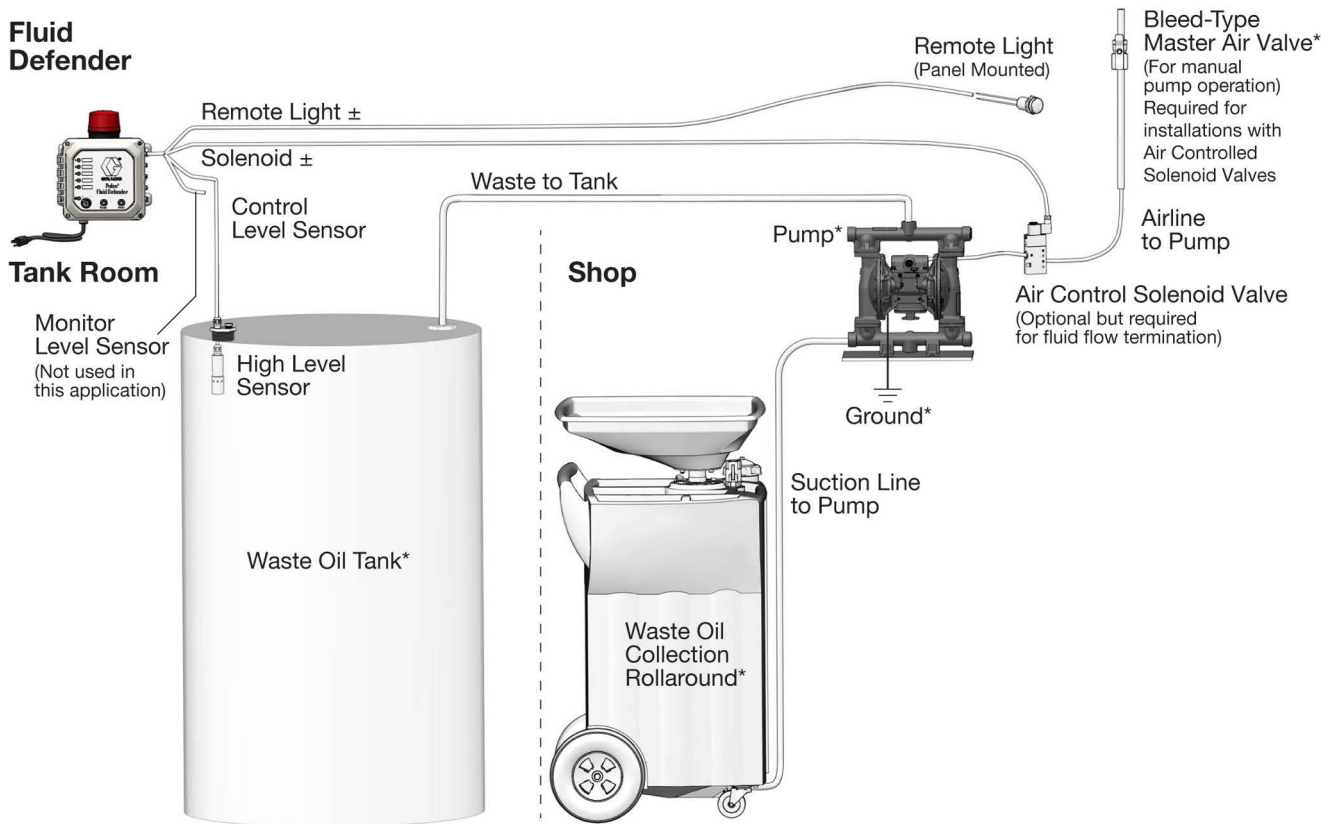

\*User supplied

ti42436a

FIG. 1

# Fresh Oil Low Level

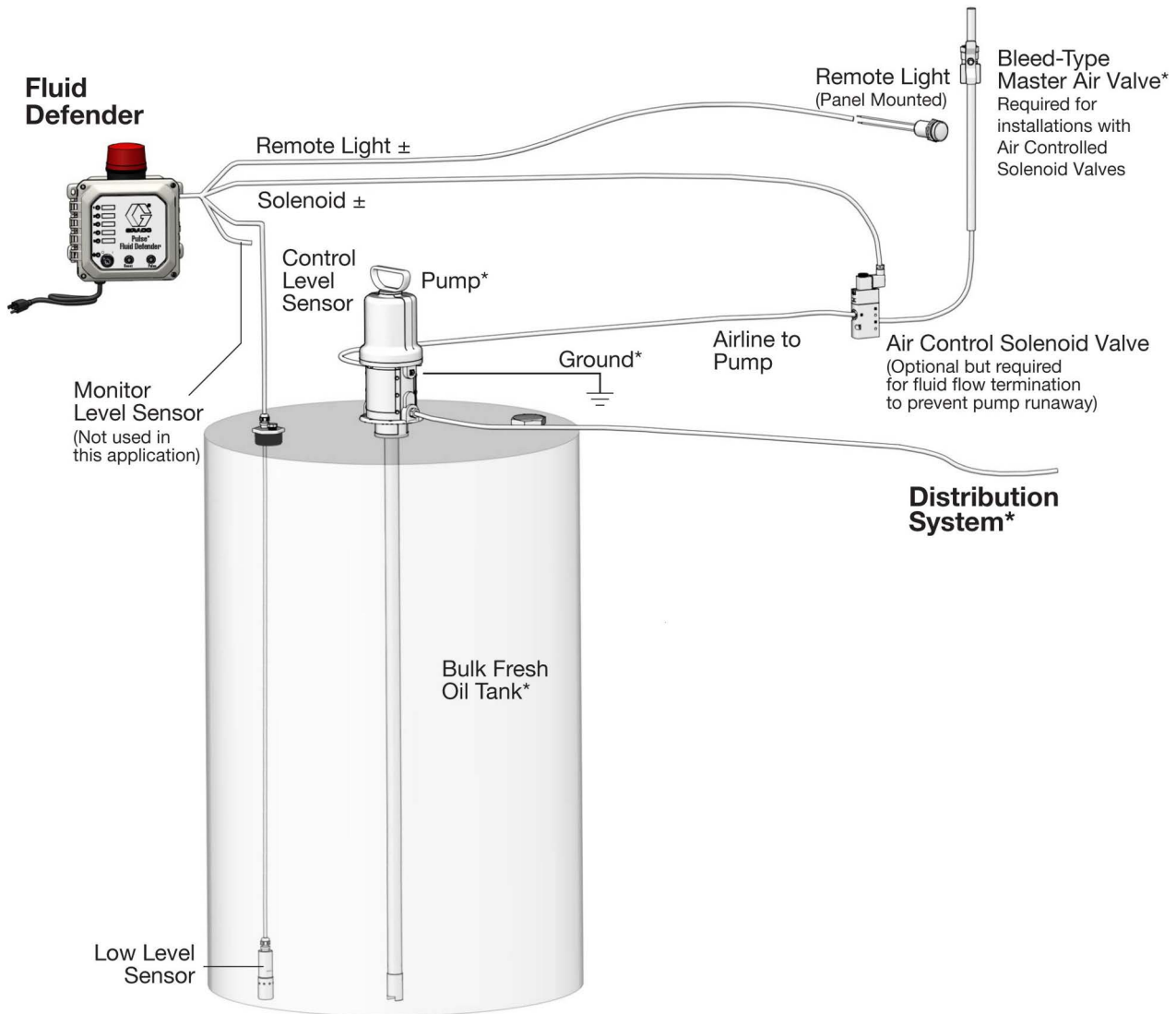

\*User supplied

ti42437a

**FIG. 2**

# Remote Bulk Fill Stop

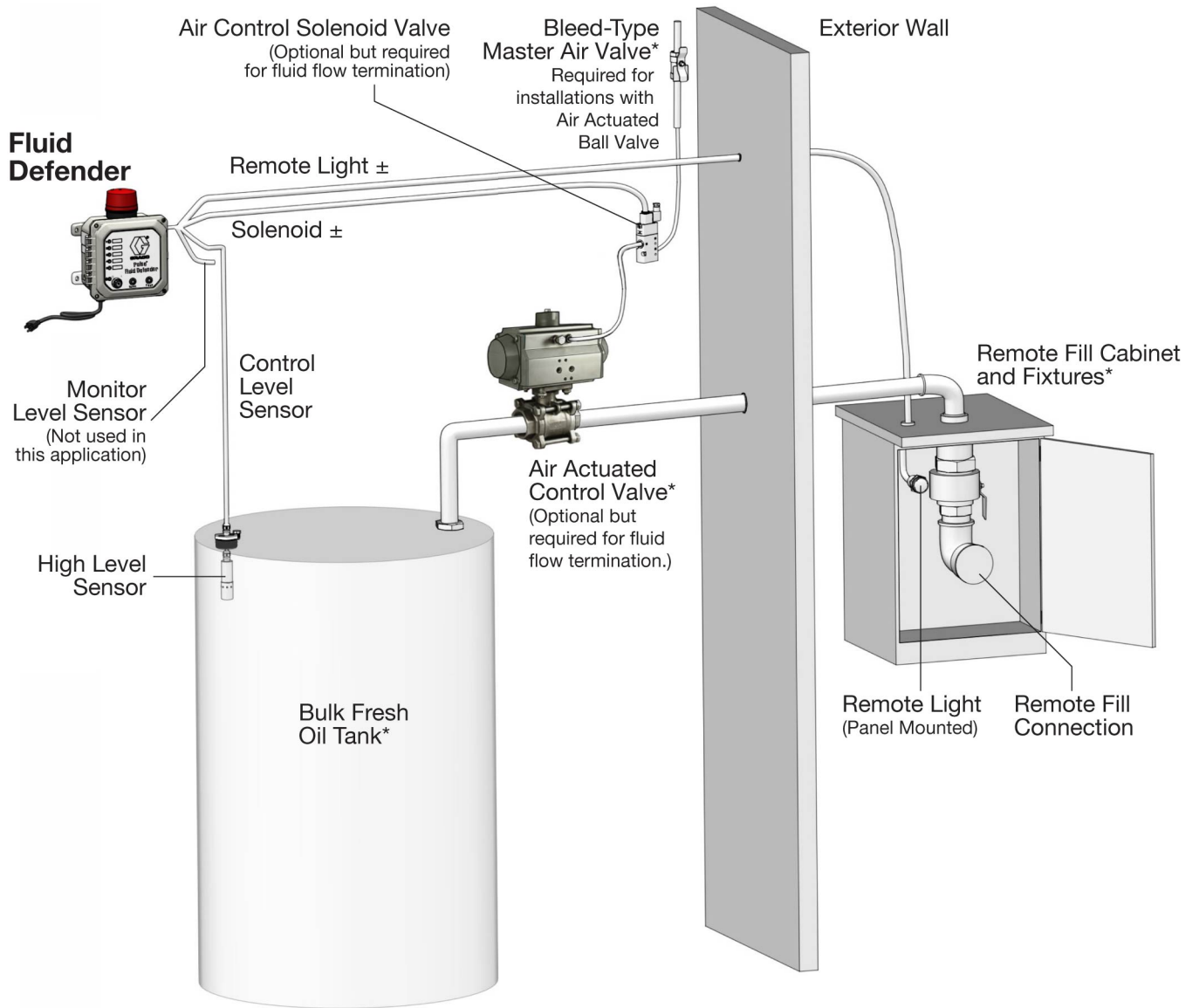

\*User supplied

ti42438a

**FIG. 3**



# Component Identification

## Fluid Defender Exterior

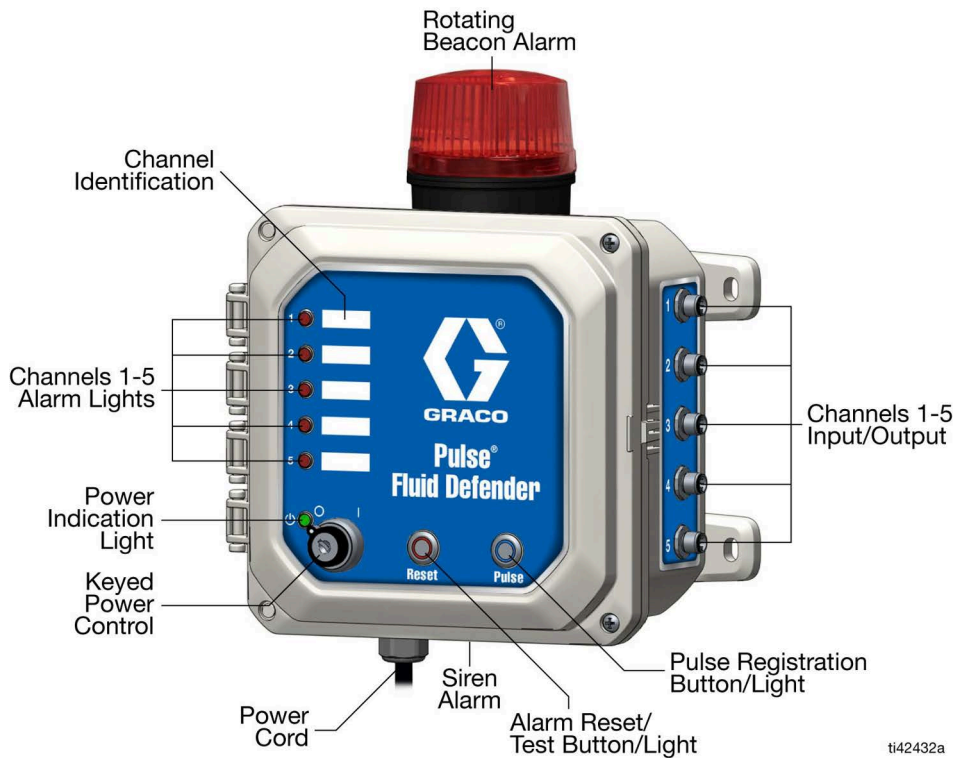

ti42432a

**FIG. 4**

|                                 |   |
|---------------------------------|---|
| Rotating Beacon Alarm           | The rotating beacon activates on any alarm condition for any channel.   |
| Input/Output (I/O)              | Connects M12 external connectors to the Fluid Defender. Accessory wires are connected to the M12 external connectors.   |
| PULSE Registration Button/Light | Used for PULSE® Discovery and firmware updates.<br>PULSE Discovery: Press the button once during setup to register with the PULSE Fluid Management System.<br>The PULSE button light is on during communication with the PULSE Hub, and the PULSE button light is off when communication with the PULSE Hub is lost.<br>Firmware Update: Press and hold the button for ten seconds (reference <b>Update PULSE Firmware (Models 25V471 and 25V580)</b> , page 20).   |
| Alarm Reset/Test Button/Light   | Resets and tests the alarms.<br>Reset: Press the button once to deactivate alarm.<br>Alarm Test: Press and hold the button for five seconds. Press the button again to reset the alarm.   |
| Siren Alarm                     | The siren activates on an alarm condition for any channel.  |
| Power Cord                      | Connects Fluid Defender to the power supply   |
| Keyed Power Control             | Control key to turn the power on and off to the Fluid Defender.   |
| Power Indication Light          | The solid green light is on while the system is powered.  |
| Alarm Lights                    | Indicates alarm status and identifies the channel in alarm.<br>The Fluid Defender alarm lights are channel specific. Channels 1 to 5 are arranged from top to bottom on the Fluid Defender front cover. They are channel specific to the five M12 cable assemblies connected to the side of the Fluid Defender.<br>The channel alarm light and optional remote light remain on until the alarm condition is corrected, either by filling or emptying the tank in alarm status. A fluid level change is required to reset the level sensors. |
| Channel Identification          | Labels for indicating channels.   |

# Fluid Defender Interior

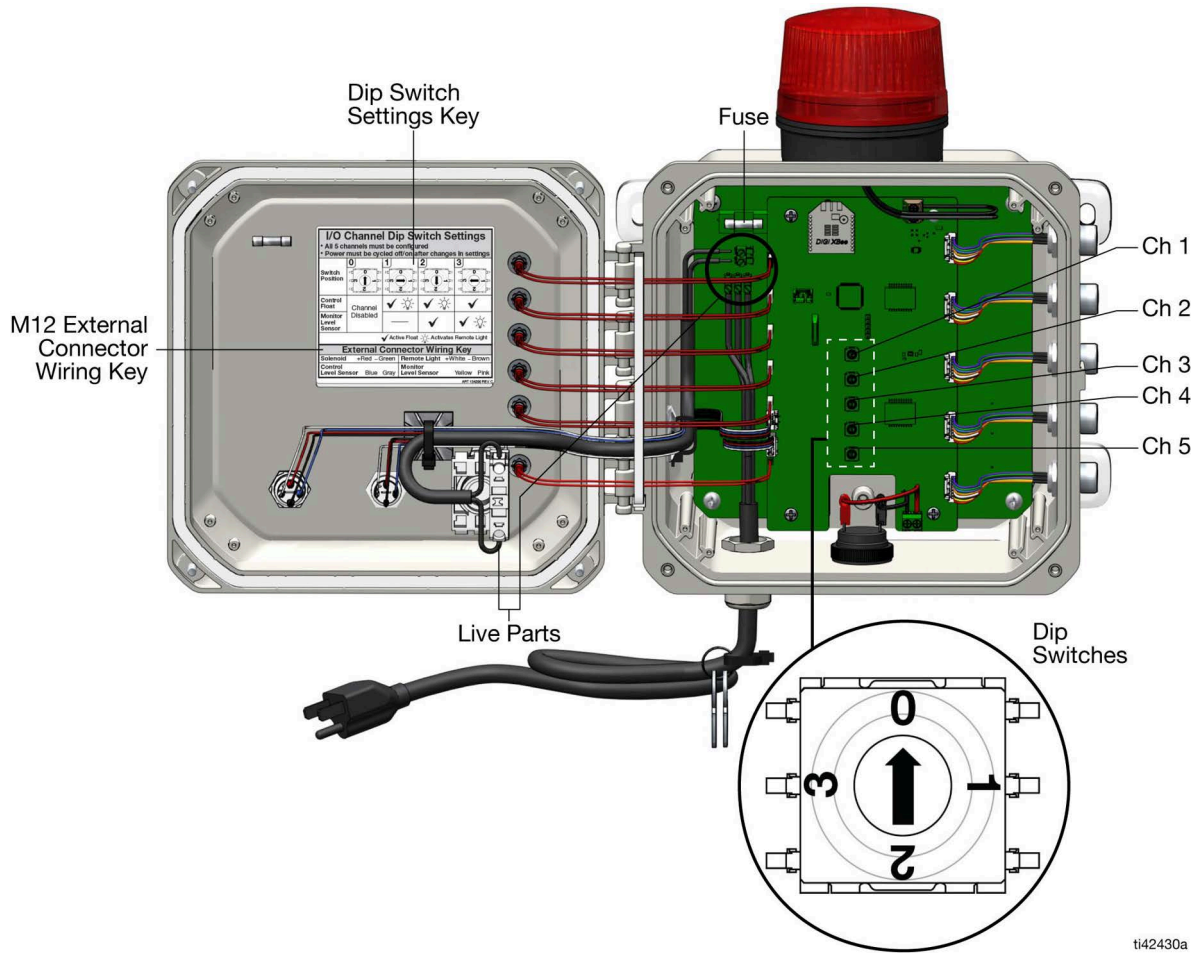

ti42430a

FIG. 5

## I/O Channel Dip Switch Settings

Each channel has a connection for a control level sensor, a monitor level sensor, an air control solenoid valve, and a remote light.

**NOTE:** The control level sensor operates the air control solenoid valve.

Dip Switch Position 0: The channel is disabled.

Dip Switch Position 1: The control level sensor is enabled, and the monitor level sensor is disabled.

Dip Switch Position 2: Both level sensors are enabled, and the remote light circuit is activated by the control level sensor\*.

Dip Switch Position 3: Both level sensors are enabled, and the remote light circuit is activated by the monitor level sensor\*.

\*Both level sensors activate the corresponding alarm lights on the Fluid Defender when in an alarm condition.

## Wire Key for M12 External Connector

|                              |        |
|------------------------------|--------|
| Air Control Solenoid Valve + | red    |
| Air Control Solenoid Valve - | green  |
| Remote Light +               | white  |
| Remote Light -               | brown  |
| Control Level Sensor         | blue   |
|                              | gray   |
| Monitor Level Sensor         | yellow |
|                              | pink   |

**NOTE:** When shielded cable is used, the shield must be connected to either the blue or pink wire of the M12 External Connector.

# Overview

## Definitions

**Fluid Defender:** An electronic device that monitors fluid tank levels utilizing level sensors for overflow protection. Regulates air powered connected equipment using air control solenoid valves.

**Control Level Sensor:** A level sensor that monitors the tank fluid level. The output to the Fluid Defender controls pumps and air actuated control valves using air control solenoid valves. Either a high level or a low level sensor may be connected as a control level sensor.

**Monitor Level Sensor:** A level sensor that monitors the tank fluid level. Either a high level or a low level sensor may be connected as a monitor level sensor.

**Remote Light (optional):** A panel mounted light that indicates alarm status remotely. It can be configured to be activated either by the control level sensor or the monitor level sensor.

**Channel:** Independent circuits that monitor separate tanks or control separate air control solenoid valves. Each channel has an I/O connection for an air control solenoid valve, a remote light, a control level sensor, and a monitor level sensor. The equipment is grouped into a single channel to provide the desired functionality.

**NOTE:** Each channel is limited to one air control solenoid valve and one remote light.

**Remote Bulk Fill Stop:** A design configuration where an air actuated control valve stops the flow of fluid into a tank during filling.

**NOTE:** Use only tight-fill connections between the delivery hose and the tank fill piping for piping systems with mechanically actuated overflow valves. Loose-fill connections may cause fill piping spills at the delivery hose connection point.

**Waste Oil High Level Shut Off:** A design configuration where an air control solenoid valve controls an AODD pump to stop the flow of waste oil into a tank.

**Low Level Pump Runaway:** Controls, and shuts down, a fluid distribution pump in case of a low tank level to prevent pump cavitation, runaway, and pump damage.

**Controlled Equipment:** User supplied devices operated by an air control solenoid valve. Typical devices include AODD pumps for waste oil evacuation, air operated lube distribution pumps for bulk oil dispense, and an air actuated control valve for remote bulk fill stop.

## Air Control Solenoid Valves

Air control solenoid valves are a system component used to control air operated pumps and air actuated control valves. These devices are used to stop fluid flow into the monitored tank. They are an optional system component, but required for fluid flow interruption.

The air control solenoid valves are continuously powered during normal operation with the air control solenoid valve being open to provide air pressure to the controlled equipment.

The Fluid Defender must be powered for the air control solenoid valve to be open, allowing for normal controlled equipment operation. Loss of power to the Fluid Defender closes the air control solenoid valve and bleeds downstream air pressure from the controlled equipment.

## Fluid Level Sensors

The fluid level sensors detect the tank fluid level and signals the Fluid Defender to activate the alarm and deactivate the air control solenoid valve (if configured on the specific channel).

**Control level sensor:** A level sensor that monitors a tank fluid level. The output to the Fluid Defender controls pumps and air actuated control valves using air control solenoid valves. Either a high level or a low level sensor may be connected as a control level sensor.

**Monitor level sensor:** A level sensor that monitors a tank fluid level. Either a high level or a low level sensor may be connected as a monitor level sensor.

**NOTE:** Level sensors are preconfigured at the factory. Do not attempt to reconfigure a level sensor by changing the float orientation. High level sensors are unable to be configured into low level sensors, and low level sensors are unable to be configured into high level sensors.

## High Level Sensors

The float is in the down position and the sensor contacts are closed during normal operation (FIG. 6, illustration a).

The float moves to the up position and the sensor contacts are open during a high level condition, triggering the Fluid Defender alarm (FIG. 6, illustration b).

## Low Level Sensors

The float is in the up position and the sensor contacts are closed during normal operation (FIG. 6, illustration c).

The float moves to the down position and the sensor contacts are open during a low level condition, triggering the Fluid Defender alarm (FIG. 6, illustration d).

**NOTE:** For clarity, FIG. 6 does not show the splash guard.

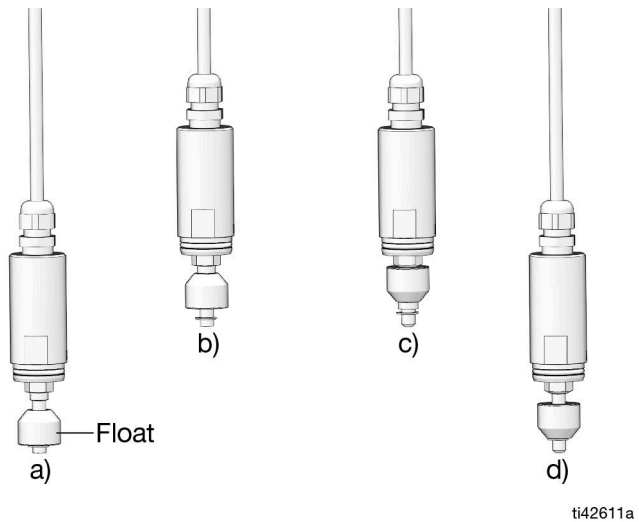

**FIG. 6**

# Installation

|   |  |  |  |  |
|---|--|--|--|--|
|   |  |  |  |  |
| <b>COMPONENT RUPTURE HAZARD</b>   |  |  |  |  |
| <p>The air actuated control valve, and all of the fill piping and connections between the air actuated control valve and the fluid delivery pump, must be designed for use with pumped delivery, and be able to handle the maximum pressure produced when the pump continues to operate after the air actuated control valve closes.</p> <p>The maximum working pressure of the components in the fill piping may vary. Over pressurization of any component may cause them to rupture, resulting in property damage and serious injury, such as skin injection, or injury from splashing fluid.</p> <p>To reduce the risk of injury and property damage from component rupture:</p> <ul style="list-style-type: none"> <li>• Be sure to know the maximum working pressure of each component in the system</li> <li>• Never exceed the maximum working pressure of any component in the system</li> <li>• Only connect fluid delivery pumps which are able to be operated with a closed outlet</li> <li>• Only connect fluid delivery pumps with a maximum outlet pressure lower than the maximum rated pressure of the system</li> </ul> |  |  |  |  |

## Pressure Relief Procedure

|   |  |  |  |  |
|---|--|--|--|--|
|   |  |  |  |  |
|   |  |  |  |  |
| <p>The equipment connected to the air control solenoid valves may stay pressurized until pressure is relieved. To help prevent serious injury from pressurized fluid, such as skin injection, splashing fluid, and moving parts, follow the Pressure Relief Procedure for the connected equipment when you stop dispensing and before cleaning, checking, or servicing the equipment.</p> |  |  |  |  |

1. Turn off the bleed-type master air valve located upstream of all connected equipment.
2. Turn the Fluid Defender keyed power control off to de-energize the connected air control solenoid valves.
3. Follow the pressure relief procedure for all connected equipment, such as pumps and dispense valves from your component instruction manuals.

## Fluid Defender

Mount the Fluid Defender on a vertical wall, in a location appropriate for alarm notification and where it can be manually reset.

**NOTE:** Use a single dedicated circuit to prevent accidental power loss.

**NOTE:** Outdoor installations require an outdoor rated plug and receptacle.

Connect M12 Channel cable assemblies to connected equipment wires. Each M12 channel cable assembly is configured as a single channel, refer to the installation instructions. Reference **Wire Key for M12 External Connector**, page 10.

**NOTE:** Installations require that the spliced connections between the M12 external connectors and the wires from all of the connected equipment be sealed connections or be routed through an appropriate IP rated conduit or junction box.

## Installation of Level Sensors

Install level sensors following the instructions in Fluid Defender Level Sensor manual, see **Related Manuals**, page 1.

## Installation of Air Control Solenoid Valves

Install air control solenoid valves following the instructions the Air Control Solenoid Valve for Fluid Defender manual, see **Related Manuals**, page 1.

## Installation of Remote Light (Optional)

Install the remote light into a user provided panel at the desired location. Typical locations include the waste oil collection location or the external bulk fill locations, where the bulk tanker connects to the tank fill plumbing.

| Remote Light Maximum Wire Runs |         |         |
|--------------------------------|---------|---------|
| Maximum Line Length (20 gauge) | 1000 ft | 304.8 m |
| Maximum Line Length (22 gauge) | 620 ft  | 189 m   |
| Maximum Line Length (24 gauge) | 390 ft  | 118.9 m |

All accessory circuits are low voltage (less than 48 VDC).

## Configuration of Fluid Defender

Up to five (5) channels can be configured for each Fluid Defender.

1. Each channel is limited to one air control solenoid valve and one remote light.
2. Each channel can accommodate two level sensors, one control level sensor, and one monitor level sensor.
  - a. A control level sensor provides input for the air solenoid control valve. Either a high level or a low level sensor may be connected as a control

level sensor. Use a high level sensor to control tank overfill or a low level sensor for runaway prevention.

- b. A monitor level sensor provides secondary monitoring on the same tank, if needed.
3. Group the level sensors, air control solenoid valve, and remote light associated with a single tank on single channels by wiring to a single M12 connector.
4. Multiple channels can be used, if needed, to control remote bulk fill stop and control low fluid level pump runaway on a single tank.

Dual level sensors can be connected to two separate channels, if needed.

5. The channel dip switch setting can be configured within the Fluid Defender. See **I/O Channel Dip Switch Settings**, page 10.

- a. Most channels will be at Switch Position 1.

- b. Use Switch Position 2 and Switch Position 3 when two level sensors are connected to one channel. These two switch positions are used to select which level sensor activates the remote light.

Use Switch Position 2 when the level sensor, connected as the Control Sensor, activates the remote light.

Use Switch Position 3 when the level sensor, connected as the Monitor Sensor, activates the remote light.

Two Examples:

Example 1: On a single channel, the high level sensor is connected as the control sensor, the low level sensor is connected as the monitor sensor, and the air control solenoid valve and the remote light are both connected. The air control solenoid valve operates the air actuated control valve to manage fluid flow into the tank from the remote fill piping. The remote light is located in the tank room to indicate a low level distribution pump runaway condition (similar to FIG. 3, page 8).

Example 2: On a single channel, the low level sensor is connected as the control sensor, the high level sensor is connected as the monitor sensor, and the air control solenoid valve and remote light are both connected. The air control solenoid valve operates the distribution pump to prevent pump runaway. The remote light is located at the external bulk oil fill point to monitor when the tank is full (similar to FIG. 2, page 7).

- c. If a dual level sensor is connected to a channel and there are no remote lights, Switch Position 2 or Switch Position 3 may be used.

**NOTE:** The control sensor manages the air control solenoid valve and the monitor sensor controls the opposite level. Both sensors will activate an alarm.

- 6. Configure unused channels to Switch Position 0.
- 7. Connect external M12 cable assemblies to the desired I/O channel to the side of the Fluid Defender (see FIG. 4, page 9).

**NOTE:** Best Practice is to identify the fluid / tank with each channel on the front cover using a marker.

- 8. Leave caps on unused M12 I/O channels to retain the IP rating.
- 9. Close the Fluid Defender cover and tighten the cover retaining screws to the side of the cover.
- 10. Plug the Fluid Defender into a power outlet. See **Technical Specifications**, page 32, for ratings.

**NOTE:** Outdoor installations require an outdoor rated plug and receptacle.

## Register the Fluid Defender (Models 25V471 and 25V480)

| NOTICE  |
|---|
| <p>The Fluid Defender is unable to monitor tanks during PULSE Registration. Perform the pressure relief procedure to prevent tank overflows during PULSE Registration.</p> <p>Resolve alarm conditions before beginning PULSE Registration. If this is not done, the Fluid Defender cannot monitor the sensors or check for over-current conditions and may result in tank overflows.</p> |

- 1. Relieve pressure following **Pressure Relief Procedure**, page 13.
- 2. Turn on the PULSE Fluid Management Software to DISCOVERY mode.

**NOTE:** See PULSE Fluid Management, Register Your Devices quick guide, reference **Related Manuals**, page 1.

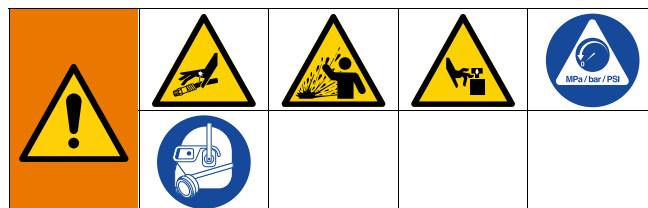

### **AUTOMATIC SYSTEM ACTIVATION HAZARD**

Unexpected activation of the air control solenoid valves could result in serious injury from connected equipment. The Fluid Defender manages the connected air control solenoid valve that opens the air supply to connected equipment when the Fluid Defender is powered,

Before installing, testing, or removing the Fluid Defender, or any of its components, relieve pressure following **Pressure Relief Procedure**, page 13.

- 3. Insert the key and turn on the keyed power control on the Fluid Defender.
- 4. Press the PULSE button on the Fluid Defender (see FIG. 4, page 9).
- 5. Registration is complete after the blue light stops flashing and remains solid. This could take from one (1) to three (3) minutes.
- 6. PULSE configurations are performed within the PULSE Fluid Management software.

# Operation







**NOTE:** This system is not a replacement for qualified and trained personnel, on-site tank fill procedures, maintenance, inspection, and testing of properly installed equipment.

Tank installation and operation must meet all laws and regulations, including without limitation, overflow containment requirements. The Fluid Defender does not satisfy, negate, or replace these regulations.

Determine and verify that there is sufficient volume available in the tank before transfer. Verify capacity before filling any tank.

**NOTE:** Refer to PEI RP600 Recommended Practices for Overflow Prevention for Shop-Fabricated Above Ground Tanks to develop site specific tank fill procedures ([www.pei.org](http://www.pei.org)).

## Test System

|   |  |  |  |  |
|---|--|--|--|--|
|   |  |  |  |  |
|  |  |  |  |  |

**AUTOMATIC SYSTEM ACTIVATION HAZARD**  
 Unexpected activation of the air control solenoid valves could result in serious injury from connected equipment. The Fluid Defender manages the connected air control solenoid valves that open the air supply to connected equipment when the Fluid Defender is powered,  
 Before installing, testing, or removing the Fluid Defender, or any of its components, relieve pressure following **Pressure Relief Procedure**, page 13.

**NOTE:** Ensure that all air control solenoid valves are not in the override mode. Air control solenoid valves in override mode are unable to control downstream equipment.

Develop on-site tank fill procedures to prevent accidental overfills.

Test the alarms before any remote bulk fill is performed.

Determine and verify there is sufficient volume available in the tank before transfer. Verify capacity before filling any tank.

Test the complete installed system to verify correct installation.

Follow maintenance requirements and perform periodic system maintenance.

1. Relieve pressure following **Pressure Relief Procedure**, page 13.
  2. Insert the key into the keyed power control and turn to the left to power down the Fluid Defender. Verify power is off.
  3. Verify that the air supply has been turned off on all connected equipment to prevent unexpected activation.
  4. Insert the key into the keyed power control and turn to the right to power the Fluid Defender.
- NOTE:** Cycle the power on and off after changes to the dip switch settings.
5. Open the bleed-type master air valves, one at a time, to the connected equipment to confirm operation.
  6. Test each individual level sensor to verify that the correct wiring connections have been made to the air control solenoid valves and remote lights.

**NOTE:** The black cylindrical splash guards on the level sensor can be removed for testing the system. The splash guards are held in place by a compression fit o-ring. Reinstall the splash guards after testing.



## High Level Sensors

The float is in the down position, normal condition, the contact is closed: no alarm (FIG. 7, illustration a).

The float is in the up position, the contact is open (FIG. 7, illustration b):

Verify the following:

- Alarms activate (siren and rotating beacon)
- Corresponding alarm light on the Fluid Defender activates
- The air control solenoid valve in the connected channel deactivates
- The remote light in the connected channel activates

## Low Level Sensors

The float is in the up position, normal condition, the contact is closed: no alarm (FIG. 7, illustration c).

The float is in the down position, the contact is open (FIG. 7, illustration d):

Verify the following:

- Alarms activate (siren and rotating beacon)
- Corresponding alarm light on the Fluid Defender activates
- The air control solenoid valve in the connected channel deactivates
- The remote light in the connected channel activates

**NOTE:** For clarity, FIG. 7 does not show the splash guard.

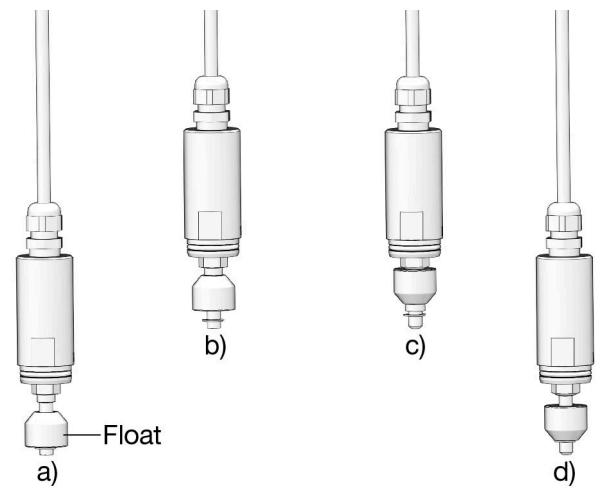

ti42611a

**FIG. 7**

## Air Control Solenoid Valve Manual Override

Only use manual override for system setup, or when instructed by Graco for troubleshooting. Always set the mode of operation back to the normal operating position.

### NOTE:

Ensure that all air control solenoid valves are not in the override mode. Air control solenoid valves in override mode are unable to control downstream equipment.

Develop on-site tank fill procedures to prevent accidental overfills.

Test the alarms before any remote bulk fill is performed.

Determine and verify that there is sufficient volume available in the tank before transfer. Verify capacity before filling any tank.

Test the complete installed system to verify correct installation.

Follow maintenance requirements and perform periodic system maintenance.

The blue manual override switch turns on the air to the downstream connected equipment and allows the equipment to function for troubleshooting and testing purposes only.

To set the blue manual override switch:

1. Insert a small, flat screwdriver into the slot of the blue manual override switch screw (FIG. 8).
2. Rotate the blue manual override switch screw clockwise 1/4 turn.

### NOTICE

Do not turn the blue manual override switch screw more than a 1/4 turn. Overturning the screw could cause it to break, rendering the unit inoperable.

3. After performing system testing or troubleshooting, reset the blue manual override switch screw to the normal operation position. Insert a small, flat screwdriver in the slotted opening and turn the blue manual override switch screw counterclockwise back to the original position (FIG. 9).

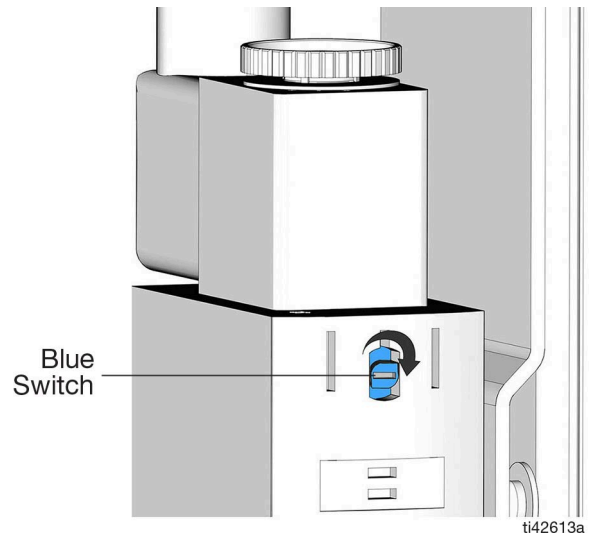

FIG. 8: Override Position

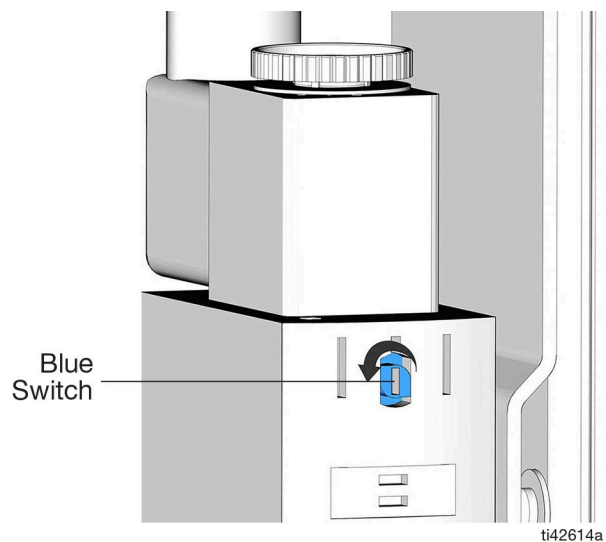

FIG. 9: Normal Operation Position

## Activate Fluid Defender

1. Reinstall all level sensors.
2. Open the bleed-type master air valve on all connected equipment, except for waste oil suction pumps which are manually activated.
3. Make sure that all air control solenoid valves are in normal operation position.
4. Turn the key to the right to power the Fluid Defender.
5. Verify that the green power light is on.

## Alarms

| Alarm                 | Description   | Result   | Solution  |
|-----------------------|---|--|---|
| Fluid Level           | A level sensor detects either a high level tank condition or a low level tank condition.                                    | Siren and rotating beacon activate.  | Deactivate the siren and rotating beacon by pressing the RESET button.  |
|                       |   | Alarm light activates for indicated channel.<br>RESET button light activates, remote light for indicated channel activates (if configured).                | Alarm light, RESET button light, and remote light deactivate when the level condition corrects and is no longer detected. (Level sensors reset with tank fluid level changes).    |
|                       |   | Air control solenoid valve in the indicated channel deactivates.   | Air control solenoid valve in the indicated channel reactivates when the level condition corrects and is no longer detected. (Level sensors reset with tank fluid level changes). |
|                       |   | PULSE button light deactivates if HUB communication is unsuccessful.   | Contact Graco.  |
| Over-Current          | An over-current situation has been detected in either the air control solenoid valve circuits or the remote light circuits. | Siren and rotating beacon activate.  | Deactivate the siren and rotating beacon by pressing the RESET button.  |
|                       |   | Alarm light activates and blinks for the indicated channel.<br>RESET button light activates, remote light for indicated channel activates (if configured). | Alarm light, RESET button light, and remote light deactivate when the over-current condition corrects and is no longer detected.  |
|                       |   | Air control solenoid valve in the indicated channel deactivates.   | Air control solenoid valve in the indicated channel reactivates when the over-current condition corrects and is no longer detected.   |
|                       |   | PULSE button light deactivates if HUB communication is unsuccessful.   | Contact Graco.  |
| Dead Short            | An internal electrical short occurs within the Fluid Defender.  | Siren and rotating beacon activate.  | RESET button has no effect.   |
|                       |   | All five (5) alarm lights blink  | Unplug device and contact Graco.  |
|                       |   | RESET button, PULSE button, and remote lights deactivate.  |   |
|                       |   | Air control solenoid valve in the indicated channel deactivates.   |   |
| Non-Recoverable Error | A non-recoverable error occurs in the Fluid Defender.   | Rotating beacon activates.   | RESET button has no effect.   |
|                       |   | Siren, alarm lights, RESET button, PULSE button, and remote lights deactivate.   | Unplug device and contact Graco.  |

## Update PULSE Firmware (Models 25V471 and 25V580)

1. Relieve pressure following **Pressure Relief Procedure**, page 13.

### NOTICE

The Fluid Defender is unable to monitor tanks during a firmware update. Perform the pressure relief procedure to prevent tank overflows during firmware updates.

Resolve alarm conditions before beginning a firmware update. If this is not done, the Fluid Defender cannot monitor the sensors or check for over-current conditions and may result in tank overflows.

2. Insert the key and turn on the keyed power control on the Fluid Defender.
3. Initiate a firmware update by pressing and holding the PULSE button for 10 seconds. The PULSE button will start blinking (see FIG. 4, page 9).

All air control solenoid valves are de-energized to disable connected equipment before a firmware update begins.

**NOTE:** A firmware update will not initiate when an alarm condition exists.

4. Update proceeds if a new firmware update is available. The PULSE LED turns off and remains off until the update is complete. The status of the update is shown at the PULSE PC Interface.

Upon completion, the Fluid Defender automatically reboots and normal operation proceeds (the air control solenoid valves are re-energized). If the Fluid Defender loses power during the update, the process resumes when power is restored.

### NOTE:

Do not power cycle the Fluid Defender during the update.

If there are no firmware updates available on the Hub, or if communication with the Hub is currently unavailable, the update attempt is terminated and normal operation resumes with the air control solenoid valves being re-energized.

5. Open the bleed-type master air valves, one at a time, to the connected equipment to confirm operation.
6. Perform the weekly periodic maintenance procedures, see **Maintenance**, page 21.

# Maintenance

## NOTICE

The Fluid Defender is unable to monitor tanks during maintenance or service. Perform the **Pressure Relief Procedure**, page 13, to prevent tank overflows during maintenance or service.

## Periodic Testing

**NOTE:** A maintenance log example is provided for tracking. See **Maintenance Log**, page 35.

### Weekly (and before every remote bulk fill)

1. Press and hold the RESET button to test the siren, rotating beacon, remote lights, and Fluid Defender alarm lights.
2. Press the RESET button to reset the alarm.

### Monthly

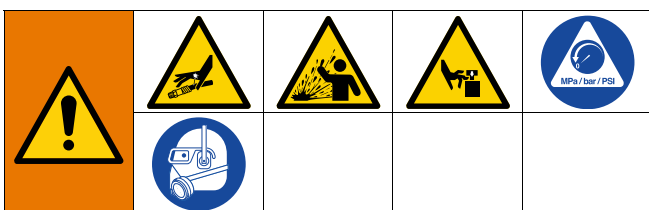

#### AUTOMATIC SYSTEM ACTIVATION HAZARD

Unexpected activation of the air control solenoid valves could result in serious injury from connected equipment. The Fluid Defender manages the connected air control solenoid valves that open the air supply to connected equipment when the Fluid Defender is powered,

Before installing, testing, or removing the Fluid Defender, or any of its components, follow the **Pressure Relief Procedure**, page 13.

1. Relieve pressure following **Pressure Relief Procedure**, page 13.
2. Remove the sensors from the tanks and manually raise or lower the level sensor to verify that the system goes into alarm mode.
3. Inspect the level sensors and remove magnetic particles from fluid contamination that may interfere with operation.
4. Manually test all of the accessories to verify they are functioning properly.

5. Confirm that all wires are properly connected to the Fluid Defender and accessories.

## NOTICE

Disable the Fluid Defender or immediately replace failed equipment upon any and all test failures. Equipment failures will not allow the Fluid Defender to monitor tank conditions and may result in a tank overflow.

## Replace Rotating Beacon Alarm



## NOTICE

The Fluid Defender is unable to monitor tanks during maintenance or service. Perform the **Pressure Relief Procedure**, page 13, to prevent tank overflows during maintenance or service.

Refer to FIG. 4, page 9 and FIG. 5, page 10 for the following sections.

1. Remove power to the Fluid Defender by turning the key to the left.
2. Unplug the power cord to the Fluid Defender.
3. Remove and retain the cover screws on the enclosure door and open.
4. Loosen the two screws on the terminal block where the red and black rotating beacon wires are attached.
5. Pull out the red and black wires.
6. Remove the red lens cover from the rotating beacon alarm.
7. Remove and retain the screws, washers, and nuts that attach the rotating beacon alarm to the Fluid Defender enclosure.
8. Replace the gasket with the one provided, if needed.
9. Punch holes in the black base of the rotating beacon alarm for the screws using a Phillips screwdriver.

Maintenance

10. Reassemble the rotating beacon alarm, screws, washers, and nuts. Tighten the screws so the gasket is compressed.
11. Replace the red lens cover onto the rotating beacon alarm.
12. Attach the leads to the terminal block. The red wire attaches to the terminal RED, and the black wire attaches to the terminal BLK.
13. Tighten the terminal screws to secure the wires.
14. Ensure a secure connection by lightly pulling on each wire.
15. Close the enclosure door and replace the cover screws.
16. Tighten the screws until the gap between the cover and enclosure is closed.

20. To test that the rotating beacon alarm is activated, press and hold the reset button.

**NOTE:** The alarm sounds when activated.

21. Press the reset button to reset the alarm.
22. Confirm operation by opening the bleed-type master air valves, one at a time, to the connected equipment.

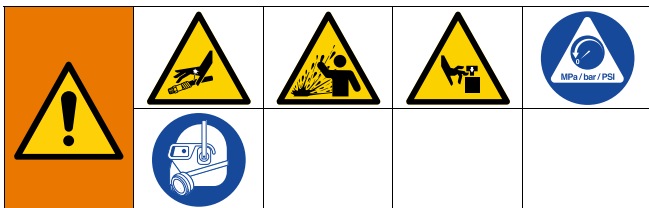

**AUTOMATIC SYSTEM ACTIVATION HAZARD**  
 Unexpected activation of the air control solenoid valves could result in serious injury from connected equipment. The Fluid Defender manages the connected air control solenoid valves that open the air supply to connected equipment when the Fluid Defender is powered,  
 Before installing, testing, or removing the Fluid Defender, or any of its components, follow the **Pressure Relief Procedure**, page 13.

17. Plug in the power cord for the Fluid Defender.
18. Return power to the Fluid Defender by turning the key to the right.
19. Verify that the power light is on.

## Replace Fuse



### NOTICE

All maintenance needs to be performed in a non-hazardous location.

The Fluid Defender is unable to monitor tanks during maintenance or service. Perform the **Pressure Relief Procedure**, page 13, to prevent tank overflows during maintenance or service.

Refer to FIG. 4, page 9 and FIG. 5, page 10 for the following sections.

1. Remove power to the Fluid Defender by turning the key to the left.
2. Unplug the power cord to the Fluid Defender.
3. Remove and retain the cover screws on the enclosure door and open.
4. Locate and remove the fuse.
5. Find the replacement fuse taped to the inside of the front cover.
6. Insert the replacement fuse.
7. Close the enclosure door and replace the cover screws.
8. Tighten the screws until the gap between the cover and enclosure is closed.

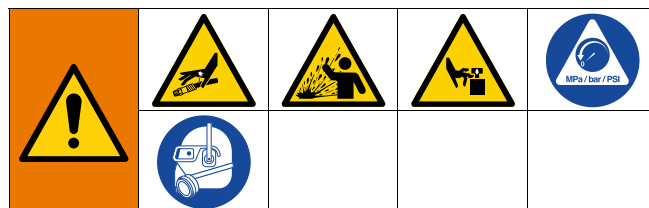

### AUTOMATIC SYSTEM ACTIVATION HAZARD

Unexpected activation of the air control solenoid valves could result in serious injury from connected equipment. The Fluid Defender manages the connected air control solenoid valves that open the air supply to connected equipment when the Fluid Defender is powered,

Before installing, testing, or removing the Fluid Defender, or any of its components, follow the **Pressure Relief Procedure**, page 13.

9. Plug in the power cord for the Fluid Defender.
  10. Return power to the Fluid Defender by turning the key to the right.
  11. Verify that the power light is on.
  12. To test that the rotating beacon alarm is activated, press and hold the reset button.
- NOTE:** The alarm sounds when activated.
13. Press the reset button to reset the alarm.
  14. Confirm operation by opening the bleed-type master air valves, one at a time, to the connected equipment.

# Recycling and Disposal

## End of Product Life

At the end of the product's useful life, dismantle and recycle it in a responsible manner.

- Remove motors, circuit boards, LCDs (liquid crystal displays) and other electronic components. Recycle according to applicable regulations.

- Do not dispose of electronic components with household or commercial waste.



- Deliver remaining product to a recycling facility.



# Troubleshooting

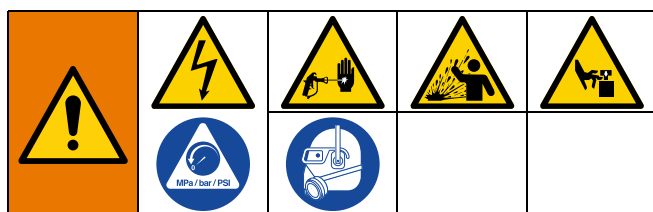

Follow **Pressure Relief Procedure**, page 13, before checking or repairing the system.

Check all possible problems and causes before disassembling system.

| Problem                              | Cause   | Solution   |
|--------------------------------------|---|--|
| High level fill shut off failure     | There is a level sensor malfunction                               | Perform maintenance on level sensors according to recommended maintenance intervals. See <b>Maintenance</b> , page 21.<br>Test level sensor and replace if needed.   |
|                                      | There is a remote light malfunction                               | Test and replace if needed   |
|                                      | Incorrect level sensor is installed                               | Confirm that a high level sensor is wired correctly as the control level sensor on the correct channel, then test (see <b>Wire Key for M12 External Connector</b> , page 10).  |
|                                      | No air control solenoid valve is installed to stop the fluid flow | Install an air control solenoid valve to stop the fluid flow, then test.   |
|                                      | Incorrect dip switch setting                                      | Verify that the dip switch setting is correct, power the controller to reconfigure, then test.   |
|                                      | Incorrect circuit wiring  | Confirm that a high level sensor is wired correctly as the control level sensor on the correct channel, check the air control solenoid valve wiring, then test see <b>Wire Key for M12 External Connector</b> , page 10).                        |
|                                      | Air control solenoid valve failure                                | Replace the air control solenoid valve, then test.   |
|                                      | Air control solenoid valve is in manual override mode             | Turn the air control solenoid valve to the normal operation position   |
|                                      | Air actuated control valve malfunction                            | Replace and test   |
|                                      | No power to the Fluid Defender.                                   | Ensure that the electrical circuit has power. A single dedicated power circuit is recommended. Verify the Fluid Defender is plugged in and that the keyed power control is turned to the right. Make sure that the power indication light is on. |
|                                      |   | Ensure the Fluid Defender is plugged in and keyed power control is turned to the right.  |
| Ensure Power indication light is on. |   |  |

| Problem  | Cause  | Solution  |
|--|--|---|
| Alarm condition indicates when fluid levels are correct          | M12 external connector is disconnected   | Reconnect to the correct channel  |
|  | Level sensor connection is severed   | Reconnect then test system  |
|  | Air control solenoid power connection is severed   |   |
|  | Over-Current   | See <b>Alarms</b> , page 19 for solution.   |
|  | Dead short   |   |
| Alarm condition does not reset when the tank fluid level adjusts | There is a level sensor malfunction  | Replace the level sensor  |
|  |  | Remove any debris from the float and stem on the level sensor, reinstall, then test.                                      |
|  | Level sensor float orientation is incorrect, floats are not able to be flipped to reconfigure level sensors from high to low, or vice versa. | Correct the float orientation then verify that the orientation matches the installation requirement. See FIG. 6, page 12. |
| The PULSE system is not sending alarm notifications              | Issue with the PULSE system set-up   | Refer to the PULSE system set-up for email notifications.   |
|  | The Fluid Defender is not registered with PULSE  | Register the Fluid Defender with the PULSE system.  |
|  | There is poor communication between the Fluid Defender and the PULSE system  | Install a PULSE remote extender.  |
|  | The antenna on the RF radio in the Fluid Defender is disconnected.   | Contact Graco Customer Service.   |

| Problem   | Cause  | Solution  |
|---|--|---|
| Runaway distribution pump   | There is a level sensor malfunction                                | Perform maintenance on level sensors according to recommend maintenance intervals. See <b>Maintenance</b> , page 21.<br>Test the level sensor and replace if needed.  |
|   | An incorrect level sensor is installed                             | Confirm that a low level sensor is wired correctly as the control level sensor on the correct channel, then test (see <b>Wire Key for M12 External Connector</b> , page 10.)  |
|   | Incorrect dip switch setting                                       | Verify that the dip switch setting is correct, power the controller to reconfigure, then test.  |
|   | Incorrect circuit wiring   | Confirm that a low level sensor is wired correctly as the control level sensor on the correct channel, check the air control solenoid valve wiring, then test (see <b>Wire Key for M12 External Connector</b> , page 10). |
|   | Air control solenoid valve failure                                 | Replace the air control solenoid valve, then test.  |
|   | Air control solenoid valve in manual override mode                 | Turn the air control solenoid valve to the normal operation position.   |
|   | The level sensor is set too low                                    | Raise the level sensor above the pump inlet.  |
| Fluid Defender is not registering with PULSE                        | PULSE system is not in discovery mode                              | Put the PULSE system into discovery mode  |
|   | Registration fails   | Power cycle the Fluid Defender and attempt registration again.  |
|   | Poor communication between the Fluid Defender and the PULSE system | Install a PULSE remote extender.  |
|   | The antenna on RF radio in the Fluid Defender is disconnected.     | Contact Graco Customer Service.   |
| Incorrect level sensor activates remote light                       | The channel dip switch settings are incorrect.                     | Cycle power on the Fluid Defender after reconfiguring the dip switch settings.  |
| The remote light is always on                                       | Incorrectly connected to the air control solenoid valve output     | Correct the connections, then test.   |
| Air control solenoid valve is always off                            | Incorrectly connected to the remote light output                   | Correct the connections, then test.   |
|   | Incorrect air control solenoid valve type                          | Change to a Normally Closed air control solenoid valve.   |
|   | Bleed-type master air valve is closed                              | Open the bleed type master air valve.   |
|   | The air control solenoid valve is incorrectly plumbed.             | Correctly connect the air control solenoid valve. See FIG. 7, page 17.  |
| Air control solenoid valve output is not controlled by level sensor | Incorrect connections  | Verify that the level sensor is connected to the control level sensor input, then test.   |

| <b>Problem</b>  | <b>Cause</b>   | <b>Solution</b>   |
|---|--|---|
| The level sensor state is always open   | Level sensor malfunction   | Replace the level sensor  |
|   | Level Sensor float orientation is incorrect, floats are not able to be flipped to reconfigure level sensors from high to low, or vice versa. | Correct the float orientation then verify that the orientation matches the installation requirement. See FIG. 6, page 12.   |
| There is fluid inside the level sensor  | The cord grip not correctly tightened  | Tighten the cord grip   |
|   | Stem o-ring is missing   | Replace the level sensor.   |
| Level sensor activation happens at lower tank levels  | The cord grip on top bung adapter is not correctly tightened and the level sensor has slipped downward.                                      | Reposition the level sensor and tighten the cord grip to finger tight plus one-half turn.   |
| A level sensor malfunctions so the level sensor contacts close at the extreme up and down position and open in the middle | Sensor was exposed to an over-current condition  | Replace the level sensor.   |
| No power to the Fluid Defender  | The circuit breaker is blown on the outlet   | Check circuit breaker panel and reset the circuit breaker.  |
|   | The unit is not plugged in   | Plug the unit into a powered outlet.  |
|   | The key is not in the on position  | Verify that the keyed power control is turned to the right Make sure that the power indication light is on.   |
|   | The fuse is blown  | <ol style="list-style-type: none"> <li>1. Replace the fuse.</li> <li>2. If the second fuse fails, the internal power supply is blown. Contact Graco Distributor.</li> </ol> |

# Parts

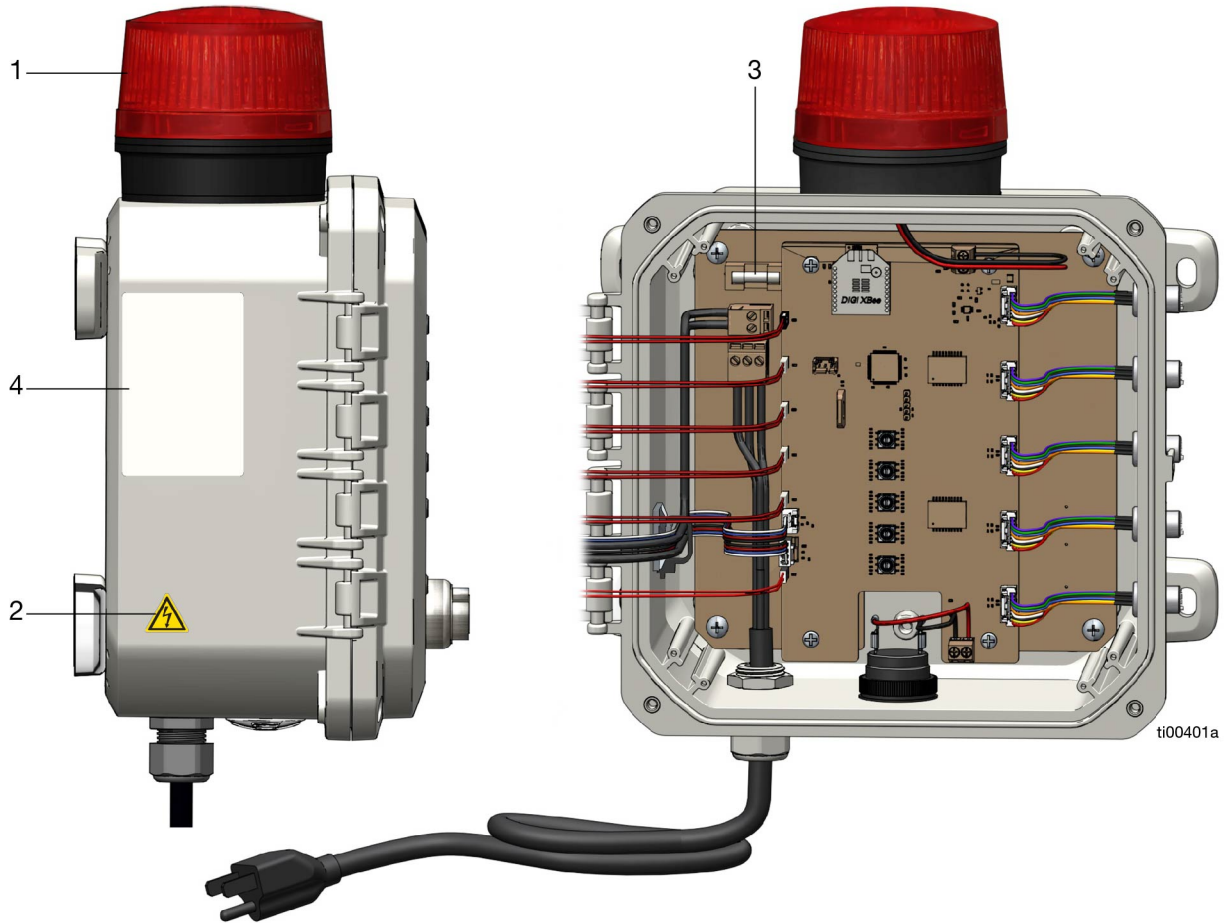

| Ref. | Part   | Description                              | Qty. |
|------|--------|--|------|
| 1    | 18G101 | Rotating Beacon                          | 1    |
| 2▲   | 189930 | Label, caution                           | 1    |
| 3    | 18G061 | Fuse (replacement taped to inside cover) | 2    |
| 4    |        | PN/SN label                              |      |

▲ Replacement safety labels, tags, and cards are available at no cost.

# Accessories

## Air Control Solenoid Valves

(required for fluid flow interruption)

P/N 25V482

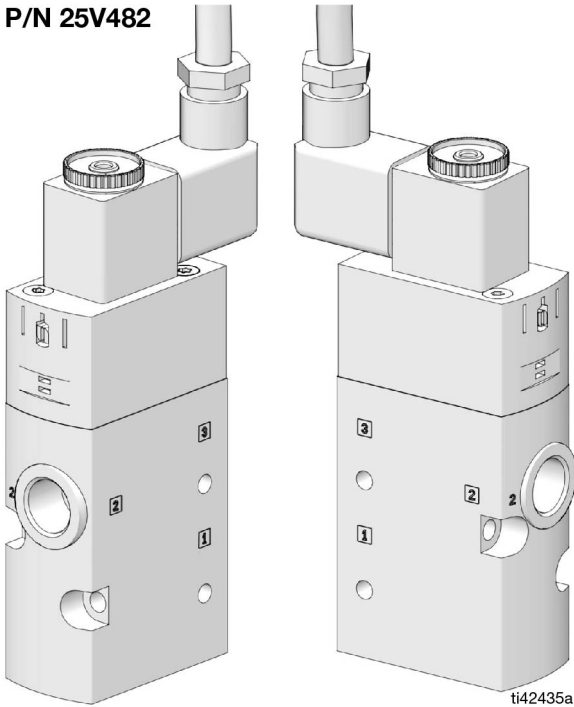

FIG. 10

## Level Sensors (Required)

High Level  
P/N 25V475

Low Level  
P/N 25V476 (10 ft, 3.05 m)  
P/N 25V477 (30 ft, 9.14 m)

Dual Level  
P/N 25V478 (10 ft, 3.05 m)  
P/N 25V479 (30 ft, 9.14 m)

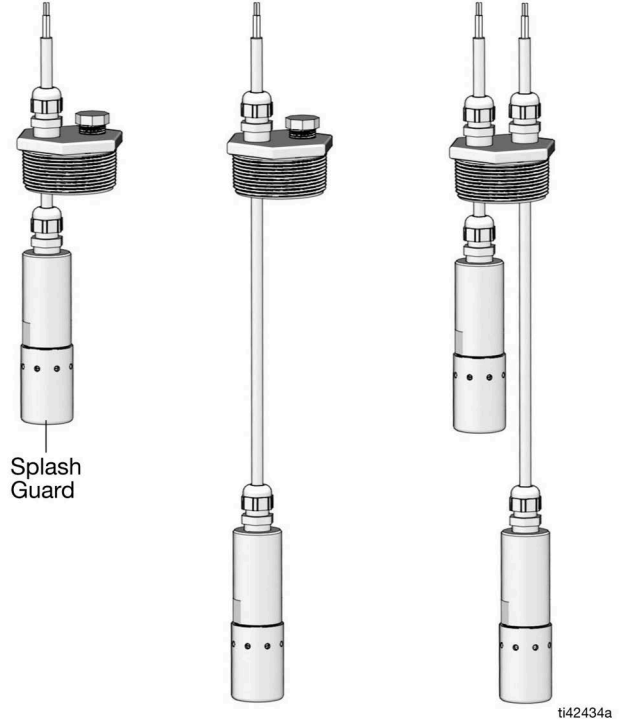
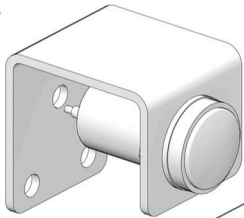

FIG. 12

## Bracket Light Kit (Optional)

P/N 18G108  
Single



P/N 18G109  
Multiple

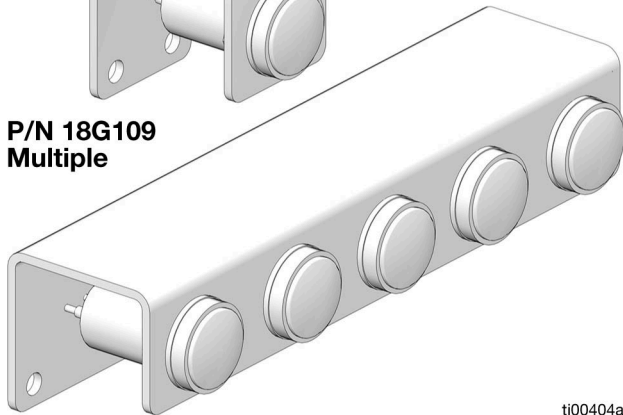

ti00404a

FIG. 11

## Remote Light (Optional)

P/N 18G060

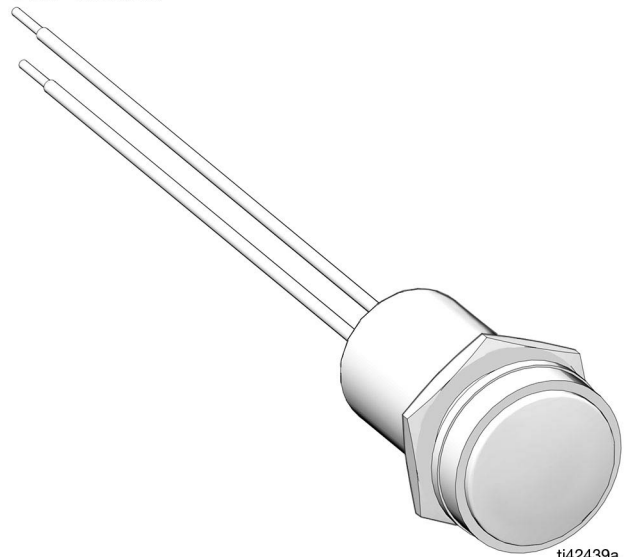

ti42439a

FIG. 13

# Dimensions

## Mounting Hole Layout

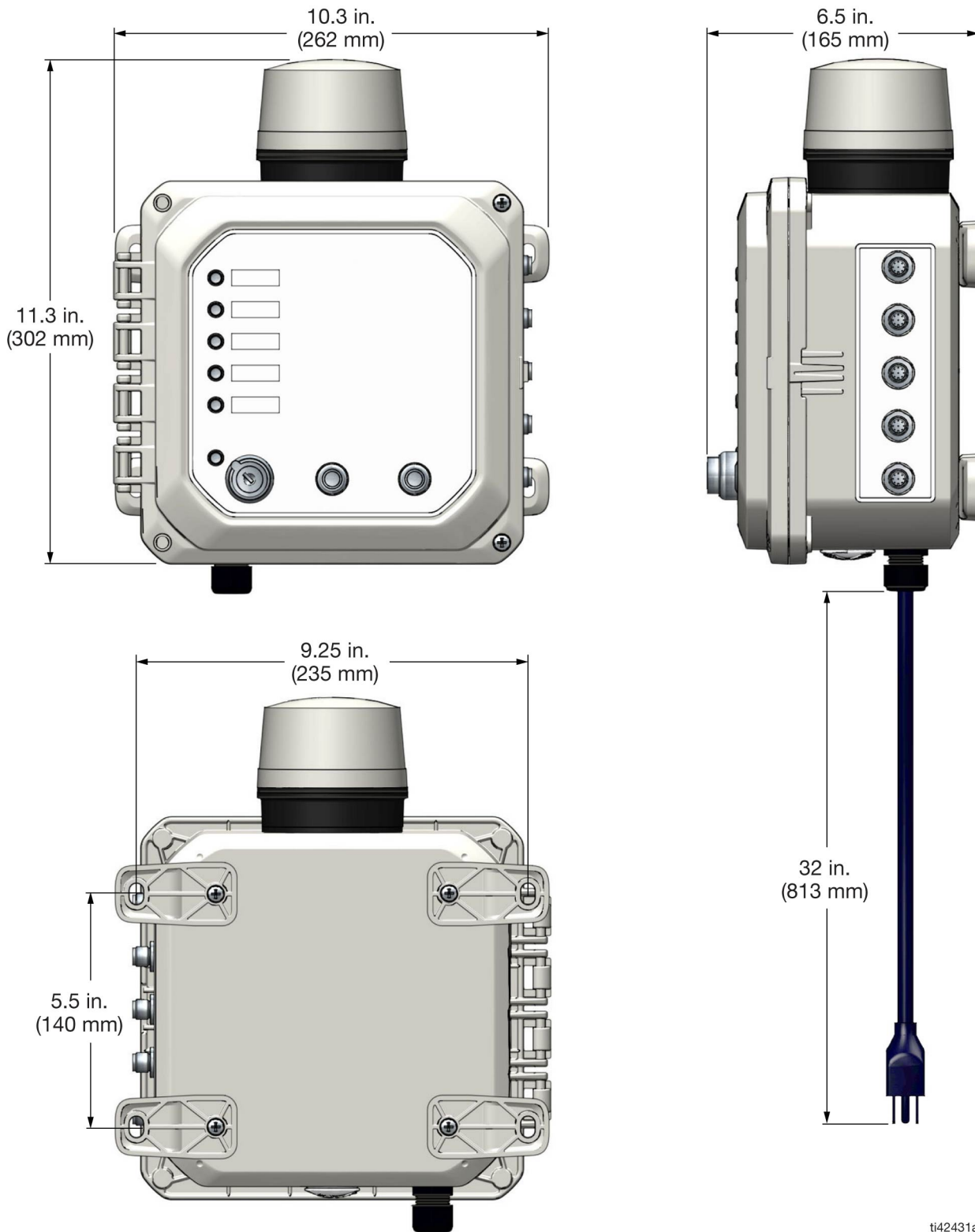

ti42431a

FIG. 14

# Technical Specifications

| <b>Fluid Defender</b>                       |                                  |               |
|---|----------------------------------|---------------|
|   | <b>US</b>                        | <b>Metric</b> |
| <b>Models 25V470 and 25V471</b>             |                                  |               |
| Voltage                                     | 120 VAC - 60 Hz                  |               |
| Current                                     | 1.8 A at 120 VAC                 |               |
| Plug Configuration                          | NEMA 5 - 15 plug                 |               |
| Siren Sound Pressure Level at 2 ft (0.61 m) | 103 dB(A)                        |               |
| Channels                                    | 5                                |               |
| Input/Output per Channel                    |                                  |               |
| Solenoid Output (red/green)                 | 24 VDC                           |               |
| Solenoid Output (red/green)                 | 0.25 A (maximum)                 |               |
| Remote Light Output (white/brown)           | 24 VDC                           |               |
| Remote Light Output (white/brown)           | 0.05 A (maximum)                 |               |
| Control Level Sensor (blue/gray)            | Open dry contacts                |               |
| Monitor Level Sensor (yellow/pink)          | Open dry contacts                |               |
| RF Frequency Band                           | 2400 - 2483.5 MHz (Model 25V471) |               |
| Maximum RF Transmit Power                   | 6.3 mW (8 dBm) (Model 25V471)    |               |
| Temperature Range                           | 14°F to 122°F                    | -10°C to 50°C |
| Storage Temperature Range                   | -40°F to 185°F                   | -40°C to 85°C |
| Ingress Protection                          | NEMA Type 3R Enclosure           |               |
| <b>Models 25V579 and 25V580</b>             |                                  |               |
| Voltage                                     | 230 VAC - 50 Hz                  |               |
| Current                                     | 1.0 A at 230 VAC                 |               |
| Termination Style                           | AS/NZS 3112 with ground          |               |
| Siren Sound Pressure Level (2 ft/0.61 m)    | 103 dB(A)                        |               |
| Channels                                    | 5                                |               |
| Input/Output per Channel                    |                                  |               |
| Solenoid Output (red/green)                 | 24 VDC                           |               |
| Solenoid Output (red/green)                 | 0.25 A (maximum)                 |               |
| Remote Light Output (white/brown)           | 24 VDC                           |               |
| Remote Light Output (white/brown)           | 0.05 A (maximum)                 |               |
| Control Level Sensor (blue/gray)            | Open dry contacts                |               |
| Monitor Level Sensor (yellow/pink)          | Open dry contacts                |               |
| RF Frequency Band                           | 2400 - 2483.5 MHz (Model 25V580) |               |
| Maximum RF Transmit Power                   | 6.3 mW (8 dBm) (Model 25V580)    |               |
| Temperature Range                           | 14°F to 122°F                    | -10°C to 50°C |
| Storage Temperature Range                   | -40°F to 185°F                   | -40°C to 85°C |
| Ingress Protection                          | NEMA Type 3R Enclosure           |               |



# Accessory Requirements

| Air Control Solenoid Valve Requirements  |  |
|--|--|
| Operating Power  | 3.3W   |
| Voltage  | 24 VDC   |
| Current  | 0.14A  |
| Termination Style  | Wire leads   |
| Valve Schematic  |  |
| Level Sensor Module Requirements   |  |
| Type   | Single/Dual Point Magnetic Level Sensor/Reed Switch            |
| High Level   | Normally closed - open on the rise                             |
| Low Level  | Normally closed - open on the fall                             |
| Maximum Voltage  | 24 VDC   |
| Maximum Current  | 20 mA  |
| Remote Light Requirements  |  |
| Voltage  | 24 VDC   |
| Current  | 20 mA  |
| Air Actuated Control Valve (Requirements)  |  |
| Actuation  | Normally closed/air pressure to open<br>Spring return to close |
| Notes  |  |
| All trademarks or registered trademarks are the property of their respective owners. |  |

## California Proposition 65

### CALIFORNIA RESIDENTS

**⚠ WARNING:** Cancer and reproductive harm – [www.P65warnings.ca.gov](http://www.P65warnings.ca.gov).

**This page is intentionally blank**

# Maintenance Log

## Weekly Alarm Test

| Week | Alarm Test * | Week | Alarm Test * | Week | Alarm Test * | Week | Alarm Test * |
|------|--------------|------|--------------|------|--------------|------|--------------|
| 1    |              | 14   |              | 27   |              | 40   |              |
| 2    |              | 15   |              | 28   |              | 41   |              |
| 3    |              | 16   |              | 29   |              | 42   |              |
| 4    |              | 17   |              | 30   |              | 43   |              |
| 5    |              | 18   |              | 31   |              | 44   |              |
| 6    |              | 19   |              | 32   |              | 45   |              |
| 7    |              | 20   |              | 33   |              | 46   |              |
| 8    |              | 21   |              | 34   |              | 47   |              |
| 9    |              | 22   |              | 35   |              | 48   |              |
| 10   |              | 23   |              | 36   |              | 49   |              |
| 11   |              | 24   |              | 37   |              | 50   |              |
| 12   |              | 25   |              | 38   |              | 51   |              |
| 13   |              | 26   |              | 39   |              | 52   |              |

## Monthly Inspections

| Month | Level Sensor ** | Air Control Solenoid Valves *** | Wire Inspection and Verification **** |
|-------|-----------------|---------------------------------|---------------------------------------|
| Jan   |                 |                                 |                                       |
| Feb   |                 |                                 |                                       |
| Mar   |                 |                                 |                                       |
| Apr   |                 |                                 |                                       |
| May   |                 |                                 |                                       |
| Jun   |                 |                                 |                                       |
| Jul   |                 |                                 |                                       |
| Aug   |                 |                                 |                                       |
| Sep   |                 |                                 |                                       |
| Oct   |                 |                                 |                                       |
| Nov   |                 |                                 |                                       |
| Dec   |                 |                                 |                                       |

\* **Alarm Test** - Siren, Rotating Beacon, Panel and Remote Alarm Lights.

\*\* **Level Sensor** - Confirm change in normal state of the level sensor opens the circuit and activates the alarm, inspect and clean.

\*\*\* **Air Control Solenoid Valves** - Confirm alarm status in configured channel isolates the air pressure from the connected equipment.

\*\*\*\* **Wire Inspection and Verification** - Inspect wiring for damage and potential shorts. Repair if necessary.

ti00405a

**This page is intentionally blank**

# Graco Standard Warranty

Graco warrants all equipment referenced in this document which is manufactured by Graco and bearing its name to be free from defects in material and workmanship on the date of sale to the original purchaser for use. With the exception of any special, extended, or limited warranty published by Graco, Graco will, for a period of twelve months from the date of sale, repair or replace any part of the equipment determined by Graco to be defective. This warranty applies only when the equipment is installed, operated and maintained in accordance with Graco's written recommendations.

This warranty does not cover, and Graco shall not be liable for general wear and tear, or any malfunction, damage or wear caused by faulty installation, misapplication, abrasion, corrosion, inadequate or improper maintenance, negligence, accident, tampering, or substitution of non-Graco component parts. Nor shall Graco be liable for malfunction, damage or wear caused by the incompatibility of Graco equipment with structures, accessories, equipment or materials not supplied by Graco, or the improper design, manufacture, installation, operation or maintenance of structures, accessories, equipment or materials not supplied by Graco.

This warranty is conditioned upon the prepaid return of the equipment claimed to be defective to an authorized Graco distributor for verification of the claimed defect. If the claimed defect is verified, Graco will repair or replace free of charge any defective parts. The equipment will be returned to the original purchaser transportation prepaid. If inspection of the equipment does not disclose any defect in material or workmanship, repairs will be made at a reasonable charge, which charges may include the costs of parts, labor, and transportation.

**THIS WARRANTY IS EXCLUSIVE, AND IS IN LIEU OF ANY OTHER WARRANTIES, EXPRESS OR IMPLIED, INCLUDING BUT NOT LIMITED TO WARRANTY OF MERCHANTABILITY OR WARRANTY OF FITNESS FOR A PARTICULAR PURPOSE.**

Graco's sole obligation and buyer's sole remedy for any breach of warranty shall be as set forth above. The buyer agrees that no other remedy (including, but not limited to, incidental or consequential damages for lost profits, lost sales, injury to person or property, or any other incidental or consequential loss) shall be available. Any action for breach of warranty must be brought within two (2) years of the date of sale.

**GRACO MAKES NO WARRANTY, AND DISCLAIMS ALL IMPLIED WARRANTIES OF MERCHANTABILITY AND FITNESS FOR A PARTICULAR PURPOSE, IN CONNECTION WITH ACCESSORIES, EQUIPMENT, MATERIALS OR COMPONENTS SOLD BUT NOT MANUFACTURED BY GRACO.** These items sold, but not manufactured by Graco (such as electric motors, switches, hose, etc.), are subject to the warranty, if any, of their manufacturer. Graco will provide purchaser with reasonable assistance in making any claim for breach of these warranties.

In no event will Graco be liable for indirect, incidental, special or consequential damages resulting from Graco supplying equipment hereunder, or the furnishing, performance, or use of any products or other goods sold hereto, whether due to a breach of contract, breach of warranty, the negligence of Graco, or otherwise.

## **FOR GRACO CANADA CUSTOMERS**

The Parties acknowledge that they have required that the present document, as well as all documents, notices and legal proceedings entered into, given or instituted pursuant hereto or relating directly or indirectly hereto, be drawn up in English. Les parties reconnaissent avoir convenu que la rédaction du présente document sera en Anglais, ainsi que tous documents, avis et procédures judiciaires exécutés, donnés ou intentés, à la suite de ou en rapport, directement ou indirectement, avec les procédures concernées.

## Graco Information

For the latest information about Graco products, visit [www.graco.com](http://www.graco.com).

For patent information, see [www.graco.com/patents](http://www.graco.com/patents).

**TO PLACE AN ORDER**, contact your Graco distributor or call to identify the nearest distributor.

**Phone:** 612-623-6928 **or Toll Free:** 1-800-533-9655, **Fax:** 612-378-3590

*All written and visual data contained in this document reflects the latest product information available at the time of publication.  
Graco reserves the right to make changes at any time without notice.*

Original instructions. This manual contains English. MM

**Graco Headquarters:** Minneapolis

**International Offices:** Belgium, China, Japan, Korea

**GRACO INC. AND SUBSIDIARIES • P.O. BOX 1441 • MINNEAPOLIS MN 55440-1441 • USA**  
**Copyright 2023, Graco Inc. All Graco manufacturing locations are registered to ISO 9001.**

[www.graco.com](http://www.graco.com)  
Revision A, October 2023