

## SaniForce® 3250 High Sanitation Diaphragm Pump

3A6783D  
EN

For use in sanitary applications. Not approved for use in European explosive atmosphere locations. For professional use only.



### Important Safety Instructions

Read all warnings and instructions in this manual. **Save these instructions.**

*100 psi (0.7 MPa, 6.9 bar) Maximum  
Fluid Working Pressure  
100 psi (0.7 MPa, 6.9 bar) Maximum Air  
Input Pressure*

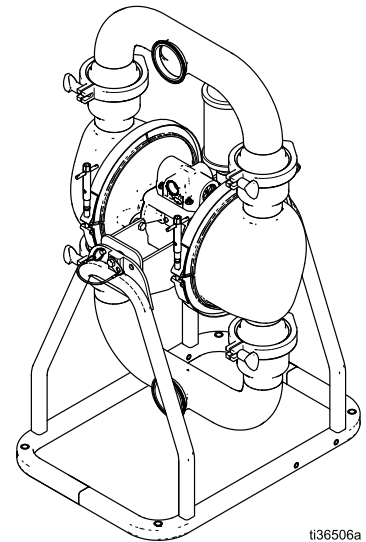

t136506a

# Contents



Related Manuals .....	2	Standard Diaphragm Repair .....	13
Warnings .....	3	Overmolded Diaphragm Repair.....	15
Configuration Number Matrix.....	5	Center Section Repair .....	18
Ordering Information .....	6	Leak Detectors .....	19
Troubleshooting.....	7	Parts.....	20
Repair.....	9	Diaphragms .....	25
Pressure Relief Procedure.....	9	Technical Specifications.....	28
Repair or Replace Air Valve.....	9	Graco Standard Warranty.....	30
Check Valve Repair .....	12		







## Related Manuals

Manual Number	Title
3A6779	SaniForce High Sanitation Diaphragm Pumps, Operation

# Warnings

The following warnings are for the setup, use, grounding, maintenance, and repair of this equipment. The exclamation point symbol alerts you to a general warning and the hazard symbols refer to procedure-specific risks. When these symbols appear in the body of this manual or on warning labels, refer back to these Warnings. Product-specific hazard symbols and warnings not covered in this section may appear throughout the body of this manual where applicable.

 <h1 style="margin: 0;">WARNING</h1>	
	<p><b>FIRE AND EXPLOSION HAZARD</b></p> <p>Flammable fumes, such as solvent, in <b>work area</b> can ignite or explode. Solvent flowing through the equipment can cause static sparking. To help prevent fire and explosion:</p> <ul style="list-style-type: none"> <li>• Use equipment only in well ventilated area.</li> <li>• Eliminate all ignition sources; such as pilot lights, cigarettes, portable electric lamps, and plastic drop cloths (potential static sparking).</li> <li>• Ground all equipment in the work area. See <b>Grounding</b> instructions.</li> <li>• Keep work area free of debris, including solvent, rags and gasoline.</li> <li>• Do not plug or unplug power cords, or turn power or light switches on or off when flammable fumes are present.</li> <li>• Use only grounded fluid lines.</li> <li>• <b>Stop operation immediately</b> if static sparking occurs or you feel a shock. Do not use equipment until you identify and correct the problem.</li> <li>• Keep a working fire extinguisher in the work area.</li> <li>• Route exhaust away from all ignition sources. If diaphragm ruptures, fluid may be exhausted with air.</li> </ul>
	<p><b>PRESSURIZED EQUIPMENT HAZARD</b></p> <p>Fluid from the equipment, leaks, or ruptured components can splash in the eyes or on skin and cause serious injury.</p> <ul style="list-style-type: none"> <li>• Follow the <b>Pressure Relief Procedure</b> when you stop spraying/dispensing and before cleaning, checking, or servicing equipment.</li> <li>• Tighten all fluid connections before operating the equipment.</li> <li>• Check fluid lines, tubes, and couplings daily. Replace worn or damaged parts immediately.</li> </ul>

 <h1 style="margin: 0;">WARNING</h1>	
 	<p><b>EQUIPMENT MISUSE HAZARD</b></p> <p>Misuse can cause death or serious injury.</p> <ul style="list-style-type: none"> <li>• Do not operate the unit when fatigued or under the influence of drugs or alcohol.</li> <li>• Do not exceed the maximum working pressure or temperature rating of the lowest rated system component. See <b>Technical Specifications</b> in all equipment manuals.</li> <li>• Use fluids and solvents that are compatible with equipment wetted parts. See <b>Technical Specifications</b> in all equipment manuals. Read fluid and solvent manufacturer's warnings. For complete information about your material, request Safety Data Sheet (SDS) from distributor or retailer.</li> <li>• Turn off all equipment and follow the <b>Pressure Relief Procedure</b> when equipment is not in use.</li> <li>• Check equipment daily. Repair or replace worn or damaged parts immediately with genuine manufacturer's replacement parts only.</li> <li>• Do not alter or modify equipment. Alterations or modifications may void agency approvals and create safety hazards.</li> <li>• Make sure all equipment is rated and approved for the environment in which you are using it.</li> <li>• Use equipment only for its intended purpose. Call your distributor for information.</li> <li>• Route fluid lines and cables away from traffic areas, sharp edges, moving parts, and hot surfaces.</li> <li>• Do not kink or over bend fluid lines or use fluid lines to pull equipment.</li> <li>• Keep children and animals away from work area.</li> <li>• Comply with all applicable safety regulations.</li> </ul>
	<p><b>TOXIC FLUID OR FUMES HAZARD</b></p> <p>Toxic fluids or fumes can cause serious injury or death if splashed in the eyes or on skin, inhaled, or swallowed.</p> <ul style="list-style-type: none"> <li>• Read Safety Data Sheet (SDS) to know the specific hazards of the fluids you are using.</li> <li>• Route exhaust away from work area. If diaphragm ruptures, fluid may be exhausted into the air.</li> <li>• Store hazardous fluid in approved containers, and dispose of it according to applicable guidelines.</li> </ul>
	<p><b>BURN HAZARD</b></p> <p>Equipment surfaces and fluid that's heated can become very hot during operation. To avoid severe burns:</p> <ul style="list-style-type: none"> <li>• Do not touch hot fluid or equipment.</li> </ul>
	<p><b>PERSONAL PROTECTIVE EQUIPMENT</b></p> <p>Wear appropriate protective equipment when in the work area to help prevent serious injury, including eye injury, hearing loss, inhalation of toxic fumes, and burns. This protective equipment includes but is not limited to:</p> <ul style="list-style-type: none"> <li>• Protective eyewear, and hearing protection.</li> <li>• Respirators, protective clothing, and gloves as recommended by the fluid and solvent manufacturer.</li> </ul>

# Configuration Number Matrix

Check the identification plate (ID) for the Configuration Number of your pump. Use the following matrix to define the components of your pump.

When you receive your pump, record the 9 character part number found on the shipping box (e.g., SP3F.0014): \_\_\_\_\_

Also record the configuration number on the pump ID plate to assist you when ordering replacement parts:

\_\_\_\_\_

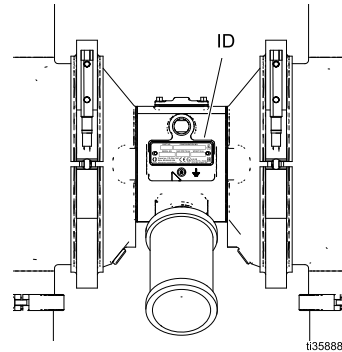

Sample Configuration Number: **3250HS.PP01ASSASSPTSPEP21**



<b>3250</b>	<b>HS</b>	<b>P</b>	<b>P01A</b>	<b>SSA</b>	<b>SS</b>	<b>PT</b>	<b>SP</b>	<b>EP</b>	<b>21</b>
Pump Model	Wetted Section Material	Drive	Center Section and Air Valve Material	Manifolds	Seats	Checks	Diaphragms	Seals	Certification

**NOTE:** Some combinations are not possible. Please check with your local supplier.

Pump	Wetted Section Material		Drive Type		Center Section and Air Valve Material		Manifolds	
<b>3250</b>	<b>3A</b>	3-A compliant	<b>P</b>	Pneumatic	<b>P01A</b>	Polypropylene	<b>SSA</b>	Stainless steel, TriClamp, horizontal
	<b>HS</b>	High Sanitation			<b>P02A</b>	Polypropylene, leak detector	<b>SSB</b>	Stainless steel, DIN, horizontal
	<b>PH</b>	Pharmaceutical			<b>P03A</b>	Polypropylene, PH		
					<b>PP1A</b>	Polypropylene, PS diaphragms		
					<b>PP2A</b>	Polypropylene, leak detector, PS diaphragms		
					<b>PP3A</b>	Polypropylene, PH, PS diaphragms		

Seat Material		Checks		Diaphragm Material		Seals		Certification	
<b>SS</b>	316 Stainless Steel, Ball	<b>BN</b>	Buna-N	<b>BN</b>	Buna-N	<b>BN</b>	Buna-N	<b>21</b>	EN 10204 type 2.1
		<b>CR</b>	Polychloroprene Ball	<b>EO</b>	EPDM Overmold	<b>EP</b>	EPDM	<b>31</b>	EN 10204 type 3.1
		<b>EP</b>	EPDM	<b>FK</b>	FKM Fluoroelastomer	<b>FK</b>	FKM		
		<b>FK</b>	FKM Fluoroelastomer Ball	<b>PS</b>	PTFE/Santoprene				
		<b>PT</b>	PTFE Ball	<b>SP</b>	Santoprene				
		<b>SP</b>	Santoprene Ball						

## Ordering Information

Approvals	
Diaphragm materials coded <b>EO</b> , <b>PO</b> , or <b>PS</b> combined with <b>PT</b> ball checks comply with:	 EC 1935/2004
Diaphragm materials coded <b>EO</b> or <b>PS</b> combined with <b>PT</b> ball checks comply with:	 Class VI
All models are approved to:	
All fluid contact materials are FDA compliant and meet the United States Code of Federal Regulations (CFR)	

## Ordering Information

### To Find Your Nearest Distributor

Visit [www.graco.com](http://www.graco.com)

### To Specify the Configuration of a New Pump

Please call your distributor.

OR

Use the Online Diaphragm Pump Selector Tool at [www.graco.com](http://www.graco.com). Search for Selector.

### To Order Replacement Parts

Please call your distributor.

# Troubleshooting



- Follow the [Pressure Relief Procedure, page 9](#) , before checking or servicing the equipment.
- Check all possible problems and causes before disassembly.

Problem	Cause	Solution
Pump cycles at stall or fails to hold pressure at stall.	Worn checks or seats.	Replace.
Pump cycles but will not prime.	Pump is running too fast, causing cavitation before prime.	Reduce air inlet pressure.
	Check valve ball severely worn or wedged in seat or manifold.	Replace ball and seat component.
	Seat severely worn.	Replace ball and seat component.
	Outlet or inlet clogged.	Unclog.
	Inlet or outlet valve closed.	Open.
	Inlet fittings or manifolds loose.	Tighten clamp.
	Manifold gaskets damaged.	Replace gaskets.
Pump will not cycle, or cycles once and stops.	Air valve is stuck or dirty.	Disassemble and clean air valve. Use filtered air.
	Check ball severely worn and wedged in seat or manifold.	Replace ball and seat component.
	Check valve ball is severely wedged into seat due to overpressurization.	Follow <a href="#">Pressure Relief Procedure, page 9</a> . Disassemble ball check assembly and inspect for damage.
	Clogged dispensing valve .	Follow <a href="#">Pressure Relief Procedure, page 9</a> . Clear valve.
	Pilot valve worn, damaged, or plugged.	Replace pilot valve.
	Air valve gasket damaged.	Replace gasket.
	Leak detector has activated a shut-down solenoid.	Investigate failure and reset leak detector.
	Shaft seals worn or damaged.	Replace seals.
Air bubbles in fluid.	Suction line is loose.	Tighten.
	Diaphragm ruptured.	Replace. See standard or overmolded diaphragm repair procedure.
	Loose diaphragm shaft bolt.	Tighten.
	Loose inlet manifold, damaged seal between manifold and seat, damaged gaskets.	Tighten manifold clamps or replace gaskets or seating components.

Troubleshooting

Problem	Cause	Solution
Reduced pump performance.	Clogged suction line.	Inspect; clear.
	Sticky or leaking check balls.	Clean or replace.
	Diaphragm ruptured.	Replace. See standard or overmolded diaphragm repair procedure.
	Pilot valves damaged or worn.	Replace pilot valves.
	Air valve damaged.	Replace air valve.
	Air valve gasket damaged.	Replace air valve gasket.
	Air supply erratic.	Replace air supply.
	Exhaust muffler icing.	Use drier air supply.
	Restricted exhaust.	Remove restriction.
Leak in inlet or outlet sanitary fitting.	Loose sanitary clamp.	Tighten clamp.
	Damaged or worn gasket.	Replace gasket.
	Misalignment of inlet/outlet fluid line or pipe.	Use flexible fluid lines at pump inlet and outlet.
	Gasket does not seal.	Install correct air cover gaskets for the type of diaphragms in use. See parts list for correct gaskets.
Fluid in exhaust air.	Diaphragm ruptured.	Replace. See standard or overmolded diaphragm repair procedure.
	Loose diaphragm plate.	Tighten or replace. See standard or overmolded diaphragm repair procedure.
Pump exhausts excessive air at stall.	Worn air valve cup or plate.	Replace.
	Damaged air valve gasket.	Replace gasket.
	Damaged pilot valve.	Replace pilot valves.
	Worn shaft seals.	Replace. See standard or overmolded diaphragm repair procedure.
Pump leaks air externally.	Air valve or fluid cover clamps loose.	Tighten.
	Diaphragm damaged.	Replace diaphragm.
	Air valve gasket damaged.	Replace gasket.
	Air cover gasket damaged.	Replace gasket.
Pump leaks fluid externally from joints.	Loose manifolds, damaged seal between manifold and seat, damaged gaskets.	Tighten manifold clamps or replace seats or clamps.
Chattering.	Check valve balls not seating properly/cleanly due to imbalance between fluid inlet and outlet line sizing. Noise is accentuated with light viscosity fluids.	Reduce size/diameter of inlet line relative to outlet line. Outlet line size should not exceed pump size.

# Repair

## Pressure Relief Procedure



Follow the Pressure Relief Procedure whenever you see this symbol.

<p>This equipment stays pressurized until pressure is manually relieved. To help prevent serious injury from pressurized fluid, such as splashing fluid, follow the Pressure Relief Procedure when you stop dispensing and before cleaning, checking, or servicing the equipment.</p>				

1. Close the master air valve (A) to shut off the air to the pump.
2. Open outbound fluid valve to relieve fluid pressure from the pump.
  - a. **For simple transfer applications**, open either the fluid shutoff valve (J) or the fluid drain valve (K).
  - b. **For circulating applications**, ensure that the fluid shutoff valve (J) is closed and open the fluid drain valve (K).

## Repair or Replace Air Valve

--	--	--	--	--

## Replace Complete Air Valve

1. Follow the [Pressure Relief Procedure, page 9](#).
2. Disconnect the supply air line at the motor.

3. Remove the nuts (105). Remove the air valve and gasket (103).
4. To repair the air valve, go to [Disassemble Air Valve, page 9](#). To install a replacement air valve, continue to the next step.
5. Align the new air valve gasket (103) on the center housing, then attach the air valve. Using a crisscross pattern, tighten the air valve nuts (105) to 45–55 in-lb (5–6.2 N•m).
6. Reconnect the supply air line at the motor.

## Replace Seals or Rebuild Air Valve

**NOTE:** Repair kits are available. See [Air Valve parts section](#).

## Disassemble Air Valve

--	--	--	--	--

1. Remove the air valve from the center section. Refer to steps 1-3 of [Replace Complete Air Valve, page 9](#).
2. Remove screws (104j). Remove the valve plate (104e), cup assembly (104m, 104n, 104s), spring (104l), and detent assembly (104c).
3. Pull the cup (104n) off of the base (104m). Remove the o-ring (104s) from the cup.
4. Remove the retaining ring (104k) from each end of the air valve. Use the piston (104b) to push the end cap (104g) out of one end. Remove the u-cup seal (104h). Pull the piston out the end and remove the other u-cup seal (104h). Remove the other end cap (104g) and the end cap o-rings (104f).
5. Remove the detent cam (104d) from the air valve housing (104a).

## Reassemble Air Valve

**NOTE:** If repairs involve removing fluid covers, perform the steps in [Reassemble the Overmolded Diaphragms, page 16](#), prior to reassembly of the air valve. The air valve configuration will be modified to aid fluid cover installation.

**NOTE:** Apply lithium-based grease whenever instructed to grease. Order Graco PN 111920.

1. Use all parts in the repair kits. Clean other parts and inspect for damage. Replace as needed.
2. Grease the detent cam (104d) and install into housing (104a).

3. Grease the u-cups (104h) and install on the piston with lips facing toward the center of the piston.
4. Grease both ends of the piston (104b) and the housing bore. Install the piston in the housing (104a), with the flat side toward the cup (104n). Be careful not to tear u-cups (104g) when sliding piston into housing.
5. Grease new o-rings (104f) and install on the end caps (104g). Install the end caps into the housing.
6. Install a retaining ring (104k) on each end to hold end caps in place.

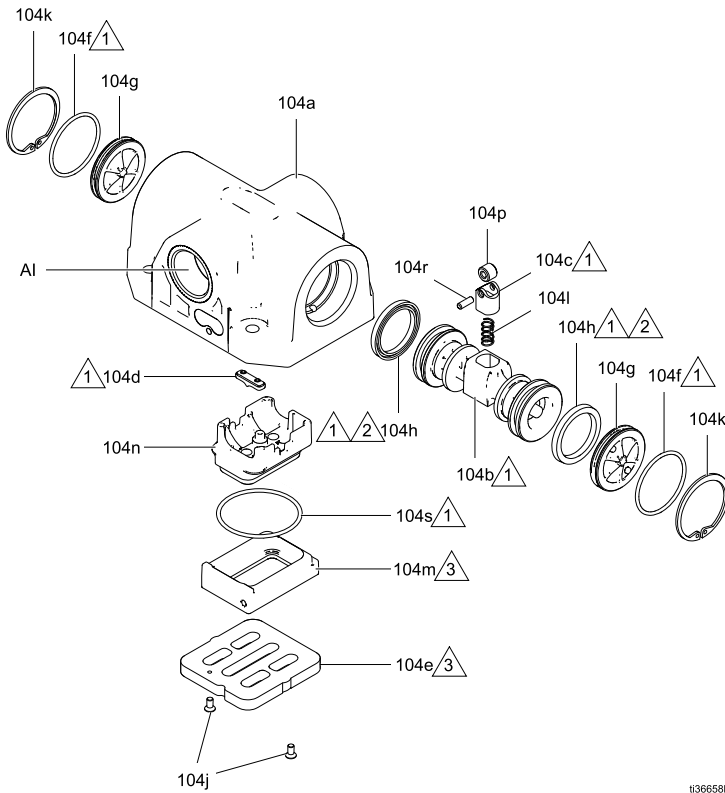

- 1 Apply lithium-based grease.
- 2 U-cup lips must face piston.
- 3 Apply lithium-based grease to contact surface.

**KEY**  
AI Air Inlet

7. Grease and install the detent assembly (104c) into the piston. Install the o-ring (104s) on the cup (104n). Apply a light film of grease to the outside surface of the o-ring and the inside mating surface of the base (104m).

Orient the end of the base that has a magnet toward the end of the cup that has the larger cutout. Engage the opposite end of the parts. Leave the end with the magnet free. Tilt the base toward the cup and fully engage the parts, using care so that the o-ring remains in place. Install the spring (104l) onto the protrusion on the cup. Align the magnet in the base with the air inlet and install the cup assembly.

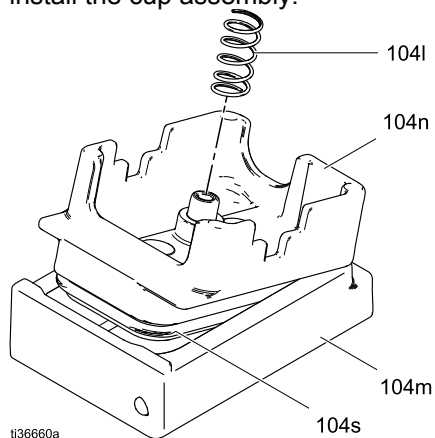

8. Grease the cup side and install the valve plate (104e). Align the small hole in the plate with the air inlet (AI). Tighten the screws (104j) to hold it in place.

## Check Valve Repair

**NOTE:** Kits are available for new check valve balls in a range of materials. Gasket kits also are available.

### Disassemble the Check Valve

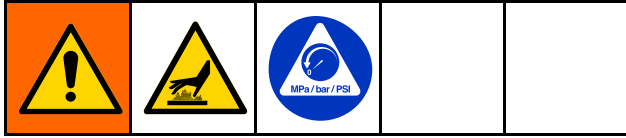

1. Follow the [Pressure Relief Procedure, page 9](#) . Disconnect all fluid and air lines.
2. To drain the pump, pull the frame quick-release pins (207) and rotate the pump. Insert the quick-release pins to prevent undesired rotation.

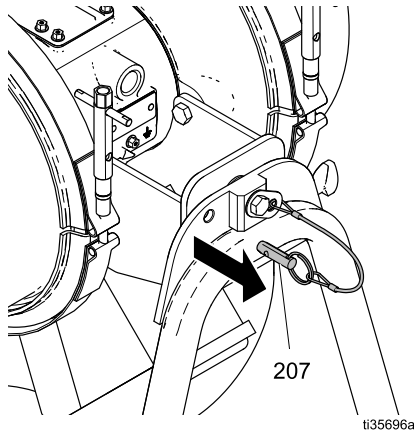

**NOTE:** After draining, rotate the pump to positions which will aid disassembly. The stand has locks at 90 degree increments.

3. Remove the clamps (23) on the outlet manifold (17) and remove the manifold.

**NOTE:** Use care while removing the outlet manifold to avoid damage to check valve components.

4. Remove remaining clamps (23), manifolds (16), gaskets (18), and check valves (19, 20).

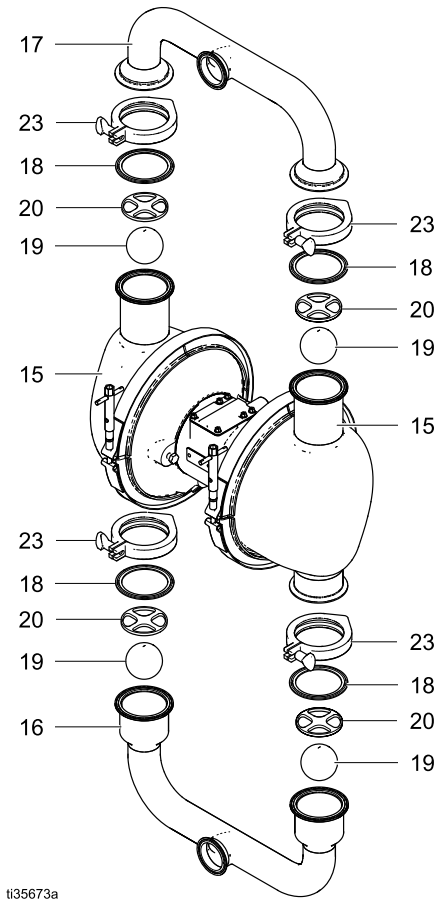

5. Clean and inspect gaskets, balls, ball stops, and seating surfaces for any damage and replace as necessary.
6. To continue with diaphragm disassembly, see [Disassemble the Standard Diaphragms, page 13](#).

### Reassemble the Check Valves

**NOTE:** Lubricate clamps, clamping surfaces, and gaskets with waterproof, sanitary lubricant.

1. Reassemble check valve components in reverse order.
2. Loosely attach the manifolds to the fluid covers. Once all components are properly aligned, tighten clamps hand tight.

## Standard Diaphragm Repair

**NOTE:** Overmolded diaphragms are covered in [Overmolded Diaphragm Repair, page 15](#).

### Tools Required:

- Torque wrench
- 18 mm wrench
- 7/8 in open end wrench
- O-ring pick
- Lithium base grease

**NOTE:** If changing diaphragm materials, center section gasket may also need to be replaced with some diaphragm types. See [Diaphragms, page 25](#), for affected air cover gaskets.

### Disassemble the Standard Diaphragms

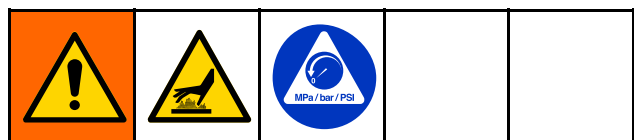

**NOTE:** Diaphragm kits are available in a range of materials and styles. See Parts section.

1. Follow the [Pressure Relief Procedure, page 9](#).
2. Remove the manifolds and disassemble the check valves as explained in [Check Valve Repair, page 12](#).
3. Remove the clamps (21) from the fluid covers (15), then pull the fluid covers off of the pump.
4. With both fluid covers removed, using two 18 mm wrenches, hold the wrench flats on the plates (Y) of each diaphragm assembly and loosen. One diaphragm assembly will come free and the other will remain attached to the shaft.
5. Disassemble the free diaphragm assembly.
6. Remove plate (12) with bolt (14) installed, diaphragm (10), backer (11) if present, and plate (9).
7. Pull the other diaphragm assembly and the diaphragm shaft (24) out of the center housing (101). Hold the shaft flats with a 7/8 in. open end wrench, and remove the diaphragm assembly from the shaft. Disassemble the remaining diaphragm assembly.
8. Inspect the diaphragm shaft (24) for wear or scratches. If it is damaged, inspect the bearings (107) in place. If the bearings are damaged, refer to [Center Section Repair, page 18](#).
9. Reach into the center housing (101) with an o-ring pick and hook the u-cups (106), then pull them out of the housing. This can be done with the bearings (107) in place.
10. Clean all parts and inspect for wear or damage. Replace parts as needed.

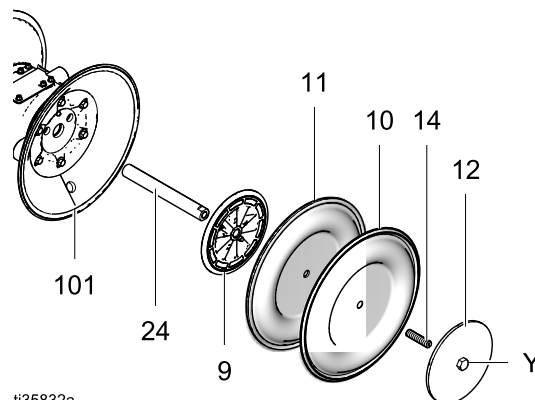

t135832a\_

## Reassemble the Standard Diaphragms

### NOTICE

After reassembly, allow the thread locker to cure for 12 hours, or per manufacturer's instructions, prior to operating the pump. Damage to the pump will occur if the diaphragm shaft bolt loosens.

**TIP:** If you are also repairing or servicing the center section, follow [Center Section Repair, page 18](#), before replacing diaphragms.

1. Lubricate and install the shaft u-cups (106) so the lips face **out** of the housing (101).
2. Assemble diaphragm (10), backer (11) if present, and plate (9) onto plate (12) with screw (14). Rounded side of plate (9) should face diaphragm. Make sure the side marked AIR SIDE faces the center housing.

**NOTE:** Thread locker must be applied to screw (14) as shown for all diaphragm assemblies.

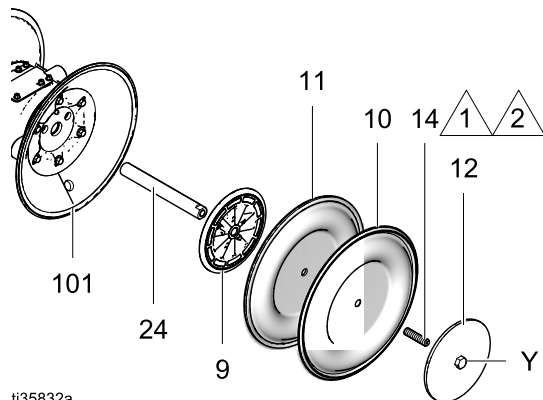

ti35832a

- 1 Apply a high-strength thread locker to attach the screw to the diaphragm plate, if needed.
- 2 Apply a medium-strength thread locker to the shaft side of the screw.

3. Screw assembled diaphragm assembly into shaft (24) and hand tighten.
4. Grease the length of the diaphragm shaft (24), and slide it through the housing (101).
5. Assemble the other diaphragm assembly to the shaft as explained in step 2.
6. Using the 18 mm wrenches hold the wrench flats of one diaphragm assembly and torque the other diaphragm to 60-70 ft-lb (81-94 N•m).

**NOTE:** Apply waterproof, sanitary lubricant to the clamp (21) and clamping surface of the cover (15) to ease assembly.

**NOTE:** Fluid cover movement may be needed when installing manifolds. Install cover clamps loose enough to allow cover movement for spacing and alignment of manifolds.

7. Align the fluid covers (15) and the center housing. Secure the covers with the clamps (21) and hand tighten.

**NOTE:** Use a food grade anti-seize lubricant on the clamp threads to aid assembly.

8. Reassemble the ball check valves and manifolds as explained in [Check Valve Repair, page 12](#)

## Overmolded Diaphragm Repair

### Tools Required:

- Torque wrench
- 7/8 in. open end wrench
- O-ring pick
- Diaphragm install tool (16G876)
- Lithium base grease

**NOTE:** If changing diaphragm materials, center section gasket may also need to be replaced with some diaphragm types. See [Diaphragms, page 25](#), for affected fluid and air lines.

### Disassemble the Overmolded Diaphragms

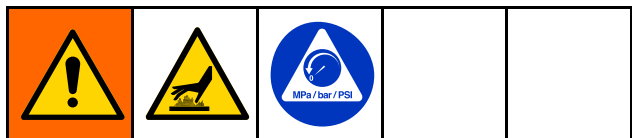

**NOTE:** Diaphragm kits are available in a range of materials and styles. See Parts section.

1. Follow the [Pressure Relief Procedure, page 9](#).
2. Remove the manifolds and disassemble the check valves as explained in [Check Valve Repair, page 12](#).
3. Remove the clamps (21) from the fluid covers (15), then pull the fluid covers off of the pump.
4. Once the fluid covers are removed, the diaphragm on the side of the pump which was last pressurized with air will be separated from the center section/air cover. This allows you to grip the diaphragms.
5. Diaphragms are assembled hand tight. To loosen, grip both diaphragms securely around the outer edge and rotate counterclockwise. One diaphragm assembly will come free and the other will remain attached to the shaft. Remove the freed diaphragm (10) and air side plate (9).

6. Pull the opposite diaphragm assembly and shaft (24) out of the center housing (101). Hold the shaft flats with a 7/8 in. open end wrench and remove the diaphragm and air side plate from the shaft.
7. Inspect the diaphragm shaft (24) for wear or scratches. If it is damaged, inspect the bearings (107) in place. If the bearings are damaged, refer to [Center Section Repair, page 18](#).
8. Reach into the center housing (101) with an o-ring pick and hook the u-cups (106), then pull them out of the housing. This can be done with the bearings (107) in place.
9. Clean all parts and inspect for wear or damage. Replace parts as needed.

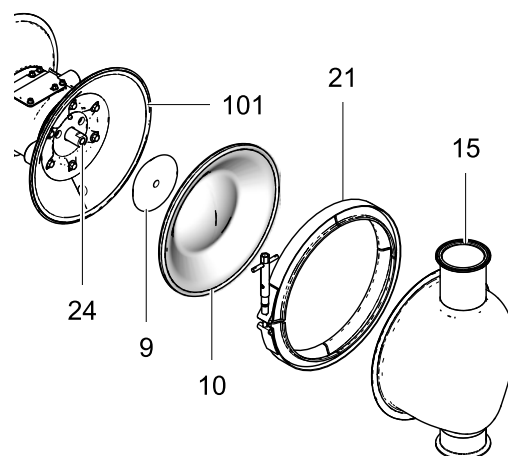

ti35833a

## Reassemble the Overmolded Diaphragms

### NOTICE

After reassembly, allow the thread locker to cure for 12 hours, or per manufacturer's instructions, prior to operating the pump. Damage to the pump will occur if the diaphragm shaft bolt loosens.

**TIP:** If you are also repairing or servicing the center section, follow [Center Section Repair, page 18](#), before replacing diaphragms.

1. Lubricate and install the shaft u-cups (106) so the lips face **out** of the housing (101).
2. Assemble plate (9) onto diaphragm (10), with screw (14). Rounded side of plate (9) should face diaphragm. Make sure the side marked AIR SIDE faces the center housing.

**NOTE:** Thread locker must be applied to screw (14) as shown for all diaphragm assemblies.

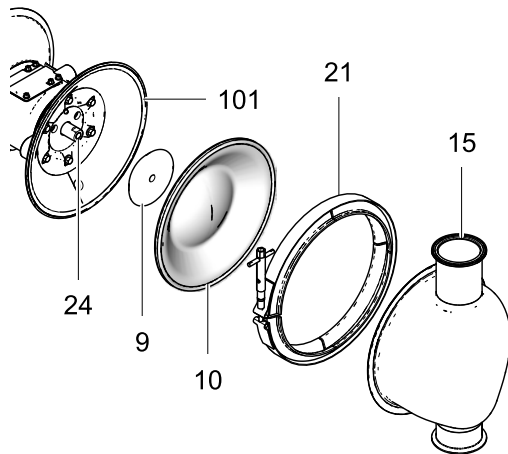

t135833a

1. Apply a high-strength thread locker to attach the screw to the diaphragm plate, if needed.
2. Apply a medium-strength thread locker to the shaft side of the screw.

3. Screw assembled diaphragm assembly into shaft (24) and hand tighten.
4. Grease the length of the diaphragm shaft (24), and slide it through the housing (101).
5. Assemble the other diaphragm assembly to the shaft as explained in step 2.
6. Grip both diaphragms securely around their outer edges and rotate clockwise until bottomed on the shaft.

**NOTE:** Apply waterproof, sanitary lubricant to the clamp (21) and clamping surface of the cover (15) to ease assembly.

**NOTE:** Fluid cover movement may be needed when installing manifolds. Install cover clamps loose enough to allow cover movement for spacing and alignment of manifolds.

**NOTE:** Use a food grade anti-seize lubricant on the clamp threads to aid assembly.

7. Align the fluid covers (15) and the center housing. Secure the covers with the clamps (21) and hand tighten. If, after installing the first fluid cover, the opposing diaphragm protrudes away from the center housing, leaving a gap between the center housing and the second fluid cover, do not try to force the diaphragm into position. Instead, complete the following procedures in [Using Diaphragm Install Tool, page 17](#), to position the diaphragm and allow fluid cover installation.
8. Reassemble the ball check valves and manifolds as explained in [Check Valve Repair, page 12](#).

## Using Diaphragm Install Tool

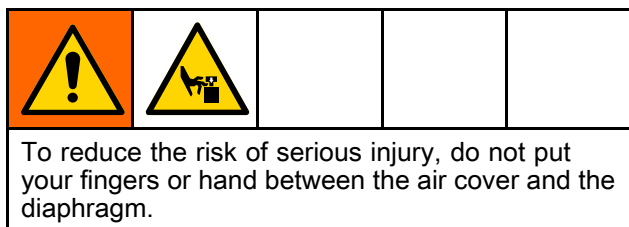

If repairs involve removal of fluid covers, these steps will ease installation of fluid covers. The diaphragm install tool kit 16G876 is available separately.

1. Remove the air valve nuts (105), air valve (104) and gasket (103).
2. Lubricate the inner surface of both cover clamps with waterproof sanitary lubricant. Install the cover and clamp on the side of the pump with the diaphragm against the air cover. Leave the clamp slightly tightened but loose enough to allow minor cover rotation to allow for alignment with the inlet and outlet manifolds.
3. Install the supplied diaphragm install tool so that the arrow (A) points toward the side of the pump with the diaphragm against the air cover. Install the air valve (104) and nuts (105). Snug the air valve cover nuts.
4. Supply the pump with low pressure air, just enough to move the diaphragm. Use about 10 psi (0.07 MPa, 0.7 bar) for standard diaphragms or 20 psi (0.14 MPa, 1.4 bar) for overmolded diaphragms. Shop air may be used. The diaphragm will shift so the second fluid cover will seat properly. Keep air pressure on until the second fluid cover is installed.
5. Install the remaining fluid cover and clamp.
6. Remove air supply from the pump.
7. Follow the [Pressure Relief Procedure, page 9](#) . Disconnect the air valve and the tool.
8. Remove the air valve and the tool.
9. If no other air valve repairs are needed, install the gasket (103), air valve (104) and nuts (105). Use a crisscross pattern and torque nuts to 45–55 in-lb (5-6.2 N•m)

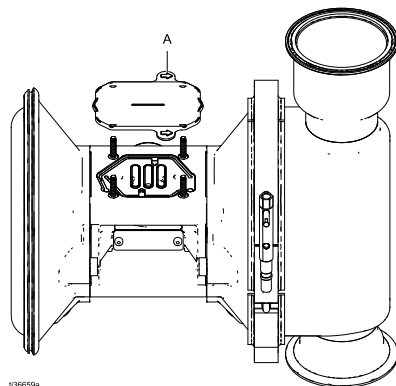

## Center Section Repair

### Tools Required:

- Torque wrench
- 10 mm socket wrench
- 9/16 in. socket wrench
- Bearing puller
- O-ring pick
- Press, or block and mallet

### Disassemble the Center Section



1. Follow the [Pressure Relief Procedure, page 9](#) . Disconnect all fluid and air lines.
2. Follow either the [Disassemble the Standard Diaphragms, page 13](#) or [Disassemble the Overmolded Diaphragms, page 15](#), as appropriate.
3. Remove pilot valves (111).
4. Use a 3/8 hex wrench to remove two bolts (113), then remove one air cover (110) and alignment pins (108). Repeat for the other air cover.
5. Inspect the diaphragm shaft (24) for wear or scratches. If it is damaged, inspect the bearings (107) in place. If they are damaged, use a bearing puller to remove them.

**NOTE:** Do not remove undamaged bearings.

### Reassemble the Center Section

**NOTE:** Use lithium-based grease whenever instructed to grease. Order Graco PN 111920.

1. Clean all parts and inspect for damage. Replace parts as needed.
2. Grease and install the diaphragm shaft u-cups (106) so the lips face **out** of the housing and toward the bearing they are behind.
3. If replacing the shaft bearings, insert the new bearings (107) into the center housing. Use a press or a block and rubber mallet to press-fit the bearing so it is flush with the surface of the center housing.
4. Install the air covers:
  - a. Put one air cover on the bench. Install the alignment pins (108) and a new gasket (109).
  - b. Carefully place the center section on the air cover.
  - c. Install the second set of alignment pins (108) and gasket (109) in the center section. Lower the second air cover onto the center housing.
  - d. Apply medium-strength (blue) thread locker on the bolts (113). Install two bolts and torque to 30-40ft-lb (41-54 N•m). Turn the pump over on the bench and install and torque the other two bolts.
5. Grease and install pilot valves (111). Torque to 20-25 in-lb (2.3-2.8 N•m). Do not over-torque.

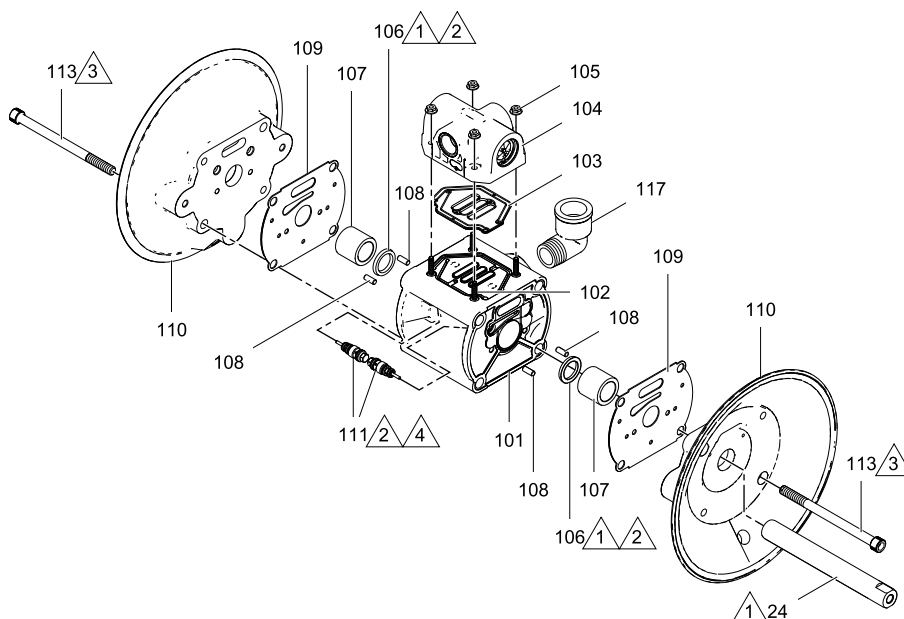

- △ 1 Apply lithium-based grease.
- △ 2 Lips must face out of housing.
- △ 3 Torque to 30–40 ft-lb (41–54 N•m).
- △ 4 Torque to 20-25 in-lb (2.3-2.8 N•m).

036131b

## Leak Detectors

Leak detectors are sensors that are mounted in the air covers of the pump to monitor for fluid leakage caused by a diaphragm rupture. Leak detectors are provided with 3-A pumps and can be ordered separately for other pumps. For leak sensor electrical and configuration information, refer to the leak detection system manual (3A6976).

Available leak detection kits:

Kit	Description
17Z666	Kit, Standard, non-ATEX, 2 sensors, 2 bushings; provided with 3-A pumps
17Z667	Kit, ATEX, 2 sensors, 2 bushings, 2 o-rings
25P303	Kit, Leak detection control box; not approved for use in an ATEX environment
25P305	Kit, Leak detection control box mounting bracket and mounting hardware

### Leak Detector Testing

1. Obtain a small container of the material being pumped.
2. Perform the [Pressure Relief Procedure, page 9](#).
3. Unscrew and remove both leak detector bushings (with installed leak detectors) from the air side diaphragm covers.
4. For each leak detector, dip the bushing, with the leak detector still installed, into the material container in an orientation that mimics how it would be oriented in the air side diaphragm cover. Observe whether the leak detector senses the presence of the material.
5. If the leak detector successfully detected the material, clean the bushing and leak detector and re-install the leak detector and bushing as described in step 6. Ensure that both leak detectors successfully detected the material before installing.

**NOTE:** If the leak detector fails to sense the material, troubleshoot the leak detector to see if the leak sensor has failed or the leak detector is unable to detect the material.

6. To install leak detector to the pump:
  - a. If the leak detector needs to be installed in the bushing, simply screw the leak detector in just past finger tight.
 

**NOTE:** If using the ATEX leak detector, install the o-ring onto the leak detector before installation into the bushing.
  - b. If the bushing is not installed in the air side diaphragm cover, screw the bushing into the air side diaphragm cover.
  - c. If the leak detector was disconnected from the monitoring device, re-attach the leak detector wires to the monitoring device.
7. Repeat steps 3–6 for the other leak detector.

### Leak Detector Removal

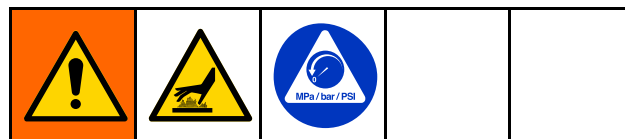

1. Follow the [Pressure Relief Procedure, page 9](#).
2. Note the connection locations of the leak detector wires within the monitoring device, then disconnect the leak detector wires.
3. Remove the leak detector from the bushing in the air side diaphragm cover.
4. If desired, repeat to remove the other leak detector from the other air side diaphragm cover.

### Leak Detector Reassembly

1. If the leak detector needs to be installed in the bushing, simply screw the leak detector in just past finger tight.
 

**NOTE:** If using the ATEX leak detector, install the o-ring onto the leak detector before installation into the bushing.
2. If the bushing is not installed in the air side diaphragm cover, screw the bushing into the air side diaphragm cover.
3. If removed, re-attach the leak detector wiring to the monitoring device.

# Parts

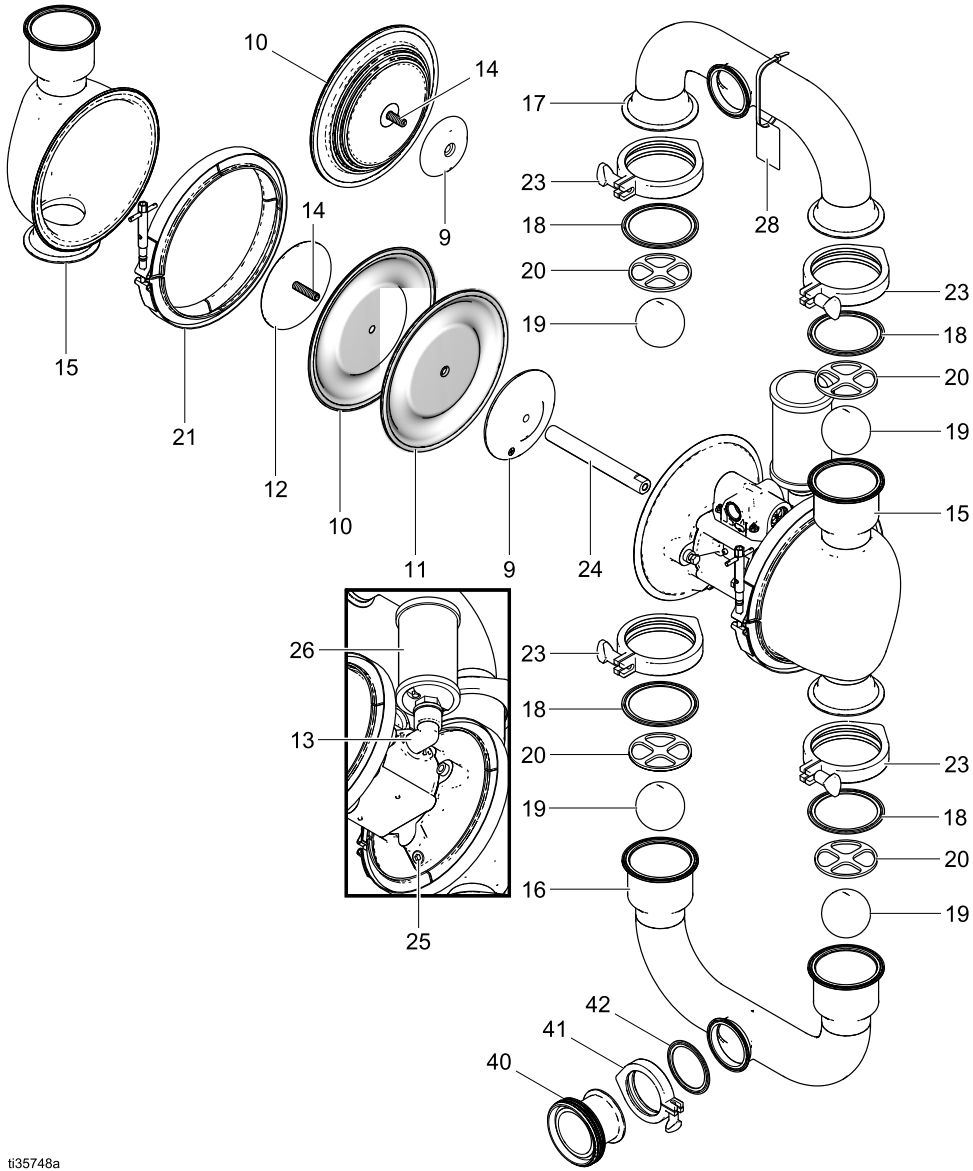

ti35748a

SP3B.xxxx model shown

## Parts/Kits Quick Reference

Use this table as a quick reference for parts/kits. Go to the pages indicated in the table for a full description of kit contents.

Ref.	Part	Kit	Description	Qty.
1	-----	-----	MODULE, drive; <i>See page 22</i>	1
2	-----	25P490	FRAME; <i>See page 26</i>	1
3	15D008	25P490	BOLT, frame attachment	4
4	-----	25P490	SPACER, frame attachment	4
9	189298	-----	PLATE, air side BN, EO, FK, SP, PS	2
10	-----	-----	DIAPHRAGM, kit; <i>See page 25</i>	1 kit
11	-----	-----	DIAPHRAGM, backup, <i>included with Ref. 10 where needed</i>	2
12	15D018	-----	PLATE, fluid side, BN, FK, PS, SP only	2
14	15D021	-----	SCREW, diaphragm	2
15	----- -----	25P017 25P043	COVER, fluid HS, 3-A PH	2
16	----- -----	25P026 25P056	MANIFOLD, inlet; HS, 3-A PH	1
17	----- -----	25P027 25P057	MANIFOLD, outlet; HS, 3-A PH	1
18	25P064 26A893 25R603 26A916	----- ----- ----- -----	GASKET, pkg of 4 EPDM (EP) FKM (FK) Buna-N (BN) PTFE/EPDM bonded (PT-EP), <i>offered only as replacement</i>	1

Ref.	Part	Kit	Description	Qty.
19	----- ----- ----- ----- ----- -----	25T447 25P566 25P568 25P569 25P570 25P571	BALLS, check valve; pkg of 4 EPDM PTFE Santoprene Buna-N Fluoroelastomer Polychloroprene	1
20	-----	25P101	STOP, ball; pkg of 4	1
21	-----	25P107	CLAMP, fluid cover <i>kit is one clamp</i>	2
22	-----	25P107	HANDLE, tee	2
23	510490	-----	CLAMP, sanitary	4
24	17Y239	-----	SHAFT, diaphragm	1
25	103778	-----	PLUG, leak detector holes	2
26	-----	25P572	MUFFLER	1
27	-----	17Z666	DETECTOR, leak, 3-A only; pkg of 2	1
28▲	25P457	-----	LABEL, safety	1
40	----- -----	25P111 25P121	ADAPTER, DIN HS, 3-A PH	2
41	15D475	25P111 25P121	CLAMP, DIN adapter	2
42	25P203	25P111 25P121	GASKET, DIN adapter, EPDM, pkg of 2	1

----- *Not available.*

▲ Replacement safety labels, signs, tags, and cards are available at no cost.

## Center Section

Sample Configuration Number

Pump Model	Wetted Section Material	Drive	Center Section and Air Valve Material	Manifolds	Seats	Checks	Diaphragms	Seals	Certification
3250	HS	P	<b>P01A</b>	SSA	SS	PT	SP	EP	21

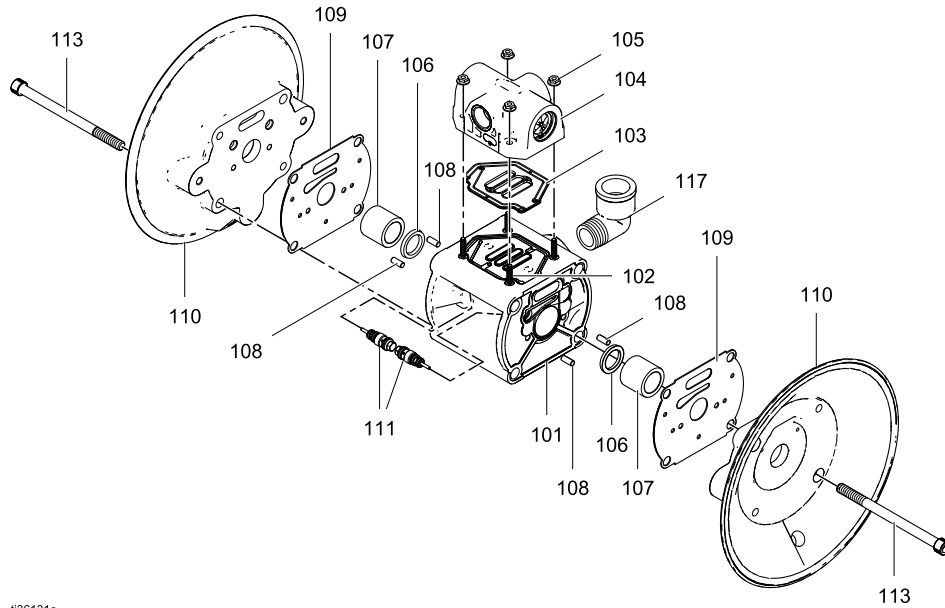

1136131a

Ref	Part	Kit	Description	Qty
101	---	25P497	HOUSING, center, assembly	1
102	---	25P497	STUD	4
103	15V891	24K859 24K860 25P488	GASKET, cover, air valve	1
104	---	25P488	AIR VALVE ASSY	1
105	15U698	25P488	NUT	4
106	113265	25P497 24K854	U-CUP	2
107	15V904	25P497 24K854	BEARING, shaft	2
108	---	25P491 25P492	PIN, alignment	4

Ref	Part	Kit	Description	Qty
109			GASKET, air cover	2
	---	25P491 25P492 25P495	use with PS diaphragms	
	---	25P491 25P492 25P494	use with all diaphragms except PS diaphragms	
110			COVER, air	2
	---	25P491	3A, HS	
	---	25P492	PH	
111	247391	24A366	VALVE, pilot	2
113	124120	24K869	SCREW	4
117	16A942	---	FITTING, muffler	1

# Air Valve

Sample Configuration Number

Pump Model	Wetted Section Material	Drive	Center Section and Air Valve Material	Manifolds	Seats	Checks	Diaphragms	Seals	Certification
3250	HS	P	P01A	SSA	SS	PT	SP	EP	21

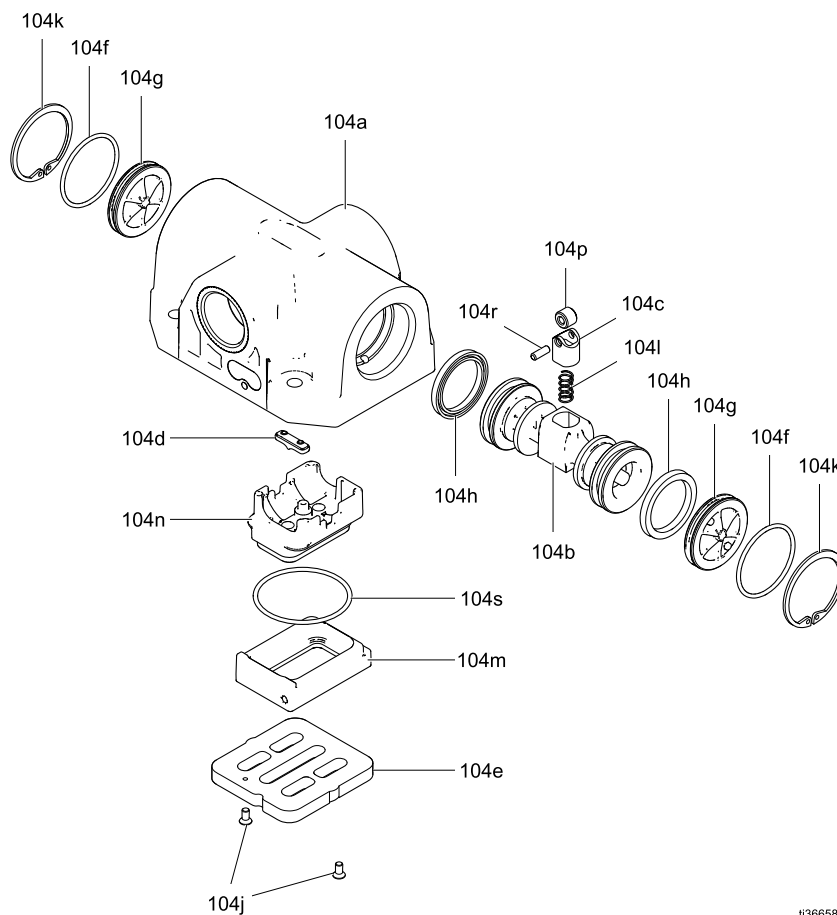

t136658a

Ref.	Part	Kit	Description	Qty.
104a	----	----	HOUSING	1
104b	15M240	24K860	PISTON, air valve	1
104c	----	24K860	PISTON, detent	1
104d	15K909	24K860	CAM, detent	1
104e	----	24K860	PLATE	1
104f	----	24K859 24K860 24C053	O-RING	2
104g	----	24C053	CAP	2
104h	----	24K859 24K860	SEAL, u-cup	2

Ref.	Part	Kit	Description	Qty.
104j	----	24K859 24K860	SCREW, thd forming	2
104k	----	24C053	RING, snap	2
104l	15M272	24K860	SPRING, detent	1
104m	----	24K860	BASE	1
104n	----	24K860	CUP, air	1
104p	15K911	24K860	ROLLER, detent	1
104r	15K912	24K860	PIN, detent	1
104s	107185	24K860	O-RING	1

## Fluid Covers and Manifolds

Sample Configuration Number

Pump Model	Wetted Section Material	Drive	Center Section and Air Valve Material	Manifolds	Seats	Checks	Diaphragms	Seals	Certification
3250	HS	P	P01A	SSA	SS	PT	SP	EP	21

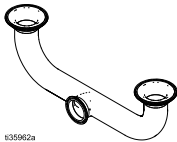
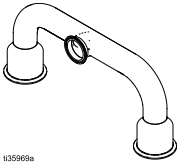
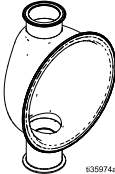
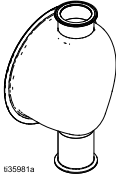
Pump PN prefix	Manifold	Wetted Section	Manifold*		Fluid Cover	
			Inlet	Outlet	Left (Ref 15)	Right (Ref 15)
SP3B	SSA, SSB	HS, 3-A PH	 <small>t35962a</small> 25P026 25P056	 <small>t35969a</small> 25P027 25P057	 <small>t35974a</small> 25P017 25P043	 <small>t35981a</small> 25P017 25P043

\* Requires DIN adapter fitting, DIN adapter gasket, and clamp on each manifold for manifold type SSB

# Diaphragms

Sample Configuration Number

Pump Model	Wetted Section Material	Drive	Center Section and Air Valve Material	Manifolds	Seats	Checks	Diaphragms	Seals	Certification
3250	HS	P	P01A	SSA	SS	PT	SP	EP	21

Bolt-Through Diaphragm Kits	
BN	253223
FK	25P268
PS	25P266
SP	25P265

Overmolded Diaphragm Kit	
EO	25P270

Kits include:

- 2 overmolded diaphragms (10) with set screws (14)

Kits include:

- 2 diaphragms (10)
- 2 diaphragm backers (11), if applicable
- 1 packet anaerobic adhesive
- 2 o-rings

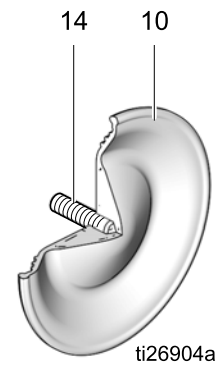
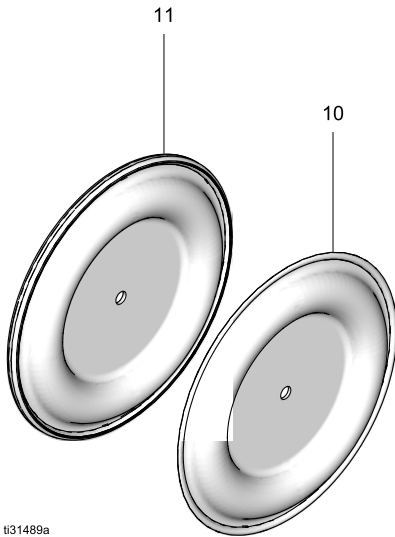

## Parts

Kit descriptions appear in the following order: *Pump model, seat material, ball material, diaphragm material, gasket material.* For example, *3250HS-PH --,CR,EO,EP.* Refer to [Configuration Number Matrix, page 5](#), to define components.

### Fluid Section Repair Kits

Kit	Description
25R734	3250HS-PH --,BN,BN,BN
25R735	3250HS-PH --,CR,EO,EP
25R736	3250HS-PH --,CR,FK,FK
25R737	3250HS-PH --,CR,SP,EP
25R738	3250HS-PH --,EP,EO,EP
25R739	3250HS-PH --,EP,SP,EP
25R740	3250HS-PH --,FK,FK,FK
25R741	3250HS-PH --,PT,EO,EP
25R742	3250HS-PH --,PT,PS,EP
25R743	3250HS-PH --,PT,SP,EP
25R744	3250HS-PH --,SP,SP,EP

Kits include:

- 4 balls (19)
- 2 diaphragms (10)
- 2 diaphragm backers (11), if applicable
- 4 gaskets
- 1 packet anaerobic sealant
- 2 o-rings

# Frames

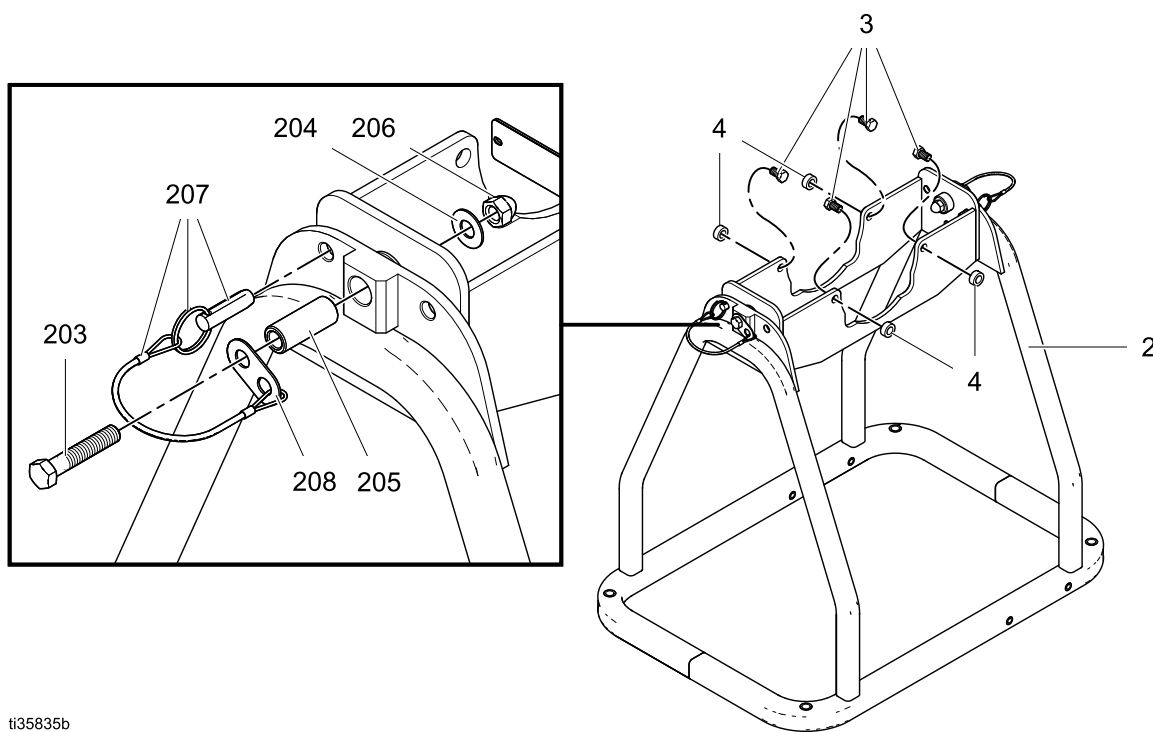

ti35835b

25P490 shown; *includes items 2, 3, & 4*

Ref.	Part	Kit	Description	Qty.
203	---	24N798	SCREW, 3/8-16 unc	2
204	111743	24N798	WASHER, flat	2
205	---	24N798	BUSHING	2
206	---	24N798	NUT, acorn	2
207	---	24N799	PIN, quick release	2
208	---	24N799	RETAINER	2

# Technical Specifications

<b>SaniForce 3250 Air-Operated Double Diaphragm Pump</b>		
	<b>US</b>	<b>Metric</b>
Maximum fluid working pressure	100 psi	0.7 MPa, 6.9 bar
Air pressure operating range	20 to 100 psi	0.14 to 0.7 MPa, 1.4 to 6.9 bar
Air inlet size	3/4 in. npt(f)	
Maximum suction lift (reduced if balls don't seat well due to damaged balls or seats, lightweight balls, or extreme speed of cycling)	Wet: 30 ft Dry: 10 ft	Wet: 9.1 m Dry: 3.0 m
Maximum size pumpable solids	3/4 in.	19 mm
Minimum ambient air temperature for operation and storage. <b>NOTE:</b> Exposure to extreme low temperatures may result in damage to plastic parts.	32° F	0° C
Fluid displacement per cycle	1.2 gallons	4.54 liters
Maximum free-flow delivery	230 gpm	870 lpm
Maximum pump speed	190 cpm	
<b>Weight</b>		
All Models	124 lbs	56.2 kg
<b>Fluid Inlet and Outlet Size</b>		
Stainless Steel	3 in sanitary flange or 80 mm DIN 11851, male thread	
<b>Noise Data</b>		
Sound Power (measured per ISO-9614-2)		
at 125 psi fluid pressure and full flow	106.1 dBa	
at 50 psi fluid pressure and 50 cpm	99.1 dBa	
Sound Pressure [tested 3.28 ft (1 m) from equipment]		
at 125 psi fluid pressure and full flow	98.2 dBa	
at 50 psi fluid pressure and 50 cpm	91.5 dBa	
<b>Wetted Parts</b>		
Wetted parts include material(s) chosen for seat, ball, and diaphragm options, 316 stainless steel		
<b>Non-wetted parts</b>		
Non-wetted external parts include nickel-plated aluminum, Nylon, 300-series stainless steel, 17-4 stainless steel, VHB acrylic		

## Fluid Temperature Range

### NOTICE

Temperature limits are based on mechanical stress only. Certain chemicals will further limit the fluid temperature range. Stay within the temperature range of the most-restricted wetted component. Operating at a fluid temperature that is too high or too low for the components of your pump may cause equipment damage.

Diaphragm/Ball/Seat Material	Stainless Steel Pump Fluid Temperature Range	
	Fahrenheit	Celsius
Buna-N (BN)	10° to 180°F	-12° to 82°C
FKM Fluoroelastomer (FK)	-40° to 275°F	-40° to 135°C
Polychloroprene check balls (CR)	14° to 176°F	-10° to 80°C
PTFE check balls (PT)	-40° to 220°F	-40° to 104°C
EPDM overmolded diaphragm (EO)	-40° to 250°F	-40° to 121°C
PTFE overmolded diaphragm (PO)	-40° to 180°F	-40° to 82°C
2-piece PTFE/Santoprene diaphragm (PS)	-40° to 180°F	-40° to 82°C
Santoprene (SP)	-40° to 180°F	-40° to 82°C

## California Proposition 65

### CALIFORNIA RESIDENTS

 **WARNING:** Cancer and reproductive harm — [www.P65warnings.ca.gov](http://www.P65warnings.ca.gov).

# Graco Standard Warranty

Graco warrants all equipment referenced in this document which is manufactured by Graco and bearing its name to be free from defects in material and workmanship on the date of sale to the original purchaser for use. With the exception of any special, extended, or limited warranty published by Graco, Graco will, for a period of twelve months from the date of sale, repair or replace any part of the equipment determined by Graco to be defective. This warranty applies only when the equipment is installed, operated and maintained in accordance with Graco's written recommendations.

This warranty does not cover, and Graco shall not be liable for general wear and tear, or any malfunction, damage or wear caused by faulty installation, misapplication, abrasion, corrosion, inadequate or improper maintenance, negligence, accident, tampering, or substitution of non-Graco component parts. Nor shall Graco be liable for malfunction, damage or wear caused by the incompatibility of Graco equipment with structures, accessories, equipment or materials not supplied by Graco, or the improper design, manufacture, installation, operation or maintenance of structures, accessories, equipment or materials not supplied by Graco.

This warranty is conditioned upon the prepaid return of the equipment claimed to be defective to an authorized Graco distributor for verification of the claimed defect. If the claimed defect is verified, Graco will repair or replace free of charge any defective parts. The equipment will be returned to the original purchaser transportation prepaid. If inspection of the equipment does not disclose any defect in material or workmanship, repairs will be made at a reasonable charge, which charges may include the costs of parts, labor, and transportation.

**THIS WARRANTY IS EXCLUSIVE, AND IS IN LIEU OF ANY OTHER WARRANTIES, EXPRESS OR IMPLIED, INCLUDING BUT NOT LIMITED TO WARRANTY OF MERCHANTABILITY OR WARRANTY OF FITNESS FOR A PARTICULAR PURPOSE.**

Graco's sole obligation and buyer's sole remedy for any breach of warranty shall be as set forth above. The buyer agrees that no other remedy (including, but not limited to, incidental or consequential damages for lost profits, lost sales, injury to person or property, or any other incidental or consequential loss) shall be available. Any action for breach of warranty must be brought within two (2) years of the date of sale.

**GRACO MAKES NO WARRANTY, AND DISCLAIMS ALL IMPLIED WARRANTIES OF MERCHANTABILITY AND FITNESS FOR A PARTICULAR PURPOSE, IN CONNECTION WITH ACCESSORIES, EQUIPMENT, MATERIALS OR COMPONENTS SOLD BUT NOT MANUFACTURED BY GRACO.** These items sold, but not manufactured by Graco (such as electric motors, switches, hose, etc.), are subject to the warranty, if any, of their manufacturer. Graco will provide purchaser with reasonable assistance in making any claim for breach of these warranties.

In no event will Graco be liable for indirect, incidental, special or consequential damages resulting from Graco supplying equipment hereunder, or the furnishing, performance, or use of any products or other goods sold hereto, whether due to a breach of contract, breach of warranty, the negligence of Graco, or otherwise.

## FOR GRACO CANADA CUSTOMERS

The Parties acknowledge that they have required that the present document, as well as all documents, notices and legal proceedings entered into, given or instituted pursuant hereto or relating directly or indirectly hereto, be drawn up in English. Les parties reconnaissent avoir convenu que la rédaction du présente document sera en Anglais, ainsi que tous documents, avis et procédures judiciaires exécutés, donnés ou intentés, à la suite de ou en rapport, directement ou indirectement, avec les procédures concernées.

## Graco Information

For the latest information about Graco products, visit [www.graco.com](http://www.graco.com).  
For patent information, see [www.graco.com/patents](http://www.graco.com/patents).

**To place an order**, contact your Graco Distributor or call to identify the nearest distributor.

**Phone:** 612-623-6921 **or Toll Free:** 1-800-328-0211 **Fax:** 612-378-3505

All written and visual data contained in this document reflects the latest product information available at the time of publication.

Graco reserves the right to make changes at any time without notice.  
Original Instructions. This manual contains English. MM 3A6783

**Graco Headquarters:** Minneapolis  
**International Offices:** Belgium, China, Japan, Korea

**GRACO INC. AND SUBSIDIARIES • P.O. BOX 1441 • MINNEAPOLIS MN 55440-1441 • USA**  
**Copyright 2019, Graco Inc. All Graco manufacturing locations are registered to ISO 9001.**

[www.graco.com](http://www.graco.com)  
Revision D, January 2021