

# Overspray Masking Liquid System

308069P

EN

For airspray application of fluids. For professional use only.

## System

### Model 224826

with Stainless Steel Pump\*

## Pump

### Model 224825, Series A

Stainless Steel\*

*2700 psi (18.6 MPa, 186 bar) Maximum Working Pressure*

*80-90 psi (0.55-0.62 MPa, 5.5-6.2 bar) recommended regulated air inlet pressure*

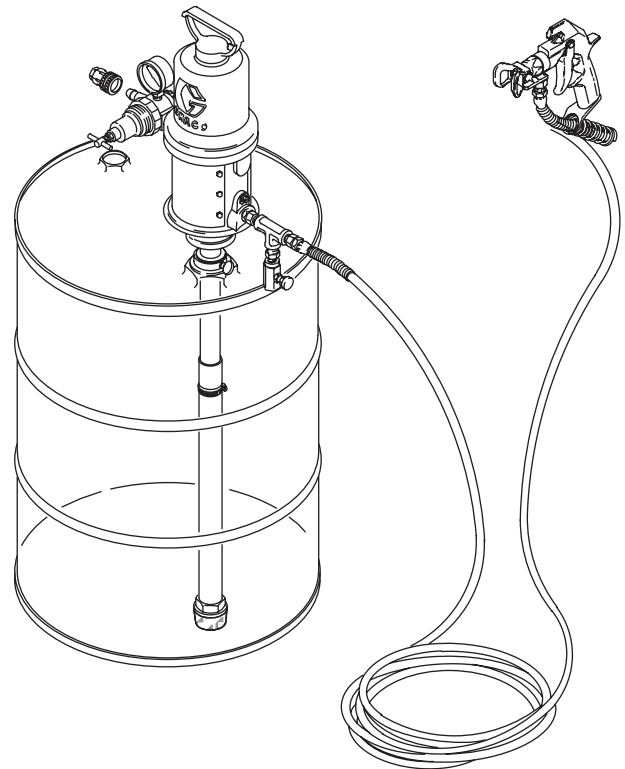


## Important Safety Instructions

Read all warnings and instructions in this manual. Save these instructions.

### NOTICE

This pump is factory tested in oil. To avoid contaminating the masking liquid or the surface being painted, flush the pump before immersing it in the masking liquid. Use water only to flush. Paint solvents will damage the seals. Follow the set-up procedure carefully, and pay special attention to the Flushing procedure on page 6.






# Contents

<b>Warnings</b> .....	<b>3</b>	<b>Maintenance</b> .....	<b>12</b>
<b>Installation</b> .....	<b>5</b>	Weekly Flushing .....	12
Grounding .....	5	Flushing Before Storing .....	12
Prepare for Installation .....	5	Pump Packing Nut Adjustment .....	13
Setup for Initial Flushing .....	6	<b>Troubleshooting</b> .....	<b>14</b>
Initial Flushing .....	6	<b>Service</b> .....	<b>16</b>
Pump Installation .....	7	Before Starting .....	16
<b>Operation</b> .....	<b>8</b>	Air Motor and Throat Disassembly .....	16
Pressure Relief Procedure .....	8	Air Motor and Throat Reassembly .....	17
Prime the System .....	8	Displacement Pump Disassembly .....	18
Selecting a Tip .....	9	Displacement Pump Reassembly .....	19
Installing the Spray Tip .....	9	<b>Parts</b> .....	<b>20</b>
Changing Spray Tips .....	10	<b>Technical Data</b> .....	<b>23</b>
Clearing a Clogged Spray Tip .....	10	<b>Dimensions</b> .....	<b>23</b>
Adjusting the Spray Pattern and Spraying Pressure	10	<b>Graco Standard Warranty</b> .....	<b>.24</b>
10			
Practice Spraying .....	11		

# Warnings

The following warnings are for the setup, use, grounding, maintenance, and repair of this equipment. The exclamation point symbol alerts you to a general warning and the hazard symbols refer to procedure-specific risks. When these symbols appear in the body of this manual or on warning labels, refer back to these Warnings. Product-specific hazard symbols and warnings not covered in this section may appear throughout the body of this manual where applicable.

 <h2 style="margin: 0;">WARNING</h2>	
	<p><b>FIRE AND EXPLOSION HAZARD</b></p> <p>When flammable fluids are present in the work area, such as gasoline and windshield wiper fluid, be aware that flammable fumes can ignite or explode. To help prevent fire and explosion:</p> <ul style="list-style-type: none"> <li>• Use equipment only in well ventilated area.</li> <li>• Eliminate all ignition sources, such as cigarettes and portable electric lamps.</li> <li>• Keep work area free of debris, including rags and spilled or open containers of solvent and gasoline.</li> <li>• Do not plug or unplug power cords or turn lights on or off when flammable fumes are present.</li> <li>• Ground all equipment in the work area.</li> <li>• Use only grounded hoses.</li> <li>• <b>Stop operation immediately</b> if static sparking occurs or you feel a shock. Do not use equipment until you identify and correct the problem.</li> <li>• Keep a working fire extinguisher in the work area.</li> </ul>
	<p><b>SKIN INJECTION HAZARD</b></p> <p>High-pressure fluid from gun, hose leaks, or ruptured components will pierce skin. This may look like just a cut, but it is a serious injury that can result in amputation. <b>Get immediate surgical treatment.</b></p> <ul style="list-style-type: none"> <li>• Do not spray without tip guard and trigger guard installed.</li> <li>• Engage trigger lock when not spraying.</li> <li>• Do not point gun at anyone or at any part of the body.</li> <li>• Do not put your hand over the spray tip.</li> <li>• Do not stop or deflect leaks with your hand, body, glove, or rag.</li> <li>• Follow the <b>Pressure Relief Procedure</b> when you stop spraying and before cleaning, checking, or servicing equipment.</li> <li>• Tighten all fluid connections before operating the equipment.</li> <li>• Check hoses and couplings daily. Replace worn or damaged parts immediately.</li> </ul>



# WARNING



## EQUIPMENT MISUSE HAZARD

Misuse can cause death or serious injury.

- Do not operate the unit when fatigued or under the influence of drugs or alcohol.
- Do not exceed the maximum working pressure or temperature rating of the lowest rated system component. See **Technical Data** in all equipment manuals.
- Use fluids and solvents that are compatible with equipment wetted parts. See Technical Data in all equipment manuals. Read fluid and solvent manufacturer's warnings. For complete information about your material, request MSDS from distributor or retailer.
- Turn off all equipment and follow the **Pressure Relief Procedure** when equipment is not in use.
- Check equipment daily. Repair or replace worn or damaged parts immediately with genuine manufacturer's replacement parts only.
- Do not alter or modify equipment. Alterations or modifications may void agency approvals and create safety hazards.
- Make sure all equipment is rated and approved for the environment in which you are using it.
- Use equipment only for its intended purpose. Call your distributor for information.
- Route hoses and cables away from traffic areas, sharp edges, moving parts, and hot surfaces.
- Do not kink or over bend hoses or use hoses to pull equipment.
- Keep children and animals away from work area.
- Comply with all applicable safety regulations.



## MOVING PARTS HAZARD

Moving parts can pinch, cut or amputate fingers and other body parts.

- Keep clear of moving parts.
- Do not operate equipment with protective guards or covers removed.
- Pressurized equipment can start without warning. Before checking, moving, or servicing equipment, follow the **Pressure Relief Procedure** and disconnect all power sources.



## TOXIC FLUID OR FUMES HAZARD

Toxic fluids or fumes can cause serious injury or death if splashed in the eyes or on skin, inhaled, or swallowed.

- Read MSDSs to know the specific hazards of the fluids you are using.
- Store hazardous fluid in approved containers, and dispose of it according to applicable guidelines.



## PERSONAL PROTECTIVE EQUIPMENT

Wear appropriate protective equipment when in the work area to help prevent serious injury, including eye injury, hearing loss, inhalation of toxic fumes, and burns. This protective equipment includes but is not limited to:

- Protective eyewear, and hearing protection.
- Respirators, protective clothing, and gloves as recommended by the fluid and solvent manufacturer

# Installation

Learn how to use the gun's trigger safety latch before operating the system.

The high pressure, airless spray gun supplied with this system is equipped with a trigger safety latch. When set, this latch prevents the gun from being triggered accidentally. Read more about gun safety in the warning section, Skin Injection Hazard.

Set the trigger safety latch whenever you stop spraying, even for only a minute, or if changing a tip.

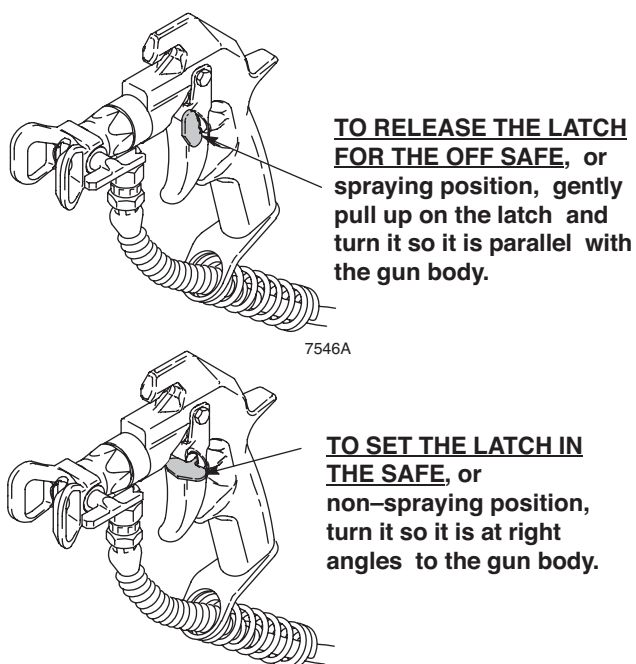


FIG. 1

## Grounding



The equipment must be grounded to reduce the risk of static sparking and electric shock. Electric or static sparking can cause fumes to ignite or explode. Improper grounding can cause electric shock. Grounding provides an escape wire for the electric current.

**Pump:** use ground wire and clamp (FIG. 2). Remove the ground screw (Z) and insert through the eye of ring terminal at end of ground wire (Y). Fasten the ground screw back onto the pump and tighten securely. Connect ground clamp to a true earth ground.

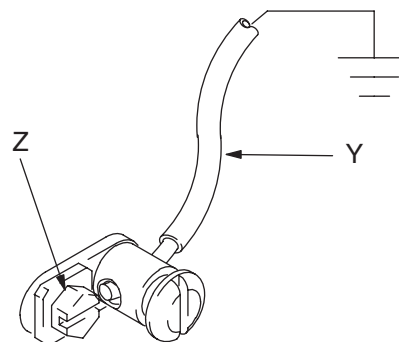


FIG. 2

**Air and fluid hoses:** use only electrically conductive hoses.

**Air compressor:** follow manufacturer's recommendations.

**Spray gun:** ground through connection to a properly grounded fluid hose and pump.

**Fluid supply container:** follow local code.

**Object being sprayed:** follow local code.

**Any pails used when flushing:** use only metal, grounded pails when flushing. Make firm metal-to-metal contact between a metal part of the spray gun and a pail. Use the lowest pressure possible.

## Prepare for Installation

Supply the following equipment to complete the installation of this system:

1. An adjustable wrench and a screwdriver.
2. A grounding wire and clamp for the air motor.
3. The compressed air supply with a hose that easily reaches the air regulator assembly.

- Two 5 gallon flushing containers, one with warm soapy water, and one with cool, clean water.

**NOTICE**

Do not use with pain solvents to flush, which will damage the pump seals.

## Setup for Initial Flushing

Refer to FIG. 3 for the following instructions.

- Screw the air regulator assembly into the air inlet of the motor.

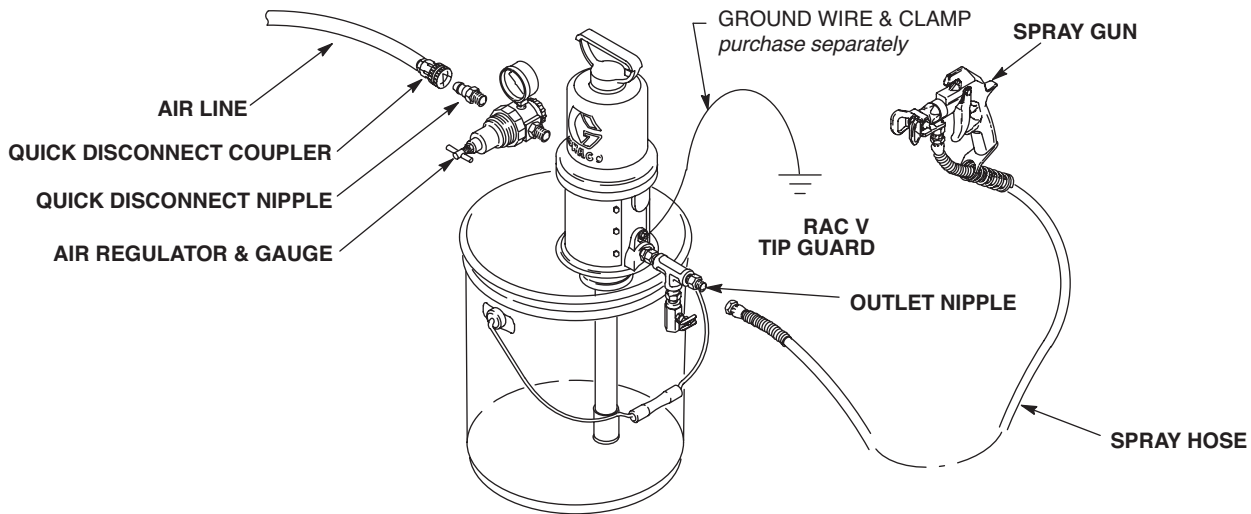


FIG. 3

## Initial Flushing

**NOTICE**

This pump is factory tested in oil. To avoid contaminating the masking liquid or the surface being painted, flush the pump before immersing it in the masking liquid.

- Mount the pump in a 5 gallon pail of warm, soapy water.
- Be sure there is no spray tip in the sun. See FIG. 7 if the tip needs to be removed.
- Set the trigger safety latch. (FIG. 1)
- Be sure the air regulator handle is turned to zero (fully left as you look at it).
- Connect the air line to the pump.
- Release the trigger safety latch.
- Aim the gun into the flushing pail and squeeze the gun trigger and hold it open.
- Slowly open the air regulator until the pump is running slowly and smoothly.
- Using very low pressure, direct the spray from the gun back into the flushing container. Circulate the soapy water in this way for several minutes. Then release the trigger, set the trigger safety latch, and disconnect the air line to the pump.
- Switch the pump to the clean container of water. Connect the air line, release the trigger safety latch, and repeat Step 9, above.

11. Raise the pump out of the pail. Trigger the gun to force the water from the system. DO NOT run the pump dry for more than 10 seconds to avoid damaging the pump packings.

## Pump Installation

**NOTE:** Be sure the system has been thoroughly flushed.

1. Loosen the hose clamp on the suction hose. Slide the suction hose as far as possible onto the pump intake valve.
2. **Slide the clamp up and tighten its screw snugly.**  
A loose clamp prevent the pump from getting adequate fluid supply, which results in low fluid flow and/or spitting air from the gun.
3. Remove the bung cover from the drum and open the vent hole.
4. Loosen the thumbscrew on the bung adapter.
5. Slide the suction hose and pump through the bung hole in the drum cover. Before the final positioning of the pump, screw the bung adapter firmly into the bung hole. Now position the pump as follows:
  - a. For 55 gallon drums: Slide the pump into the drum until you sense that the strainer is at the bottom of the drum. Tighten the thumbscrew snugly.
  - b. For 16 gallon drums: Slide the pump into the drum and allow the suction hose to curl around the side and rest on the bottom of the drum. Tighten the thumbscrew snugly.
  - c. For 5 gallon demo pails: Remove the suction hose and strainer. Install the accessory pail cover (Part No. 222058). Slide the pump into the pail until the intake valve is 1/2" off the bottom of the pail. Tighten the bung adapter thumbscrew snugly.

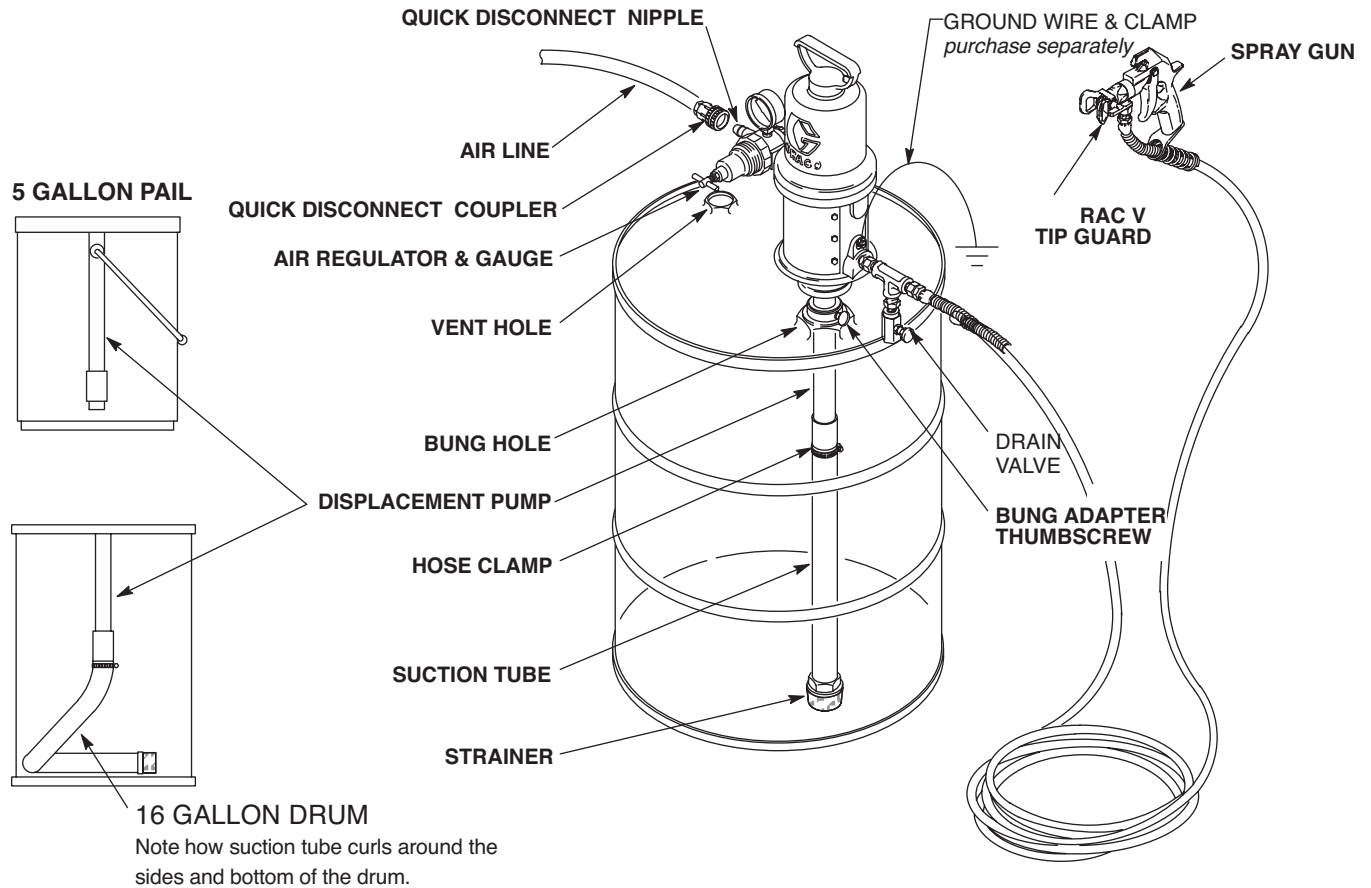


FIG. 4

# Operation

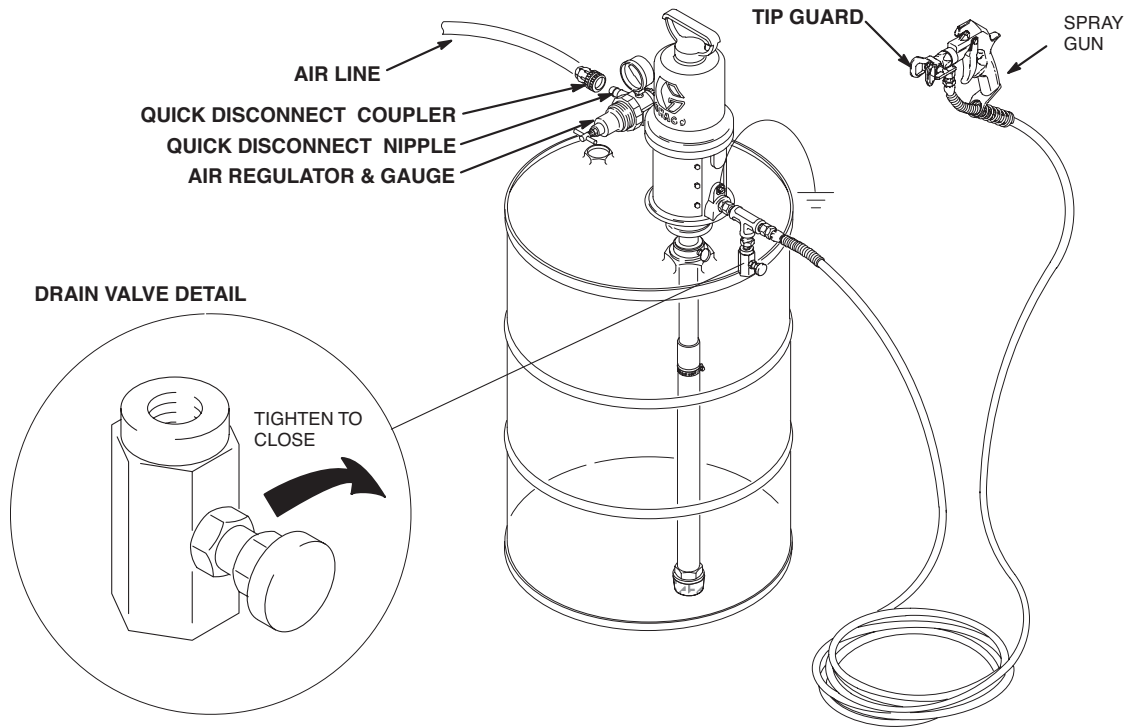


FIG. 5

## Pressure Relief Procedure



Follow the Pressure Relief Procedure whenever you see this symbol.



This equipment stays pressurized until pressure is manually relieved. To help prevent serious injury from pressurized fluid, such as skin injection, splashing fluid and moving parts, follow the Pressure Relief Procedure when you stop spraying and before cleaning, checking, or servicing the equipment.

1. Engage the gun's trigger safety latch.
2. Close the air regulator and disconnect the air supply hose.
3. Disengage the trigger safety latch. Hold a metal part of the gun firmly to the side of a grounded metal waste pail and trigger it to relieve the fluid pressure.
4. Engage the trigger safety latch.

5. Place a pail under the drain valve and open the drain valve to be sure all fluid pressure is relieved.

**NOTE:** If you suspect that the tip guard or hose is clogged, or that pressure has not been fully relieved after following the steps above, very slowly loosen the tip guard retaining nut or hose end coupling to relieve pressure gradually, then loosen completely.

## Prime the System

1. Set the trigger safety latch. (FIG. 1)
2. Remove the spray tip from the gun, if it is installed. See Changing Spray Tips on page 10.
3. Be sure the air regulator handle is turned to zero (fully turned to the left).
4. Connect the air line to the pump.
5. Release the trigger safety latch.



6. Hold a metal part of the gun firmly against and aimed into a grounded metal pail. Squeeze the gun trigger and hold it open. (FIG. 6)

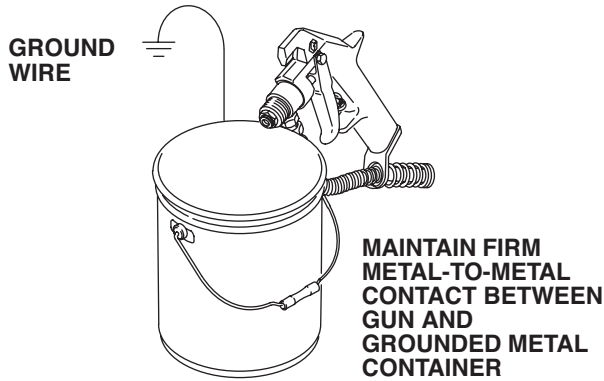


FIG. 6

7. Slowly open the air regulator until the run is running slowly and smoothly.
8. Dispense about 1 pint of masking liquid to be sure all air is pushed out of the system and the liquid flows freely.
9. Release the trigger and set the trigger safety latch. (FIG. 1)
10. Check all fluid connections for leaks; relieve pressure (see page 8) before tightening connections.

## Selecting a Tip

Two tips are provided with the gun. The size is marked on the cylinder handle. The size 621 tip comes installed on the tip guard. Each tip comes with a square ring and seal. Refer to Changing Spray Tips on page 11 and fig7.

- Use the 211 size tip for narrow surfaces such as door jambs.
- Use the 621 size tip for wide or larger surfaces.

## Installing the Spray Tip

### NOTICE

To avoid damaging the tip guard:

- Never use a wrench to turn the plastic tip guard, which causes internal damage.
- Never hang the gun by the tip guard.

1. Be sure the trigger safety latch is engaged.
2. Install the tip cylinder. Hold the cylinder with the arrow handle straight up. Push the cylinder into the tip guard so the flange on the cylinder fits into the slots at the base of the tip guard. (FIG. 7)

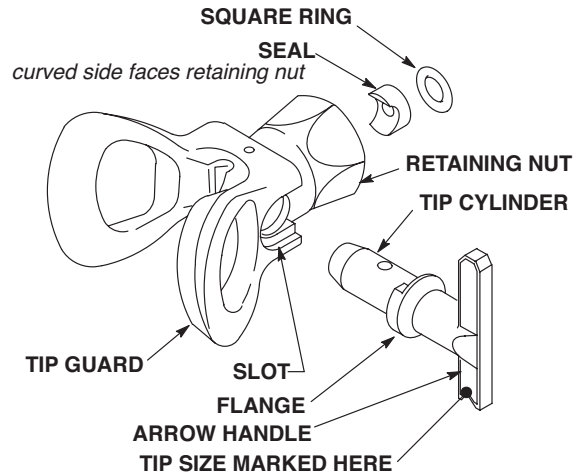


FIG. 7

3. Turn the arrow handle in the direction of the tip guard, which is the spraying position. (FIG. 8)

Rotate handle up and toward back of the gun then trigger the gun to clear an obstruction.

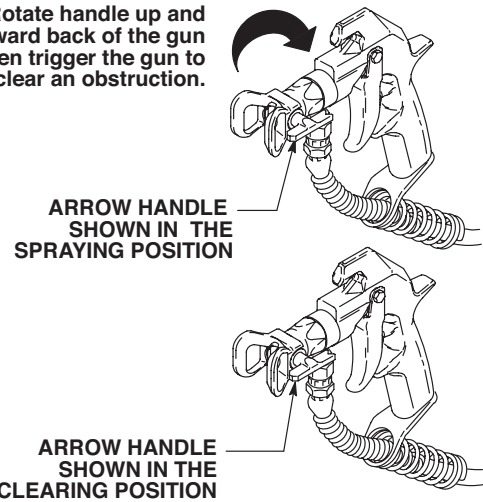


FIG. 8

**If the tip guard was removed from the gun and you are reinstalling it:**

4. Be sure the seal and square ring are in place as shown in FIG. 7. If not, place the seal on the end of a pencil with the curved side out. Guide the seal into the retaining nut and turn it until it straddles the cylinder. Drop in the square ring and press it down.

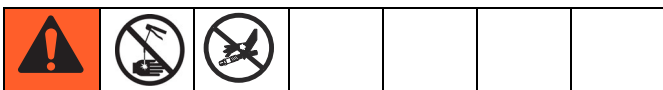
- Screw the retaining nut snugly onto the gun, holding the tip guard in the desired direction while tightening the nut. See Step 4 of Adjusting the Spray Pattern and Spraying Pressure on page 10 for more information on adjusting the direction of the spray pattern.

## Changing Spray Tips



- Relieve the pressure. See page 8.
- Rotate the arrow handle until it is straight up.
- Pull out the tip.
- Install the new tip and rotate it to the spraying position.

## Clearing a Clogged Spray Tip



- If the spray tip clogs, release the gun trigger, and set the trigger safety latch.
- Turn the arrow handle up and back toward the gun body. (FIG. 8)
- Release the trigger safety latch.
- Trigger the gun into a pail. This usually forces out the obstruction.
- Set the trigger safety latch again.
- Return the arrow handle to the spraying position.
- Release the trigger safety latch and resume spraying.
- If the tip is still clogged, close the air regulator, disconnect the air line, try triggering the gun into a pail, and open the drain valve.
- Remove the spray tip and clean it. Refer to manual 307848, supplied.

## Adjusting the Spray Pattern and Spraying Pressure

Refer to FIG. 9 for the following instructions.

**NOTE:** If the system is not primed, follow the Prime the System procedure on page 8.

- Set up a large piece of paper or cardboard to spray on for testing the spray pattern.
- Release the trigger safety latch.
- Aim the gun at the cardboard and trigger it briefly. Check the spray pattern. Adjust the air pressure just until spray from the gun is completely atomized. 3M recommends 80 to 90 psi (0.55 to 0.62 MPa, 5.5 to 6.2 bar) air pressure at the air inlet gauge for the best results.
- To adjust the direction of the spray pattern, set the trigger safety latch and loosen the tip guard retaining nut. (FIG. 7)
- Position the tip guard horizontally for a horizontal pattern or vertically for a vertical pattern.
- Retighten the retaining nut.

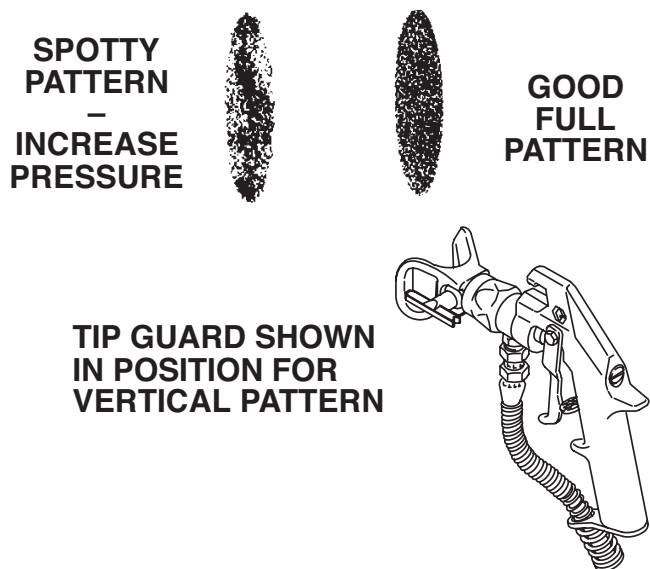


FIG. 9

## Practice Spraying

Read the spray techniques in Steps 1-5 below and FIG. 10 and FIG. 11, and follow 3M's recommendations on application of the masking liquid.

1. Begin triggering and moving gun just before first edge of target surface.

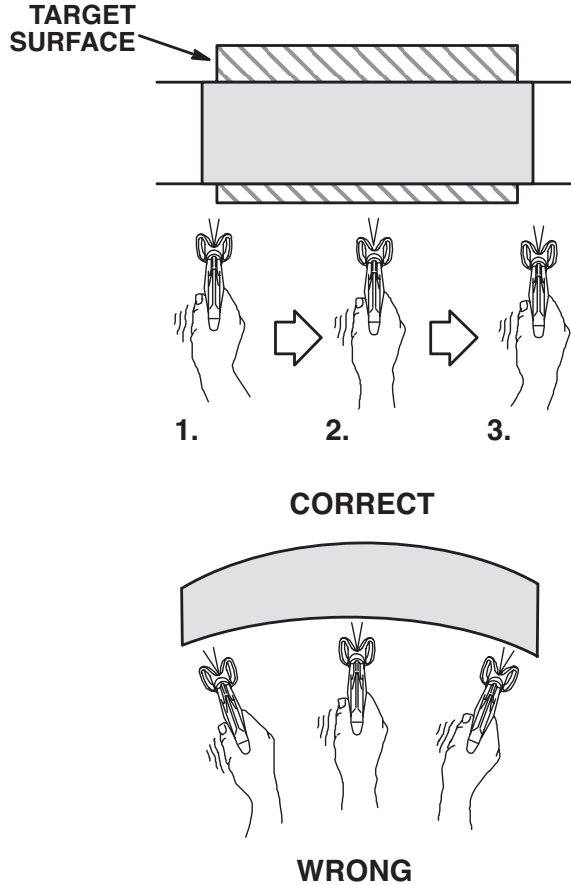


FIG. 10

2. Keep gun moving horizontally or vertically at a steady rate.
3. Release trigger just as you approach other edge of target surface, but keep the gun moving until it has passed the edge.
4. Hold the gun perpendicular (at right angles) to the target surface. Hold the gun as even 12 to 14" from the target surface. (FIG. 11)

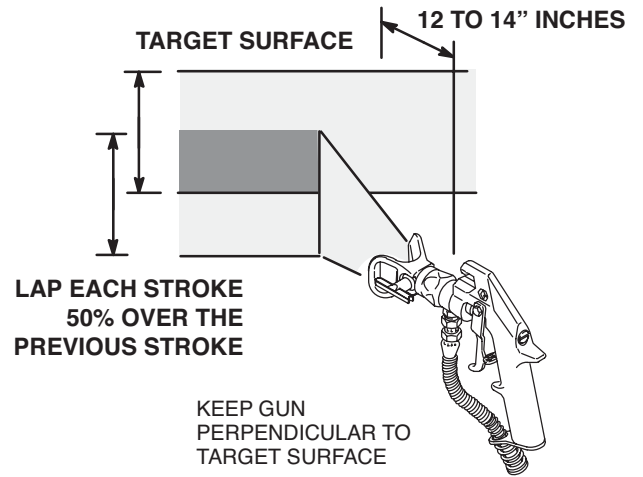


FIG. 11

5. Lap each stroke 50% over the previous stroke to produce a uniform material thickness. (FIG. 11)

# Maintenance



1. Keep the pump and hose fully primed with the masking liquid when it is not in use. This is done by relieving the pressure.

### NOTICE

Do not allow the supply container to be completely emptied. If that happens, the pump will start to run too fast and it could be damaged. If the pump starts to run too fast, disconnect the air line immediately. Prime the system with masking liquid (see page 8) or flush it as instructed in Weekly Flushing.

2. Lubricate the air motor daily. Disconnect the regulator, place about 15 drops of light machine oil in the pump air inlet, reconnect the regulator and turn on the air supply to blow oil into the motor.
3. If fluid drips steadily from the motor weep port, or the pump requires more than 35 psi (0.24 MPa, 2.4 bar) air pressure to cycle when the gun is triggered, adjust the packing nut. See Pump Packing Nut Adjustment, page 13.

## Weekly Flushing

### NOTICE

Thorough flushing is required at the end of each work week and before using a system that has been stored. Flushing keeps a system free of dried or aging material, such as discolored or jellied material.

#### Equipment Needed:

4 gallons warm water: use empty 3M container  
 5 gallon bucket for water  
 Cloth rags

1. Turn the air regulator handle to zero (fully left). Disconnect the air hose.
2. Remove the spray tip from the gun. (FIG. 7)

3. Pour 4 gallons of warm water into the empty 3M container.
4. Move the pump to the flushing container.
5. Connect the airline to the pump.
6. Release the trigger safety latch.
7. Aim the gun into the flushing pail and squeeze the gun trigger and hold it open.
8. Slowly open the air regulator until the pump is running slowly and smoothly.
9. Using very low pressure, direct the spray from the gun back into the flushing container. Circulate the water in this way for several minutes. Then release the trigger, set the trigger safety latch, and disconnect the air line to the pump.
10. Raise the pump out of the pail. trigger the gun to force the water from the system. **DO NOT** run the pump dry for more than 10 seconds to avoid damaging the pump packings.
11. Wash the exterior of the pump and all components with a cloth and water. Scrub any dirty areas and threads to remove residue.
12. Dry the pump and all components with a clean, dry cloth.

**NOTE:** If you plan to use the pump again soon, prime it with masking material.

**If you plan to store the pump**, continue as follows:

## Flushing Before Storing

1. Flush as in Steps 1 through 11, above, but use warm, soapy water.
2. Move the pump to a container of mineral spirits.

### NOTICE

Do not use paint solvents to flush, which will damage pump seals.

3. Trigger the gun into the flushing container. When mineral spirits appear at the fun, release the trigger and set the trigger safety latch. Remove the pump.
4. Release the trigger safety latch. Trigger the gun to force the mineral spirits from the system. **DO NOT** run the pump dry for more than 10 seconds to avoid pump packing damage.
5. Disconnect the hose and fun and store the pump.

3. Check to see that the air motor piston is at the top of the stroke. If it is not, **while keeping your fingers away from moving parts**, apply very low pressure air to the air inlet to move the piston up. Close the air regulator and disconnect the air supply hose. (FIG. 13)

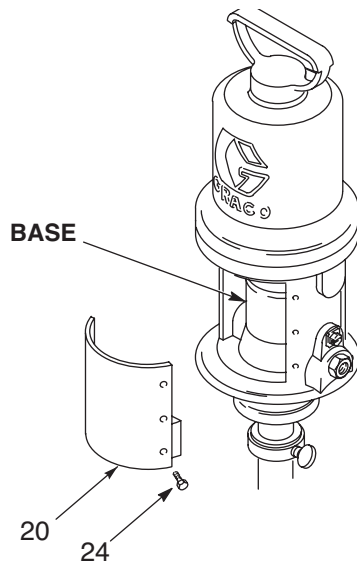
## Pump Packing Nut Adjustment



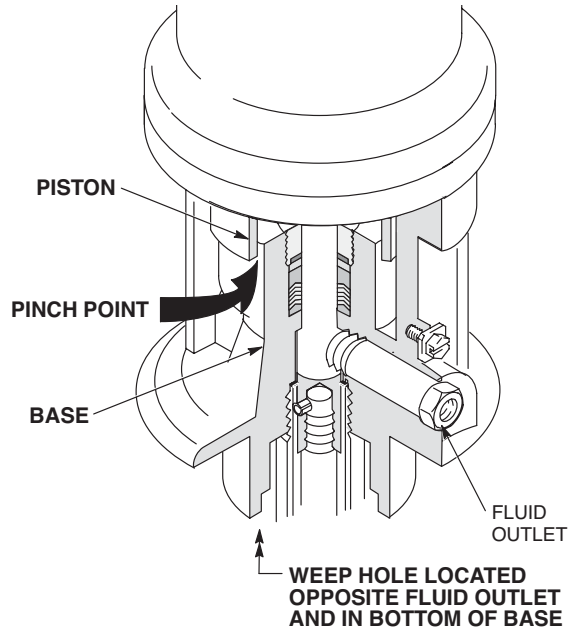
**NOTE:** Perform this adjustment if:

- a. Material drips steadily from the air motor weep hole, which indicates the packings are too loose.
- b. The pump requires more than 35 psi (0.24 MPa, 2.4 bar) air pressure to cycle when the gun is triggered, which indicates the packings are too tight.

1. Relieve the pressure. See Pressure Relief Procedure on page 8.
2. Remove the six screws (24) using a 1/4" nut driver. Remove the muffler plate. (FIG. 12)

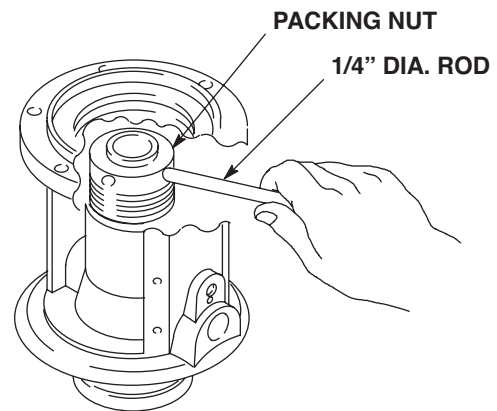


**FIG. 12**



**FIG. 13**






4. Use a 1/4" diameter rod to tighten the packing nut. First loosen the nut, then tighten snugly, and finally tighten 1/4 turn more. (FIG. 14)



**FIG. 14**

5. Replace the muffler cover and the six screws (24). (FIG. 12)
6. Reconnect the air line. After the pump is started, it should run at 20 psi (0.138 MPa, 1.38 bar) with no load. Start up may require additional air pressure.

# Troubleshooting

						
<p>Never operate the pump with the warning plate (20) or the identification plate (40) removed. These plates protect your fingers from pinching or amputation by moving parts in the air motor.</p>						

**NOTE:** Check all other possible problems and solutions before disassembling the pump.

Problem	Cause	Solution
Pump fails to operate	Low air supply pressure or restricted air lines	Increase air supply; clear*
	Closed valves	Open
	Clogged fluid lines, hoses, valves, etc.	Clear*
	Damaged air motor	Service air motor
	Empty fluid supply container	Refill and reprime, or flush
Continuous air exhaust	Worn or damaged air motor gasket, packing, seal, etc.	Service air motor
Erratic pump operation	Empty fluid supply container	Refill and reprime, or flush
	Held open or worn intake valve or piston packings	Clear; service
Pump operates, but output is low on the up stroke	Held open or worn piston or packings	Clear; service
Pump operates, but output is low on the down stroke	Held open or worn intake valve	Clear; service
Pump operates, but output is low on both strokes	Low air supply pressure or restricted air lines	Increase air supply; clear*
	Closed valves	Open
	Empty Fluid supply container	Refill and reprime, or flush
	Clogged fluid lines, hoses, valves, etc.	Clear*
	Packing nut is too tight	Loosen
	Loose packing nut or worn packings	Tighten; replace
Material drips steadily from weep port in motor base	Throat packing nut loose	Tighten packing nut
	Throat packing worn	Replace packing

Problem	Cause	Solution
Pump chattering	Packing nut too tight	Loosen packing nut
	Packing worn/material dried on I.D. of packing	Inspect/replace packing
	Material dried on rod	Clean or replace rod
Pump fails to prime	No material	Fill or replace container
	Air leak between intake valve and suction tube (55 gallon unit only)	Tighten or replace clamp or hose
	Material or other contamination on ball seats	Inspect and clean
	Intake ball stuck	Inspect, clean or replace
	Inlet strainer plugged	Clean strainer

\* **Relieve the Pressure.** Disconnect the fluid hoses. If the pump start when the air is turned on again, the hose or gun is clogged.

# Service

## Before Starting

Have all necessary parts on hand. Always replace the glands and bearing when replacing the packings. Use all the parts in the repair kits for the best results.

## Air Motor and Throat Disassembly



1. Flush the pump and relieve the pressure. See Pressure Relief Procedure on page 8.
2. Disconnect the hoses, remove the pump from its mounting, and clamp the air motor base in a vise.
3. Use a strap wrench on the riser tube (12) to screw it out of the air motor base (55).
4. Pull the connecting rod (10) down as far as it will go.
5. Use a hammer and punch to remove the roll pin (4). Unscrew the connecting rod (10). (FIG. 15)

### NOTICE

Do not damage the plated surface of the trip rod (54). Damaging the surface of the trip rod can result in erratic air motor operation. Use the special padded pliers, Part No. 207579, to grasp the rod.

6. Manually push up on the piston rod (41) to move the piston assembly (59) up as far as it will go. Unscrew the cap nut (47). Pull the nut up. Grip the trip rod (54) with padded pliers and screw the nut off the rod. (FIG. 15)

### NOTICE

To avoid damaging the cylinder wall, life the cylinder straight up off the piston. Never tilt the cylinder as it is being removed.

7. Remove the six screws (25). Pull the cylinder straight up off the piston. (FIG. 15)

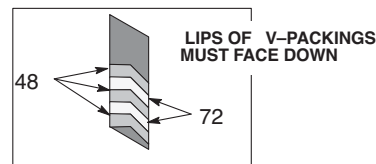
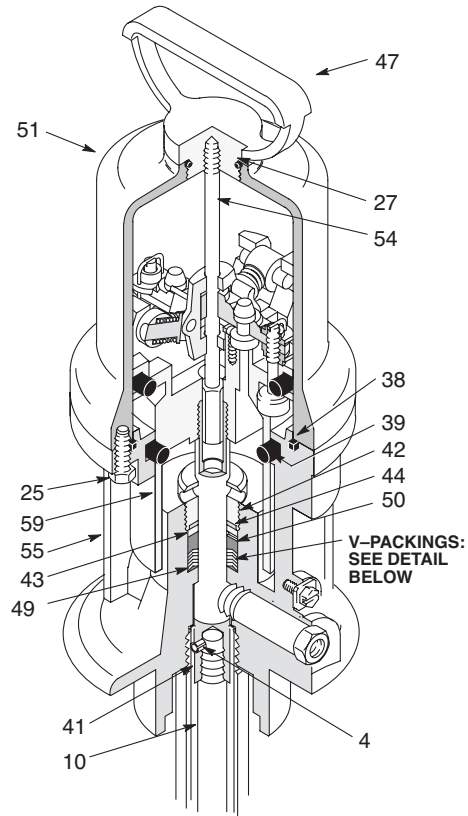


FIG. 15

8. Use a screw driver to push down on the trip rod yoke (28) and snap the toggles down. (FIG. 16)



## Air Motor and Throat Reassembly

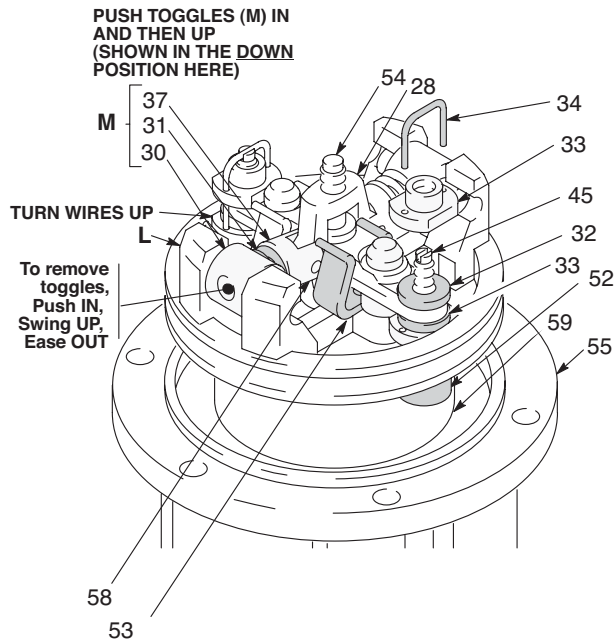


FIG. 16

- Remove the lockwires (34) from the adjusting nuts (33) of the transfer valves. Screw the top nuts off. Screw the stems (45) out of the grommets (32) and the bottom nuts (30). Take the valve poppets (52) off the stems and squeeze them firmly to check for cracks. (FIG. 16)

<p>To reduce the risk of pinching or amputating your fingers, always keep fingers clear of the toggle assemblies (N).</p>					

- Grip the pivot pins (30) with pliers. Compress the springs (31) and swing the toggle assembly (N) up and away from the piston lugs (L). Remove the parts. Check to see that the valve actuator (35) is supported by the spring clips (58), but slides easily into them. (FIG. 16)
- Remove the trip rod yoke (28), actuator (35) and trip rod (54). Check the exhaust valve poppets (53) for cracks. To remove the exhaust valve poppets (53), stretch them out and cut with a sharp knife. (FIG. 16)
- Remove one muffler plate (20 or 40). Pull the piston (59) up out of the base. Remove the throat packing nut (42) and packings. (FIG. 15)



- Clean all the parts in a compatible solvent and inspect for wear or damage. Check the polished surfaces of the piston, piston rod, and cylinder wall for scratches or wear. A scored rod will cause premature packing wear and leaking. Use all the repair kit parts and replace other parts as necessary.
- Lubricate all parts with a light, waterproof grease.
- One at a time, install these parts in the base (55): the gland (49), alternately install three reinforced packings (48) and two nitrile packings (72) with lips facing down, bearing (50), back up washer (43), flat packing (44), and loosely screw in the packing nut (42). Be sure the o-rings (38 and 39) are in place. (FIG. 15)
- Install the poppets (52) on the valve stems (45). Pull the exhaust valve poppets (53) into the valve actuator (35) and clip off the top parts shown with dotted lines. (FIG. 17)

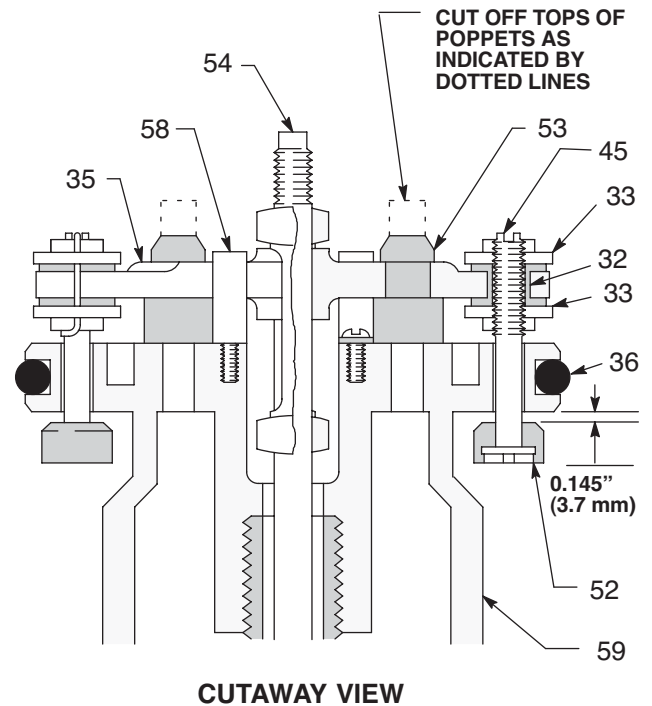


FIG. 17

5. Install the grommets (32) in the valve actuator (35). Install the trip rod (54) in the piston (59). Place the trip rod yoke (28) and valve actuator (35) on the trip rod. Be sure the o-ring (36) is in place and that the valve actuator is supported by the spring clips (58), and then reassemble the valve mechanism. (FIG. 16)
6. Install the bottom adjusting nuts (33) on the valve stems (45) and screw the stems into the grommets (32). Screw the top nuts (33) on the stems. Tighten the nuts (33) just enough to slightly compress the grommet (32). Before installing the lockwires (34) in the adjusting nuts, use the special gauge, Part No. 171818, to adjust the transfer valve so there is 0.145 in. (3.7 mm) clearance between the poppets (52) and the seat when it is open. (FIG. 17)
7. Install the springs (31) and pivot pins (30) on the toggle arms (37). Snap the toggles to the up position. (FIG. 16)
8. Carefully lower the cylinder (51) over the piston (59) and onto the base (55). Secure with the six screws (25).
9. Manually push on the piston rod (41) to move the piston (59) up as far as it will go. Grip the trip rod (54) with padded pliers and screw the cylinder cap nut (47) onto the trip rod. Pull the piston rod (41) to move the piston downward. Be sure the o-ring (27) is in place at the top of the cylinder (51), and then screw the cap nut into the cylinder.
10. Screw the connecting rod (10) into the piston rod (41) and secure with the pin (4). Screw the riser tube (12) into the base (55).
11. Install the muffler plates (20, 40). Tighten the throat packing nut (42) just until snug.
12. Connect an air hose and run the pump slowly (about 30 psi [0.24 MPa, 2.4 bar]) to see that it operates smoothly.
13. Remount the pump and reconnect the ground wire.

## Displacement Pump Disassembly



Before starting have all necessary parts on hand. Always replace the glands and bearing when replacing the packings. Use all the parts in the repair kits for the best results.

1. Flush the pump and relieve the pressure. See Pressure Relief Procedure, page 8.
2. Disconnect the hoses, remove the pump from its mounting, and clamp the air motor base in a vise.
3. Unscrew the intake valve body (22) from the riser tube (12). (FIG. 18)
4. Disassemble the intake valve.
5. Clean and inspect the parts for wear or damage, and replace parts as needed. Unless further service is needed, reassemble and reinstall the intake valves, using liquid sealant on the male threads. (FIG. 18)
6. Use a strap wrench on the riser tube (12) to screw it out of the air motor base (55). Carefully inspect the smooth inner surface of the cylinder for scoring or irregular surfaces. Such damage causes premature packing wear and leaking. Replace part if damaged.
7. Unscrew the piston body (13) from the piston coupling (14). Remove the ball (2), seat (19), gasket (6), bearing (18), packing (17), and seal (16). Do not remove the press-fit brass bearing (15). (FIG. 18)

**NOTE:** If the pressure-fit brass bearing (15) needs to be replaced, clamp it in a vise and drive the piston body (13) out with a plastic hammer. The new bearing **must** be started onto the piston body squarely.

## Displacement Pump Reassembly

1. Clean and inspect the parts and replace any that are worn or damaged. Be sure to check the copper gasket (46) in the motor base (55). Lubricate the parts with a light, waterproof grease.
2. Install the seal (16), packing (17), bearing (18), gasket (6), seat (19), and ball (2) on the piston body (13). The check ball seat (19) may be reversed, if needed, to provide a new seat. Screw the piston body (13) into the piston coupling (14).
3. Screw the riser tube (12) into the air motor base (55).
4. Reinstall the ball (3), gasket (7), ball stop (21) and other gasket (7) in the intake valve housing (22). Screw the housing onto the riser tube (12).
5. Be sure the ground wire is connected before regular operation of the pump.

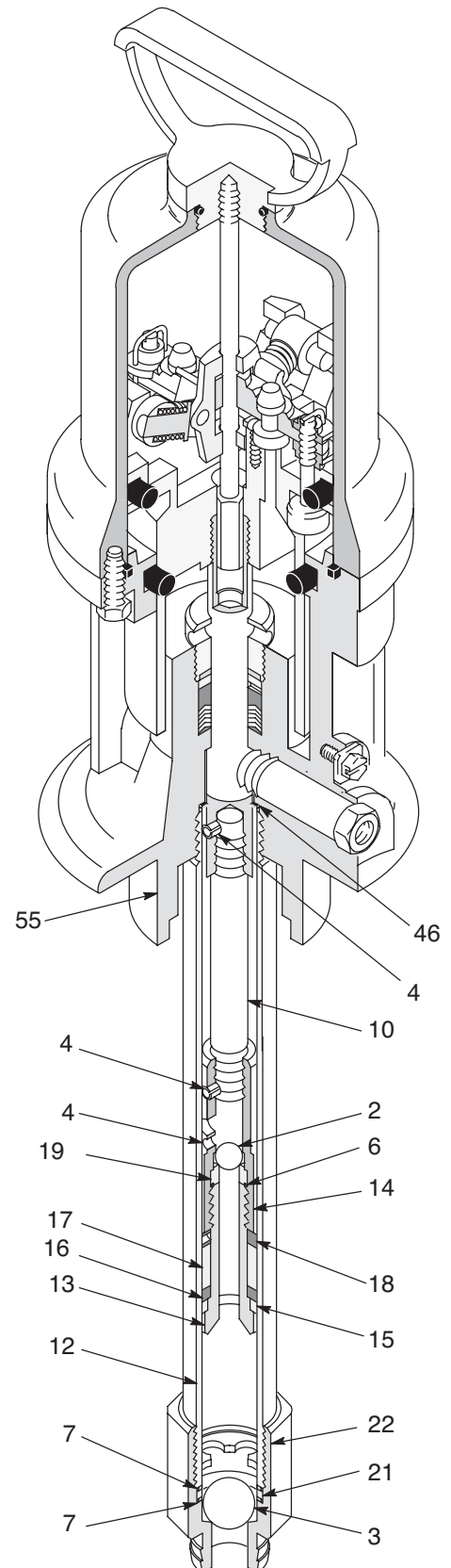
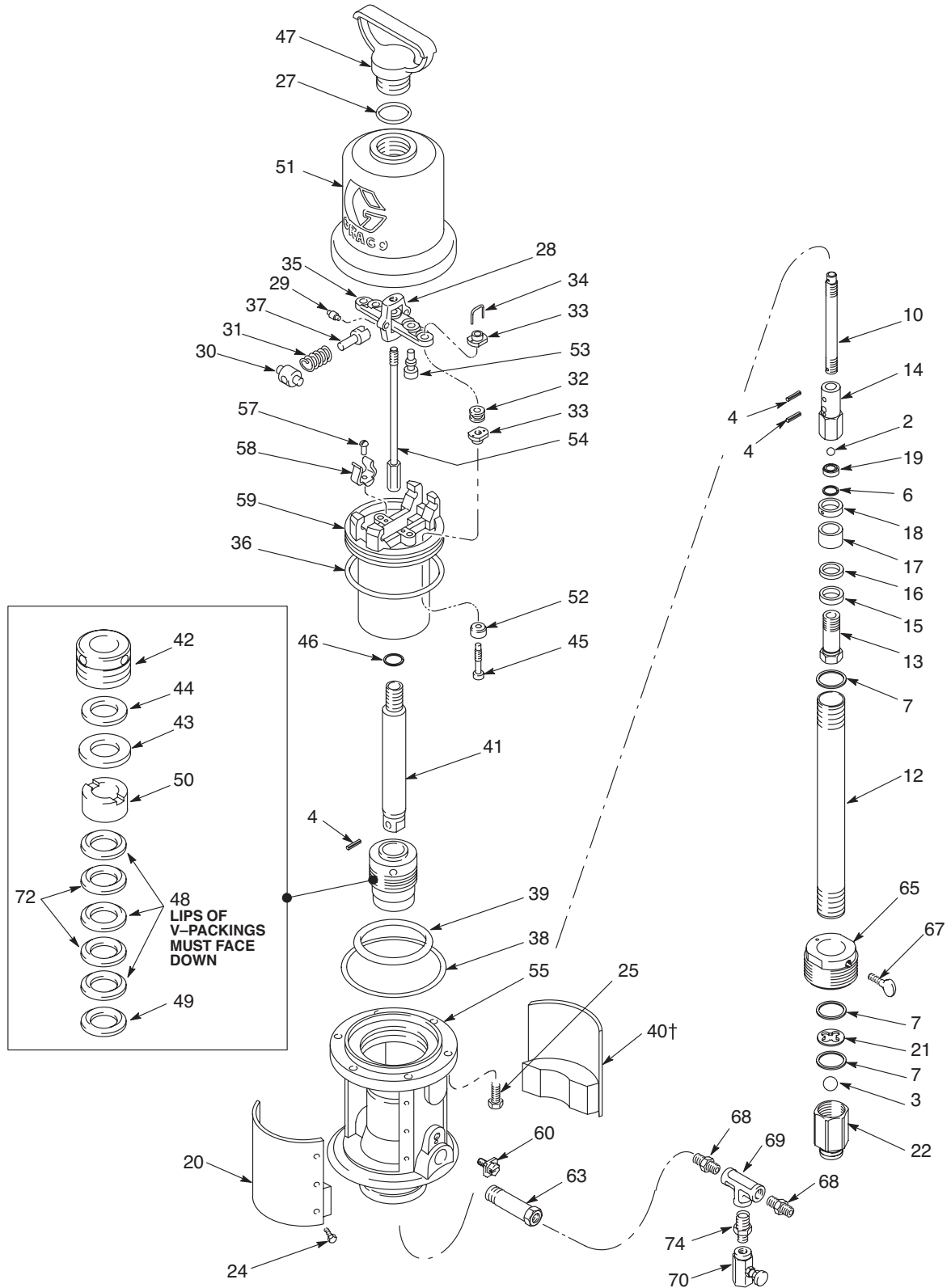


FIG. 18

# Parts

Model 224825, Series A

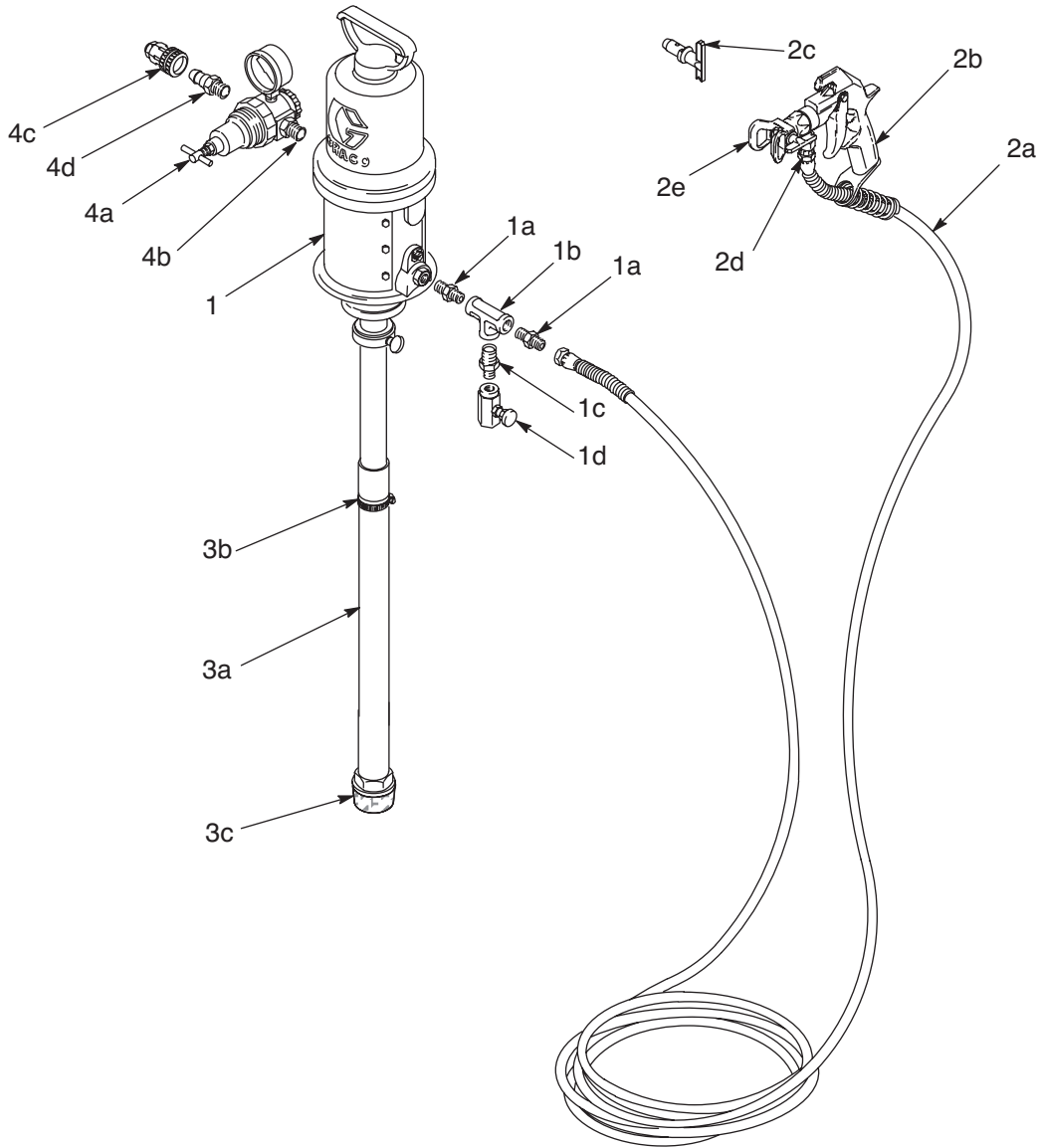


**Model 224825, Series A**

Ref.	Part	Description	Qty.	Ref.	Part	Description	Qty.
				37	160623	ARM, toggle	2
				38	160624	O-RING, nitrile rubber	1
2❖	103075	BALL, sst, 0.44 in (11.2 mm) dia	1	39*	160625	O-RING, nitrile rubber	1
3❖	101859	BALL, sst, 0.75 in (19 mm) dia	1	40†	234577	PLATE, identification, with muffler	1
4❖	101871	PIN, roll, 0.12 in (3.2 mm) dia, 0.75 in (19 mm) long	3	41	187749	ROD, piston	1
6❖	150451	GASKET, copper	1	42	187756	NUT, packing	1
7	150694	GASKET, copper	3	43	187757	WASHER, backup	1
10	187743	ROD, connecting, 5-1/4" (133 mm) long	1	44❖	160644	PACKING, flat leather	1
12	187746	TUBE, riser, 11-11/16" (279 mm) long	1	45*	160896	STEM, valve	2
13	187745	BODY, piston	1	46	160932	GASKET, copper	1
14	187744	COUPLING, piston	1	47	164704	NUT, cylinder cap	1
15❖	160941	BEARING, press fit, brass	1	48❖	111688	V-PACKING, reinforced nitrile	3
16❖	160942	SEAL, piston, PTFE	1	49❖	187755	GLAND, male	1
17❖	160943	PACKING, block, nitrile rubber	1	50❖	187856	BEARING, throat	1
18❖	160944	BEARING, piston, brass	1	51	160613	CYLINDER, air motor	1
19❖	187753	SEAT, piston, reversible	1	52*	170708	POPPET, valve, urethane	2
20†	234578	PLATE, warning (with muffler)	1	53*	170709	POPPET, valve, urethane	2
21	187748	STOP, ball	1	54	203965	ROD, trip	1
22	187747	HOUSING, intake valve	1	55	224823	BASE, air motor	1
23	224824	AIR MOTOR ASSEMBLY, Series A, includes items 20, 24 - 63	1	57	102975	SCREW, rd hd mach, 6-32 x 1/4"	2
24†	100078	SCREW, hex washer hd, mach, 8-32 x 3/8"	12	58	172866	CLIP, spring	2
25	101578	CAPSCREW, hex hd Nylock, 5/16-18 x 7/8"	6	59	160614	PISTON, air motor	1
27	156698	O-RING, nitrile rubber	1	60	116343	SCREW, ground	1
28	158360	YOKE, rod, trip	1	63	187752	ADAPTER, 3/8 npt (m) x 1/4 npt (f)	1
29	158362	PIN, toggle	2	65	187754	BUNG ADAPTER	1
30	158364	PIN, pivot	2	67	100200	THUMBSCREW	1
31	167585	SPRING, helical compression	2	68	166421	NIPPLE, 1/4 npt	2
32*	158367	GROMMET, rubber	2	69	103696	TEE, 1/4 npt (f)	1
33*	160261	NUT, adjusting	4	70	111521	DRAIN VALVE	1
34*	160618	WIRE, lock	2	72	111642	V-PACKING, nitrile rubber	2
35	172867	ACUTATOR, valve	1	74	111643	NIPPLE, 1/4 x 1/8 npt	1
36*	160621	O-RING, nitrile rubber	1				

❖ *Parts included in Kit 235136 (purchase separately).*\* *Parts included in Kit 206728 (purchase separately).*† *Parts included in Kit 222559 (purchase separately).*

**Model 224826, Stainless Steel System**

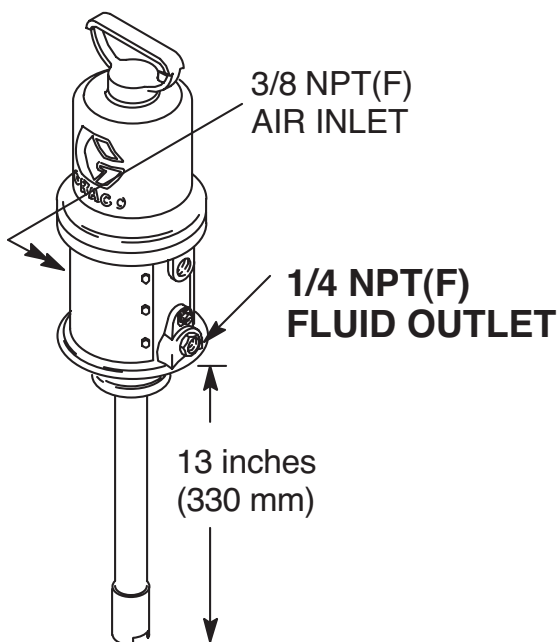


Ref.	Part	Description	Qty.	Ref.	Part	Description	Qty.
1	224825	15:1 FIRE-BALL® 300 PUMP, See pages 22 and 23 for parts, includes items 1a to 1d	1	2d	286621	SPRAY TIP, size 621, installed in tip guard	1
1a	166421	NIPPLE, 1/4 npt	2	2e	243161	TIP GUARD, RAC V	1
1b	104984	TEE, 1/4 npt (f)	1	3	224022	SUCTION HOSE, includes items 3a to 3c	1
1c	111521	DRAIN VALVE	1	3a	110979	HOSE, suction	1
1d	111643	NIPPLE, 1/4 x 1/8 npt	1	3b	110980	HOSE CLAMP	1
2	224023	SPRAY GUN AND HOSE ASSEMBLY, includes items 2a to 2e	1	3c	187542	STRAINER	1
2a	223540	SPRAY HOSE, 25 ft (7 m) cpld 1/4 npsm (fbe), spring guards both ends	1	4	224024	AIR REGULATOR ASSEMBLY, includes items 4a to 4d	1
2b	248157	SPRAY GUN, see manual 309741 for parts	1	4a	109075	AIR REGULATOR, see manual 308167 for parts	1
2c	286211	SPRAY TIP, size 211	1	4b	156849	NIPPLE	1
				4c	208536	COUPLER, quick disconnect	1
				4d	169971	NIPPLE, quick disconnect	1

# Technical Data

Overspray Masking Liquid System		
	US	Metric
Maximum fluid working pressure	2700 psi	18.6 MPa, 186 bar
Air pressure operating range	40-180 psi	0.3-1.2 MPa, 3-12 bar
Fluid pressure ratio	15:1	
Air motor effective diameter	3 inches	76 mm
Stroke	3 inches	76 mm
Air consumption	17 cfm/gallon pumped at 100 psi (0.476 m <sup>3</sup> /liter at 0.7 MPa, 7 bar) up to 30 cfm with pump operating at 180 psi and 66 cycles/pin (up to 84 m <sup>3</sup> /min with pump operated at 1.2 MPa, 12 bar and 66 cycles/min.)	
Pump cycles per gallon (liter)	90	
Delivery	0.66 gallons/minute	3 liters/minute
Maximum recommended pump speed	66 cycles/minutes; 0.7 gpm (32 liter/minute)	
Recommended speed for optimum pump life	15 to 25 cycles/ minute	
Wetted parts	Stainless steel, aluminum, nitrile rubber, PTFE, brass, copper, leather	
Dimensions	See below	

## Dimensions



# Graco Standard Warranty

Graco warrants all equipment referenced in this document which is manufactured by Graco and bearing its name to be free from defects in material and workmanship on the date of sale to the original purchaser for use. With the exception of any special, extended, or limited warranty published by Graco, Graco will, for a period of twelve months from the date of sale, repair or replace any part of the equipment determined by Graco to be defective. This warranty applies only when the equipment is installed, operated and maintained in accordance with Graco's written recommendations.

This warranty does not cover, and Graco shall not be liable for general wear and tear, or any malfunction, damage or wear caused by faulty installation, misapplication, abrasion, corrosion, inadequate or improper maintenance, negligence, accident, tampering, or substitution of non-Graco component parts. Nor shall Graco be liable for malfunction, damage or wear caused by the incompatibility of Graco equipment with structures, accessories, equipment or materials not supplied by Graco, or the improper design, manufacture, installation, operation or maintenance of structures, accessories, equipment or materials not supplied by Graco.

This warranty is conditioned upon the prepaid return of the equipment claimed to be defective to an authorized Graco distributor for verification of the claimed defect. If the claimed defect is verified, Graco will repair or replace free of charge any defective parts. The equipment will be returned to the original purchaser transportation prepaid. If inspection of the equipment does not disclose any defect in material or workmanship, repairs will be made at a reasonable charge, which charges may include the costs of parts, labor, and transportation.

**THIS WARRANTY IS EXCLUSIVE, AND IS IN LIEU OF ANY OTHER WARRANTIES, EXPRESS OR IMPLIED, INCLUDING BUT NOT LIMITED TO WARRANTY OF MERCHANTABILITY OR WARRANTY OF FITNESS FOR A PARTICULAR PURPOSE.**

Graco's sole obligation and buyer's sole remedy for any breach of warranty shall be as set forth above. The buyer agrees that no other remedy (including, but not limited to, incidental or consequential damages for lost profits, lost sales, injury to person or property, or any other incidental or consequential loss) shall be available. Any action for breach of warranty must be brought within two (2) years of the date of sale.

**GRACO MAKES NO WARRANTY, AND DISCLAIMS ALL IMPLIED WARRANTIES OF MERCHANTABILITY AND FITNESS FOR A PARTICULAR PURPOSE, IN CONNECTION WITH ACCESSORIES, EQUIPMENT, MATERIALS OR COMPONENTS SOLD BUT NOT MANUFACTURED BY GRACO.** These items sold, but not manufactured by Graco (such as electric motors, switches, hose, etc.), are subject to the warranty, if any, of their manufacturer. Graco will provide purchaser with reasonable assistance in making any claim for breach of these warranties.

In no event will Graco be liable for indirect, incidental, special or consequential damages resulting from Graco supplying equipment hereunder, or the furnishing, performance, or use of any products or other goods sold hereto, whether due to a breach of contract, breach of warranty, the negligence of Graco, or otherwise.

## **FOR GRACO CANADA CUSTOMERS**

The Parties acknowledge that they have required that the present document, as well as all documents, notices and legal proceedings entered into, given or instituted pursuant hereto or relating directly or indirectly hereto, be drawn up in English. Les parties reconnaissent avoir convenu que la rédaction du présente document sera en Anglais, ainsi que tous documents, avis et procédures judiciaires exécutés, donnés ou intentés, à la suite de ou en rapport, directement ou indirectement, avec les procédures concernées.

# Graco Information

For the latest information about Graco products, visit [www.graco.com](http://www.graco.com).

**TO PLACE AN ORDER**, contact your Graco distributor or call to identify the nearest distributor.

**Phone:** 612-623-6928 or **Toll Free:** 1-800-533-9655, **Fax:** 612-378-3590

*All written and visual data contained in this document reflects the latest product information available at the time of publication.  
Graco reserves the right to make changes at any time without notice.*

*For patent information, see [www.graco.com/patents](http://www.graco.com/patents).*

Original instructions. This manual contains English. MM 308069

**Graco Headquarters:** Minneapolis  
**International Offices:** Belgium, China, Japan, Korea

**GRACO INC. AND SUBSIDIARIES • P.O. BOX 1441 • MINNEAPOLIS MN 55440-1441 • USA**

**Copyright 1990, Graco Inc. All Graco manufacturing locations are registered to ISO 9001.**

[www.graco.com](http://www.graco.com)

Revised January 2013