

Pulse[®] Universal Controller

3A9505B

EN

For reading, controlling, and reporting fluid dispenses by wireless communication with a Pulse Fluid Management System. For professional use only.

Not approved for use in explosive atmospheres or hazardous (classified) locations.

See page 3 for model information.



Important Safety Instructions

Read all warnings and instructions in this manual and in related Pulse System manuals before using the equipment. Be familiar with the proper control and usage of the equipment. Save these instructions.



Contains Model XBee S2C Radio, IC: 1846A-XBS2C.

The dispense controller contains FCC ID MCQ-XBS2C. This device complies with Part 15 of the FCC Rules. Operation is subject to the following two conditions:

- This device may not cause harmful interference.
- This device must accept any interference received, including interference that may cause undesired operation.

Contents

Models	3	Recycling and Disposal	24
Safety Symbols	4	End of Product Life.	24
General Warnings	5	Troubleshooting	25
Component Identification	6	Fault Codes	27
Typical Installation	7	Definition of Terms	28
Pneumatic Pump System	7	Repair	29
Electric Pump System	8	Battery Replacement	29
Installation	9	Dimensions	30
Mounting	9	Mounting Pattern	30
Wiring.....	9	Technical Specifications	31
Wiring Key	9	California Proposition 65	31
Controller Power Supply	9	Graco Standard Warranty	32
Pump Control Signal	9		
Meter Signal	9		
Setup	11		
Main Menu Screen.....	11		
REGISTER	11		
Calibrate the Dispense Controller	12		
Alternate Calibration.....	13		
Security Authorization	14		
Utility Menu Codes	14		
PIN Codes	14		
Authorization Using an NFC FOB	15		
Operation	16		
Dispense Menus	16		
Manual Dispense Screens.....	16		
Preset Dispense Screens	16		
Work Orders	18		
Work Orders Created Using Pulse Fluid Management Software	19		
Work Orders Created On The Dispense Controller	19		
Asset Dispense Screens	19		
Setup Menus	21		
Device Information	21		
REGISTER.....	21		
GO BACK	21		
Sync Menus - Model 25V711 Only	21		
Utility Menus	22		
UPGRADE	22		
WORK OFFLINE	22		
CALIBRATE	22		
MANUAL LIMIT	22		
FLIP DISPLAY	22		
ADVANCED SETTINGS	22		
GO BACK	23		

Models

Model No.	Description
25V710	Pulse Pro Universal Controller
25V711	Pulse Asset Universal Controller

Safety Symbols

The following safety symbols appear throughout this manual and on warning labels. Read the table below to understand what each symbol means.

Symbol	Meaning
	Electric Shock Hazard
	Equipment Misuse Hazard
	Fire and Explosion Hazard
	Follow Pressure Relief Procedure
	Ground Equipment
	Read Manual
	Wear Personal Protective Equipment









Safety Alert Symbol

This symbol indicates: Attention! Become Alert! Look for this symbol throughout the manual to indicate important safety messages.

General Warnings

The following warnings apply throughout this manual. Read, understand, and follow the warnings before using this equipment. Failure to follow these warnings can result in serious injury.

 <h1 style="margin: 0;">WARNING</h1>	
 	<p>EQUIPMENT MISUSE HAZARD Misuse can cause death or serious injury.</p> <ul style="list-style-type: none"> • Do not operate the unit when fatigued or under the influence of drugs or alcohol. • Do not exceed the maximum working pressure or temperature rating of the lowest rated system component. See Technical Specifications in all equipment manuals. • Use fluids and solvents that are compatible with equipment wetted parts. See Technical Specifications in all equipment manuals. Read fluid and solvent manufacturer’s warnings. For complete information about your material, request Safety Data Sheets (SDSs) from distributor or retailer. • Turn off all equipment and follow the Pressure Relief Procedure when equipment is not in use. • Check equipment daily. Repair or replace worn or damaged parts immediately with genuine manufacturer’s replacement parts only. • Do not alter or modify equipment. Alterations or modifications may void agency approvals and create safety hazards. • Make sure all equipment is rated and approved for the environment in which you are using it. • Use equipment only for its intended purpose. Call your distributor for information. • Route hoses and cables away from traffic areas, sharp edges, moving parts, and hot surfaces. • Do not kink or over bend hoses or use hoses to pull equipment. • Keep children and animals away from work area. • Comply with all applicable safety regulations.
 	<p>FIRE AND EXPLOSION HAZARD When flammable fluids are present in the work area, such as gasoline and windshield wiper fluid, be aware that flammable fumes can ignite or explode. To help prevent fire and explosion:</p> <ul style="list-style-type: none"> • Use equipment only in well-ventilated area. • Eliminate all ignition sources, such as cigarettes and portable electric lamps. • Ground all equipment in the work area. • Keep work area free of debris, including rags and spilled or open containers of solvent and gasoline. • Do not plug or unplug power cords or turn lights on or off when flammable fumes are present. • Use only grounded hoses. • Stop operation immediately if static sparking occurs or you feel a shock. Do not use equipment until you identify and correct the problem. • Keep a working fire extinguisher in the work area.
	<p>PERSONAL PROTECTIVE EQUIPMENT Wear appropriate protective equipment when in the work area to help prevent serious injury, including eye injury, hearing loss, inhalation of toxic fumes, and burns. Protective equipment includes but is not limited to:</p> <ul style="list-style-type: none"> • Protective eyewear, and hearing protection. • Respirators, protective clothing, and gloves as recommended by the fluid and solvent manufacturer.

Component Identification

NOTICE

To prevent damage to soft key buttons, do not press the buttons with sharp objects such as pens, plastic cards, screwdrivers, or fingernails.

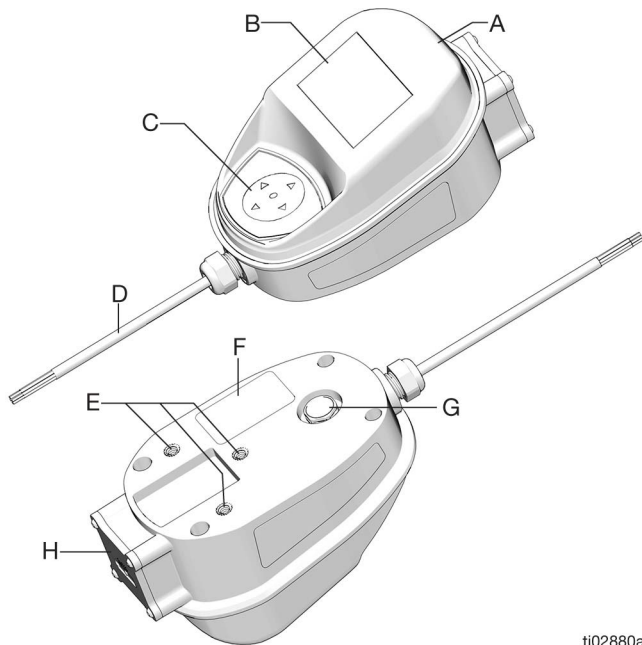

ti02880a

FIG. 1

Key

- A NFC Zone
- B Display
- C Navigation Pad
- D Input/Output Wiring Harness
- E Mounting Locations
- F Identification Label
- G Pressure Relief Vent
- H Battery Compartment

The Navigation pad (C) includes four navigation arrows (UP, DOWN, LEFT, RIGHT) and a center button (ENTER).

ARROWS: Moves the cursor on the display.

ENTER: Selects or stores an entry.

The following information appears at the top of the Work Offline and Dispense screens.

Dispense Controller Name: Unique identification. Configured in the Pulse Fluid Management Software.

RF Signal Strength: Displays the recorded strength of the signal received by the dispense controller, indicated by the number of bars displayed on the screen (1-4).

Battery Indicator: When the batteries are fully charged, or the controller is externally powered, the battery icon is completely filled. As the battery discharges, the icon indicates the decline. When the low battery symbol displays (FIG. 2), replace the batteries. See **Battery Replacement**, page 29.



ti01235a

FIG. 2

NOTE: The Pulse Fluid Management Software, set up by the system administrator, manages the operating parameters of the dispense controller. For more information, see **Setup**, page 11.

Typical Installation

Pneumatic Pump System

The installation shown in FIG. 3 is only a guide for selecting and installing system components and accessories. Contact your Graco distributor for assistance in designing a system to meet your needs.

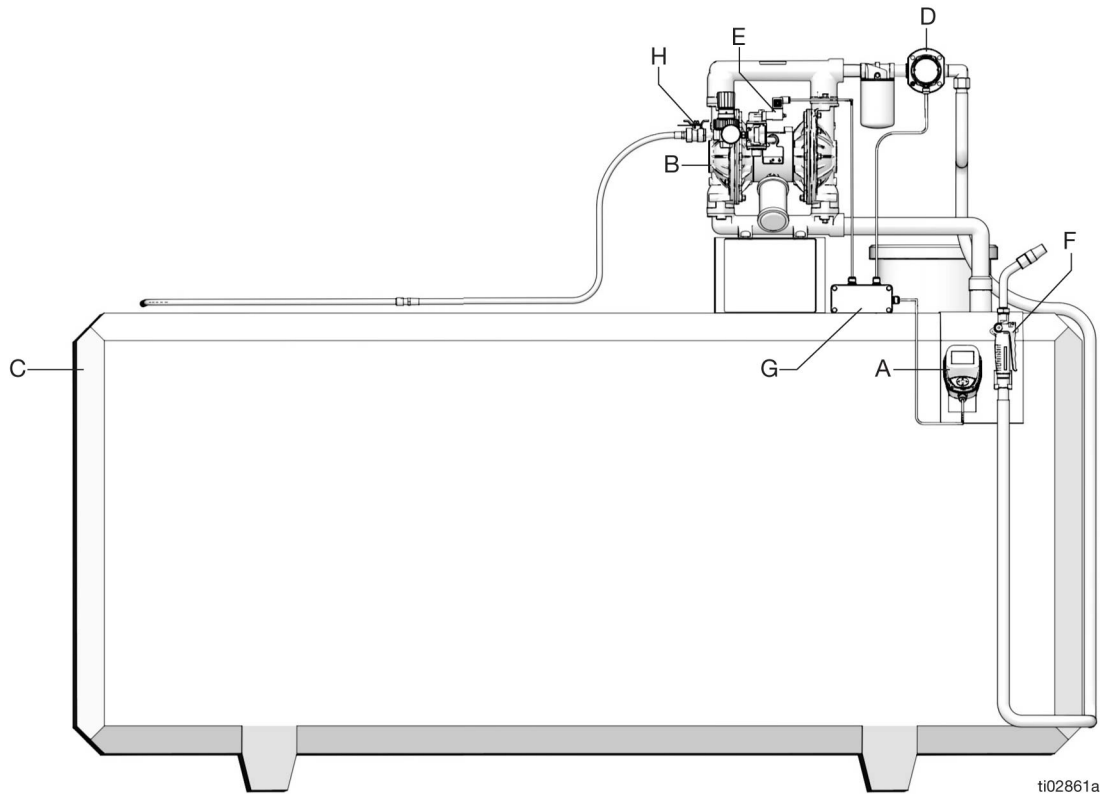

ti02861a

FIG. 3: Typical Installation: Pneumatic Pump System

Key:

- A Pulse Universal Controller
- B Pneumatic Pump
- C Fluid Tank
- D Fluid Meter with Pulser Output
- E Air Solenoid Valve
- F Dispense Valve/Nozzle
- G Power Supply and Air Control Relay
- H Manual Air Shut-Off Valve

NOTE: Only the Pulse Universal Controller (A) is included. All other components are user supplied.

Electric Pump System

The installation shown in FIG. 4 is only a guide for selecting and installing system components and accessories. Contact your Graco distributor for assistance in designing a system to meet your needs.

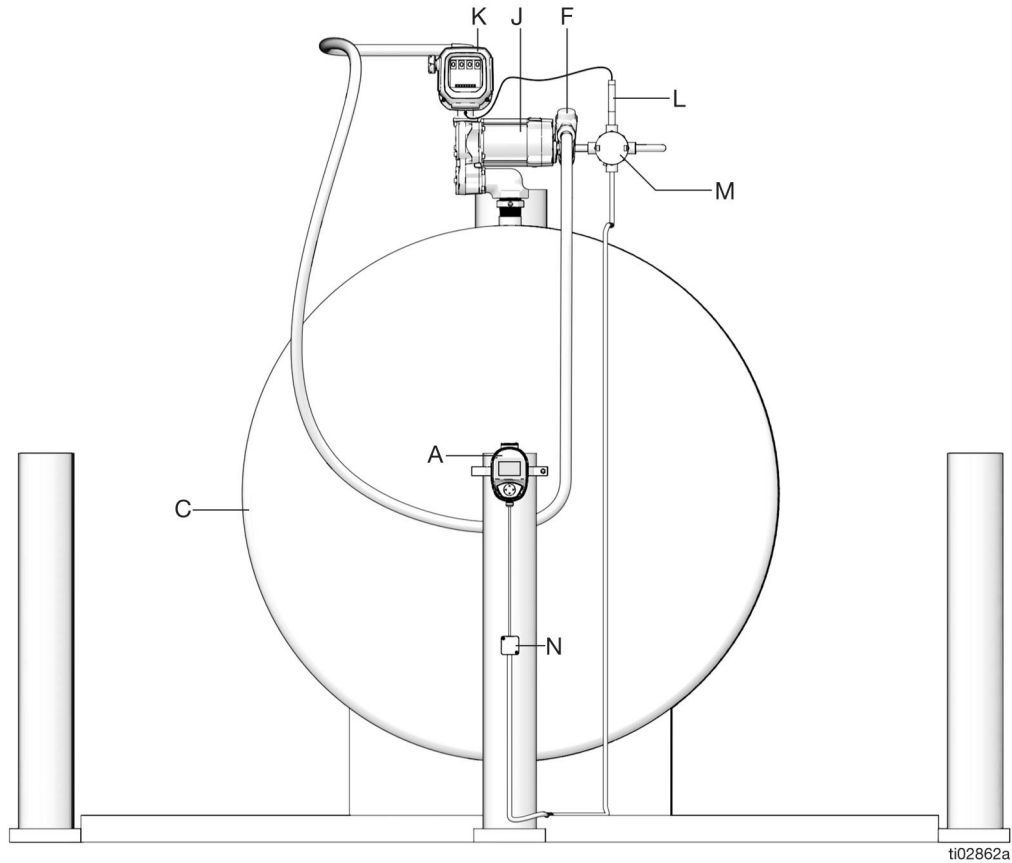

FIG. 4: Typical Installation: Electric Pump System

Key:

- A Pulse Universal Controller
- C Fluid Tank
- F Dispense Valve/Nozzle
- J Electric Pump
- K Dispense Register
- L Dispense Pulsar
- M Pump Relay
- N Emergency Stop

NOTE: Only the Pulse Universal Controller (A) is included. All other components are user supplied.

Installation

Mounting

1. Select a flat, rigid surface to install the Pulse Universal Controller. The surface should be large enough to fully cover the rear mounting surface.
2. Drill the mounting holes, refer to **Mounting Pattern**, page 30, and the corresponding orientation.
3. Align the controller housing with the drilled holes.
4. Secure the controller using three, user supplied, 1/4 in.-20 fasteners.

NOTICE

Ensure that any fasteners used does not extend into the housing more than 1/2 in. (12 mm) to avoid damage to the controller. See Fig. 5

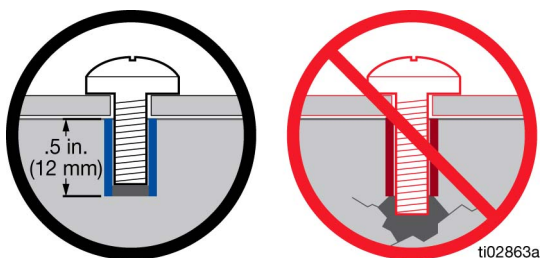

FIG. 5

NOTICE

Do not tighten fasteners with torque greater than 10 in.-lb (1.1 N•m). Exceeding this limit may cause damage to the unit.

Wiring

All electrical wiring must be done by a qualified electrician and comply with all local codes and regulations.					

The controller comes with a 4 ft (1.2 m) flying lead cable that has six internal wires, see **Wiring Key**.

Wiring Key

Wire Color	Description
Red	Controller Power Supply (+)
Black	Controller Power Supply (-)
White	Pump Control Signal (+)
Green	Pump Control Signal (-)
Blue	Meter Signal
Brown	Meter Signal

Controller Power Supply

Power the controller by an external 6-12 Volt DC power supply (user supplied). The controller can be optionally powered by the internal battery pack (4-AA).

Pump Control Signal

The controller outputs a 6 Volt DC signal on the pump control signal wires when a dispense is activated. The signal is limited to supplying 500 mA of current by an internal, thermally resettable fuse. This signal can be used to drive a non-latching relay to turn a pump on or off.

NOTE: When the pump control signal is used, an external power supply is required.

Meter Signal

The controller continuously monitors the meter signal lines to detect and record fluid flow.

NOTE: The Pulse Controller is only compatible with passive, reed-switch-style, pulse output meters. Contact your Graco distributor for assistance in selecting a compatible meter.

When not in use, the signal lines are supplied with a steady electric potential of 3.3 Volts (maximum supply current of 10 uA). An external meter device (pulser), needs to pull this signal low each time a fixed amount of fluid passes through it. At the occurrence of the falling edge, a dispense pulse is recorded by the controller (FIG. 6).

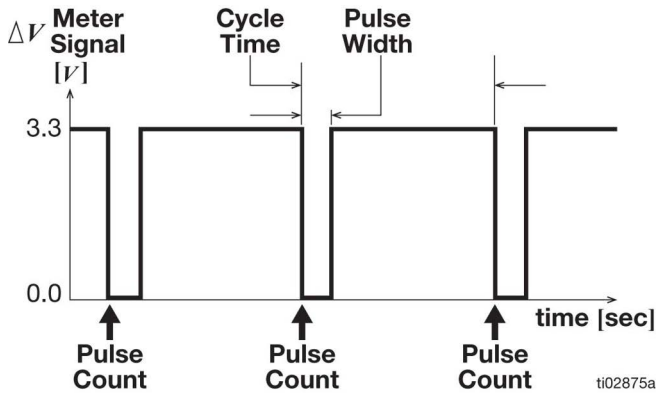

NOTE: The maximum rate a dispense pulse can reliably be detected depends on the quality and shape of the signal. The maximum recommended pulse rate for most applications is 200 Hz.

An example wiring diagram is shown in FIG. 7 to demonstrate the overall architecture. This is not an actual system design.

FIG. 6

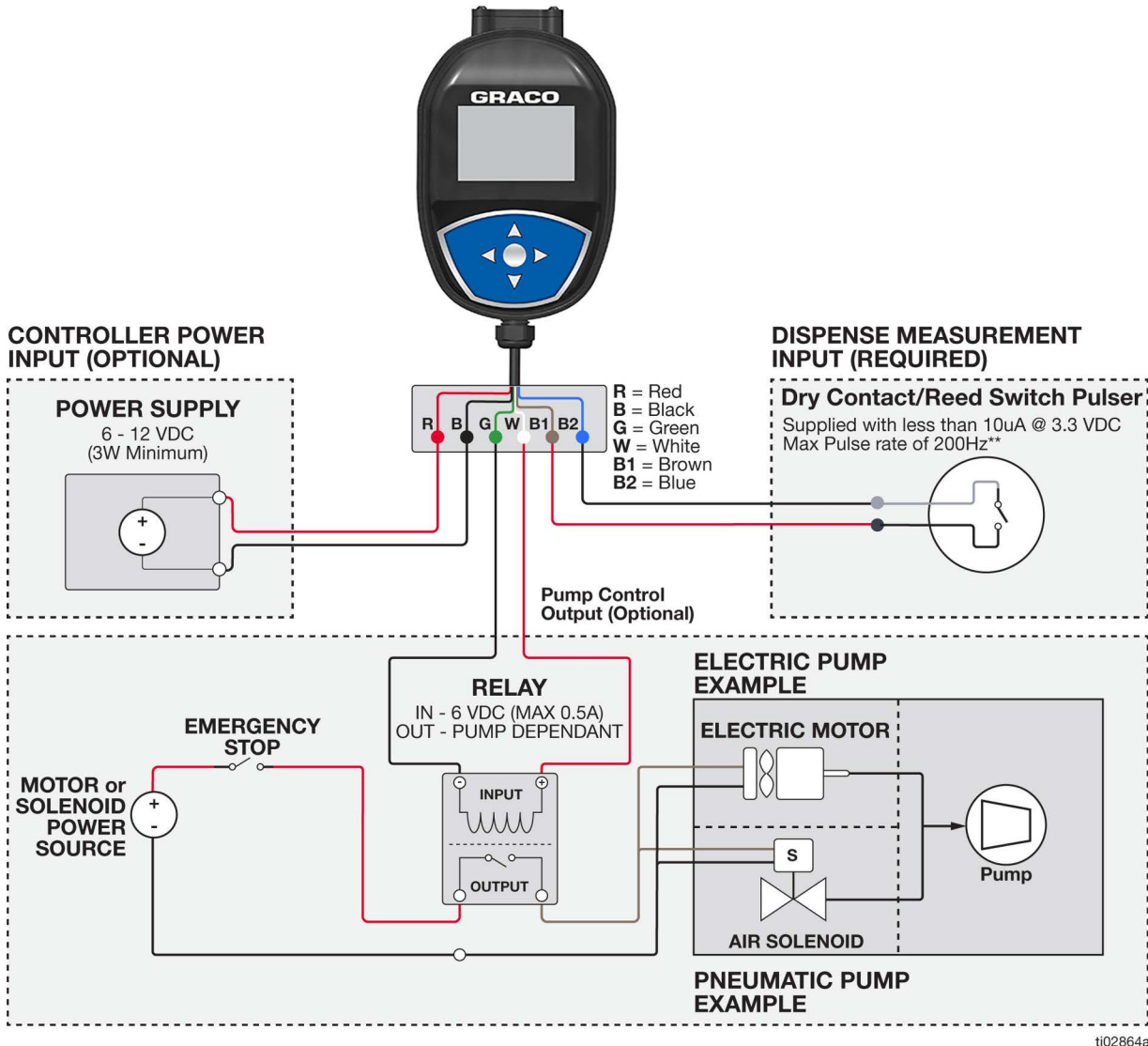

FIG. 7

Setup

Main Menu Screen

This screen provides access to the main dispense controller functions (FIG. 8):

These functions are described in the Operation section of the manual.

- DISPENSE
25V710, beginning on page 16
25V711, beginning on page 19
- SETUP, page 21
- SYNC (25V711 only), page 21
- UTILITY MENUS, page 22

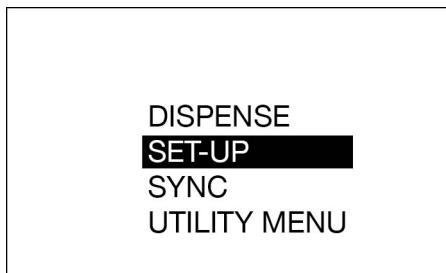

FIG. 8

REGISTER

The dispense controller must be registered with the Pulse Fluid Management Software before it can dispense fluid.

NOTICE

Meter firmware v1_04_007(or greater) requires Pulse Fluid Management Software to be updated to a minimum of v4.2.40.3. Meter firmware version can be viewed by opening the Device Information Screen as shown in FIG. 44.

1. Put the Pulse Fluid Management Software into DISCOVERY mode.

2. From the MAIN MENU screen, use the UP and DOWN arrow on the navigation pad to select the SET-UP option.

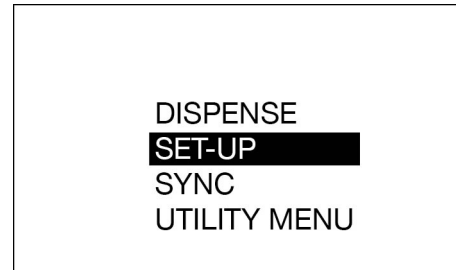
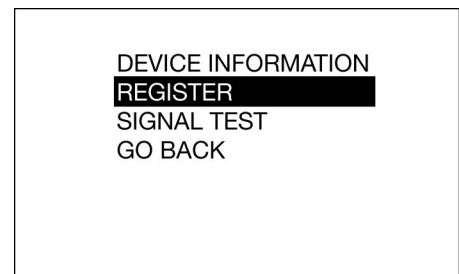

FIG. 9

3. From the SET-UP MENU, use the UP and DOWN arrow on the navigation pad to select the REGISTER option.



ti01237a

FIG. 10

4. Press the ENTER button.

REGISTERING appears in the middle of the display during registration, as shown in FIG. 11.

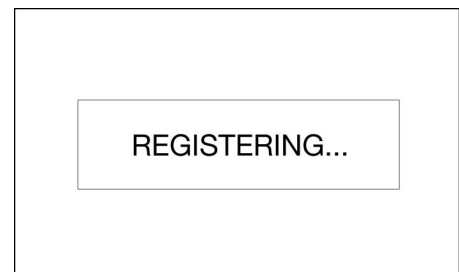

ti01238a

FIG. 11

- After the dispense controller has successfully registered with the Pulse Fluid Management Software, REGISTERED displays (FIG. 12). Then the SET-UP MENU screen displays.



FIG. 12

If the dispense controller does not register with the Pulse Fluid Management Software, FAILED appears on the display (FIG. 13).

NOTE: If the dispense controller fails to register with the Pulse Fluid Management Software, verify that the software is in DISCOVERY mode and retry registration.

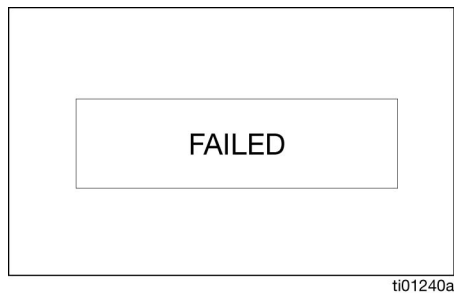

FIG. 13

Calibrate the Dispense Controller

NOTE: This calibration procedure requires one quart or one liter, calibrated, volumetric flask. When the controller is configured to display fluid volume in pints, quarts or gallons, the calibration procedure requires a one quart volumetric flask be used. When the controller is configured in liters, a one liter volumetric flask is required for calibration.

Calibrate the dispense controller prior to using it for the first time. Calibrating the dispense controller assures dispenses are accurate.

Calibration factors can vary due to the meter (pulsar) being used, as well as fluid viscosity and flow rate. Calibrate the dispense controllers for specific fluid at nominal flow rates.

- Ensure that the fluid system is fully primed and free of air bubbles.
- Select the UTILITY MENU option (FIG. 14).

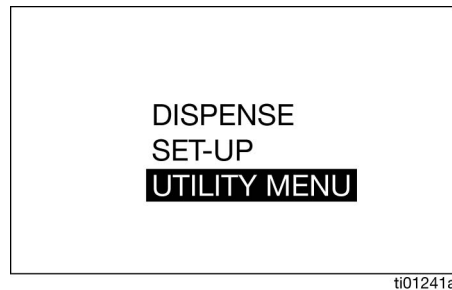

FIG. 14

- Enter the UTILITY MENU code.
- Select the CALIBRATE option to display the calibration K-Factor screen (FIG. 15 and FIG. 16).

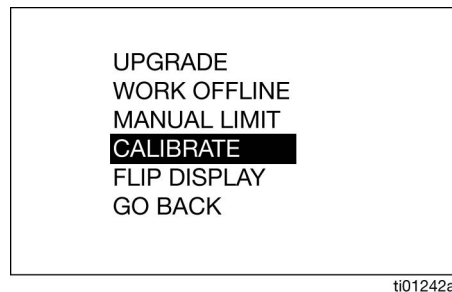

FIG. 15

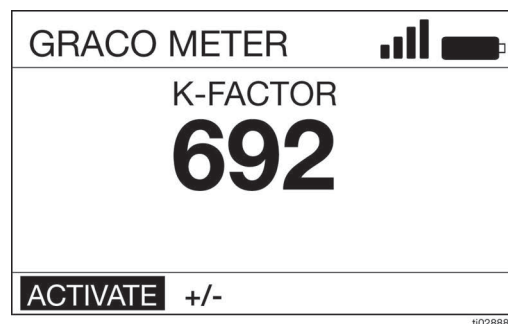
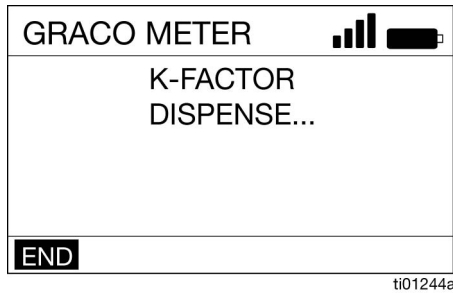

FIG. 16

5. Select ACTIVATE then press the ENTER button to begin dispense controller calibration (FIG. 16).
 6. Dispense exactly one quart or one liter of fluid into a clean, calibrated, volumetric flask.
- NOTE:** The dispense controller will not display the volume dispensed. The volume dispensed is only determined by the flask measurement.
7. When exactly one quart or one liter of fluid is dispensed into the flask, select END and press the ENTER button. The new calibration factor displays.
 8. Select END and press the ENTER button to complete the operation and save the new calibration factor.



ti01244a

FIG. 17

Alternate Calibration

NOTE: Use this alternate calibration procedure when a one quart or one liter, calibrated, volumetric flask is not available.

1. If the system is not fully primed, flush the dispense controller.
2. Dispense a known volume of liquid into a clean, calibrated, volumetric flask. Note this volume as the VOLUME DISPENSED (see Calculating K-Factor, Step 9, page 11).
3. Record the volume displayed on the dispense controller. Note this volume as the VOLUME DISPLAYED on the dispense controller (see Calculating K-Factor, Step 9, page 11).

4. Select the UTILITY MENU option (FIG. 18).



ti01241a

FIG. 18

5. Enter the UTILITY MENU code.
6. Select the CALIBRATE option (FIG. 19).

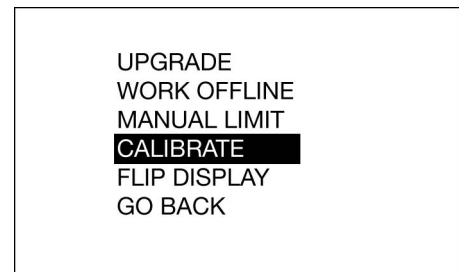

ti01242a

FIG. 19

7. Use the LEFT or RIGHT arrows to select +/- and press the ENTER button.

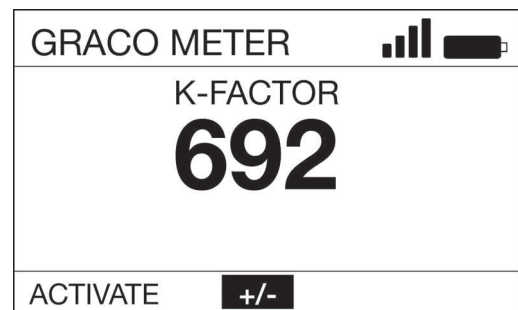

ti02899a

FIG. 20

8. The current K-FACTOR is displayed. In the example shown the K-FACTOR is 169 (FIG. 21).

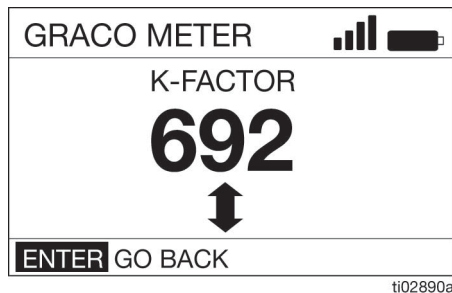

FIG. 21

9. Calculate the new K-Factor using the following equation:

$$K_{\text{new}} = \frac{(K_{\text{current}}) \times (\text{VOLUME DISPLAYED ON METER})}{(\text{VOLUME DISPENSED})}$$

Example:

$K_{\text{current}} = 692$

Volume displayed on dispense controller = 0.970 quart

Volume dispensed = 1 quart

$$K_{\text{new}} = \frac{(692) \times (0.970 \text{ quarts})}{(1.0 \text{ quarts})} = 671.2$$

Round to the nearest whole number: $671.2 = 671$.

NOTE: The unit of measurement for both volumes must be the same in the above equation,

10. Use the UP or DOWN arrows to adjust the K-Factor to the K-Factor (K_{new}) calculated in Step 9.
11. Press the ENTER button to complete the calibration operation and to save the new calibration factor.

NOTE: The K_FACTOR is displayed in units of pulses per gallon. See your meter/pulser manual for evaluating the accuracy of the calculated K_FACTOR.

Security Authorization

Utility Menu Codes

Utility Menu codes are set up by the System Administrator using the Pulse Fluid Management Software. Utility Menu Codes are assigned in the Device Settings Section of the Pulse Fluid Management Software.

Utility Menu codes are used for accessing items in the meter Utility Menu. The System Administrator can set up a unique code for each meter or the same code can be used for all meters in the system.

PIN Codes

Personal Identification Number (PIN) Codes are set up by the System Administrator using the Pulse Fluid Management Software. PIN Codes are assigned in the User Section of the Pulse Fluid Management Software.

A PIN Code is a numeric password used to authenticate a user in the system. User access is granted only when the PIN Code entered at the dispense controller matches the number stored in the Pulse Software.

To obtain dispense authorization, the user is required to scan an NFC fob or enter a 4-digit or 5-digit PIN Code before every new dispense.

Entering a PIN Code Number at the Dispense Controller

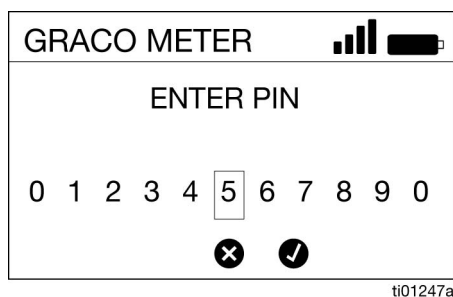

ti01247a

FIG. 22

1. Use the LEFT and RIGHT arrows to select the first PIN Code number field.
2. Press ENTER to select the number.
3. Continues this process until the 4- or 5-digit PIN Code is entered.
4. After the last number is entered, the cursor automatically moves to the ✓. Press ENTER to send the PIN Code entry to the Pulse Fluid Management Software.

The message VALIDATING appears on the display (FIG. 23).

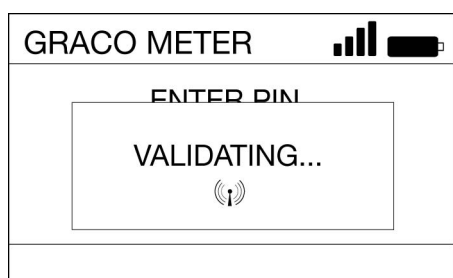

ti01248a

FIG. 23

If the Pulse Fluid Management Software recognizes the PIN Code and authorizes the dispense, a Dispense Screen displays.

If the Pulse Fluid Management Software does not recognize the PIN Code, the dispense controller will not authorize a dispense and INVALID displays.

Authorization Using an NFC FOB

When the dispense controller prompts for an NFC input as shown in FIG. 24, gently touch or tap the NFC fob in the reading zone located at the top of the bezel (FIG. 24).



ti02887a

FIG. 24

If the NFC fob is not recognized or validated, the dispense controller does not authorize the dispense and INVALID displays.

Operation

Dispense Menus

Manual Dispense Screens

Model 25V710 (only)

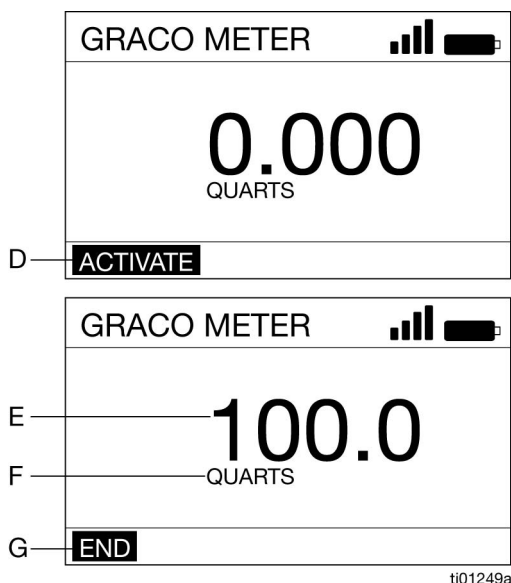

FIG. 25

- D ACTIVATE - activates the pump signal to dispense.
- E Volume of fluid dispensed - the number increases to reflect the quantity dispensed.
- F Unit of Measure (Imperial or Metric): The unit is set using the Pulse Fluid Management Software.
- G END - finalizes the dispense in the Pulse system.

Manual Dispense Mode

1. Press any button on the dispense controller key pad to wake the dispense controller (FIG. 1, page 6).
2. Press ENTER to select ACTIVATE (D).
3. Pull the trigger on the dispense valve to dispense fluid. DISPLAY (E) shows the amount dispensed.
4. Release the trigger to stop the fluid flow when the desired amount has been dispensed.
5. END (G) is highlighted on the screen, press ENTER to select END.

Preset Dispense Screens

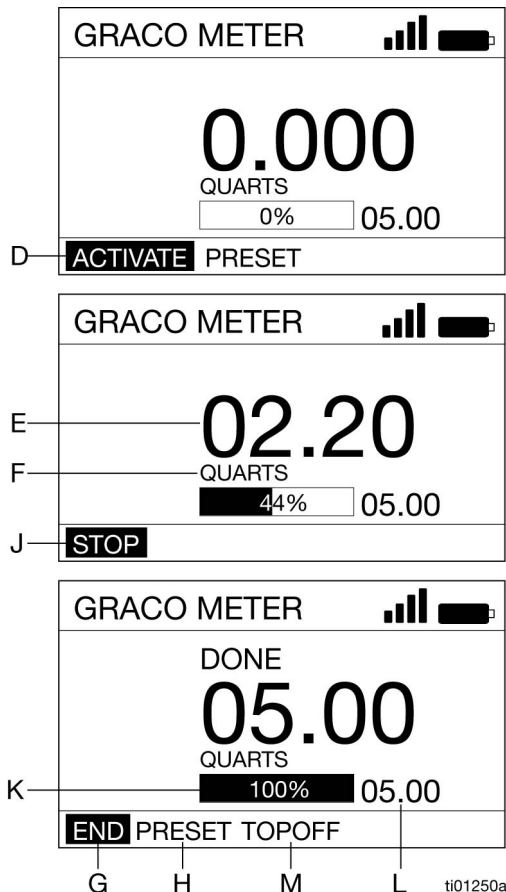

FIG. 26

- D ACTIVATE - activates the pump signal to dispense.
- E Volume of fluid dispensed - the number increases to reflect the quantity dispensed.
- F Unit of Measure (Imperial or Metric) - the unit is set using the Pulse Fluid Management Software.
- G END - finalizes the dispense in the Pulse system.
- H PRESET - navigates to the preset selection user menu so user can select from predefined preset values.
- J STOP - stops the preset dispense before it reaches the preset amount and deactivates the pump signal.
- K Progress Bar - a estimated visual display of the progress of the dispense. It includes the complete value.
- L Total Preset Amount - the amount of fluid to be dispensed when preset is complete.
- M TOPOFF - allows additional fluid dispense by the user after the present amount is reached.

Preset Dispense Mode

1. Press any button on the dispense controller key pad to wake the dispense controller (FIG. 1, page 6).
2. Enter the PIN or Work Order (if required by the dispense controller setup parameters).
3. Use the RIGHT ARROW to highlight PRESET (H) on the screen, and press ENTER to select (FIG. 27).

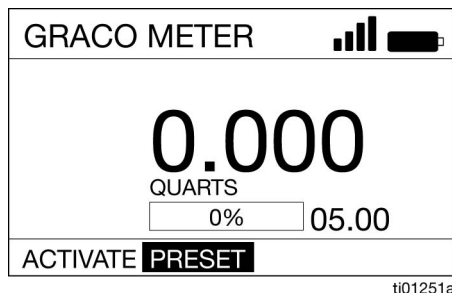

FIG. 27

4. Use the UP and DOWN ARROWS to toggle between the preset values. A maximum of five presets can be defined through the Pulse Fluid Management Software. When the desired preset value displays, press ENTER.
5. ACTIVATE (D) is highlighted on the screen, press ENTER to select ACTIVATE.
6. Pull the trigger on the dispense valve to dispense fluid. DISPLAY (E) shows the amount dispensed.

NOTE: To change the preset value or to stop the dispense before reaching the preset amount, release the trigger to stop the fluid flow. Use the RIGHT or LEFT ARROW to select STOP (J), and press ENTER.

Change Preset Before Dispense is Started

1. Highlight ACTIVATE (D) on the screen and press ENTER.

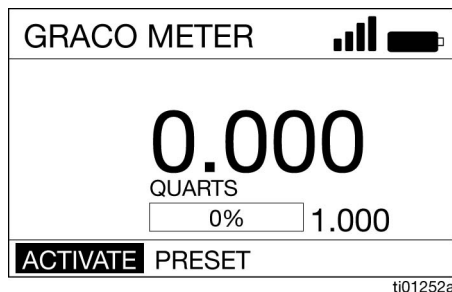

FIG. 28

2. Use the UP and DOWN ARROWS to change the preset value by increments of 0.1.
3. Pull the trigger to dispense the fluid.

Change Preset After Dispense is Started

1. Perform Steps 1 to 5 of the Preset Dispense procedure.
2. Pull the trigger to dispense fluid until a quantity less than the present amount is dispensed.
3. Use the RIGHT or LEFT ARROW to select STOP (J) and press ENTER (FIG. 29).

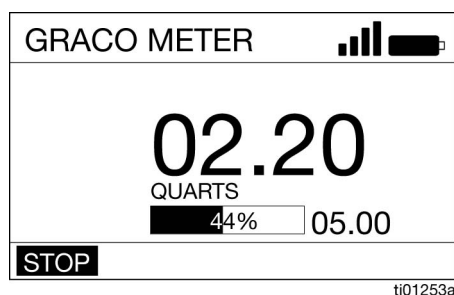

FIG. 29

4. Use the LEFT and RIGHT ARROWS to select PRESET (H) and press ENTER (FIG. 30).

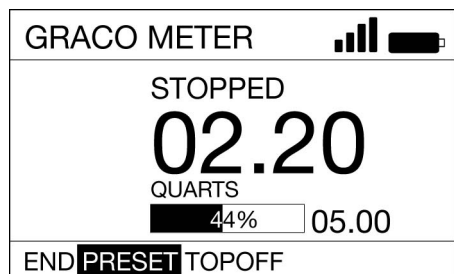
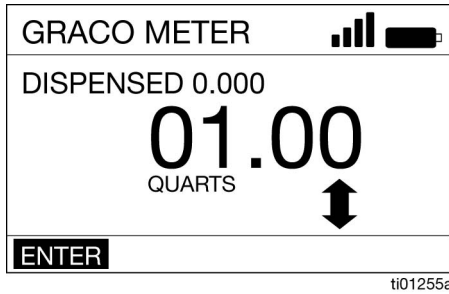

FIG. 30

5. Press the UP and DOWN ARROWS to toggle between up to five presets entered using the Pulse Fluid Management Software.



ti01255a

FIG. 31

6. Press ENTER when the desired preset value displays,
7. Use the RIGHT or LEFT ARROW to ACTIVATE (D) and press ENTER.
8. Pull the trigger to dispense the fluid.

Complete the Dispense

1. After the present amount has dispensed, the dispense controller stops dispensing.
2. Options:
 - TOPOFF (M) to add additional fluid. See **TOPOFF**, page 18.

NOTE: The amount of TOPOFF allowed is limited during dispense controller programming.

OR

- END (G) to finish the dispense, and press ENTER to select END.

TOPOFF

TOPOFF allows for adding additional fluid after the preset amount of fluid has dispensed. TOPOFF amounts are programmed in the Pulse Fluid Management Software.

1. Press ENTER to select TOPOFF on the display.
2. Pull the trigger on the dispense valve to dispense additional fluid. The amount dispensed will continue to count.
3. The TOPOFF ends when the trigger is released or when the maximum allowed TOPOFF value is reached. The cursor will be over STOP on the display.

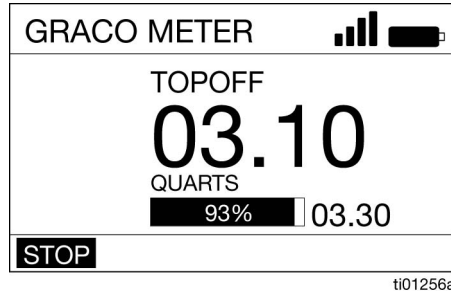

ti01256a

FIG. 32

4. Press ENTER.

Work Orders

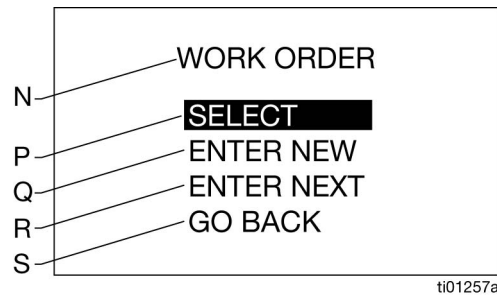

ti01257a

FIG. 33

- N WORK ORDER - title, identifies the screen as the WORK ORDER options screen (appears on English language version only).
- P SELECT - displays work order option available with work orders created using the Pulse Fluid Management Software.
- Q ENTER NEW - allows user to create a new work order on the dispense controller.
- R ENTER NEXT - displays the last work order in an editable format to allow the user to change part, or all, of the characters displayed to create a new work order.
- S GO BACK - displays the Main Menu Screen, see **Main Menu Screen**, page 11.

The System Administrator can program the dispense controller to process work orders using one, or both, of the following methods:

- Work Orders are created using the Pulse Fluid Management Software (SELECT (P)).
- Work Orders are created by the user on the dispense controller [ENTER NEW (Q) OR ENTER NEXT (R)].

Work Orders Created Using Pulse Fluid Management Software

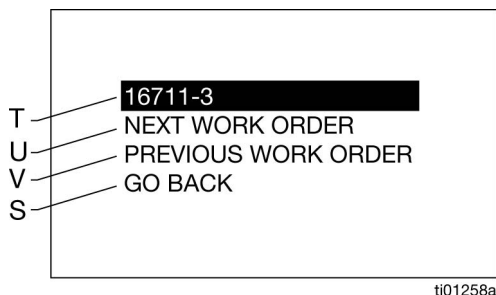

FIG. 34

- T Work Order Number - unique number assigned to a specific work order.
- U NEXT WORK ORDER - allows user to display the next work order in the queue.
- V PREVIOUS WORK ORDER - allows user to display the previous work order in the queue.
- W GO BACK - displays the Main Menu Screen, see **Main Menu Screen**, page 11.

Work Orders Created On The Dispense Controller

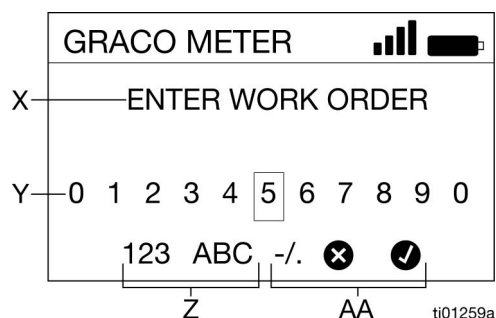

FIG. 35

- X ENTER WORK ORDER - title, identifies the screen as the Enter Work Orders options screen.
- Y Numbers/characters - available numbers and characters the user can enter to create the unique work order identification number.
- Z 123 ABC -./. - sets the character parameters used to create the unique work order identification number.
- AA X/✓ - X cancels the work order before entering it in the system. ✓ accepts the work order and enters it in the system.

Work Orders can have a maximum of twenty characters.

Enter a New Work Order at Dispense Controller

1. Use the arrows to position the cursor over a number or character to be selected.
2. Press Enter after each selection.
3. After the complete work order number is entered, select ✓, and press ENTER.
4. The DISPENSE screen displays.

Asset Dispense Screens

Model 25V711 (only)

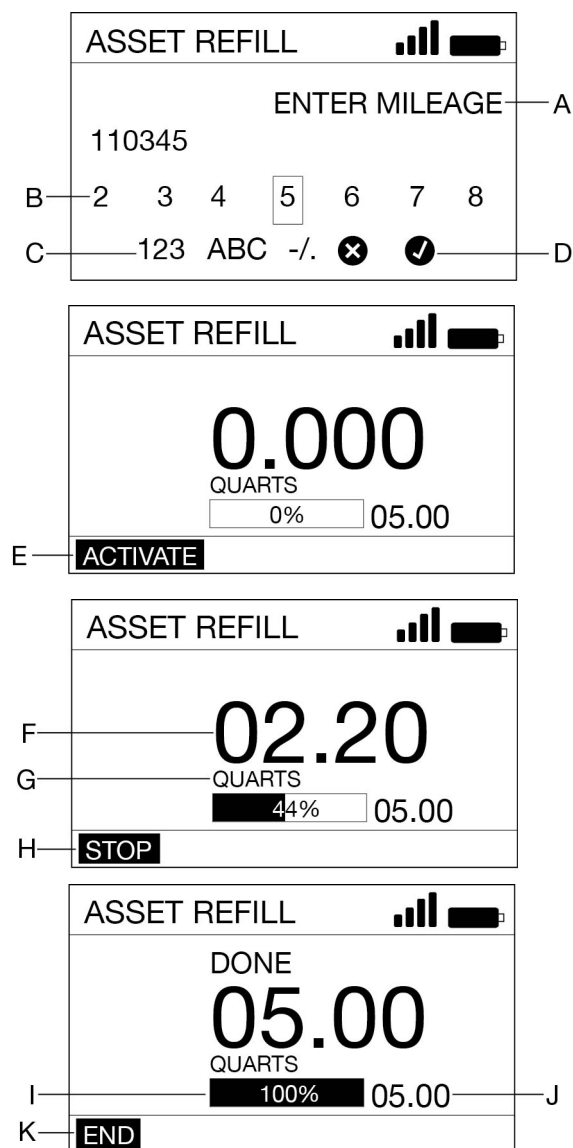

FIG. 36

Operation

- A Reference Prompt - asset specific reference data being requested.
- B Numbers/characters - available numbers and characters available (Maximum of seven characters) to store reference data.
- C 123 ABC - / . - sets the character parameters used to create reference data.
- D X/✓ - X cancels the dispense. ✓ saves the reference data and attaches it to the dispense record.
- E ACTIVATE - activates the pump signal for a dispense.
- F Volume of Fluid Dispensed - the number increases as fluid is dispensed, to reflect quantity of fluid dispensed.
- G Unit of Measure - set using the Pulse Fluid Management Software.
- H STOP - stops the preset dispense before it reaches the preset limit and deactivates the pump signal.
- J Total Present Limit - amount of fluid that can be dispensed before the controller deactivates.
- K END - Finalized the dispense and stores to the controller memory.

Dispense Fluid to An Asset

1. Press any button on the navigation pad to wake the dispense controller (see FIG. 1, page 6).
2. Use the UP and DOWN ARROWS on the navigation pad to select DISPENSE and then press ENTER.
3. Scan the user identification tag (NFC fob) (FIG. 37).

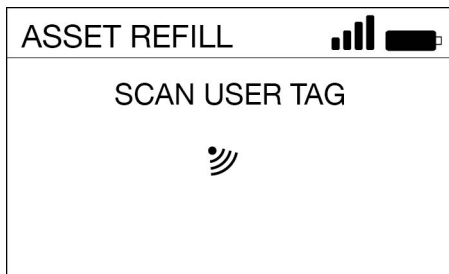

FIG. 37

4. Scan the asset identification tag (NFC fob) (FIG. 38).



FIG. 38

5. If the asset is configured to require reference data enter the data using the keypad (FIG. 39).

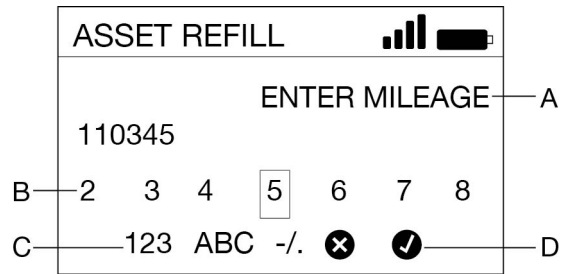

FIG. 39

6. Press ENTER to select ACTIVATE (FIG. 40).

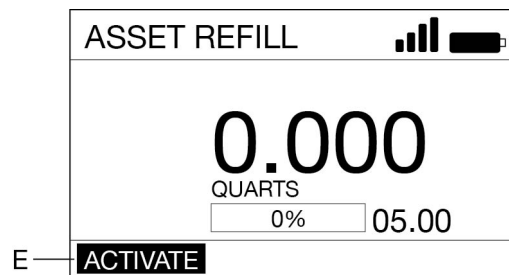

FIG. 40

7. Pull the trigger to dispense. The display shows the amount dispensed (F) (FIG. 41).

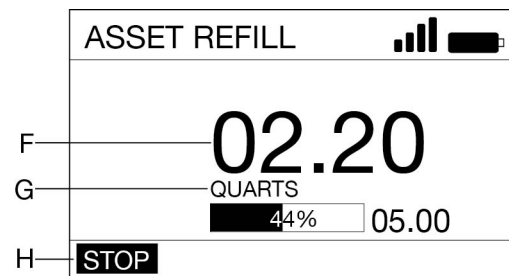

FIG. 41

8. Release the trigger to stop fluid flow when the desired amount is dispensed.
9. END (K) highlights on the screen, press ENTER to select (FIG. 42).

Setup Menus

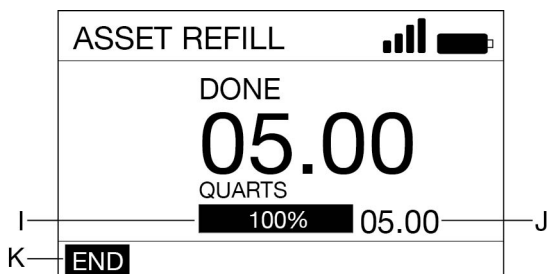

FIG. 42

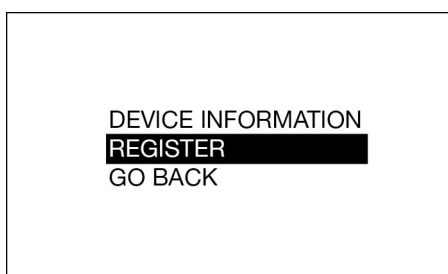

FIG. 43

Device Information

The Device Information screen is used for diagnostics only (FIG. 44)

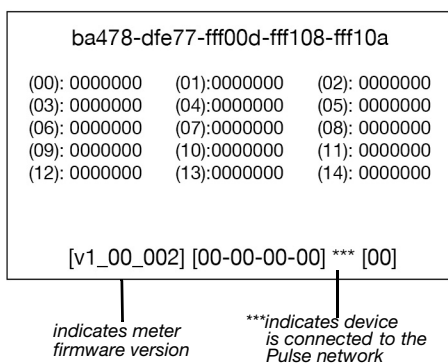

FIG. 44

REGISTER

See REGISTER, page 11.

GO BACK

Goes back to the Main Menu Screen, **Main Menu Screen**, page 11.

Sync Menus - Model 25V711 Only

The dispense controller needs to be synced with the Pulse Pro System after reaching maximum dispense storage queue size or maximum synchronization duration.

1. Press any button on the navigation pad to wake the dispense controller (see FIG. 1, page 6).
2. Use the UP and DOWN ARROWS on the navigation pad to select SYNC on the screen, then press ENTER.
3. The controller will begin to sync (FIG. 45).

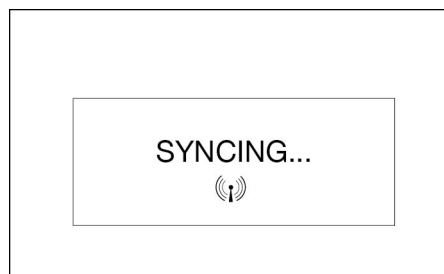

FIG. 45

4. The controller displays SYNCED if successful, or FAILED if unsuccessful (FIG. 46 and FIG. 47)

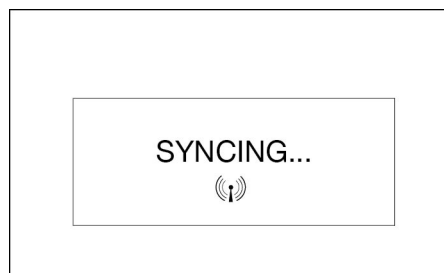

FIG. 46



FIG. 47

Utility Menus

- The Utility Menu is PIN or NFC Code protected. The Utility Menu code must be entered to activate the menu (FIG. 48).

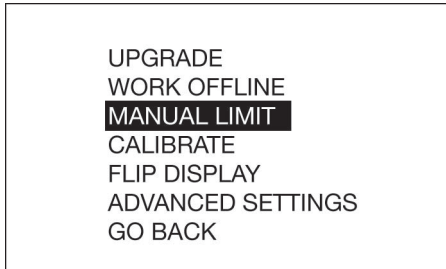

FIG. 48

UPGRADE

Modifies the firmware used by the dispense controller when a new or upgraded version of the firmware is released, or when a new feature is added. Upgrade instructions are provided by your Graco distributor.

WORK OFFLINE

If the communication link between the dispense controller and the Pulse HUB is disrupted, the dispense controller functions if placed into WORK OFFLINE.

When the dispense controller is in WORK OFFLINE, no asset tracking or verification takes place.

When communication is reestablished, the dispense controller automatically changes to online operation.

CALIBRATE

Calibration of the dispense controller assures dispenses are accurate. See **Calibrate the Dispense Controller**, page 12.

MANUAL LIMIT

The maximum amount of fluid a user can dispense while the dispense controller is in MANUAL or WORK OFFLINE.

FLIP DISPLAY

Flips the dispense controller display upside down to accommodate viewing data for oil bar installation.

ADVANCED SETTINGS

- Allows for manual control of the advanced controller settings. Modifications should only be done when instructed by your Graco distributor or Graco Technical Assistance.

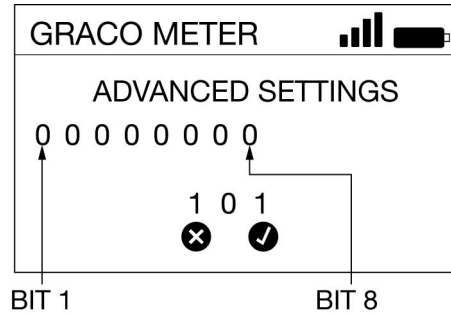

FIG. 49

Bit 1: Disassociate meter from Pulse PAN.

0) Default value - controller retains association with current Pulse PAN.

1) Enable reset - if set to 1, and the ADVANCED SETTING mode is saved and exited, when the controller falls asleep, it disassociates from the active Pulse PAN. To return to service, the controller needs to be re-discovered.

Bit 2: Disable unauthorized dispense check.

0) Unauthorized dispense check enabled - controller monitors for unauthorized flow.

1) Unauthorized dispense check disabled - controller does not monitor for unauthorized flow.

Bit 3: Disable secondary reed switch check.

0) Reed switch check enabled - controller monitors both reed switches for fault detection.

1) Reed switch check disabled - controller only monitors primary reed switch. There is no fault detection.

Bit 4 - 6: Not used.

Bit 7: Strict Dispense Reporting (25V710 only).

0) Default value - disabled. Work order dispenses that fail to report, get committed to offline totalizer upon failure to report.

1) Enabled - a new dispense cannot start on the unit until the previous dispense record is reported.

Bit 8: Battery Saver Mode (25V710 only).

0) High power mode - RF radio remains powered during the dispense to improve connectivity. Dispense reporting window increases from 30 seconds to 10 minutes.

1) Default value - battery saver enabled.

GO BACK

Goes back to the Main Menu screen, **Main Menu Screen**, page 11.

Recycling and Disposal

This section includes information on how to properly recycle and dispose of a product at the end of its useful life.

End of Product Life

At the end of the product's useful life, dismantle and recycle it in a responsible manner.

- Remove motors, batteries, circuit boards, LCDs (liquid crystal displays), and other electronic components. Recycle according to applicable regulations.
- Do not dispose of batteries or electronic components with household or commercial waste.



- Deliver remaining product to a recycling facility.

Troubleshooting



Perform pressure relief procedure for your pump, before checking or repairing the dispense controller. Be sure that all other valves, controls, and pumps are operating properly.

Problem	Cause	Solution
Battery dead icon is present.	Batteries are low.	Replace batteries*, page 29.
Display does not activate	Batteries are dead.	Replace batteries*, page 29.
	External power supply is not providing power to the dispense controller.	Confirm that the external power supply is connected and functional. Replace if necessary.
	Electronic control is malfunctioning.	Replace the dispense controller.
Displayed dispensed amount does not increment when a dispense is made, even though fluid is flowing.	Dispense is not active.	Put the dispense controller into an active dispense state. The screen displays END in the bottom left corner when a dispense is active.
	Meter (pulser) not wired properly	Review Installation , page 9, and Wiring , page 9. Controller functionality can be confirmed (when disconnected from the pulser) by momentarily connecting the blue wire and brown wire together. This causes the dispense amount to increment.
	Meter (pulser) is not compatible with the Universal Controller	Contact your Graco distributor for help in selecting a compatible metering unit.
Displayed dispense amount is not accurate.	Controller needs to be calibrated for the fluid/meter being dispensed.	Calibrate the dispense controller.
Weak or no RF signal	Changes/obstructions in RF pathway (i.e., vehicle, overhead door)	Add Graco Extender to Pulse System. Order Graco Part No. 20A058- US/Canada; 20A059 - EU; 20A151 - UK; 20A152 - ANZ.
Controller registration fails	Poor RF signal	See Troubleshooting, Weak or no RF Signal
	Pulse Fluid Management Software is not in Discovery Mode.	Set software to Discover Mode, then retry registration.
Screen locks up or freezes	System detects unauthorized flow (dispense pulses).	Wait 60 seconds after pulses are complete for the interface to become available again. See Advanced Settings menu for option to disable unauthorized dispense check.
	General fault.	Remove batteries or disconnect the power supply. Wait 15 minutes, then repower and restart.

Problem	Cause	Solution
Pump does not turn on or off with dispense status change.	Pump control circuit is not wired properly.	Review Installation , page 9, and Wiring , page 9. Controller functionality can be confirmed by measuring the voltage across the green and white output wires. A nominal 6 V should be present when a dispense is active.
	Pump control is drawing too much current.	End the dispense and check the wiring for short circuits. Wait 15 min. for the thermal fuse to reset. If the issue persists, investigate further.
*Power the controller using an external power supply, if possible.		

Fault Codes

Fault codes are listed below. Even in a fault condition the unit keeps track of the amount dispensed. Whenever a fault code is displayed, you must end the dispense.

Fault Code	Cause	Solution
Fault 2	Device misconfiguration.	Ensure that secondary reed switch check is disabled under Advanced Settings.
Fault 4	Flow continues after it should have shut off.	End dispense. Confirm flow is being disabled.
Fault 5	Manual limit reached on a dispense.	Adjust the manual limit higher, if desired. See Utility Menus , page 22 section for further details.
Fault 6	Zero-value preset in attempted dispense.	Internal fault. Contact your Graco distributor.

Definition of Terms

Terms	Definition
CALIBRATE	UTILITY MENU option. Calibrating the dispense controller ensures dispenses are accurate.
DEVICE INFORMATION	UTILITY MENU option. Used by System Administrator for diagnostics and set up.
DISCOVERY MODE	Mode of Pulse Fluid Management software that allows new devices to be registered.
DISPENSE	(Depending on how the dispense controller is configured) Selecting DISPENSE displays either the DISPENSE Screen, PIN Entry Screen or WORK ORDER MENU Screen.
FLIP DISPLAY	UTILITY Menu option. Allows user to view data on the display upside down.
GO BACK	Returns the user to the previous screen.
HUB	The Pulse HUB is a self-contained computer with the Pulse Fluid Management Software preloaded. It also is the Personal Area Network (PAN) host used for RF communication with other Pulse system components (meters, Pump Air Control [PAC's], Tank Level Monitors [TLM's]). Access to the Pulse Fluid Management system is accomplished by http protocol (web browser on the Local Area Network [LAN]).
MANUAL DISPENSE	Amount of fluid dispensed is determined by the operator
MANUAL LIMIT	UTILITY MENU option. The maximum amount of fluid a user can dispense while the dispense controller is in MANUAL MODE or WORK OFFLINE MODE.
NFC CODE	Alpha-numeric code present on the NFC fob. Used to authenticate a user to the system.
PIN CODE	A numeric password used to authenticate a user to the system.
PRESET DISPENSE	The dispense controller is programmed to dispense a default, preset volume. The preset volume can be modified on a work order to work order basis when sending work orders from the Pulse Fluid Management Software. The preset volume can be increased or decreased by an amount at the dispense controller prior to beginning the dispense.
REGISTER	Similar to pairing. Allows the Pulse HUB to identify and communicate with individual Pulse devices.
SET UP	List of dispense controller function related to initial system set up, device information, registration and signal testing.
SYSTEM ADMINISTRATOR	A user defined in the Pulse Fluid Management system software with full administrative authority.
TOPOFF	A percentage of the preset volume that can be (at the operator's discretion) dispensed after the preset amount has been reached.
UPGRADE	UTILITY MENU option. Modifies the firmware software used by the dispense controller when a new and upgraded version of the software is released or a new feature is added. When this is required, your Graco distributor will contact you to arrange the upgrade.
UTILITY MENU	List of dispense controller functions: UPGRADE, WORK OFFLINE, MANUAL LIMIT, CALIBRATE, FLIP DISPLAY, GO BACK.
UTILITY MENU CODE	Utility Menu Codes are used to access items in the meter utility menu. Can be a PIN or NFC Code.
WORK OFFLINE	UTILITY MENU option. If the communication link between the dispense controller and the Pulse Fluid Management Software is lost due to power loss or the computer crashing, the dispense controller will continue to function if it is placed in WORK OFFLINE Mode.
WORK ORDER	A unique (within the scope of the dealership) numeric or alphanumeric identifier that is linked to a list of labor and parts charges representing the expenses associated with a specific customer's vehicle repair. Also referred to as a repair order, or RO. The work order can be used more than once (it does not have to be unique).

Repair

Battery Replacement

- Replace batteries with four AA, alkaline batteries.
 - Follow the polarity (FIG. 50).
 - Replace all four batteries with four, fresh, new AA batteries. Do not mix different brands of batteries together or old batteries with fresh.
1. Remove screws (36) from the battery compartment cover (5).
 2. Use a small, flat screwdriver to gently pry the cover away from the dispense controller housing (FIG. 50).

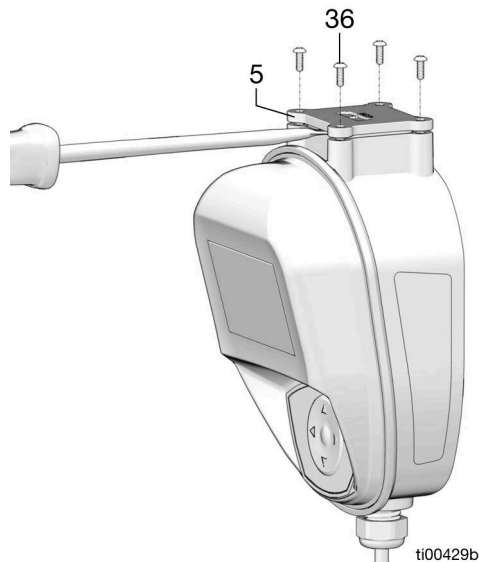

FIG. 50

3. Remove and recycle batteries according to all applicable local codes and regulations.

4. Install four new batteries (FIG. 51).

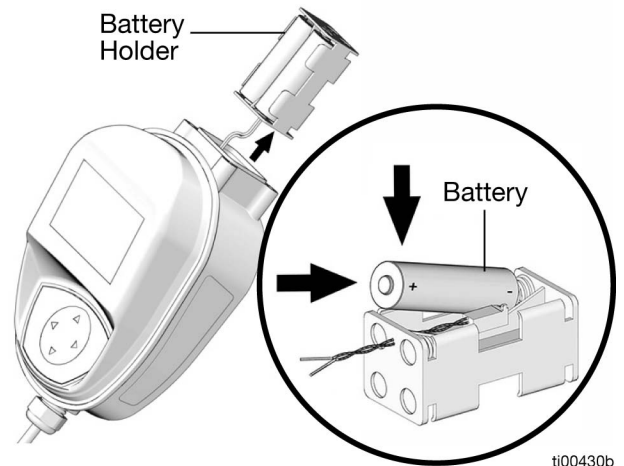

FIG. 51

5. Replace cover (5) and screws (36). Do not tighten fasteners with torque greater than 10 in.-lb (1.1 N•m). If replacement screws are needed, they can be sourced as #4-40 x 5/16 in. fasteners.

Dimensions

Mounting Pattern

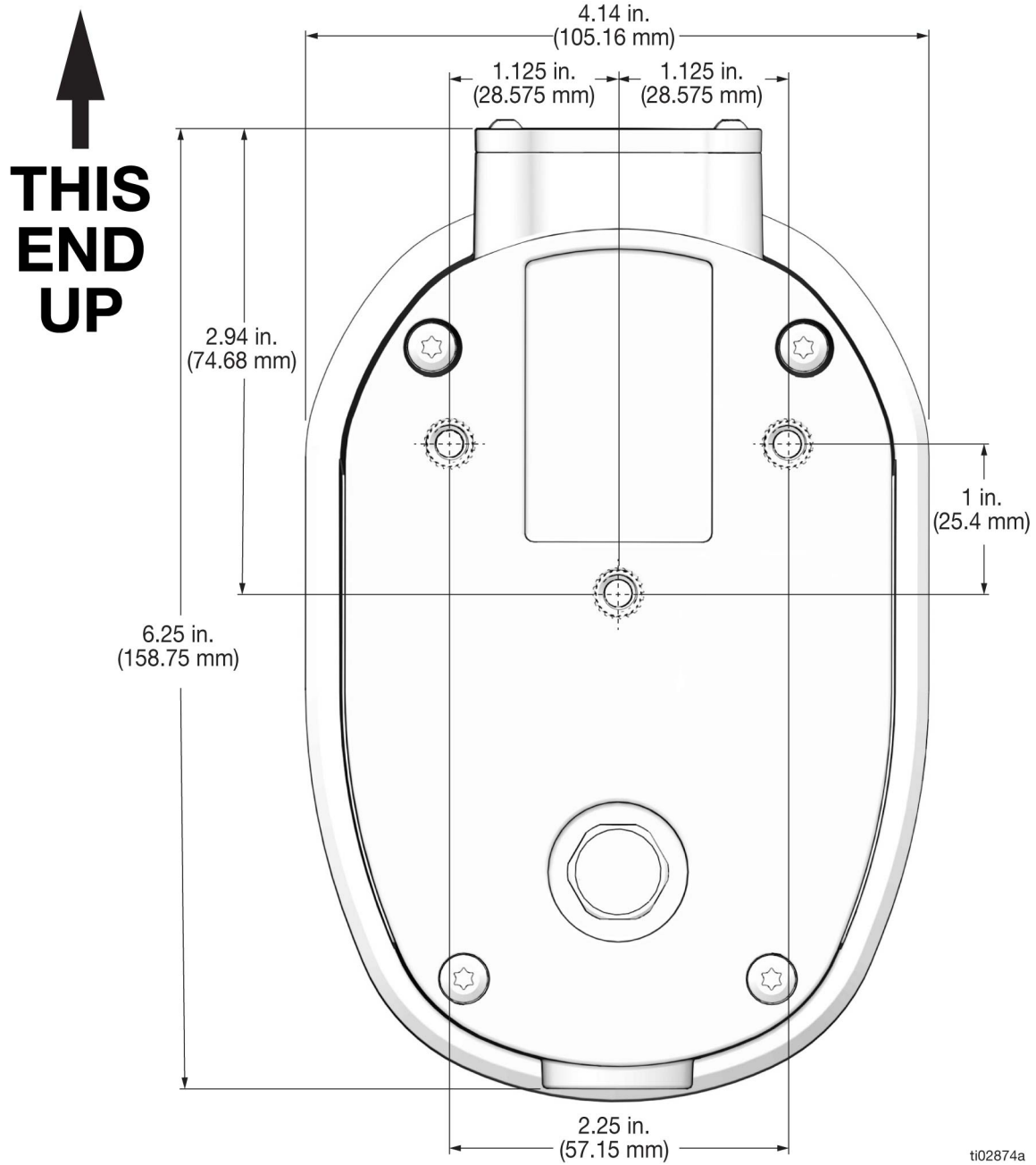

FIG. 52

Technical Specifications

Dispense Controller	US	Metric
Unit of Measure (factory set to quarts)	pints, quarts, gallons	liters
Weight	1.5 lb	0.7 kg
Dimensions		
Length	7 in.	18 cm
Width	4.00 in.	10.1 cm
Height	3.75 in.	9.5 cm
Input/Output Cable		
Length	4 ft	1.2 m
Cable Outer Diameter	0.22 in.	5.6 mm
Internal Conductor Size	22 AWG	
Power Supply Input		
Voltage	6 to 12 VDC	
Power	3 W	
Pump Active Signal Input		
Voltage	6 VDC (Nominal)	
Power	3 W (Maximum)	
Meter/Pulser Signal Input		
Pulser Type	Passive, 2-wire, dry reed switch (supplied with less than 10uA at 3.3 VDC)	
Maximum Line Length (22 gauge) to Pulser	100 ft	30 m
Units of measure (factory set in quarts)	maximum recorded dispensed volume = 9999 units maximum preset volume = 9999 units	
Operating temperature range	4 °F to 158°F	-16°C to 70°C
Storage temperature range	-40°F to 158°F	-40°C to 70°C
Battery**	4AA alkaline batteries	
**Recommended battery: Energizer® Alkaline E91.		
RF Frequency Band	2400-2483.5 MHz	
Maximum RF Transmit Power	6.3 mW (8 dBm)	
NFC Frequency Band	13.56 MHz	
Maximum NFC Transmit Power	1 mW (0 dBm)	
Mounting	1/4 - 20 x 1/2 in. thread inserts (x3)	
Intrusion Rating	IP69K	
Vibration Test Standard	MIL-STD-810-Category 4	
<i>All trademarks or registered trademarks are the property of their respective owners.</i>		

California Proposition 65

CALIFORNIA RESIDENTS

 **WARNING:** Cancer and reproductive harm – www.P65warnings.ca.gov.

Graco Standard Warranty

Graco warrants all equipment referenced in this document which is manufactured by Graco and bearing its name to be free from defects in material and workmanship on the date of sale to the original purchaser for use. With the exception of any special, extended, or limited warranty published by Graco, Graco will, for a period of twelve months from the date of sale, repair or replace any part of the equipment determined by Graco to be defective. This warranty applies only when the equipment is installed, operated and maintained in accordance with Graco's written recommendations.

This warranty does not cover, and Graco shall not be liable for general wear and tear, or any malfunction, damage or wear caused by faulty installation, misapplication, abrasion, corrosion, inadequate or improper maintenance, negligence, accident, tampering, or substitution of non-Graco component parts. Nor shall Graco be liable for malfunction, damage or wear caused by the incompatibility of Graco equipment with structures, accessories, equipment or materials not supplied by Graco, or the improper design, manufacture, installation, operation or maintenance of structures, accessories, equipment or materials not supplied by Graco.

This warranty is conditioned upon the prepaid return of the equipment claimed to be defective to an authorized Graco distributor for verification of the claimed defect. If the claimed defect is verified, Graco will repair or replace free of charge any defective parts. The equipment will be returned to the original purchaser transportation prepaid. If inspection of the equipment does not disclose any defect in material or workmanship, repairs will be made at a reasonable charge, which charges may include the costs of parts, labor, and transportation.

THIS WARRANTY IS EXCLUSIVE, AND IS IN LIEU OF ANY OTHER WARRANTIES, EXPRESS OR IMPLIED, INCLUDING BUT NOT LIMITED TO WARRANTY OF MERCHANTABILITY OR WARRANTY OF FITNESS FOR A PARTICULAR PURPOSE.

Graco's sole obligation and buyer's sole remedy for any breach of warranty shall be as set forth above. The buyer agrees that no other remedy (including, but not limited to, incidental or consequential damages for lost profits, lost sales, injury to person or property, or any other incidental or consequential loss) shall be available. Any action for breach of warranty must be brought within two (2) years of the date of sale.

GRACO MAKES NO WARRANTY, AND DISCLAIMS ALL IMPLIED WARRANTIES OF MERCHANTABILITY AND FITNESS FOR A PARTICULAR PURPOSE, IN CONNECTION WITH ACCESSORIES, EQUIPMENT, MATERIALS OR COMPONENTS SOLD BUT NOT MANUFACTURED BY GRACO. These items sold, but not manufactured by Graco (such as electric motors, switches, hose, etc.), are subject to the warranty, if any, of their manufacturer. Graco will provide purchaser with reasonable assistance in making any claim for breach of these warranties.

In no event will Graco be liable for indirect, incidental, special or consequential damages resulting from Graco supplying equipment hereunder, or the furnishing, performance, or use of any products or other goods sold hereto, whether due to a breach of contract, breach of warranty, the negligence of Graco, or otherwise.

FOR GRACO CANADA CUSTOMERS

The Parties acknowledge that they have required that the present document, as well as all documents, notices and legal proceedings entered into, given or instituted pursuant hereto or relating directly or indirectly hereto, be drawn up in English. Les parties reconnaissent avoir convenu que la rédaction du présente document sera en Anglais, ainsi que tous documents, avis et procédures judiciaires exécutés, donnés ou intentés, à la suite de ou en rapport, directement ou indirectement, avec les procédures concernées.