

Safety Procedures

WARNING

Dangerous environment. Highly flammable/explosive fuels and high voltage are present. Failure to observe all safety precautions could result in serious injury or death. Observe all safety precautions as outlined in Gasboy® manuals.

Installation Procedures

1. Install a single EMERGENCY POWER CUTOFF control to remove AC power from site dispensing equipment. [The control is an additional safety feature, and not a substitute for National Electrical Code (NEC®)/National Fire Protection Association (NFPA) 30 circuit breaker requirements]. Label the EMERGENCY POWER CUTOFF switch and instruct owner to keep area clear of obstacles.

IMPORTANT INFORMATION

Devices such as Distribution Boxes (D-Boxes), two-wire, and so on, must be de-energized or have wiring disconnected from the dispenser by the emergency stop or equivalent mechanism. Third-party devices such as those supplying power or any form of communication to a dispenser (intercoms, third-party controllers, and so on) must also be de-energized or the wiring supplying that power be disconnected when activating the emergency power cutoff control or equivalent mechanism. Provision to accommodate this must not introduce noise [Radio Frequency Identifier (RFI) or electrical] into sensitive pump/dispenser electronic field wiring circuits during normal pump/dispenser operation. De-energizing of the external equipment through the emergency stop or equivalent device is recommended.

2. Connect an insulated grounding conductor from the dispenser power panel to the site grounding electrode (size per NEC).
3. Install power breakers to each circuit leading to each dispensing unit and to each Submersible Turbine Pump (STP). It must be capable of simultaneously disconnecting hot and neutral conductors. Gasboy requires the Dispenser breaker rating to be ≤ 15 A. *Note: In Canada, switching neutral is contrary to the Canadian Electrical Code (CEC), reference part 1, rule 14-014.*
4. Only field wiring connections are shown in the Junction boxes (J-boxes). Cap all unused wires. Local and NEC may apply.
5. Install conduit per NEC for hazardous locations. Potting is required for conduit that passes through any portion of a hazardous vapor area to ensure vapor barrier integrity. Wires - All wires are 14 American Wire Gauge [AWG (copper stranded)] unless otherwise noted. Dispenser ground wire is 12 AWG (copper stranded). Power loading and distance run may require larger wire size. Wire all circuits NEC Class 1, except wiring to speaker (intercom) and call button, which must be NEC Class 2. Gasboy two-wire is NEC Class 1 and may share the main power conduit. Diesel Exhaust Fluid (DEF) is a non-flammable fluid and does not generate explosive vapors. Generally wiring as related to DEF dispensers need not comply with requirements for hazardous locations (electrical safety requirements still apply) unless the unit is installed in a Class 1 Division 2 area of another pump/dispenser handling hazardous flammable or explosive fuels. Refer to the hazardous location drawing for the equipment involved. Generally for Gasboy equipment handling hazardous fuels, the hazardous location extends 20 feet from the base of the unit to a height of 18 inches from the forecourt and island. Consider future installation of equipment handling hazardous fuels that may be located near the DEF dispenser.
6. Two-wire communication wiring: For installations with “new” wiring, use Unshielded Twisted Pair (UTP) data wires. Wiring Spec: 10-12 twists per foot, 18 AWG up to 1000-foot runs (2000 feet total) or 14 AWG up to 2600 foot runs (5200 feet total) unshielded, 300 V minimum, stranded annealed copper tinned wire, Polyvinyl Chloride (PVC) insulation of type TFFN, THHN, or MTW, Underwriters’ Laboratories (UL®) approved gasoline and oil-resistant. Reference C&M Corporation Part #27525 (18 AWG) or equivalent. Refer to *MDE-5693 AtlasX Fuel Systems Site Preparation Manual* requirements where 14 AWG may be required.

- 6a. In Canada, installing communication circuits, such as data cables and AC cables in the same conduit as AC circuits is contrary to the Canadian Electrical Code (CEC) rule 60. New installations must have separate conduit for data/communication cables and power cables in the following circumstances (wiring for two-wire, data, communications, intercom, video, Ethernet®, Gilbarco Long Range Ethernet (GLRE), must be in a separate conduit from the dispensers power and light conduit):
 - All new installations of fuel dispensers or other electrical equipment, whether or not the raceways are exposed and made readily accessible as part of the installation process. OR
 - In any event if the raceways are exposed and made readily accessible for any reason.

7. Consult manufacturer specifications for wire nuts to determine maximum number of wires that may be used per nut.
8. STP isolation relay boxes are required by NEC 514-6 to:
 - a. Allow service of one unit safely without removing power from all dispensing equipment.
 - b. Prevent damage to equipment from cross-phasing. Damage caused by cross-phasing is not covered by warranty. (Use local supplier for isolation relay boxes).
9. Do not provide service loops or leave excess wire in electronics cabinet. Cut all wire lengths to size sufficient to reach termination without stress or excess. Dress all wires neatly along surfaces so as not to obstruct access to terminations and devices.
10. To avoid damage to any PC Boards, all unused wires must be individually capped. Before applying power, you must verify that the reset is complete, fast flow, submersible starter drive wires are not shorted to conduit or chassis.

11. Submersible starter drive (STP Control) line can supply 300 mA AC maximum to control submersible starter relays. This line must not be directly connected to a STP.
12. When using remote dispensers, external STP relays are required unless the remote dispenser is equipped with the submersible drive relay option. The submersible drive relay option provides a STP drive line (MTR1/2-Hot), which can directly drive a STP up to 3/4 HP at 115 VAC or 1-1/2 HP at 230 VAC. Any pump over these ratings will require a submersible starter relay. The 14 gauge MTR1/2-Feed and MTR1/2-Hot wires are always present. Verify that the submersible drive relay option is installed prior to wiring. The power supplied to the MTR1/2-Feed must be able to handle the load of the STP.

13. Reset complete (switch detect/Main Valve) line can supply 170 mA AC maximum for connecting to Fuel Management System (FMS) circuitry and in applications where control of a remote slow flow valve (satellite) is required.
14. Fast flow (Slow Down Valve) line can supply 170 mA AC maximum is provided to allow for control of a satellite along with remote control or monitoring of the fast flow valve found in the pump.

15. If the AUTH (control/pump motor feed) line is controlled by a FMS using solid state relays, a resistor assembly must be installed between the control feed line and feed neutral to prevent false triggering of the authorization input. The resistor assembly is 8.2 k Ohm, 10 Watt (P/N C05818) for 115/230 VAC domestic and 30 k Ohm, 10 Watt (P/N C06683) for 230 VAC international wiring.
16. When used with an aboveground tank, the valve mounted at the tank MUST NOT be connected to the reset complete or submersible starter drive lines. If the optional internal relay kit is installed and the valve's current draw will not exceed 1 A, the valve can be connected to the STP drive line. Otherwise, it should be driven from the external submersible starter relay. In all cases, the tank valve must operate at the same voltage as the STP.
17. When multiple dispensers are used to control a common submersible starter relay or pump, and the AtlasX® unit is controlled (authorized) through the AUTH (control/motor feed) line (as in the case of some FMS), it is important that the lines from the AtlasX unit to the submersible equipment be isolated from each other. This can be accomplished by running the submersible control lines through a secondary set of relay contacts in the FMS. If a secondary set of contacts is not available, external control relays must be used between the AtlasX unit and the submersible starter relay or pump. Another option is to provide a separate submersible starter relay for each hose outlet. In no case can the submersible drive lines from the AtlasX unit be tied together.

18. Valve is optional on Mechanical and Commercial pumps - 1 Grade, 1 Hose or 2 Grade, 2 Hose.

19. If combining a remote dispenser with a FMS, the maximum HP limitation for directly driving a remote dispenser without the use of an additional relay of submersible starter must be the lower of the two components.

20. Internal wiring that is not field terminated may be white in color.

21. Wires labeled with two colors signify that the first color is the color of the wire and the second is that of the stripe. For example, BLU/WHT would indicate a blue wire with a white stripe.

22. The Satellite Lamp (Indicator) inputs must not exceed 120 VAC.

23. For US 240 VAC installations, wires labeled FEED must be connected to L1 and wires labeled NEUTRAL must be connected to L2.

Electrical Rating

Control Valves 0.2 A @ 120 VAC 0.1 A @ 240 VAC	Electric Reset Motors 2.2 A @ 120 VAC 1.1 A @ 240 VAC	Lights 1.0 A @ 120 VAC 50/60 Hz 0.5 A @ 240 VAC 50/60 Hz	Pump Motor 10 A @ 115 VAC 60 Hz 5.3 A @ 230 VAC 50 Hz	DEF Heater 8.5 A @ 120 VAC
--	---	--	---	-------------------------------

25. Gasboy requires the use of one separate 15 A circuit breaker per dispenser for heater power on cold weather DEF models. This breaker must be separate from the Dispenser feed circuit breaker.

WARNING

The pump motor control/motor relay drive must not exceed 120 VAC across the two 20 AWG red wires or motor will be damaged.

IMPORTANT INFORMATION

Sharing conduit to the dispensers with other non-Gasboy devices is contrary to the installation and site preparation manuals and may void warranty.

Active STP Connections

The AtlasX Dispenser	STP1	STP2
First Product	X.....	
Second Product	X.....	X...

Reference Manuals

MDE-5692 AtlasX Fuel Systems Installation Manual
MDE-5693 AtlasX Fuel Systems Site Preparation Manual

Sheet	Contents	
	Description	Models
1	Cover Sheet (Safety, Installation Procedures, Electrical Rating, and References)	
2	AtlasX Dispenser with Mechanical Display	9153GX, 9153GXTW1, and 9153GXTW2
3	AtlasX with Mechanical Displays, Dual Pump Motors, 115/230 VAC	9153G, 9153GTW1, and 9153GTW2
4	AtlasX Dispenser with Electronic Display Field Wiring Diagram	8853GX, 8853GXTW1, 8853GXTW2, 9853GX, 9853GXTW1, 9853GXTW2, 9850GX, 9850GXTW1, and 9850GXTW2
5	AtlasX Self-contained Pump with Electronic Displays, Dual Pump Motors, Single Phase 115/120 VAC	8853G, 8853GTW1, 8853GTW2, 9853G, 9853GTW1, and 9853GTW2
6	AtlasX Self-contained Pump with Electronic Displays, Dual Pump Motors, Single Phase 220/230 VAC	8853G, 8853GTW1, 8853GTW2, 9853G, 9853GTW1, and 9853GTW2
7	DC Conduit; Pulse-out or LAN/WAN (CAT-5) Field Wiring Diagram	All electronic models

This Sheet
Safety and Installation Procedures

Used On
AtlasX Retail, Commercial, and DEF Dispensers with Mechanical and Electronic Displays.
AtlasX Retail and Commercial Self-Contained Pumps with Electronic and Mechanical Displays.

Field Wiring Diagram AtlasX
8800/9100/9800
Sheet 1 of 7

02/24	FE-371A
--------------	----------------

MECHANICAL UNIT MODELS: 9153GX, 9153GXTW1, and 9153GXTW2

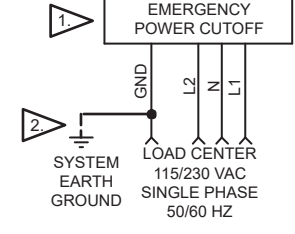
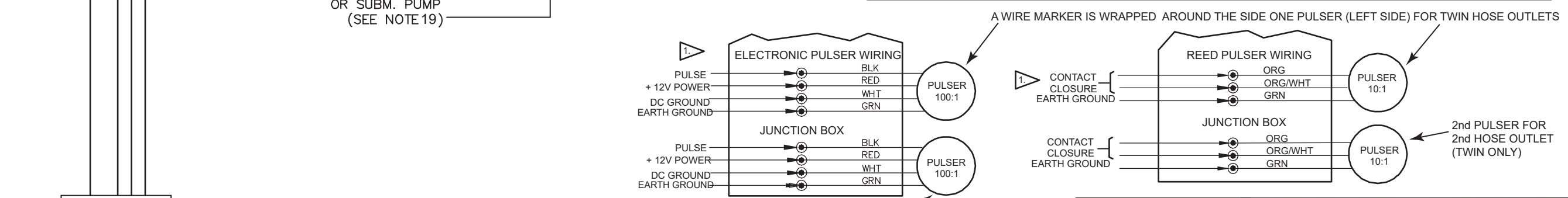
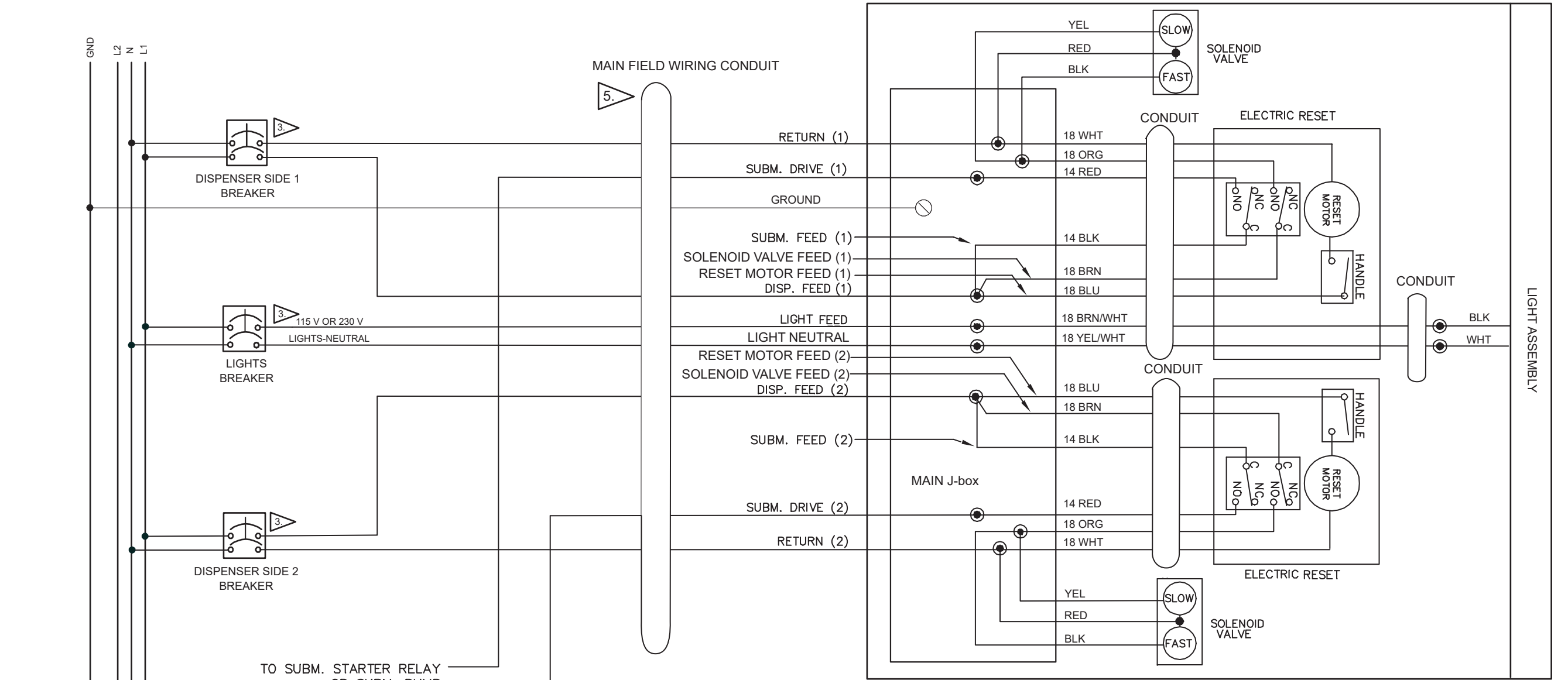

NOTE: Dual-sided unit shown. For single-sided unit make side 1 connections and cap side 2 wiring. All unused wiring must be capped properly.

This Sheet
AtlasX Dispenser with Mechanical Display

Symbols Chart

Wire Nut	
Earth Ground Screw Terminal	
Earth Ground	
No Connection	
Connection	

Wire Color Chart

Black	BLK
Brown	BRN
Blue	BLU
Gray	GRA
Green	GRN
Green with yellow stripe	GRN/YEL
Orange	ORG
Red	RED
Violet	VIO
White	WHT
White with black stripe	W/B
White with red stripe	W/R
Yellow	YEL

GASBOY

Field Wiring Diagram
AtlasX 9100 Dispenser
Sheet 2 of 7

02/24 | FE-371A

MECHANICAL UNIT MODELS: 9153G, 9153GTW1, 9153GTW2

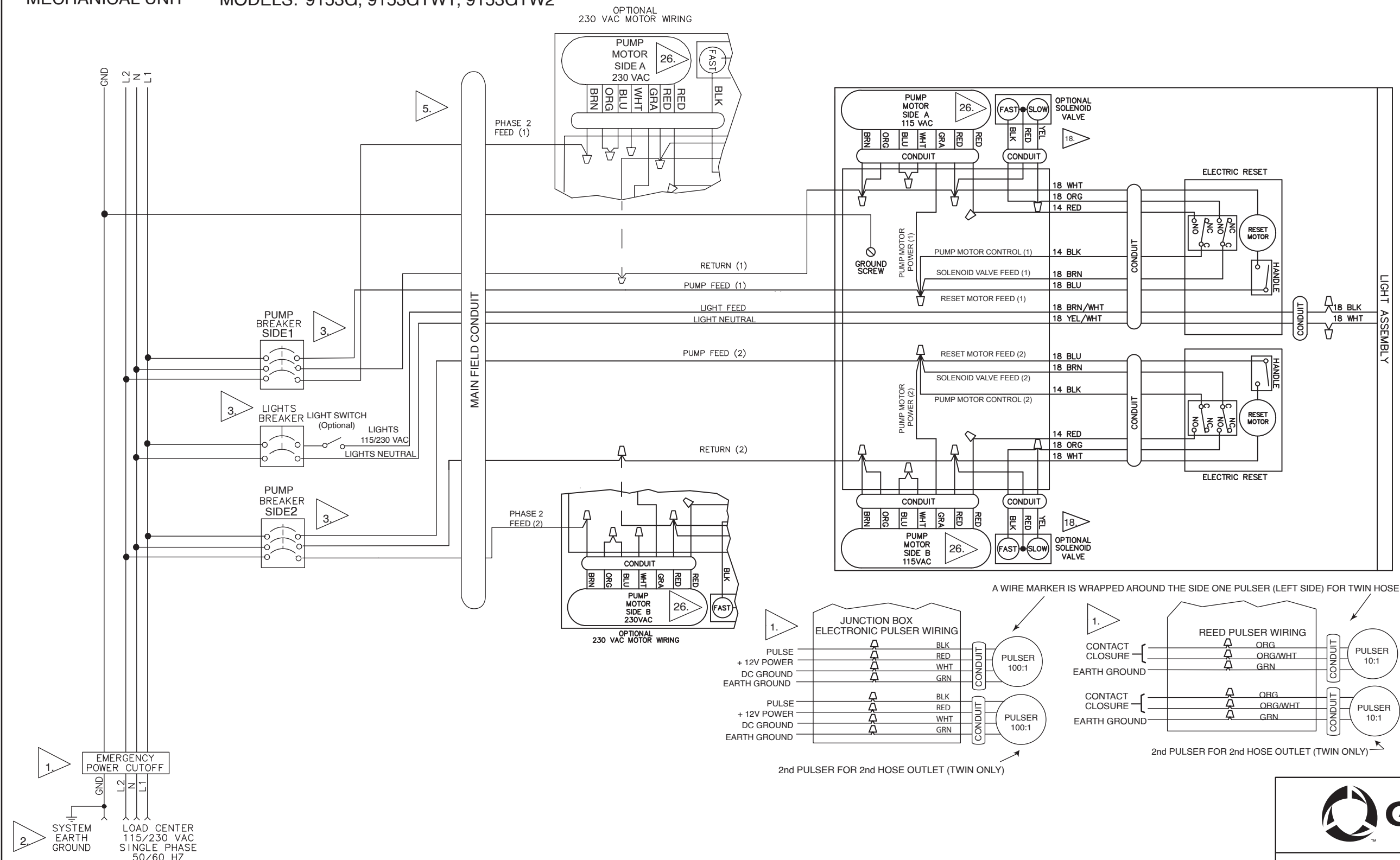

Symbols Chart

Wire Nut	
Crimp on Wire Connector	
Earth Ground Screw Terminal	
Earth Ground	
No Connection	
Connection	

Wire Color Chart

Black	BLK
Brown	BRN
Red	RED
Orange	ORG
Yellow	YEL
Green	GRN
Blue	BLU
Violet	VIO
Gray	GRA
White	WHT
White with black stripe	W/B
White with red stripe	W/R
Green with yellow stripe	G/Y

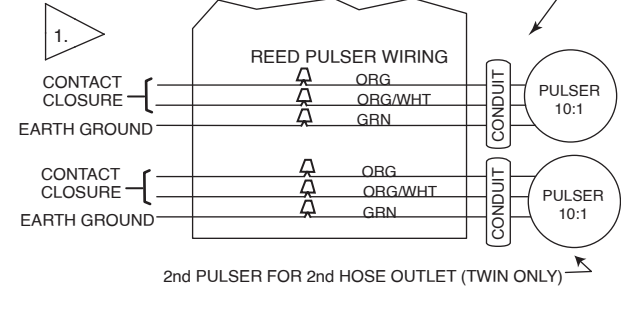
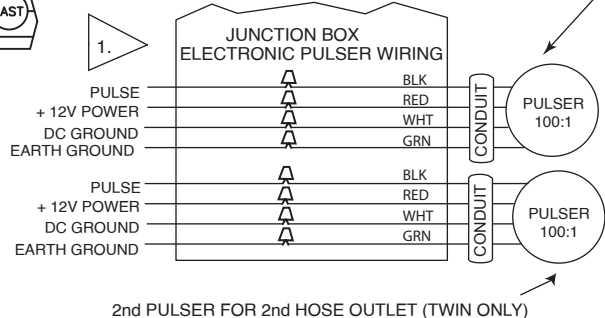

A WIRE MARKER IS WRAPPED AROUND THE SIDE ONE PULSER (LEFT SIDE) FOR TWIN HOSE

NOTE: Dual sided unit shown. For single sided unit make Side 1 connections and cap Side 2 wiring. All unused wiring must be properly capped.

This Sheet
AtlasX with Mechanical Display,
Dual Pump Motors, 115/230 VAC



Field Wiring Diagram
AtlasX 9100 Self-contained Pump
Sheet 3 of 7

02/24	FE-371A
-------	---------

ELECTRONIC UNIT

MODELS: 8853GX, 8853GXTW1, 8853GXTW2, 9853GX, 9853GXTW1, 9853GXTW2, 9850GX, 9850GXTW1, 9850GXTW2

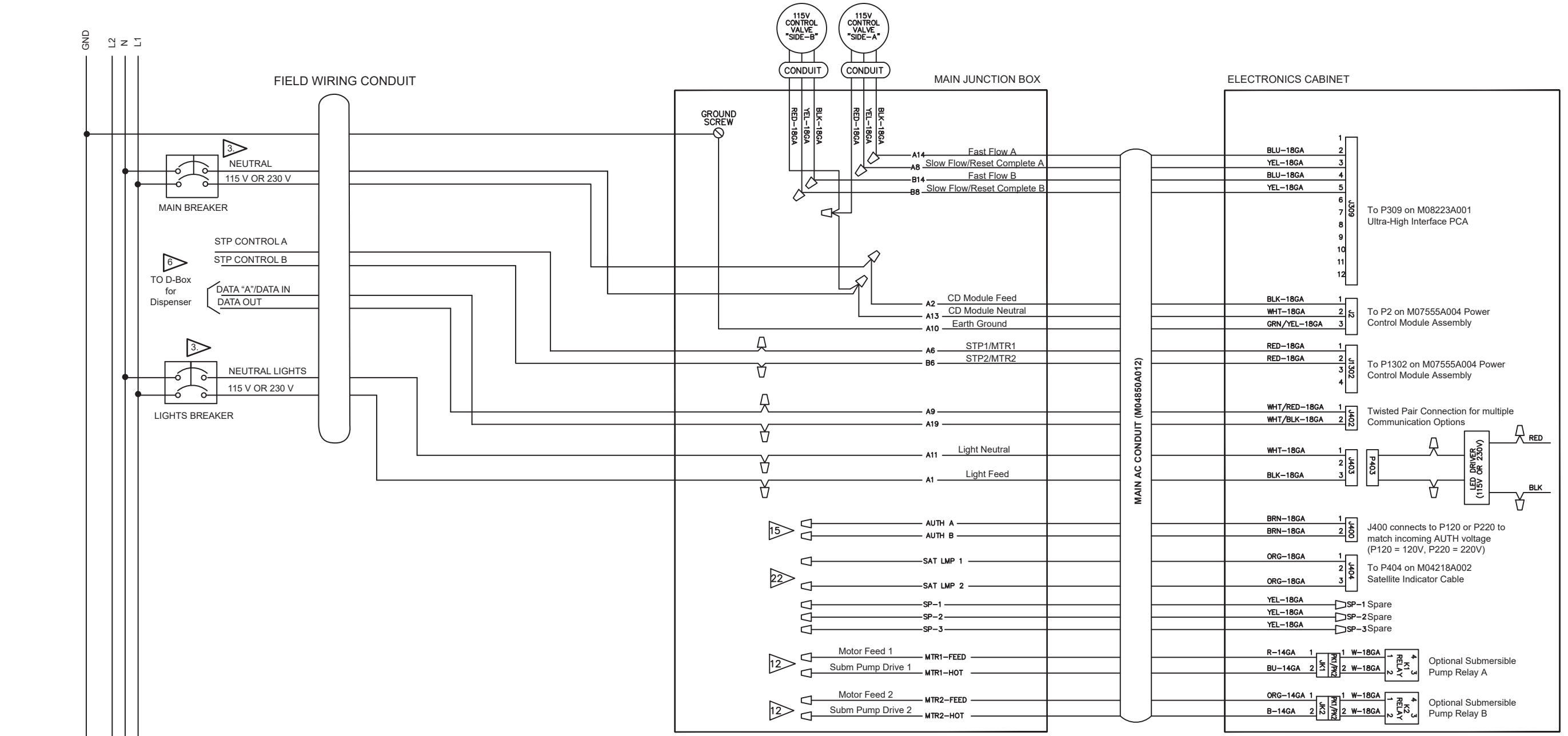

NOTES:
 1. Dual-sided unit shown. For single-sided unit make side 1 connections and cap side 2 wiring. All unused wiring must be capped properly.
 2. If pulse-out mode is not being used, the AUTH lines must remain open.

This Sheet
 AtlasX Dispenser with Electronic Display.

Symbols Chart

Wire Nut	
Crimped Wire Nut	
Earth Ground Screw Terminal	
Earth Ground	
No Connection	
Connection	

Wire Color Chart

Black	BLK
Brown	BRN
Red	RED
Orange	ORG
Yellow	YEL
Green	GRN
Blue	BLU
Violet	VIO
Gray	GRA
White	WHT
White with black stripe	W/B
White with red stripe	W/R
Green with yellow stripe	G/Y



Field Wiring Diagram
 AtlasX 8800/9800 Dispenser
 Sheet 4 of 7

02/24 FE-371A

ELECTRONIC UNIT MODELS: 8853G, 8853GTW1, 8853GTW2,
9853G, 9853GTW1, 9853GTW2

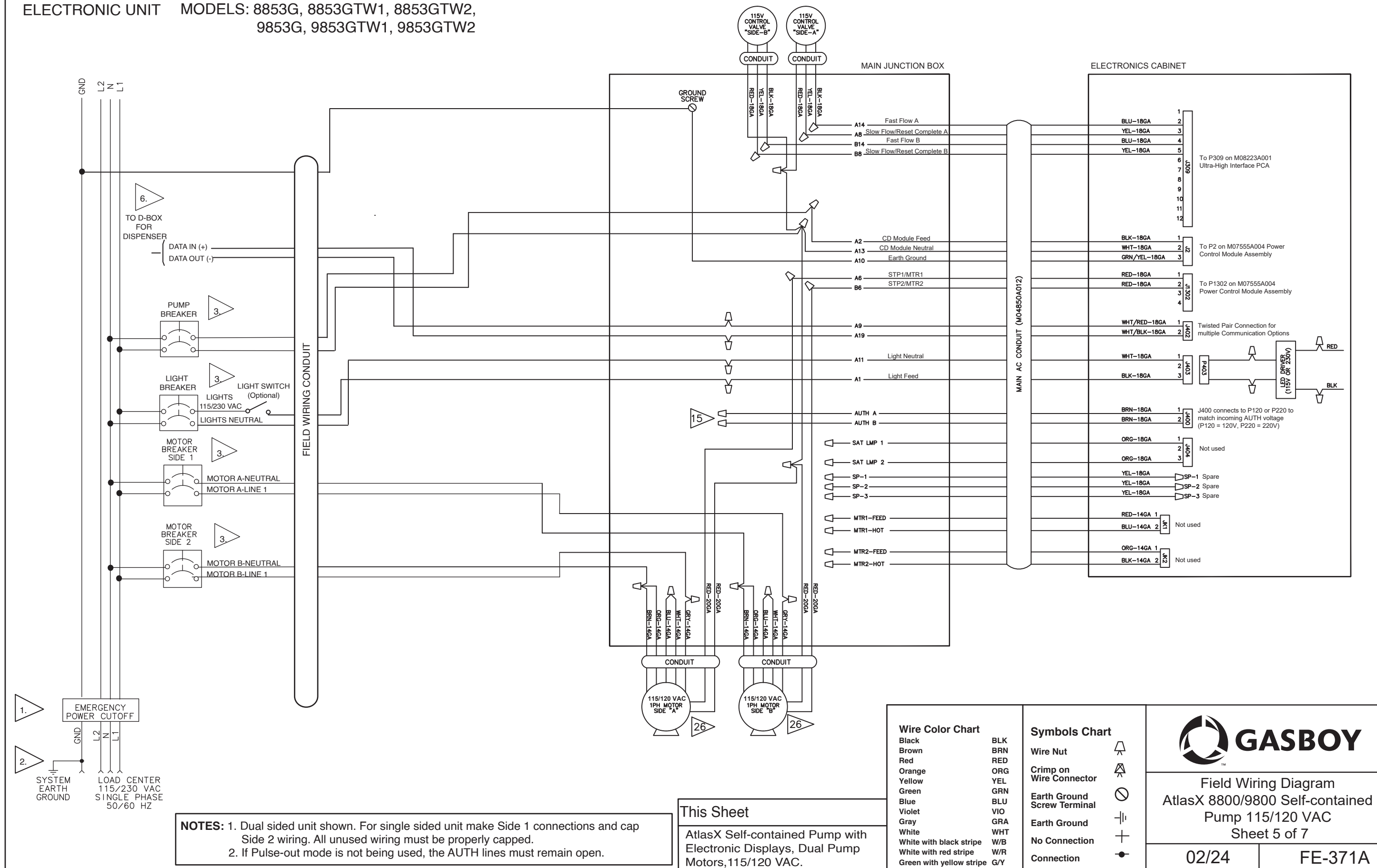

Field Wiring Diagram
AtlasX 8800/9800 Self-contained
Pump 115/120 VAC
Sheet 5 of 7

02/24

FE-371A

ELECTRONIC UNIT MODELS: 8853G, 8853GTW1, 8853GTW2, 9853G, 9853GTW1, 9853GTW2

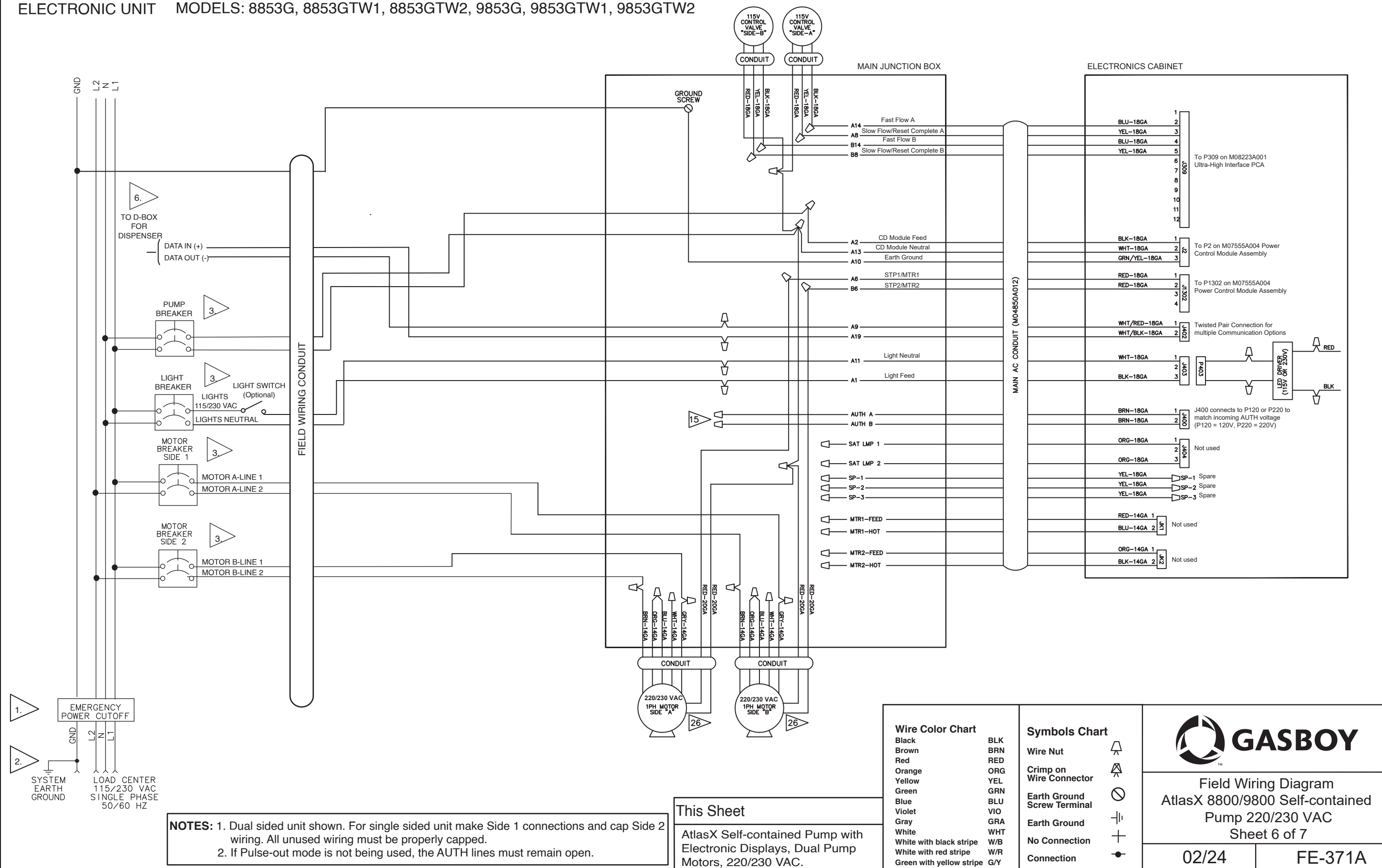

NOTES: 1. Dual sided unit shown. For single sided unit make Side 1 connections and cap Side 2 wiring. All unused wiring must be properly capped.
 2. If Pulse-out mode is not being used, the AUTH lines must remain open.

This Sheet
 AtlasX Self-contained Pump with Electronic Displays, Dual Pump Motors, 220/230 VAC.

Wire Color Chart	
Black	BLK
Brown	BRN
Red	RED
Orange	ORG
Yellow	YEL
Green	GRN
Blue	BLU
Violet	VIO
Gray	GRA
White	WHT
White with black stripe	W/B
White with red stripe	W/R
Green with yellow stripe	G/Y

Symbols Chart	
Wire Nut	⌘
Crimp on Wire Connector	⌘
Earth Ground Screw Terminal	⊖
Earth Ground	⊥
No Connection	+
Connection	●



Field Wiring Diagram
 AtlasX 8800/9800 Self-contained Pump 220/230 VAC
 Sheet 6 of 7

02/24	FE-371A
-------	---------

ELECTRONIC UNITS

MODELS: 8853G, 8853GX, 8853GTW1, 8853GXTW1, 8853GTW2, 8853GXTW2,
 9853G, 9853GX, 9853GTW1, 9853GXTW1, 9853GTW2, 9853GXTW2,
 9850GX, 9850GXTW1, 9850GXTW2

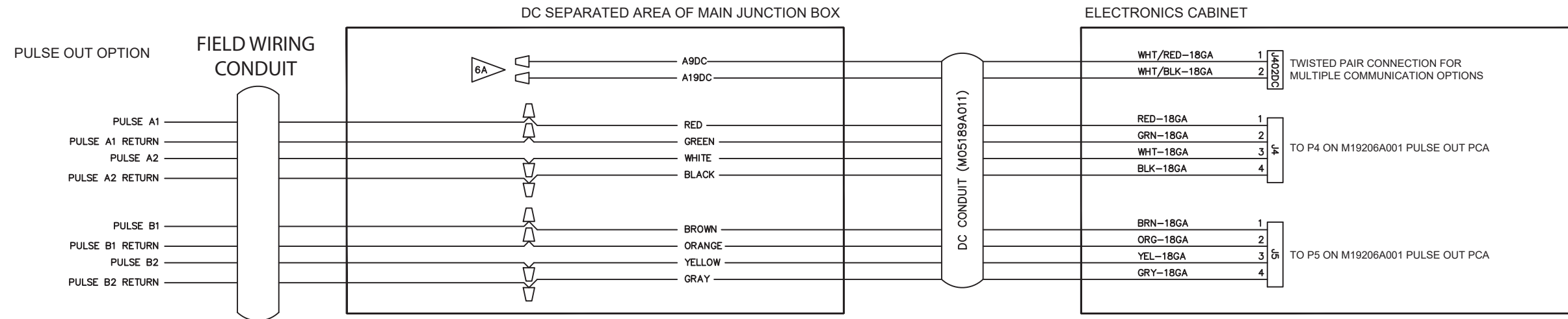

OR

LAN/WAN (CAT-5) OPTION

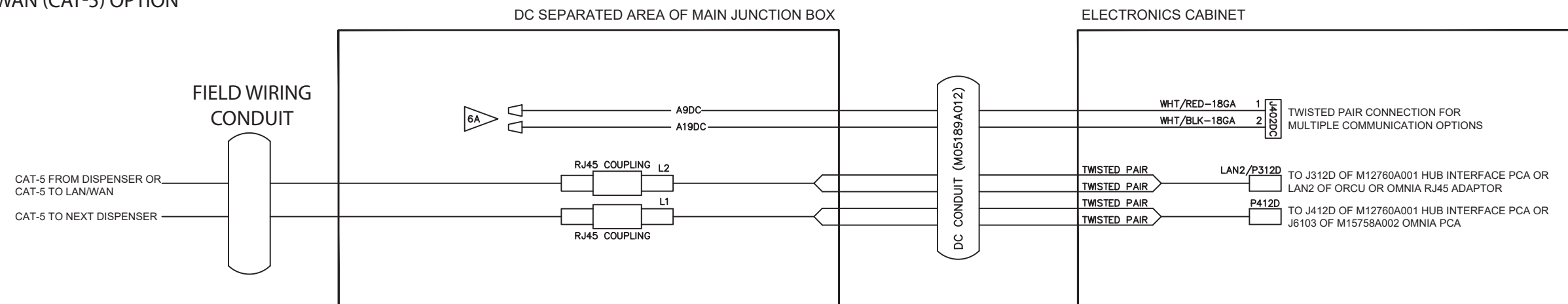

NOTE: All unused wiring must be capped properly.

This Sheet
 DC conduit and connections.

Symbols Chart		Wire Color Chart	
Wire Nut		Black	BLK
Crimped Wire Nut		Brown	BRN
Earth Ground Screw Terminal		Red	RED
Earth Ground		Orange	ORG
No Connection		Yellow	YEL
Connection		Green	GRN
		Blue	BLU
		Violet	VIO
		Gray	GRA
		White	WHT
		White with black stripe	W/B
		White with red stripe	W/R
		Green with yellow stripe	G/Y



GASBOY

Field Wiring Diagram
 AtlasX 8800/9800 DC Connections
 Sheet 7 of 7

01/24 FE-371A