



UM Ultrasonic Tee Flowmeter with Socket Fittings and Electronic Option QUDSBACE Shown

UM Ultrasonic Tee Flowmeter

NSF & Non-NSF Versions

1", 1-1/2", 2", 3", & 4" Socket

1", 1-1/2", 2", 3", & 4" FNPT

1", 1-1/2", & 2" FBSPT

3" & 4" ANSI Flange

3" & 4" DIN Flange



Please save these instructions for future reference. Read carefully before attempting to assemble, install, operate or maintain the product described.

Protect yourself and others by observing all safety information. Failure to comply with instructions could result in personal injury and/or property damage.

Please refer to back cover for information regarding this product's warranty and other important information.

DO NOT RETURN THIS PRODUCT TO THE STORE!

Please contact Great Plains Industries, Inc.® before returning any product. If you are missing parts, or experience problems with your installation, contact our Customer Support Department. We will be happy to assist you.

Call: 888-996-3837 or 316-686-7361

Email: Support-Meters@qplains.com

SAVE FOR YOUR RECORDS

Model #: _____

Serial#: _____

Purch. Date: _____

TABLE OF CONTENTS

<i>Getting Started</i>	4
<i>General Safety Instructions</i>	5
<i>Using the UM Manuals</i>	5
<i>General</i>	6
<i>Specifications</i>	6
<i>Socket Fitting Meters</i>	7
<i>NPT Fitting Meters</i>	8
<i>BSPT Fitting Meters</i>	9
<i>ANSI Flange Meters</i>	10
<i>DIN Flange Meters</i>	11
<i>K-Factor Chart</i>	12
<i>Installation</i>	13
<i>Connections - Socket Fitting Meters</i>	15
<i>Connections - NPT/BSPT Fitting Meters</i>	16
<i>Connections - ANSI/DIN Flange Meters</i>	16
<i>Connections - Wiring</i>	16
<i>Operation</i>	16
<i>Troubleshooting</i>	17
<i>Repair, Repair Parts List</i>	18
<i>Parts & Service</i>	19
<i>Warranty</i>	20

BEFORE YOU BEGIN

Usage Requirements

- This flowmeter is for use with water only.
- This flowmeter is not legal for trade applications.
- This flowmeter has a permanent factory setting for measuring water only.
- Flow must go uphill through the flowmeter, never downhill through the flowmeter to avoid air bubbles or air pockets captured in the Tee.



Power Source Requirements

- All ultrasonic electronics are DC powered either by battery or external power. Power requirements are dependent on the version of ultrasonic electronics.
- Specific versions of electronics are powered by a 3.6V lithium battery.
- Other versions of electronics require DC power from a customer-provided power supply in order to provide flow information back to the external equipment.
- See the Specifications section of the Ultrasonic Electronics Owner's Manual for information specific to the version of electronics mounted on your meter.



Tools and Materials (As Needed)

- Wire strippers, wire cutters.
- PVC pipe/fittings, PVC pipe primer, PVC pipe cement.
- Flange gaskets, bolts.

UNPACKING



Contents

1	UM Ultrasonic Tee Flowmeter, completely assembled with mounted electronics.
2	Owner's Manuals <ul style="list-style-type: none">• UM Ultrasonic Tee Flowmeter• UM Ultrasonic Electronics



Inspect

- After unpacking the unit, inspect carefully for any damage that may have occurred during transit. Check for loose, missing or damaged parts. Shipping damage claims must be filed with carrier.
- See General Safety Instructions, and all Cautions, Warnings, and Dangers as shown.



GENERAL SAFETY INSTRUCTIONS

IMPORTANT: It is your responsibility to:

- Ensure that all equipment operators have access to adequate instructions concerning safe operating and maintenance procedures.

▲ CAUTION

This product is not approved for use with petroleum products (diesel fuel, unleaded gasoline, jet fuel, kerosene, etc.), aromatic hydrocarbons or other incompatible chemicals.

▲ CAUTION

This product is not approved for use in hazardous locations.

▲ WARNING

When applying power, adhere to specifications listed in appropriate electronics manual.

▲ CAUTION

Disconnect external power before attaching or detaching input or output wires.

▲ WARNING

Compatibility of this product's material and the process fluid and/or environment should be considered prior to putting into service.

▲ WARNING

Product should never be operated outside its published specifications for temperature or pressure. See specifications for your model.

▲ WARNING

Make sure flow and pressure have been eliminated from process pipe prior to installing or removing product.

▲ CAUTION

Installation near high electromagnetic fields and high current fields is not recommended and may result in inaccurate readings.

▲ CAUTION

Do not allow water to freeze in flowmeter. Ice expansion may burst the plastic housing.

▲ CAUTION

Do not allow this meter to be used with steam.

- When working in hazardous environments, always exercise appropriate safety precautions.
- Be sure O-rings and seals are kept in good repair.

USING THE UM MANUALS (See Figure A)

A - Owner's Manual, UM Ultrasonic Tee Flowmeter

This manual contains operating information and specifications for all UM Tee flowmeters.

B - Owner's Manual, UM Ultrasonic Electronics

This manual contains operating information and specifications for the QUDSBACE & QUDSBAN1 and QUC1LPCE & QUC1LPN1 electronic options. Each electronic option includes the ultrasonic insert, electronic module, and Q9 computer display.

A typical model number is shown below for a 2" UM Tee meter, socket ports, with display and NSF certification.

UM050SKPRUXXA20-QUDSBAN1-GMB

The (8) characters between the dashes denote the electronic option.

For clarity of manual references:

- Q9 refers to the computer display.
- QUDSBACE & QUC1LPCE refers to the "standard" electronic options.
- QUDSBAN1 & QUC1LPN1 refers to the "NSF Certified" electronic options.

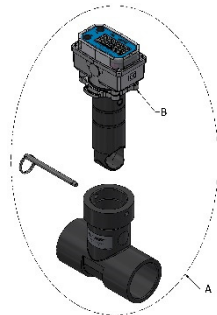

Figure A
(1-1/2" Tee Meter
w/Socket Fittings &
Option QUDSBACE Shown)

GENERAL

The FLOMEC® Ultrasonic Tee meter consists of a tee housing, specially designed to accept the FLOMEC Ultrasonic Electronics package. The electronics package consists of the ultrasonic insert, the electronics module, and the Q9 computer display.

Ultrasonic Insert: The ultrasonic insert locates inside the tee locked in place with the quick release pin. It is important that the flow arrow on the insert points in the direction of the piping flow.

Electronic Module: The electronic module is located atop the ultrasonic insert and connected to it by a 10-pin ribbon cable. The electronic module is retained to the ultrasonic insert by a backup plate with screws.

Computer Display: The Q9 computer display is located atop the electronic module and connected to it by a 10-pin flex cable. The computer display is retained to the electronic module with screws.

***To Rotate Display:** If the computer display is not oriented for your needs, loosen the screws of the backup plate (that secures the electronic module to the top of the insert) and rotate the electronic module with attached computer display as required. The electronic module and the computer display must rotate as a unit.*

Inlet/Outlet Fittings: There are (5) types of inlet/outlet fittings available for the FLOMEC Ultrasonic Tee meter:

- Socket (Available in all sizes)
- FNPT (Available in all sizes)
- FBSPT (Available in 1", 1-1/2" & 2" only)
- ANSI Flange (Available in 3" & 4" only)
- DIN Flange: (Available in 3" & 4" only)

SPECIFICATIONS - Common

	UM025 1 Inch	UM040 1-1/2 Inch	UM050 2 Inch	UM080 3 Inch	UM100 4 Inch
Type	Ultrasonic Flowmeter				
Tee Housing Material (With Integrated Socket Fitting)	SCH 80 PVC (Polyvinyl chloride)				
Fitting Material (NPT, BSPT, ANSI Flange, DIN Flange, Spacer)	SCH 80 PVC (Polyvinyl chloride)				
Flow Rate	0.22-33 GPM 0.83-124.92 L/min 0.1-15 ft ³ /sec	0.55-82 GPM 2.08-310.41 L/min 0.1-15 ft ³ /sec	0.92-138 GPM 3.48-522.39 L/min 0.1-15 ft ³ /sec	2.06-309 GPM 7.80-1169.70 L/min 0.1-15 ft ³ /sec	3.58-537 GPM 13.55-2032.78 L/min 0.1-15 ft ³ /sec
Max. Working Pressure	203 PSI @ 70°F (14.0 bar @ 21°C) Teas are marked with hallmark of size, part number, SCH80 and pressure				
Operating Temperature Process Fluid	+32°F to +140°F (0°C to +60°C)				
Operating Temperature Ambient Air	+0°F to +130°F (-18°C to +55°C)				
Storage Temperature Ambient Air	-40°F to +158°F (-40°C to +70°C)				

SPECIFICATIONS - Socket Fitting Meters

Model	UM025SK	UM040SK	UM050SK	UM080SK	UM100SK
Size	1 Inch	1-1/2 Inch	2 Inch	3 Inch	4 Inch
Inlet / Outlet Connections	1 in. Socket	1 1/2 in. Socket	2 in. Socket	3 in. Socket	4 in. Socket
Tee Housing Weight	1.45 lbs. (0.66kg)	1.62 lbs. (0.73kg)	1.89 lbs. (0.86kg)	3.02 lbs. (1.37kg)	3.71 lbs. (1.68kg)

Dimensions

Model	UM025SK	UM040SK	UM050SK	UM080SK	UM100SK
Size	1 Inch	1-1/2 Inch	2 Inch	3 Inch	4 Inch
A. Length	4.25 in. (108mm)	4.90 in. (124mm)	5.56 in. (141mm)	6.63 in. (168mm)	7.38 in. (187mm)
B. Height ²	5.38 in. (137mm)	5.63 in. (143mm)	6.12 in. (156mm)	7.20 in. (183mm)	8.41 in. (213mm)
C. Width (at widest point)	2.50 in. (64mm)	2.50 in. (64mm)	2.88 in. (73mm)	4.18 in. (106mm)	5.23 in. (133mm)
D. Pipe end stop gap	1.97 in. (50mm)	2.12 in. (54mm)	2.53 in. (64mm)	2.88 in. (73mm)	2.88 in. (73mm)

² Electronic options QUDSBACE & QUDSBAN1 and QUC1LPCE & QUC1LPN1 adds 2.25 in. (57mm) to overall height.

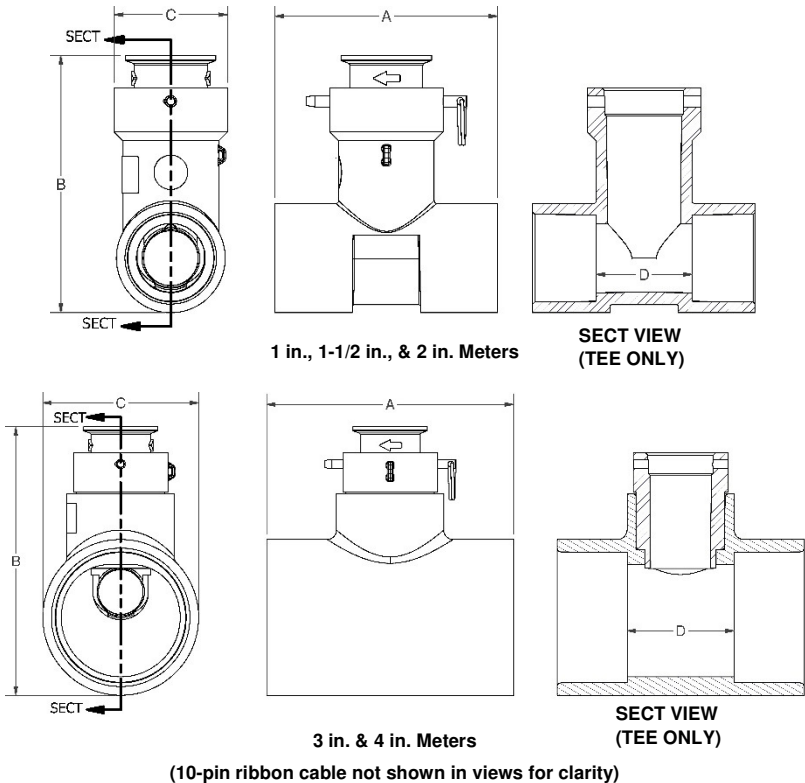

Figure 1

SPECIFICATIONS – NPT Fitting Meters

Model	UM025NF	UM040NF	UM050NF	UM080NF	UM100NF
Size	1 Inch	1-1/2 Inch	2 Inch	3 Inch	4 Inch
Inlet / Outlet Connections	1 in. NPT Female	1 1/2 in. NPT Female	2 in. NPT Female	3 in. NPT Female	4 in. NPT Female
Tee Housing Weight	1.67 lbs. (0.76kg)	2.12 lbs. (0.96kg)	2.63 lbs. (1.19kg)	5.81 lbs. (2.63kg)	7.96 lbs. (3.61kg)

Dimensions

Model	UM025NF	UM040NF	UM050NF	UM080NF	UM100NF
Size	1 Inch	1-1/2 Inch	2 Inch	3 Inch	4 Inch
A. Length	6.50 in. (165mm)	7.44 in. (189mm)	8.22 in. (209mm)	14.06 in. (357mm)	16.31 in. (414mm)
B. Height ²	5.37 in. (136mm)	5.71 in. (145mm)	6.24 in. (158mm)	7.24 in. (184mm)	8.41 in. (213mm)
C. Width (at widest point)	2.50 in. (64mm)	2.96 in. (75mm)	3.61 in. (92mm)	4.25 in. (108mm)	5.87 in. (149mm)

² Electronic options QUDSBACE & QUDSBAN1 and QUC1LPCE & QUC1LPN1 adds 2.25 in. (57mm) to overall height.

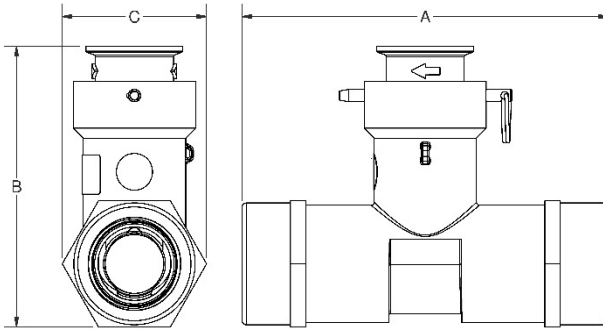

1 in., 1-1/2 in., & 2 in. Meters

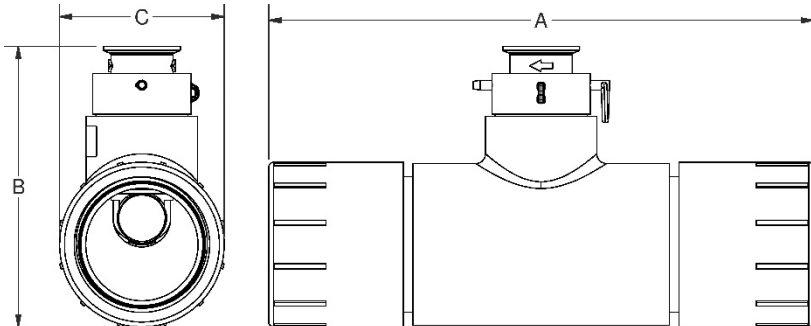

3 in. & 4 in. Meters

(10-pin ribbon cable not shown in views for clarity)

Figure 1A

SPECIFICATIONS – BSPT Fitting Meters

Model	UM025TF	UM040TF	UM050TF
Size	1 Inch	1-1/2 Inch	2 Inch
Inlet / Outlet Connections	1 in. BSPT Female	1 1/2 in. BSPT Female	2 in. BSPT Female
Tee Housing Weight	1.65 lbs. (0.75kg)	1.96 lbs. (0.89kg)	2.13 lbs. (0.97kg)

Dimensions

Model	UM025TF	UM040TF	UM050TF
Size	1 Inch	1-1/2 Inch	2 Inch
A. Length	6.78 in. (172mm)	7.40 in. (188mm)	8.09 in. (205mm)
B. Height ²	5.38 in. (137mm)	5.63 in. (143mm)	6.12 in. (155mm)
C. Width (at widest point)	2.50 in. (64mm)	2.50 in. (64mm)	2.88 in. (73mm)

² Electronic options QUDSBACE & QUDSBAN1 and QUC1LPCE & QUC1LPN1 adds 2.25 in. (57mm) to overall height.

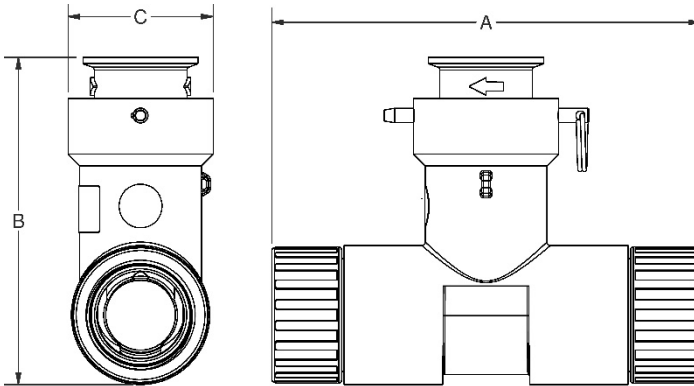

1 in., 1-1/2 in., & 2 in. Meters

(10-pin ribbon cable not shown in views for clarity)

Figure 1B

SPECIFICATIONS – ANSI Flange meters

Model	UM080FA	UM100FA
Size	3 Inch	4 Inch
Inlet / Outlet Connections	3 in. ANSI Flange	4 in. ANSI Flange
Tee Housing Weight	7.77 lbs. (3.52kg)	11.08 lbs. (5.03kg)

Dimensions

Model	UM080FA	UM100FA
Size	3 Inch	4 Inch
A. Length	13.38 in. (340mm)	13.38 in. (340mm)
B. Height ²	8.86 in. (225mm)	10.30 in. (262mm)
C. Width (at widest point)	7.50 in. (191mm)	9.00 in. (229mm)

² Electronic options QUDSBACE & QUDSBAN1 and QUC1LPCE & QUC1LPN1 adds 2.25 in. (57mm) to overall height.

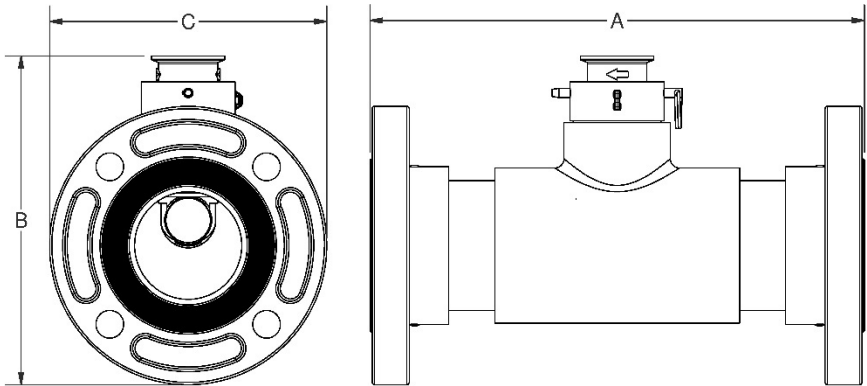

3 in. & 4 in. Meters

(10-pin ribbon cable not shown in views for clarity)

Figure 1C

SPECIFICATIONS – DIN Flange Meters

Model	UM080FD	UM100FD
Size	3 Inch	4 Inch
Inlet / Outlet Connections	3 in. DIN Flange	4 in. DIN Flange
Tee Housing Weight	8.19 lbs. (3.71kg)	10.24 lbs. (4.64kg)

Dimensions

Model	UM080FD	UM100FD
Size	3 Inch	4 Inch
A. Length	13.38 in. (340mm)	13.38 in. (340mm)
B. Height ²	9.11 in. (231mm)	10.05 in. (255mm)
C. Width (at widest point)	8.00 in. (203mm)	8.50 in. (216mm)

² Electronic options QUDSBACE & QUDSBAN1 and QUC1LPCE & QUC1LPN1 adds 2.25 in. (57mm) to overall height.

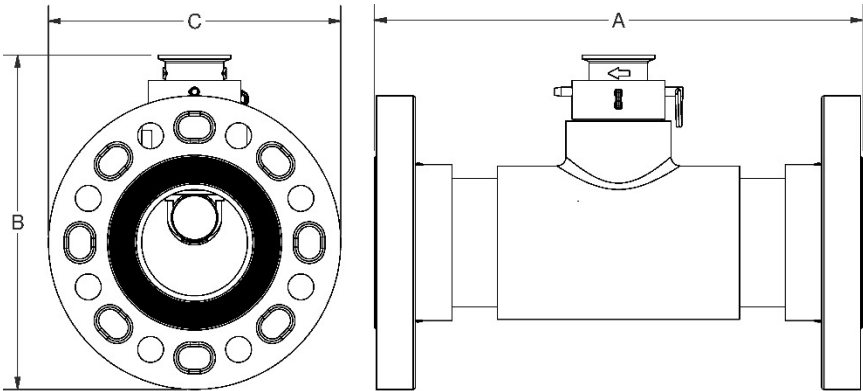

3 in. & 4 in. Meters

(10-pin ribbon cable not shown in views for clarity)

Figure 1D

SPECIFICATIONS (Continued)

K-Factor Chart

Meter Model	Size	Adjoining Pipe	Typical K-Factor	
			Pulses/Gal	Pulses/Litre
UM025	1 in.	Class 200	102.96	27.20
		Sch 40	107.62	28.43
		Sch 80	112.06	29.60
UM040	1-1/2 in.	Class 200	74.74	19.74
		Sch 40	75.73	20.00
		Sch 80	76.34	20.17
UM050	2 in.	Class 200	39.82	10.52
		Sch 40	41.07	10.85
		Sch 80	41.19	10.88
UM080	3 in.	Class 200	13.25	3.50
		Sch 40	14.07	3.72
		Sch 80	14.69	3.88
UM100	4 in.	Class 200	7.32	1.93
		Sch 40	7.42	1.96
		Sch 80	7.59	2.00

If using a UM with an irrigation controller, please see the following K-factor Calculator link for more detailed information: <https://flocemeters.com/qs200-k-factor-calculator/>.

K-Factor Information

NOTE: The meter size is molded on the vertical stem of the Tee.

FLOMEC ultrasonic flowmeters use typical K-Factor values specific to the adjoining pipe used in the application for greatest accuracy during calibration. These values are derived by calibrating the meters using NIST traceable instrumentation. The typical K-factor values for each meter are listed above.

IMPORTANT: The K-factors provided are for reference. Accuracy can be affected by plumbing configuration, fluid condition, adjoining pipe schedule, and entrapped air.

INSTALLATION

Typical UM Tee meter (Tee with ultrasonic electronics) shown below

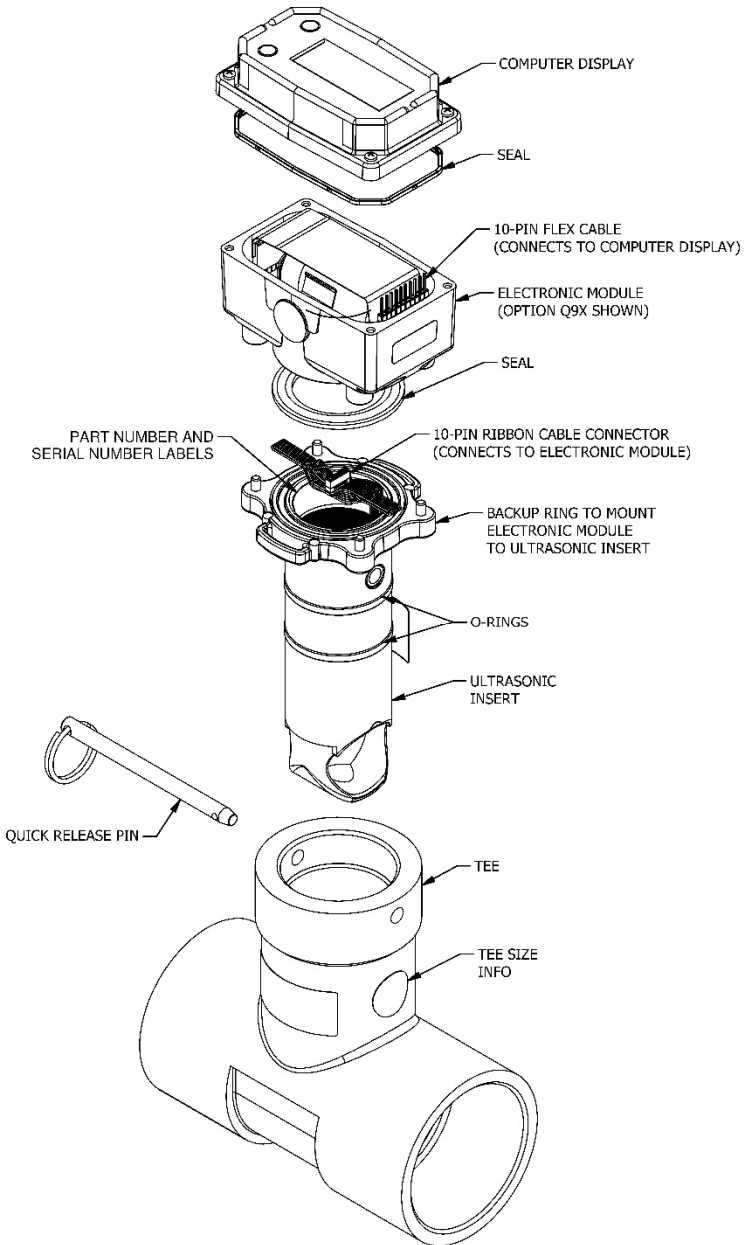

Figure 2
(UM050SK shown)

INSTALLATION (Continued)

NOTE: Allow room above the insert for the electronic module and computer display (see Specifications for dimensions).

UM ultrasonic meters should be installed with straight runs of pipe equal to 10 pipe diameters upstream, and 5 times the pipe diameter downstream to prevent turbulence that can decrease the meter's accuracy. Without these straight runs, UM meters will still detect higher and lower than expected flows and unscheduled flows. The arrow embossed on the insert housing denotes the flow direction.

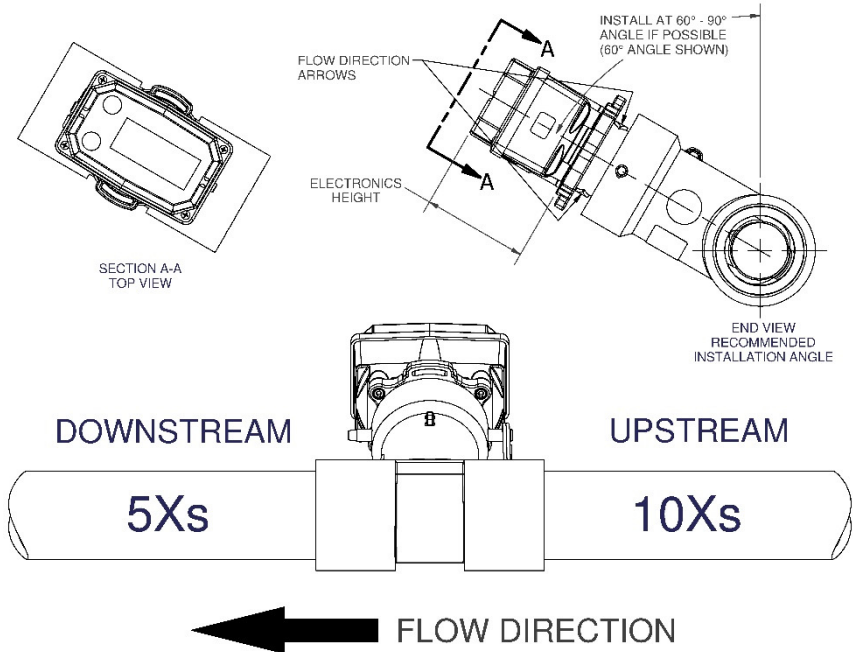

Figure 3
(UM040SK with Option QUDSBACE electronics shown)

Installing Tee Meter onto Pipe

NOTE: There is no need to remove the insert to install the meter. The meter must be installed with the arrow on the insert pointing in the flow direction.

If the meter is accidentally installed backwards, simply remove the insert, rotate 180 degrees so the arrow points in the flow direction, and reinstall the insert.

The Tee is bi-directional; the insert is not. The insert operates correctly as long as the insert arrow is pointed in the direction of flow. The insert can be rotated 180 degrees, so its arrow can always be pointed in the direction of flow regardless of Tee installation.

If space allows, install Tee/insert at a 60° to 90° angle from vertical (see Figure 3).

NOTE: For 1-inch pipe installations, this 60° to 90° angle is especially important for the most accurate meter operation.

Note: Flow must go uphill through the meter, never downhill through the meter to avoid air bubbles or air pockets captured in the Tee.

INSTALLATION (Continued)

Socket Fitting Meters - Connections

1. Remove all burrs from the O.D. and I.D. edges of the pipe ends, and the I.D. edges of the Tee sockets (see Figure 4).
2. Clean and apply primer to the pipe ends and Tee sockets (see Figure 5)
3. Apply PVC cement to pipe ends and Tee sockets and quickly assemble the parts while the cement is fluid, following the cement manufacturer's instructions (see Figure 6).
4. Hold the cemented parts together for at least 30 seconds.

NOTE: The graphics below show the Tee meter as it comes from the factory (completely assembled). For convenience during the installation process, the ultrasonic insert with attached electronics can be removed from the Tee by removing the quick release pin and lifting the insert out of the Tee.

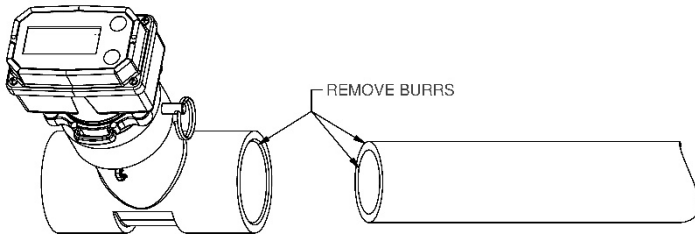

Figure 4
(UM040SK with Option QUDSBACE electronics shown)

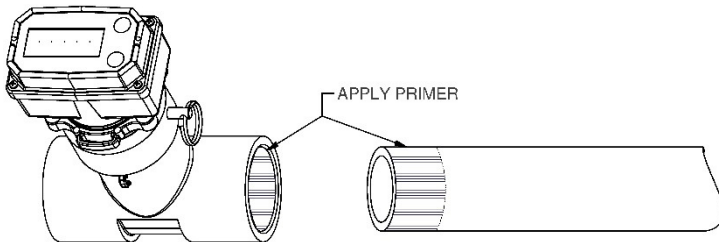

Figure 5
(UM040SK with Option QUDSBACE electronics shown)

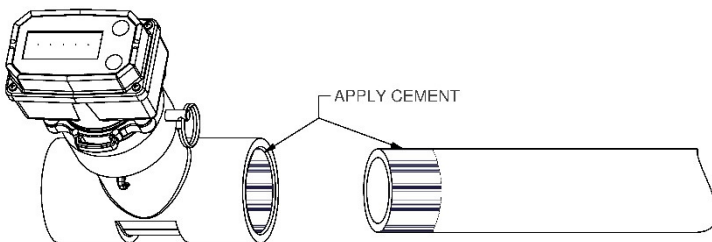

Figure 6
(UM040SK with Option QUDSBACE electronics shown)

INSTALLATION (Continued)

NPT and BSPT Fitting Meters - Connections

Installation to metal connections is not recommended.

1. Seal all pipe threads with an appropriate non-lubricated thread sealant (such as Loctite® No More Leaks™ Plastic Pipe Thread Sealant or NSF equivalent for NSF applications). Make sure the thread sealant does not intrude into the flow path.
2. Attach meter with arrow pointed in the direction of fluid flow.
3. Hand tighten the meter at the housing ends. DO NOT use a wrench or similar tool to tighten. This can damage the housing.

ANSI and DIN Flange Fitting Meters - Connections

Installation to metal connections is not recommended. Customer to provide the following:

- Ring Gaskets or Full-Face Gaskets approved for use with type flange installed (ANSI or DIN), application (NSF or non-NSF), and the fluid being monitored. (2 gaskets required).
- 5/8-inch bolts and nuts for ANSI flanges. Four per side for 3-inch meters; eight per side for 4-inch meters.
- 16 mm bolts and nuts for DIN flanges. Eight per side for 3-inch and 4-inch meters.
- Torque bolts using a star pattern to 25 ft-lbs (33.8 Nm). Supplied flanges are two-piece Van Stone style and allow the meter to be oriented regardless of the mating flanges position.

Wiring Connections

The ultrasonic Tee meter comes from the factory completely assembled. Electronic options QUDSBACE & QUDSBAN1 (battery powered) can be used immediately.

See UM Ultrasonic Electronics owner's manual for wiring information on electronic options QUC1LPCE & QUC1LPN1 (loop powered). It must be connected to a customer provided power supply.

OPERATION

There are no user adjustments or actions required for the Tee. User adjustments of electronic operations are explained in **920901-05 UM Ultrasonic Electronics** owner's manual received with this meter. The table below highlights some of the special features that a customer may want to adjust to fine tune their meter to the process.

Special Feature	Description	Manual Location
Built in flow meter diagnostics	Diagnostic features that allow the user to troubleshoot application issues	Q9 Display: Operation: Diagnostic Mode
Selectable volume and time-base units	User configurable accumulated volume units and flow rate time-base	Q9 Display: Operation: Configuration Mode: Volume Unit
Adjustable scaled pulse output K-factor	User configurable pulse output K-factor (pulses/volume) value can be adjusted for interoperability with various customer equipment	Q9 Display: Operation: Configuration Mode: Electronic Module Options
Adjustable 4-20ma output	User configurable zero and span settings to adjust product for specific application flow rates	Q9 Display: Operation: Configuration Mode: Electronic Module Options
Field calibration	User calibration of the flow meter using one of three available methods (Dispense/Display, Percentage Adjustment, or K-factor Entry)	Q9 Display: Operation: Field Calibration Mode

TROUBLE SHOOTING

1. Entrained air is air bubbles suspended in the water flow. Entrained air creates errors in accuracy of ultrasonic technology meters. Recommend a maximum of 10% entrained air in the water flow.
2. Flow must go uphill through the meter, never downhill through the meter to avoid air bubbles or air pockets captured in the Tee.
3. Do not install within 20 pipe diameters downstream of pressure regulation equipment. These devices cause any entrained air in the line to expand, and could cause your FLOMEC Ultrasonic Meter to become inaccurate.
4. The faces of the transducers need to be clean and free of oily substances for accurate operation. Do not touch transducers with fingers, oily rags, etc.

DO NOT use wire brushes or abrasives to clean the faces of the transducers (see Figure 7).

5. Ensure the flow direction arrow is pointing in the direction of flow for correct functionality.
6. Ensure the quick release pin is installed in the tee to maintain pressure and alignment of the insert in the tee.

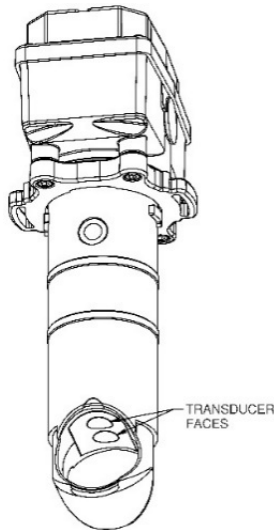

Figure 7
(Option QUDSBACE electronics shown)

REPAIR

There are no repairs that can be made to the Tee housing. Replacement Tee housings are available as replacement parts.

See the specific section of the Ultrasonic Electronics Manual for available repair parts for the ultrasonic insert, electronic module, and computer display.

REPAIR PARTS LIST

Model No.	Description	Part Number
UM025SK	HOUSING, 1 INCH TEE, PVC, SPARE	146010-511
UM040SK	HOUSING, 1-1/2 INCH TEE, PVC, SPARE	146015-511
UM050SK	HOUSING, 2 INCH TEE, PVC, SPARE	146020-511
UM080SK	HOUSING ASSEMBLY, 3 INCH TEE, PVC, SPARE	146030-512
UM100SK	HOUSING ASSEMBLY, 4 INCH TEE, PVC, SPARE	146040-512
UM025NF	HSG ASSY, UM, 1" FNPT, SPARE	146023-501
UM040NF	HSG ASSY, UM, 1-1/2" FNPT, SPARE	146023-502
UM050NF	HSG ASSY, UM, 2" FNPT, SPARE	146023-503
UM080NF	HSG ASSY, UM, 3" FNPT, SPARE	146023-504
UM100NF	HSG ASSY, UM, 4" FNPT, SPARE	146023-505
UM025TF	HSG ASSY, UM, 1" FBSPT, SPARE	146023-506
UM040TF	HSG ASSY, UM, 1-1/2" FBSPT, SPARE	146023-507
UM050TF	HSG ASSY, UM, 2" FBSPT, SPARE	146023-508
UM080FA	HSG ASSY, UM, 3" ANSI FLNG, SPARE	146023-509
UM100FA	HSG ASSY, UM, 4" ANSI FLNG, SPARE	146023-510
UM080FD	HSG ASSY, UM, 3" DIN FLNG, SPARE	146023-511
UM100FD	HSG ASSY, UM, 4" DIN FLNG, SPARE	146023-512

PARTS & SERVICE

For warranty consideration, parts, or other service information, please contact your local distributor. If you need further assistance, contact the GPI Customer Service Department in Wichita, Kansas, during normal business hours.

A toll free number is provided for your convenience.

1-888-996-3837

To obtain prompt, efficient service, always be prepared with the following information:

- The model number of your meter.
- The serial number or manufacturing date code of your meter.
- Part descriptions and numbers.

For warranty work, always be prepared with your original sales slip or other evidence of purchase date.

IMPORTANT: Please contact GPI before returning any parts. It may be possible to diagnose the trouble and identify needed parts in a telephone call.

 CAUTION

Do not return this product without prior approval from the GPI Customer Service Department. Due to strict government regulations, GPI cannot accept parts unless they have been drained and cleaned.



FLOMEC® TWO-YEAR LIMITED WARRANTY

Great Plains Industries, Inc. 5252 E. 36th Street North, Wichita, KS USA 67220-3205, hereby provides a limited warranty against defects in material and workmanship on all products manufactured by Great Plains Industries, Inc. This product includes a 2-year warranty. Manufacturer's sole obligation under the foregoing warranties will be limited to either, at Manufacturer's option, replacing or repairing defective Goods (subject to limitations hereinafter provided) or refunding the purchase price for such Goods theretofore paid by the Buyer, and Buyer's exclusive remedy for breach of any such warranties will be enforcement of such obligations of Manufacturer. The warranty shall extend to the purchaser of this product and to any person to whom such product is transferred during the warranty period.

The warranty period shall begin on the date of manufacture or on the date of purchase with an original sales receipt. This warranty shall not apply if:

- A. the product has been altered or modified outside the warrantor's duly appointed representative;
- B. the product has been subjected to neglect, misuse, abuse or damage or has been installed or operated other than in accordance with the manufacturer's operating instructions.

To make a claim against this warranty, or for technical assistance or repair, contact your FLOMEC distributor or contact FLOMEC at one of the locations below.

In North or South America contact

Great Plains Industries, Inc.

5252 East 36th St. North
Wichita, KS 67220-3205
USA

888-996-3837

www.flomecmeters.com
(North America)

Outside North or South America contact

GPI Australia
(Trimec Industries Pty. Ltd.)

12/7-11 Parraweena Road
Caringbah NSW 2229
Australia

+61 02 9540 4433

www.flomec.com.au

The company will step you through a product troubleshooting process to determine appropriate corrective actions.

GREAT PLAINS INDUSTRIES, INC., EXCLUDES LIABILITY UNDER THIS WARRANTY FOR DIRECT, INDIRECT, INCIDENTAL AND CONSEQUENTIAL DAMAGES INCURRED IN THE USE OR LOSS OF USE OF THE PRODUCT WARRANTED HEREUNDER.

The company herewith expressly disclaims any warranty of merchantability or fitness for any particular purpose other than for which it was designed.

This warranty gives you specific rights and you may also have other rights which vary from U.S. state to U.S. state.

NOTE: In compliance with MAGNUSON MOSS CONSUMER WARRANTY ACT – Part 702 (governs the resale availability of the warranty terms).



Certified to
NSF/ANSI 61-G & 372

IP67



Wichita / Sydney

GREAT PLAINS INDUSTRIES



© 2022 Great Plains Industries, Inc., All Rights Reserved.

Great Plains Industries, Inc. / 888-996-3837 / flomecmeters.com