

# **FuelWORKS**<sup>®</sup>

Solution for Fuel Transfer

## **AC Fuel Transfer Pump Instruction Manual**

---

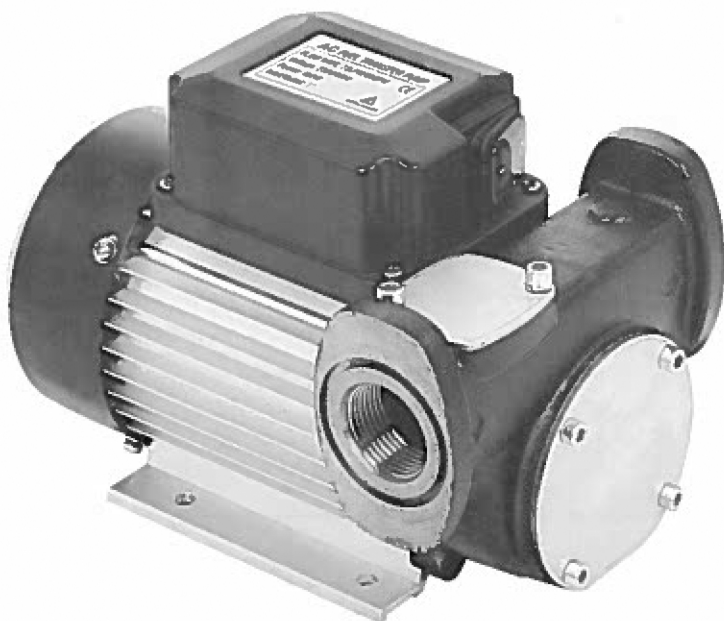

### **WARNING:**

Read carefully and understand all INSTRUCTIONS before operating. Failure to follow the safety rules and other basic safety precautions may result in serious personal injury. Save these instructions in a safe place and on hand so that they can be read when required. Keep these instructions to assist in future servicing.

---

# FuelWORKS<sup>®</sup>

Solution for Fuel Transfer

## GENERAL SAFETY REGULATIONS



**WARNING:** The warnings, cautions, and instructions discussed in this instruction manual cannot cover all possible conditions or situations that could occur. It must be understood by the operator that common sense and caution are factors that cannot be built into this product, but must be supplied by the operator.

1. Keep the work area clean and dry. Damp or wet work areas can result in injury.
2. Keep children away from work area. Do not allow children to handle this product.
3. Use the right tool for the job. Do not attempt to force small equipment to do the work of larger industrial equipment. There are certain applications for which this equipment was designed. It will do the job better and more safely at the capacity for which it was intended. Do not modify this equipment, and do not use this equipment for a purpose for which it was not intended.
4. Check for damaged parts. Before using this product, carefully check that it will operate properly and perform its intended function. Check for damaged parts and any other conditions that may affect the operation of this product. Replace damaged or worn parts immediately.
5. Do not overreach. Keep proper footing and balance at all times to prevent tripping, falling, back injury, etc.
6. **DO NOT** use the equipment when tired or under the influence of drugs, alcohol, or medication. A moment of inattention while operating this equipment may result in serious personal injury.

## TECHNICAL DETAILS

Item No.	31250571	31250661
Voltage	230V	120V
Frequency	50HZ	60HZ
Power	200W	240W
Max Flow Rate	56LPM	66LPM
Inlet/Outlet	1"	1"

**PUMP:** Electric self-priming rotary vane pump, equipped with by-pass valve, built-in filter

**MOTOR:** Asynchronous motor, single phase, 2-pole, closed type (Protection class IP55), self-ventilating

### OPERATING ENVIRONMENTAL CONDITIONS

- Temperature: Min. -20°C, Max. +60°C
- Relative Humidity: Max. 90%



#### ATTENTION!

The temperature limits shown apply to the pump components and must be respected to avoid possible damage or malfunction.

### ELECTRICAL POWER SUPPLY

- Depending on the model, the AC pump must be supplied by a single-phase alternating current line whose nominal values are shown in the table in Paragraph 2 Electrical specification. The maximum acceptable variations from the electrical parameters are:
- Voltage:  $\pm 5\%$  of the nominal value
- Frequency:  $\pm 2\%$  of the nominal value



#### ATTENTION!

Power from lines with values outside the indicated limits can damage the electrical components.



#### ATTENTION!

Functioning under by-pass conditions is only allowed for brief periods of time (2 minutes maximum).



#### ATTENTION!

Functioning under by-pass conditions is only allowed for brief periods of time (2-3minutes maximum).

### FLUIDS PERMITTED / FLUIDS NOT PERMITTED PERMITTED

Diesel fuel at a viscosity of from 2 to 5 cST (at a temperature of 37°C)  
Minimum Flash point (PM): 55°C

**NOT PERMITTED**

NOT PERMITTED	RELATED DANGER
Gasoline (Petrol)	Fire - explosion
Inflammable liquids with PM < 55 °C	Fire - explosion
Liquids with viscosity > 20 Cst	Motor overload
Water	Oxidation of the pump
Liquid food products	Contamination
Corrosive Chemicals	Corrosion of the pump Injury to people
Solvents	Fire - explosion Damage to gasket seals et Seals

**INSTALLATION****PRELIMINARY INSPECTION**

- Check that the machine has not suffered any damage during transport or storage.
- Clean the inlet and outlet openings, removing any dust or residual packing material.
- Make sure that the motor shaft turns freely.
- Check that the electrical specifications correspond to those shown on the identification plate.

**POSITIONING THE PUMP**

- The pump can be installed in any position (pump axis vertical or horizontal)
- Attach the pump using screws of adequate diameter for the attachment holes provided in the base of the pump

**ATTENTION!**

The motors are not of an anti-explosive type.

Do not install them where inflammable vapors can be present.

**CONNECTING THE HOSE**

- Before connection, make sure that the hoses and the suction tank are free of dirt and thread residue that could damage the pump and its accessories.
- Before connecting the delivery hose, partially fill the pump body with diesel fuel to facilitate priming.

**SUCTION HOSE**

- Minimum recommended nominal diameter: 1"
  - Nominal recommended pressure: 10 bar / 145PSI
- Use hose suitable for functioning under suction pressure

**DELIVERY HOSE**

- Minimum recommended nominal diameter: 3/4"
- Nominal recommended pressure: 10 bar / 145PSI

**ATTENTION**

- It is the installer's responsibility to use tubing with adequate characteristics.
- The use of tubing unsuitable for use with Diesel fuel can damage the pump, injure persons and cause pollution.
- Loosening of the connections (threaded connections, flanging, gasket seals) can cause serious ecological and safety problems.
- Check all the connections after the initial installation and on a daily basis after that. Tighten the connections, if necessary.

## Considerations regarding delivery and suction lines

### DELIVERY

The choice of pump model must be made keeping the characteristics of the system in mind.

The combination of the length of the tubing, the diameter of the tubing, the flow rate of the diesel fuel and the line accessories installed can create back pressure greater than the maximums anticipated such as to cause the (partial) opening of the pump by-pass with the consequent noticeable reduction of the flow rate supplied.

In such cases, to allow correct functioning of the pump, it is necessary to reduce system resistance, using shorter tubing and/or of wider diameter and line accessories with less resistance (e.g., an automatic dispensing nozzle for greater flow rates).

### SUCTION

The pumps are self-priming and characterized by good suction capacity.

During the start-up phase, with an empty suction tube and the pump wetted with fluid, the electric pump unit is capable of suctioning the liquid with a maximum difference in height of 2 meters. It is important to point out that the priming time can be as long as one minute and the presence of an automatic dispensing nozzle on the delivery line prevents the evacuation of air from the installation, and therefore, prevents proper priming.

For this reason, it is always advisable to prime the pump without an automatic delivery nozzle, verifying the proper wetting of the pump. The installation of a foot valve is recommended to prevent the emptying of the suction tube and keep the pump wet. In this way, the pump will subsequently always start up immediately.

When the system is functioning, the pump can work with pressure at the inlet as high as 0.5 bar, beyond which cavitation phenomena can begin, with a consequent loss of flow rate and increase of system noise.

It is very important to keep the suction filters clean because, once clogged, they increase system resistance.

The difference in height between the pump and the fluid level must be kept as small as possible and, at any rate, within the 2 meters anticipated for the priming phase.

If this height is exceeded, it will always be necessary to install a foot valve to allow for the filling of the suction tube and provide tubing of wider diameter. It is recommended that the pump not be installed at a difference in height greater than 3 meters.



### ATTENTION

In the case that the suction tank is higher than the pump, it is advisable to install an anti-siphon valve to prevent accidental diesel fuel leaks.

Measure the installation in order to control the back pressure due to water hammering.

### Daily Use

- If using flexible tubing, attach the ends of the tubing to the tanks. In the absence of an appropriate slot, solidly grasp the delivery tube before beginning dispensing.
- Before starting the pump make sure that the delivery valve is closed (dispensing nozzle or line valve).
- Turn the ON/OFF switch to ON. The by-pass valve allows functioning with the delivery closed for only brief periods.
- Open the delivery valve, solidly grasping the end of the tubing.
- Close the delivery valve to stop dispensing.
- When dispensing is finished, turn off the pump.



## ATTENTION!

Functioning with the delivery closed is only allowed for brief periods (2-3 minutes maximum). After use, make sure the pump is turned off.

Lack of electric power

A lack of electric power, with the consequent accidental stopping of the pump, can be caused by:

- A safety device tripping
- A drop in line voltage

In either case, act as follows:

- Close the delivery valve
- Attach the end of the delivery to the slot provided on the tank
- Turn the ON/OFF switch to the OFF position

## PROBLEMS AND SOLUTIONS

Problem	Possible Cause	Corrective Action
The Motor is not turning	Lack of electric power	Check the electrical connecting
	Rotor jams	Check for possible damage or obstruction of the rotating components
	Motor Problems	Contact the Service Department
The motor turns slowly when starting	Low voltage in the electric power line	Bring the voltage back within the anticipated limits
Low or no flow rate	Low level in the suction tank	Refill the tank
	Foot valve blocked	Clean and/or replace the valve
	Filter clogged	Clean the filter
	Excessive suction pressure	Lower the pump with respect to the level
	High loss of head in the delivery circuit (working with the by-pass open)	Use shorter tubing or of greater diameter
	By-pass valve blocked	Dismantle the valve, clean and/or replace it.
	Air entering the pump or the suction tubing	Check the seals of the Connections
	A narrowing in the suction tubing	Use tubing suitable for working under suction pressure
	Low rotation speed	Check the voltage at the pump. Adjust the voltage and/or use cables of greater cross-section
Increased pump noise	The suction tubing is resting on the bottom of the tank	Raise the tubing
	Cavitation occurring	Reduce suction pressure
	Irregular functioning of the by-pass	Dispense until the air is purged from the circuit
Leakage from the pump body	Air present in the diesel fuel	Verify the suction connection
	Seal Damaged	Check and replace the mechanical seal

## MAINTENANCE

The pumps are designed and constructed to require a minimum of maintenance.

- On a weekly basis, check that the tubing joints have not loosened, to avoid any leakage.
- On a monthly basis, check the pump body and keep it clean of any impurities.
- On a monthly basis, check and keep the pump filter clean and any other filters installed.
- On a monthly basis, check that the electric power supply cables are in good condition.
- Under normal working conditions the noise emission from all models does not exceed the value of 70 db at a distance of 1 meter from the electric pump.

## EXPLODED AND PARTS LIST

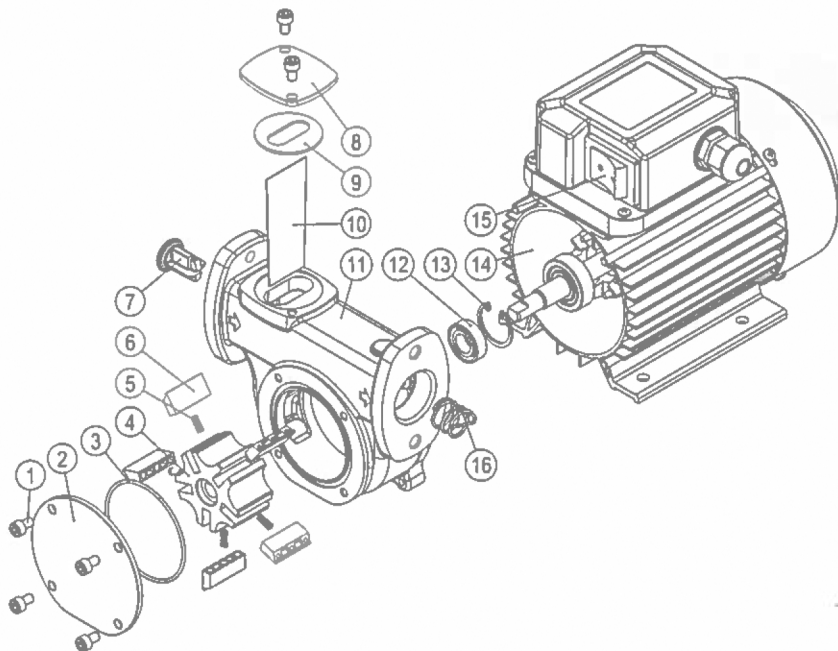

Part No.	Description	Q'ty	Part No.	Description	Q'ty
1	Screw M5×8	6	9	Airproof Rubber	1
2	Front Cover	1	10	Filter	1
3	O-Ring	1	11	Pump Body	1
4	Rotor	1	12	Seal	1
5	Spring	5	13	Spring Collar	1
6	Blade	5	14	Motor	1
7	By Pass Valve	1	15	Switch	1
8	Filter Cover	1	16	By Pass Spring	1



Intradin (Shanghai) Machinery Co., Ltd.  
iti-fluid@intradinchina.com  
www.intradin.com