

HEALY™ 900 SERIES NOZZLE

SERVICE GUIDE

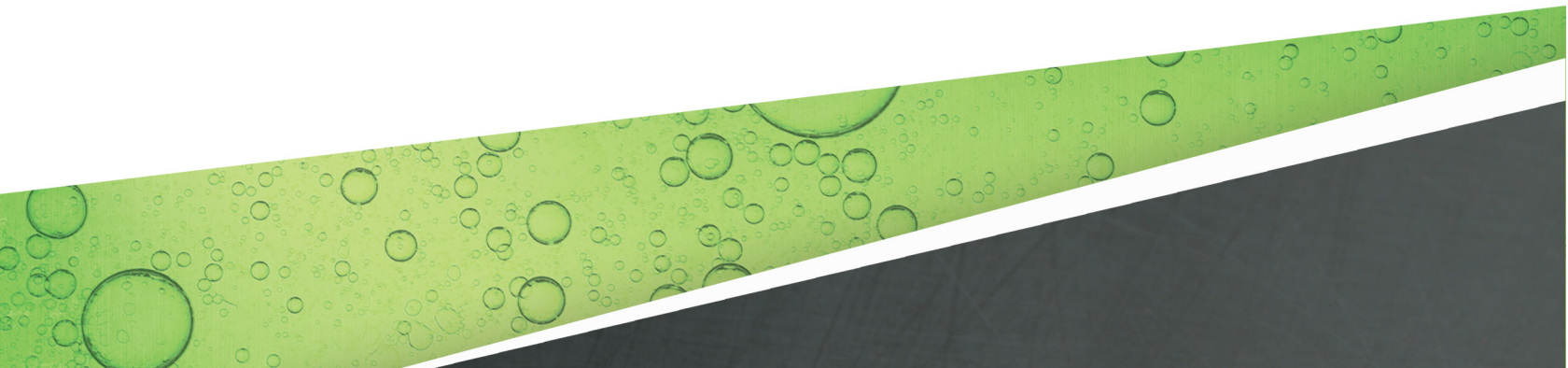

The information in this publication is provided for reference only. While every effort has been made to ensure the reliability and accuracy of the information contained in this manual at the time of printing, we recommend that you refer to "franklinfueling.com" for the most current version of this manual. All product specifications, as well as the information contained in this publication, are subject to change without notice. Franklin Fueling Systems does not assume responsibility and expressly disclaims liability for loss, damage, or expense arising out of, or in any way connected with, installation, operation, use, or maintenance by using this manual. Franklin Fueling Systems assumes no responsibility for any infringement of patents or other rights of third parties that may result from use of this manual or the products. We make no warranty of any kind with regard to this material, including, but not limited to, the implied warranties of merchantability and fitness for a particular purpose.

Copyright © 2016 Franklin Fueling Systems, Madison, WI 53718. All world rights reserved. No part of this publication may be stored in a retrieval system, transmitted, or reproduced in any way, including, but not limited to, photocopy, photograph, magnetic, or other record, without the prior written permission of Franklin Fueling Systems.

For technical assistance, please contact:

Franklin Fueling Systems
3760 Marsh Rd.
Madison, WI 53718
USA

Web: franklinfueling.com

Telephone:

USA and Canada: +1.608.838.8786, +1.800.225.9787

USA and Canada Technical Support: +1.800.984.6266

UK: +44 (0) 1473.243300

Mexico: 001.800.738.7610

France: +33 (0) 1.69.21.41.41

China: +86.10.8565.4566

HEALY is trademark of Franklin Electric Company, Inc.

405201001 r7

Contents

- Introduction1
- Conventions used in this manual1
- Questions and concerns1
- Operating precautions2
- Field repair procedures.....3
- Illustration and replaceable parts.....3
- Replacing the mini-boot4
- Removing the mini-boot.....4
- Installing the new mini-boot4
- Replacing the mini-boot for nozzles with EOR spouts5
- Replacing the spout assembly5
- Installing the new spout assembly5
- Testing the new spout assembly6
- Replacing the scuffguard6
- Replacing the handle cover7
- Replacing the handguard.....7
- Replacing the lever7
- Testing the vapor to liquid ratio.....9
- Test procedure10
- Adjusting the V/L ratio11

Intentionally Blank

Introduction

Conventions used in this manual

This manual includes safety precautions and other important information presented in the following format:

NOTE: This provides helpful supplementary information.

IMPORTANT: This provides instructions to avoid damaging hardware or a potential hazard to the environment, for example: fuel leakage from equipment that could harm the environment.

⚠ CAUTION: This indicates a potentially hazardous situation that could result in minor or moderate injury if not avoided. This may also be used to alert against unsafe practices.

⚠ WARNING: This indicates a potentially hazardous situation that could result in severe injury or death if not avoided.

⚠ DANGER: This indicates an imminently hazardous situation that will result in death if not avoided.

Questions and concerns

In case of emergency, follow the procedures established by your facility. If you have questions or concerns about safety or need assistance, use the information below to contact Franklin Fueling Systems:

Web: franklinfueling.com

Telephone:

USA and Canada: +1.608.838.8786, +1.800.225.9787

USA Technical Support: 1.800.984.6266

UK: +44 (0) 1473.243300

Mexico: 001.800.738.7610

France: +33 (0) 1.69.21.41.41

China: +86.10.8565.4566

Operating precautions

Franklin Fueling Systems (FFS) equipment is designed to be installed in areas where volatile liquids such as gasoline and diesel fuel are present. Working in such a hazardous environment presents a risk of severe injury or death if you do not follow standard industry practices and the instructions in this manual. Before you work with or install the equipment covered in this manual, or any related equipment, read this entire manual, particularly the following precautions:

⚠ CAUTION: Use only original FFS parts. Substituting non-FFS parts could cause the device to fail, which could create a hazardous condition and/or harm the environment.

⚠ WARNING: Follow all codes that govern how you install and service this product and the entire system. Always lock out and tag electrical circuit breakers while installing or servicing this equipment and related equipment. A potentially lethal electrical shock hazard and the possibility of an explosion or fire from a spark can result if the electrical circuit breakers are accidentally turned on while you are installing or servicing this product. Refer to this manual (and documentation for related equipment) for complete installation and safety information.

⚠ WARNING: Follow all federal, state, and local laws governing the installation of this product and its associated systems. When no other regulations apply, follow NFPA codes 30, 30A, and 70 from the National Fire Protection Association. Failure to follow these codes could result in severe injury, death, serious property damage, and/or environmental contamination.

⚠ WARNING: Always secure the work area from moving vehicles by using a service truck (or some other vehicle) to block access to the work area.

⚠ WARNING: Discharge static electricity from the product before you install it, and make sure it is properly grounded while in service.

⚠ WARNING: Make sure you check the installation location for potential ignition sources such as radio waves, ionizing radiation, and ultrasound sonic waves. If you identify any potential ignition sources, you must make sure safety measures are implemented.

Field repair procedures

Only an FFS certified technician can service problems discovered while conducting the weekly or quarterly inspection and testing. Provided that there are no other local district requirements, a GDF owner/operator can remove and install nozzles, curb hoses, breakaways, flow limiters, and whip hoses without a manufacturer certification. Additional certifications may be required in accordance with local district requirements.

Illustration and replaceable parts

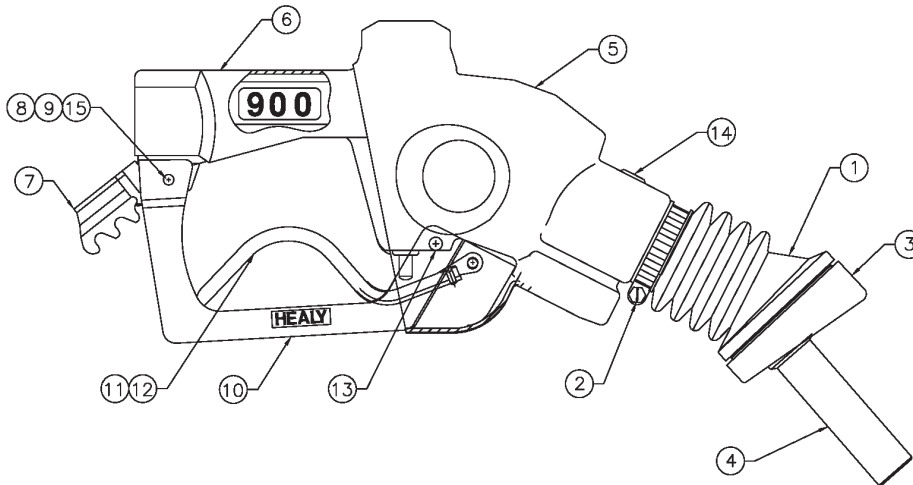

| Image # | Part Number | Description |
|---------|--|---|
| 1 | 405219906 | 900 Mini-Boot Assembly (for use with EOR spout) |
| 2 | 640956 | Mini-Boot Clamp |
| 3 | 279A | Face Seal Assembly with Wire |
| 4 | 405220901-EOR | Spout Assembly (Includes 900 mini-boot) |
| 5 | (Contact FFS Technical Support) | Scuffguard, Assorted Colors |
| 6 | 469 | Handle Cover |
| 7 | 6238 (3-position) or 6238-2 (2-position) | Hold Open Clip* |
| 8 | 239-L | Rear Guard Pin |
| 9 | 6249 | Spring* |
| 10 | 6358 | Handguard |
| 11 | 235-C | Lever Cover |
| 12 | 6130-4 | Lever Assembly* |
| 13 | 219 | Front Guard Rivet* |
| 14 | 6102A | Spout Screw & O-ring |
| 15 | 240SS | Pal Nut |

* Order HEALY™ part number Z057 or Z058 Hold-Open Clip Kit. (This includes HEALY™ part numbers: 6238 (Z057) or 6238-2 (Z058) Hold-Open Clip, 239-L Rear Guard Pin, 6249 Spring, 6130-4 Lever Assembly, 240SS Pal Nut, and 219 Front Guard Rivet.)

Replacing the mini-boot

NOTE: Replacement boots for non-EOR spouts are no longer available. Instead, please order EOR Spout Assembly 405220901-EOR.

Replacing the mini-boot for nozzles with EOR spouts

The Mini-Boot Assembly for nozzles with the Enhanced ORVR Recognition (EOR) spout has part number 405219906. As shown below, the EOR spout has an elongated lower anchor, and the mini-boot has an “E” on the push plate inside the boot.

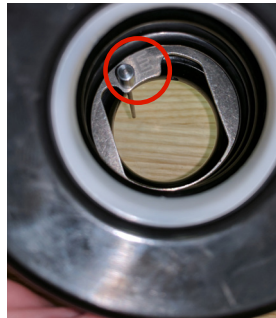

Removing the mini-boot

1. To remove the old mini-boot, unscrew and remove the mini-boot clamp. (See image reference 2 in “Illustration and replaceable parts.”)
2. Grip the mini-boot and rotate back and forth a maximum of 5 degrees in each direction while gently pulling to separate the mini-boot from the nozzle.

Installing the new mini-boot

NOTE: Heating the mini-boot in water softens the material, making it easier to install.

1. Use a push rod checking tool (.050 hex wrench or 1/16" drill bit) to verify that a clear hole condition exists in the push rod hole of the spout body before proceeding.
2. Align the push rod extending from the nozzle end of the boot with the 1/16" hole in the spout body, and align the 3/16" hole in the mini-boot with the 3/16" pin on the spout body.

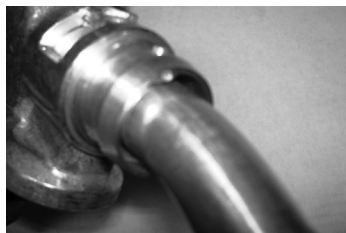

3. Start the push rod into the 1/16" hole and slide the boot axially into engagement with the spout body and the boot location pin while limiting angular rotation of the boot to 5 degrees in each direction to avoid bending the push rod.

4. Install the mini-boot clamp and tighten securely. Verify that the HEALY™ logo on the mini-boot is aligned with the top center of the nozzle.
5. Verify that the nozzle will not dispense fuel when the dispenser is authorized (ready to dispense fuel) and the boot is in a free state by holding the nozzle into an approved container (do not compress the mini-boot in any manner) and actuate the nozzle. No fuel should dispense. If fuel does not dispense, proceed to the next step. Any nozzle that dispenses fuel with the mini-boot in a free state condition must be repaired or replaced.
6. Verify that the nozzle will dispense fuel when the dispenser is authorized and the nozzle spout is inserted into a vehicle fill-pipe to a position 1/8" short of locking the spout anchor ring over the rim of the fill-pipe opening or manually held back while dispensing into an approved container. Any nozzle that does not dispense fuel must be repaired or replaced.

Replacing the spout

NOTE: The following procedures require the Spout Assembly.

1. Use a Phillips screwdriver to remove the # 8 pan head spout screw and O-ring that hold the spout in place. (See image reference 14 in "Illustration and replaceable parts.")
2. With the screw removed, using a maximum twisting motion of 15 degrees in each direction, separate the nozzle body and the spout. Be sure that the three O-rings from the discarded spout assembly do not remain in the nozzle body. There is a fourth O-ring, furthest from the opening that remains inside the nozzle. Leave this O-ring in place.

Installing the new spout

1. Install the new, pre-lubed O-rings (included with the Spout Assembly) on the new spout assembly.
2. Carefully insert the spout into the nozzle, lightly pushing together until the spout aligns itself and resistance is felt. Using a maximum twisting motion of 15 degrees and light pressure, slide the pieces together, seating the o-rings and aligning the screw threads in the spout housing with the hole in the nozzle casting.
3. Install the new # 8 panhead spout screw and O-Ring, and tighten securely to 12 inch/lbs.
4. Follow steps 5 and 6 in "Installing the new mini-boot" to test nozzle operation.

Testing the new spout assembly

IMPORTANT: All spout replacements must be tested to ensure the installation has been completed correctly.

1. Dispense product into a container deep enough to cover the small hole near the tip of the spout and verify that the dispensing rate is between 6.0–10.0 gpm with the nozzle lever held in the full open (handheld) position. While dispensing, with the nozzle lever held in the full open (handheld) position, immerse the spout until the hole is covered. If shutoff does not occur, turn off the dispenser, remove the spout, and check the o-rings. Replace the O-rings (part number 6206-OR) as necessary and repeat step 4 of “Installing the new spout assembly,” and then repeat this step. If shutoff does occur, go to the next step.

NOTE: If repeated attempts to repair nozzle does not result in successful shut off, replace the nozzle. Contact FFS Technical Support for assistance.

2. Repeat the previous step twice (for a total of three tests) to ensure that the auto shutoff feature is working properly. There should be no hesitation to the shutoff; it should be quick and positive. If shutoff tests are successful, the nozzle can be put back into service. If either additional shutoff test fails, turn off the dispenser, remove the spout, and check the o-rings.
3. Replace the o-rings as necessary (part number 6206-OR). Repeat step 4 of “Installing the new spout assembly,” and then repeat the previous two steps.

NOTE: If repeated attempts to repair the nozzle does not result in successful shut off, take the nozzle out of service and replace it.

Replacing the scuffguard

NOTE: The part number needed for the following procedure depends on the scuffguard color. Contact FFS Technical Support for the correct part number.

1. Use the instructions in “Removing the mini-boot” to remove the mini-boot.
2. Slide a long screwdriver under the scuffguard in the area of the main valve cap nut on the top of the nozzle. (See image reference 5 in “Illustration and replaceable parts.”)
3. Pry upward to clear the top of the main valve cap, and then pull steadily toward the spout to remove.
4. Installation is the reverse of this method. It works best with the butt of the nozzle held in a vise. In cold weather the scuffguard may not be pliable enough to use the above method, carefully (do not damage the nozzle) cut the old scuffguard off with a knife and replace it with a new, warmed, scuffguard by using the reverse of the previous step.
5. Use the instructions in “Installing the new mini-boot” to install the mini-boot and test nozzle operation.

Replacing the handle cover

NOTE: The following procedure requires the Handle Cover (part number 469).

1. Grasp the lower edges of the handle cover, and pull the cover off with an upward motion. (See image reference 6 in “Illustration and replaceable parts.”)
2. Installation is the reverse of this procedure. Be sure the pointed wings on the front of the cover are slid under the scuffguard.

Replacing the handguard

NOTE: The following procedure requires the Handguard (part number 6358).

1. This is best done with the nozzle detached from the hose. The front and rear guard pins must be removed. Back up the head side of the pin with a suitable socket and drive out the guard pins using a 3/32" drive pin punch or equivalent. The spring-loaded hold-open clip will pop out when the rear pin is removed. Be sure to observe the orientation of the spring so it can be properly reinstalled.
2. Remove the handguard carefully. (See image reference 10 in “Illustration and replaceable parts.”) The lever will drop down, and the lever pivot pin will be free and could possibly slide out. Place the new handguard in position and install a new front guard pin through the handguard. (See image reference 13 in “Illustration and replaceable parts.”) Do not peen at this time.
3. Position the hold-open clip over the handguard. (See image reference 7 in “Illustration and replaceable parts.”) Insert a new rear guard pin through one ear of the clip, handguard and approximately 1/8" through the casting. (See image reference 8 in “Illustration and replaceable parts.”) Slide the coil spring into position with the “hook” on the hold-open clip. (See image reference 9 in “Illustration and replaceable parts.”) Push in the spring so the pin passes through the coil and into the other ears on the casting, handguard, and clip. Be sure the hold-open clip is installed properly before peening-over the free ends of the two pins.

Replacing the lever

NOTE: The following procedure requires the Lever Assembly (part number 6130-4).

1. Use the instructions in “Replacing the handguard” to remove the handguard and expose the lever. There is a washer around the plunger under the lever. Observe how these are installed and be sure to reuse them with the new lever.
2. With the lever released, the white plunger will pull back towards the casting and make it difficult to reinstall the pin on a new lever. Use a small screwdriver to reach through one mounting hole in the new lever and engage the hole in the plunger. Push the blade through the plunger, align the two holes, insert the pin, and remove the screwdriver to retain the lever.
3. Use the instructions in “Replacing the handguard” to reinstall the handguard.

Intentionally blank

Testing the vapor to liquid ratio

You must use an adaptor to determine the vapor to liquid (V/L) volume ration on the HEALY™ Model 900 Series Vapor Assist Nozzle. The adaptor is required to perform a V/L ratio test with Exhibit 5 of either Executive Order VR-201 or VR-202. A V/L ratio between 0.95 and 1.15 is required (at a flow rate between 6.0 gpm to 10.0 gpm).

There are three adaptors you can use to test the V/L ratio. Depending on the spout with which the nozzle you are testing is equipped, you can use the HEALY™ Adaptor Model 8034-1, the HEALY™ Adaptor Model 8034-3, or the Triangle Gold Adaptor. See the table below for correct combinations.

| Nozzle | HEALY™ Adaptor Model 8034-1 | HEALY™ Adaptor Model 8034-3 | Triangle Gold Adaptor |
|---------------------------------|-----------------------------|-----------------------------|-----------------------|
| HEALY™ Original Model 900 | X | X | X |
| HEALY™ Model 900 with EOR Spout | | X | X |

Inspect the spout seal O-ring before you do a test. Any cuts or tears will allow air to be ingested and give an inaccurate reading.

NOTE: Motor oil (any weight) is acceptable for lubricating the O-Ring. Contact FFS Technical Support with any questions about other lubricants you can use when you do this test.

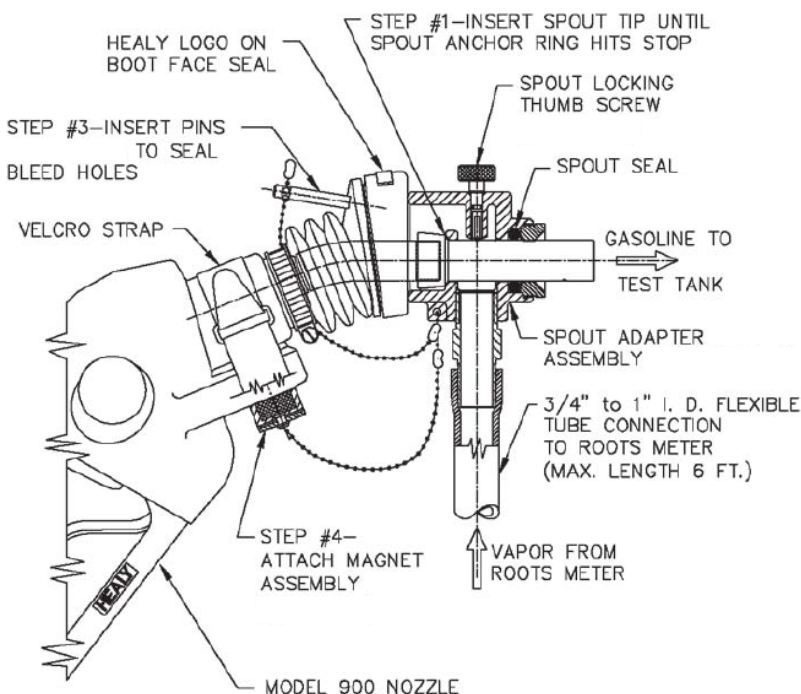

Test procedure

NOTE: Conduct all pre-tests and testing in accordance with Exhibit 5 of either Executive Order VR-201 or VR-202.

1. Slide the V/L adaptor over the spout tip and compress the boot until the spout anchor ring contacts stop in the V/L adaptor.
2. Hold the V/L adaptor in contact with the spout anchor ring and hand tighten thumbscrew to secure adaptor. The thumbscrew and HEALY™ logo on top of the nozzle boot face seal must be in vertical alignment to imitate fueling an unleaded vehicle.
3. Insert pins to seal the two bleed holes in the boot (directly behind the face seal assembly).
4. Hold the magnet assembly against the vinyl scuffguard directly below ORVR sensor housing and secure in place with the velcro strap as shown below. A vacuum level of 0.1" wc may activate the ORVR sensor, causing a substantial decrease (error) in the V/L ratio. The magnet locks out the ORVR sensor to avoid false results in V/L testing.

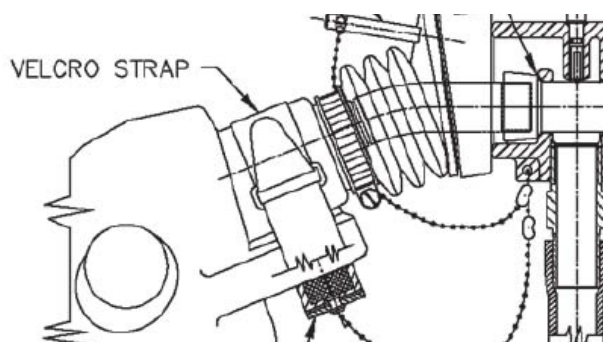

5. Check the strength of the magnet before fastening it to the nozzle. The magnet should be capable of holding about two pounds of weight.

NOTE: A typical gas cylinder safety cap weighs about 2 lbs.

6. Proceed with V/L test. If the grade point tested is not within the limit of the executive order, use the procedure in "Adjusting the V/L ratio" to adjust the V/L ratio.

NOTE: If more than one nozzle share vacuum plumbing with the nozzle being tested, one troubleshooting method for a low V/L ratio is to seal all nozzles other than the nozzle being tested, using plastic bags and tape or rubber bands. If leaks in the nozzles/check valves served by a common vacuum pump cause the bags to deflate, the low V/L ratio may have been caused by a leak through an idle nozzle during the test. The V/L test to verify compliance, however, shall be conducted without "bagging" any of the nozzles.

7. Remove the seal pins and magnet assembly, loosen thumbscrew, and remove the V/L adaptor from the nozzle.

Adjusting the V/L ratio

1. Remove, or pull forward, the scuffguard from the nozzle body.
2. Move the spout of the nozzle so that it faces to your left, and locate the vapor flow control valve on the side of the nozzle body. Do not remove the cover assembly.

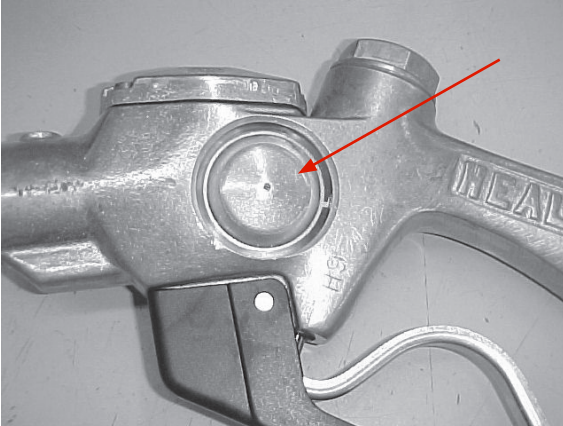

3. Locate the opening in the center on the cover of the vapor flow control valve. Insert a .050 hex key into the center opening of the vapor valve cover assembly.

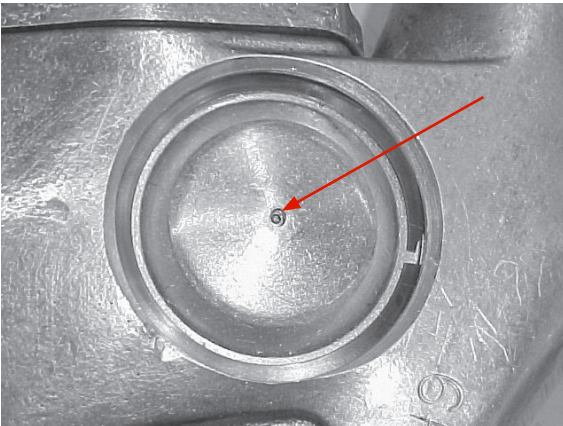

4. Turn the hex key clockwise to increase the V/L reading or counter-clockwise to decrease the V/L reading.
5. After making adjustments, the nozzle must be retested as specified in Exhibit 5, Section 7, of either Executive Order VR-201 or VR-202, for V/L readings. Repeat testing until the nozzle V/L is between 0.95 and 1.15.



Franklin Fueling Systems



A Franklin Fueling Systems Brand

405201001 r7

