

### Hex Nylon Insert Locknut (NE), Grade N2, Zinc

The information below lists the required dimensional, chemical and physical characteristics of the products in this purchase order. If This product standard contains the required dimensional, mechanical, performance, and chemical characteristics of the products shown in this purchase order (as applicable to the product). Unless specified below, current revisions of national or international standards shall be applicable as of the date of Fastenal's purchase order and must be adhered to in their entirety. If the order received does not meet these requirements, corrective action may be issued which could jeopardize your status as an approved supplier to Fastenal.

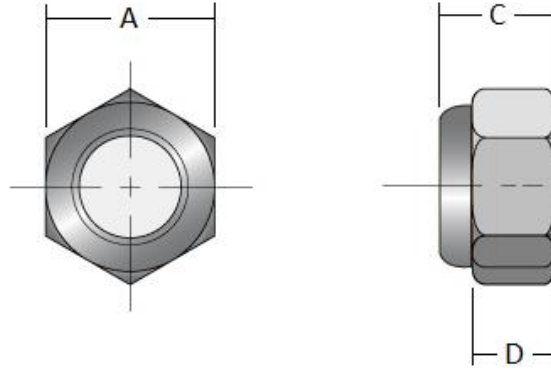

Nominal Size	C		A		D
	Thickness		Width Across Flats		Hex Height
	Max.	Min.	Max.	Min.	Min.
1/4	.328	.298	.439	.430	.225
5/16	.359	.329	.502	.489	.250
3/8	.468	.438	.564	.551	.335
7/16	.468	.438	.627	.616	.324
1/2	.609	.579	.752	.736	.464
9/16	.656	.626	.877	.861	.469
5/8	.765	.735	.940	.922	.593
3/4	.890	.860	1.064	1.052	.742
7/8	.999	.969	1.252	1.239	.790
1	1.078	1.016	1.440	1.427	.825
1 1/8	1.203	1.141	1.627	1.614	.930
1 1/4	1.422	1.360	1.815	1.801	1.125
1 3/8	1.609	1.547	2.008	1.973	1.282
1 1/2	1.640	1.578	2.197	2.159	1.313

**RECORD OF REVISION CHANGES TO THIS DOCUMENT ARE LOCATED ON THE LAST PAGE**

Page 2 of 2	<b>Fastenal Product Standard</b>	REV-05
Date: December 22, 2021	<b>FASTENAL</b>	NYLK.NE.N2.Z

Specification Requirements: Unless otherwise specified, all applicable requirements shall be in accordance with ASME B18.16.6

- Dimensions: ASME B18.16.6
- Material: Grade N2 per ASME B18.16.6  
Nylon 6/6 material shall be in compliance with current RoHS European Union Directive
- Mechanical: Grade N2 per ASME B18.16.6
- Performance: ASME B18.16.6
- Threads: ASME B1.1, UNC, UNS & UNF, Class 2B
- Product Marking: NOTE: The marking requirement of ASME B18.16.6 will not be required
- Finish: Fe/Zn 3AN per ASTM F1941/F1941M

#### Revision Level Changes to this Document

Document Name	Revision Level	Revision Date	Rationale for Revision
NYLK.NE.N2.Z	05	12/22/2021	Added UNS to thread requirement and updated format.

The rationale above may not include all of the changes within each revision. A complete review of the Fastenal Product Standard is required.