

FEATURES:

- STEEL T-FRAME CONSTRUCTION
- 3/8" REINFORCED DIAMOND PLATE STEEL COVER WITH H-20 TRUCK LOAD RATING
- TWO (2) RECESSED STEEL HANDLE
- 14 GA. CARBON STEEL SKIRT
- ALL STEEL COATED WITH A RUST PREVENTATIVE PAINT
- CHANNEL-STYLE CONCRETE ANCHOR
- MADE IN USA

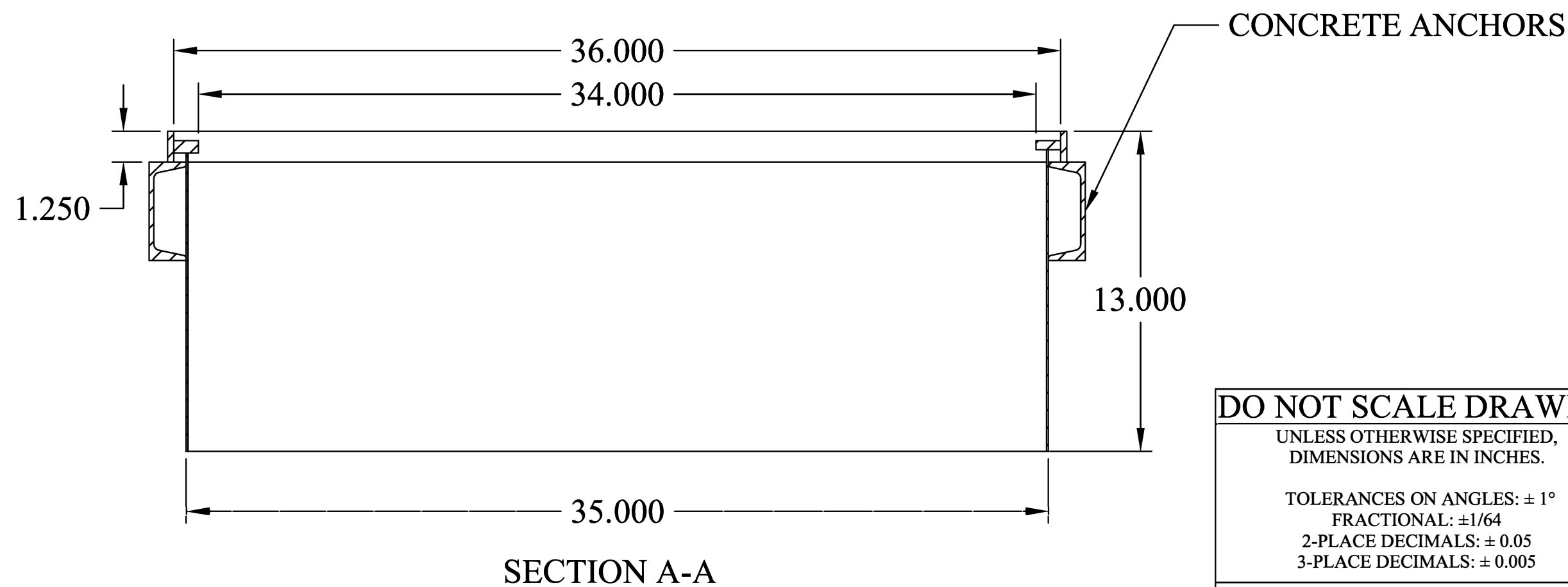
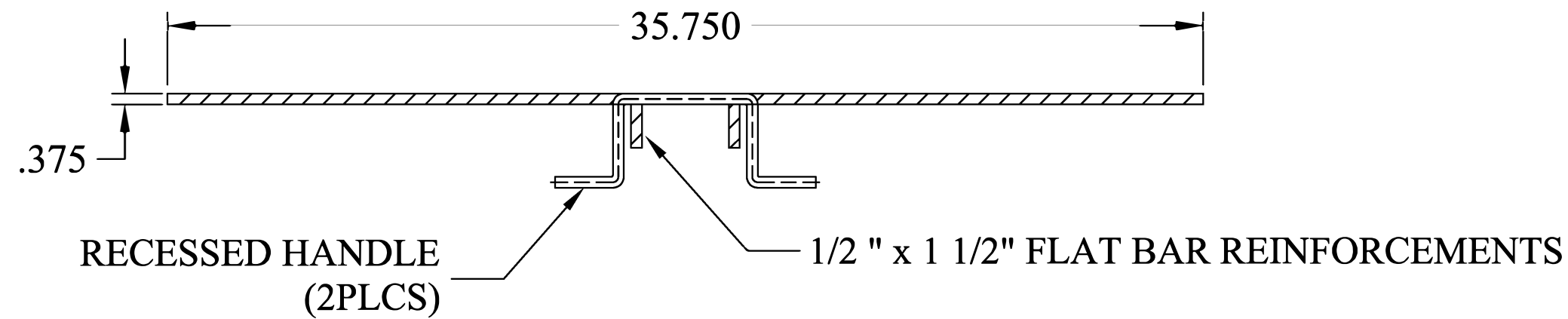

John M. Ellsworth Co., Inc.
 P.O. Box 240072 | 800-333-3331 PHONE
 8700 West Bradley Road | info@jmesales.com E-MAIL
 Milwaukee, WI 53224 | www.JMESales.com WEB

DO NOT SCALE DRAWING

UNLESS OTHERWISE SPECIFIED,
DIMENSIONS ARE IN INCHES.

TOLERANCES ON ANGLES: ± 1°
 FRACTIONAL: ± 1/64
 2-PLACE DECIMALS: ± 0.05
 3-PLACE DECIMALS: ± 0.005

THIRD ANGLE PROJECTION

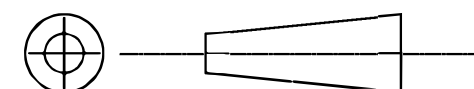

DESCRIPTION
360 HD

SIZE C	SCALE NTS	DWG. NO D101518-3	C.REV -	REV 1
DRAWN BY		DATE 10/15/18	SHT 1 OF 1	