

ALL DIMENSIONS ARE IN MM
DO NOT SCALE THE DRAWING

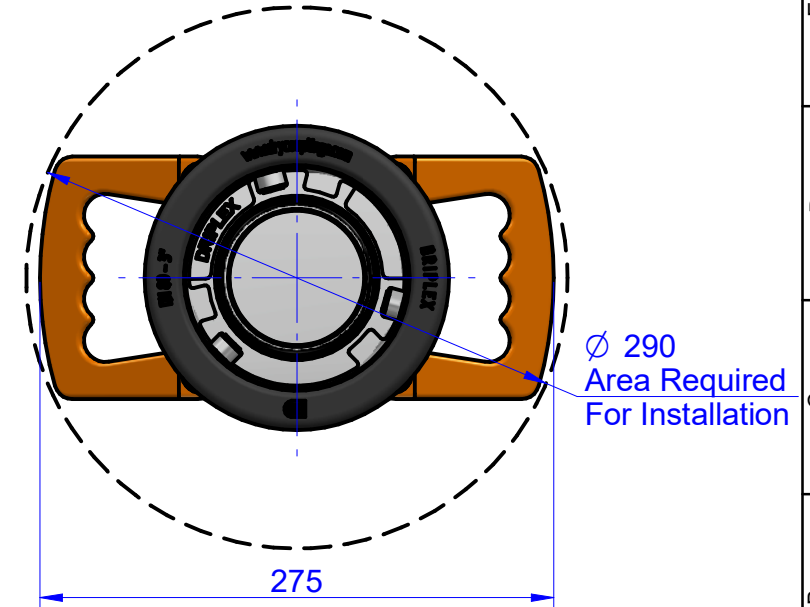
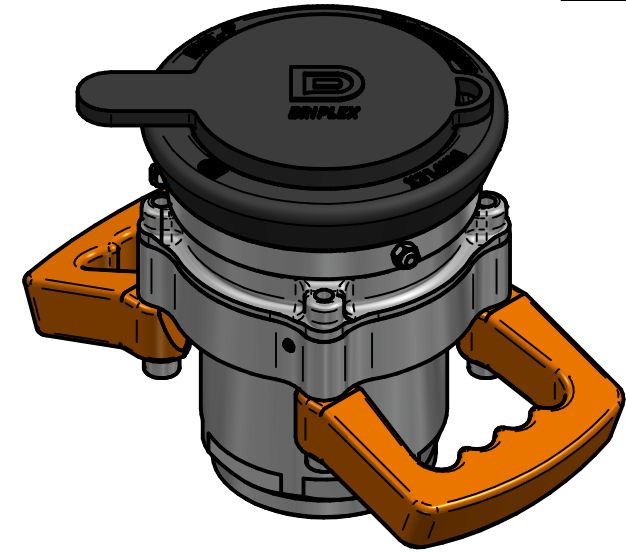
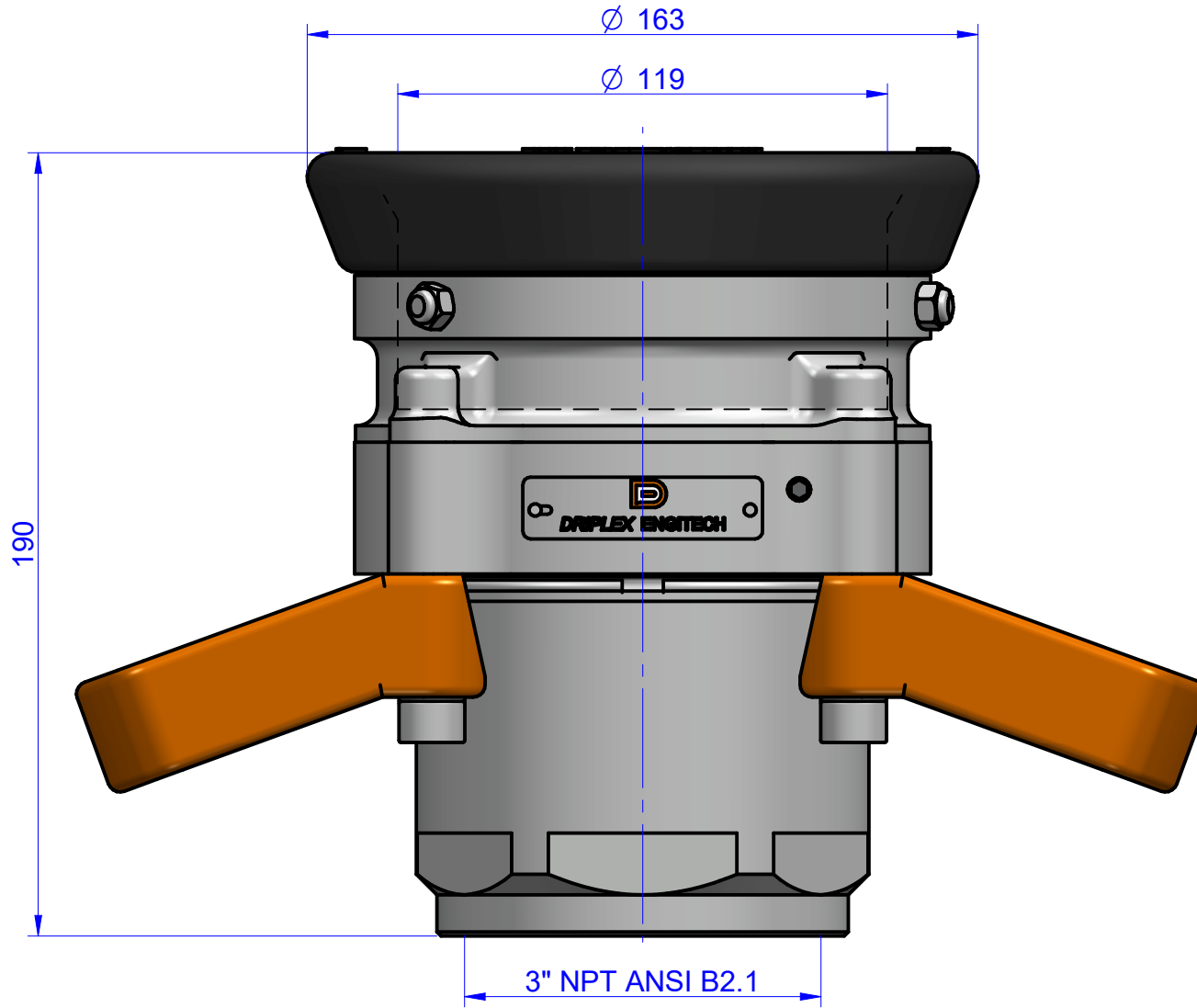

Weight : 9 kg
Working Pressure : 25 bar
Testing Pressure : 37.5 bar

INSTRUCTION :-
1) All unspecified sharp edges to be 0.2X45° Chf..
2) All HOLES & PCD maintain within tolerance $\text{H}0.03$ $\text{L}0.02$
3) Please refer general tolerance wherever tolerance not mentioned.
4) All finished dimension to be maintained after surface treatment.

NOTE :-
HEAT-TREATMENT :- N.A.
SURFACE-TREATMENT :-N.A.

QTY.-: 01 No.
General Tolerance
For Machining : ISO 2768- mK
weldment: ISO 13920-AE

		DRIPLEX ENGITECH	
		COUPLING :- 3H-SV-8-1-0	
TITLE :-		3" DDC HU ASSEMBLY	
DRG.NO :- 3H-SV-8-1-0		MAT. :- STAINLESS STEEL	

REV.	DESCRIPTION	INFORMED BY	DATE	REVISION BY