

**Stainless steel steam, compressed air and gas filter housing.**

Donaldson's P-EG filter housings are designed for purification of compressed air, technical gases and steam in the chemical, electronic, and food and beverage industries.

P-EG filter housings offer:

- Versatile 304 stainless steel design with NPT or ANSI flange connections in various sizes to fit most air, gas and steam applications
- A broad selection of elements for culinary steam, compressed air coalescence and sterile air filtration
- MTRs available upon request
- Gas capacity up to 12,700 scfm at 100 psig
- Steam capacity up to 17,100 lbs/hr at 50 psig
- Design specifications that are customizable upon request



**P-EG**

**SPECIFICATIONS**

Model	Housing Material	Gasket	Pressure and Temp	I/O Connection Size	Int. Surface Finish	Vent/Drain Connection	Element	FNPT Part Number	Flange Part Number	
0006	304 SS	EPDM	232 psig @ 302°F	1/4"	Pickled and Passivated to RA 63	1/2" NPT, plugs provided	UF, 03/10, Qty 1	AG1252538	N/A	
0009				3/8"			UF, 04/10, Qty 1	AG1252539	N/A	
0012				1/2"			UF, 04/25, Qty 1	AG1252540	N/A	
0018				3/4"			UF, 05/20, Qty 1	AG1252541	N/A	
0027				1"			UF, 05/25, Qty 1	AG1252542	AG1252550	
0036				1-1/4"			UF, 07/25, Qty 1	AG1252543	AG1252551	
0048				1-1/2"			UF, 07/30, Qty 1	AG1252544	AG1252552	
0072				2"			UF, 10/30, Qty 1	AG1252545	AG1252553	
0108				2"			UF, 15/30, Qty 1	AG1252546	AG1252554	
0144				2-1/2"			UF, 20/30, Qty 1	AG1252547	AG1252555	
0192				3"			UF, 30/30, Qty 1	AG1252548	AG1252556	
0288				3"			174 psig @ 302°F	UF, 30/50, Qty 1	AG1252549	AG1252557
0432				4"			150 psig @ 450°F	UF, 20/30, Qty 3	N/A	AG1081301
0576				UF, 30/30, Qty 3				N/A	AG1081401	
0768				UF, 30/30, Qty 4				N/A	AG1081501	
1152	UF, 30/30, Qty 6	N/A	AG1081601							
1536	UF, 30/30, Qty 8	N/A	AG1081701							
1920	UF, 30/30, Qty 10	N/A	AG1081801							

## DIMENSIONS

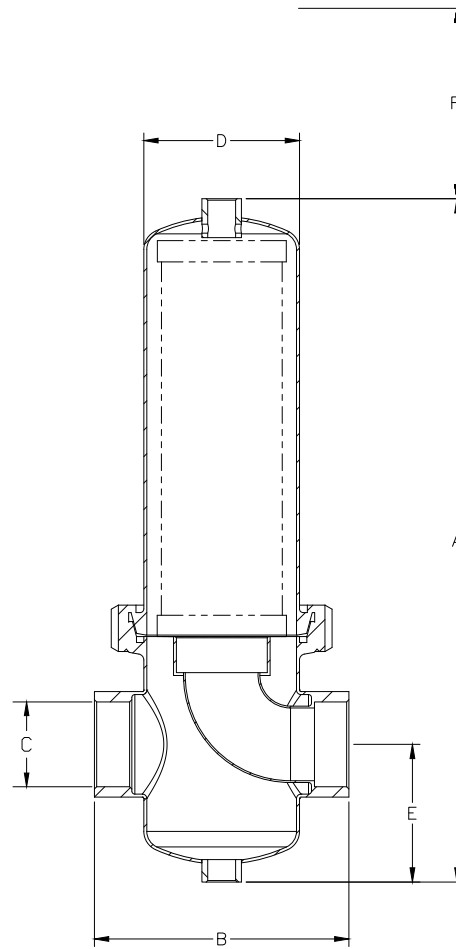

With NPT thread connection

Size	Volume (gal)	Weight* (lbs)	Dimensions (inches)						Element	FNPT Part Number
			A	B ± .125	C	D	E	F		
0006	0.1	4	8.15	4.13	1/4	2.76	2.00	4.25	UF, 03/10, Qty 1	AG1252538
0009	0.2	4.5	9.27	4.13	3/8	2.76	2.00	5.50	UF, 04/10, Qty 1	AG1252539
0012	0.2	4.5	9.27	4.25	1/2	2.76	2.00	5.50	UF, 04/25, Qty 1	AG1252540
0018	0.2	4.5	10.25	4.92	3/4	2.76	2.00	6.50	UF, 05/20, Qty 1	AG1252541
0027	0.3	6	11.26	4.92	1	3.35	2.72	6.50	UF, 05/25, Qty 1	AG1252542
0036	0.3	7	13.31	5.51	1-1/4	3.35	2.76	11.00	UF, 07/25, Qty 1	AG1252543
0048	0.6	9	14.91	6.69	1-1/2	4.09	3.60	11.50	UF, 07/30, Qty 1	AG1252544
0072	0.9	11.5	17.97	6.69	2	4.09	3.62	14.50	UF, 10/30, Qty 1	AG1252545
0108	1.1	12.5	22.89	6.69	2	4.09	3.60	19.50	UF, 15/30, Qty 1	AG1252546
0144	2.1	19.5	28.68	8.15	2-1/2	5.08	3.98	25.00	UF, 20/30, Qty 1	AG1252547
0192	2.9	24.5	38.96	8.15	3	5.08	4.11	35.00	UF, 30/30, Qty 1	AG1252548
0288	4.4	32.5	40.00	9.45	3	6.06	4.32	35.69	UF, 30/50, Qty 1	AG1252549

\* Without filter element

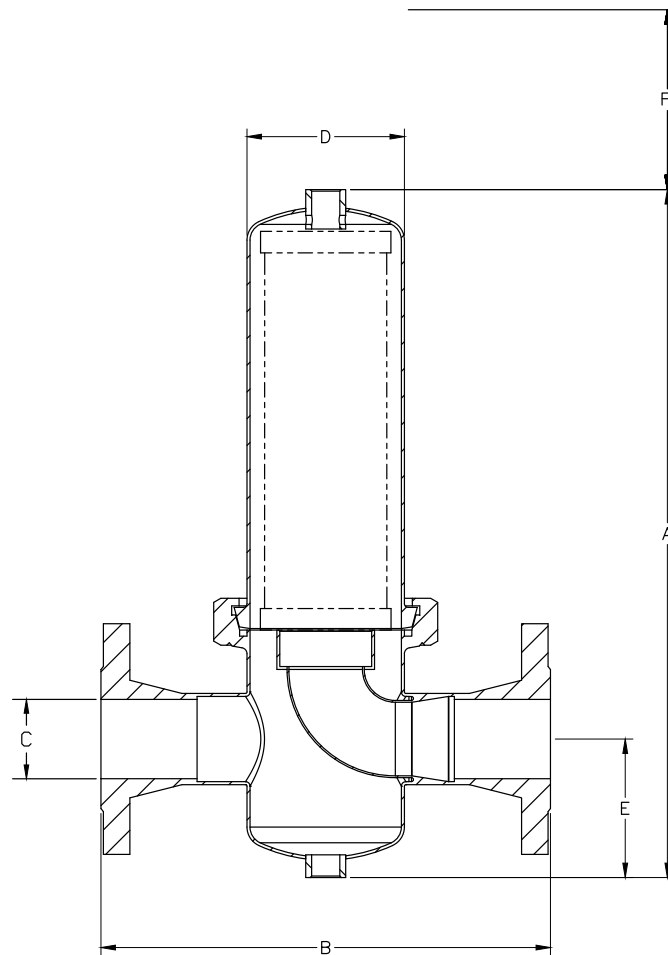

With ANSI Class 150 flange connection

Size	Volume (gal)	Weight* (lbs)	Dimensions (inches)						Element	Flange Part Number
			A	B ± .125	C**	D	E	F		
0027	0.3	11.00	11.24	9.69	1.00	3.35	2.66	6.50	UF, 05/25, Qty 1	AG1252550
0036	0.3	14.00	13.31	10.02	1.25	3.35	2.76	8.50	UF, 07/25, Qty 1	AG1252551
0048	0.6	17.00	14.92	11.57	1.50	4.09	3.58	8.50	UF, 07/30, Qty 1	AG1252552
0072	0.9	22.50	17.89	11.69	2.00	4.09	3.60	11.50	UF, 10/30, Qty 1	AG1252553
0108	1.1	22.78	22.89	11.69	2.00	4.09	3.58	16.50	UF, 15/30, Qty 1	AG1252554
0144	2.1	40.00	28.59	13.02	2.50	5.08	3.94	21.50	UF, 20/30, Qty 1	AG1252555
0192	2.9	45.50	38.94	13.02	3.00	5.08	4.11	31.50	UF, 30/30, Qty 1	AG1252556
0288	4.4	57.50	40.02	14.95	3.00	6.06	4.34	32.50	UF, 30/50, Qty 1	AG1252557

\* Without filter element  
 \*\* 150 lbs ANSI B16.5

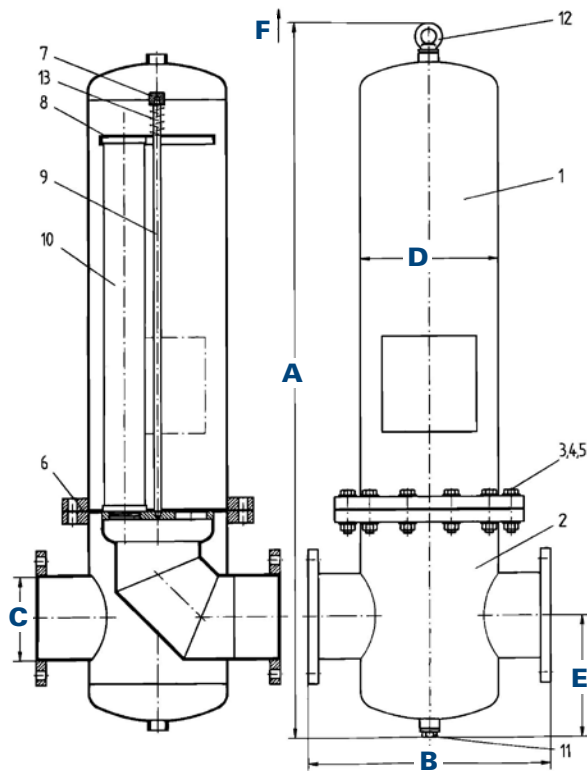

Multi-element with ANSI flange connection

No.	Description
1	Upper housing bowl
2	Lower housing bowl
3	Hex bolt
4	Washer
5	Nut
6	Gasket
7	Hold-down nut
8	Hold-down plate
9	Tie rod
10	Filter element
11	Plug
12	Lifting lugs
13	Spring

Size	Volume (gal)	Weight* (lbs)	Dimensions (inches)						Element	Flange Part Number
			A	B (± .125)	C**	D	E	F		
0432	9.5	140	36.66	16.14	4	8.62	7.25	23	UF, 20/30, Qty 3	AG1081301
0576	11.9	183	46.66	16.14	4	8.62	7.25	33	UF, 30/30, Qty 3	AG1081401
0768	20.3	220	53.13	18.90	6	10.75	9.00	33	UF, 30/30, Qty 4	AG1081501
1152	29.1	338	54.79	21.26	6	12.75	8.82	33	UF, 30/30, Qty 6	AG1081601
1536	50.2	628	62.63	26.00	8	16.0	15.82	33	UF, 30/30, Qty 8	AG1081701
1920	50.2	628	60.50	25.98	8	16.0	13.87	33	UF, 30/30, Qty 10	AG1081801

\* Without filter element  
 \*\* 150 lbs ANSI B16.5

Registered:



**Important Notice**

Many factors beyond the control of Donaldson can affect the use and performance of Donaldson products in a particular application, including the conditions under which the product is used. Since these factors are uniquely within the user's knowledge and control, it is essential the user evaluate the products to determine whether the product is fit for the particular purpose and suitable for the user's application. All products, specifications, availability and data are subject to change without notice, and may vary by region or country.

**Donaldson Company, Inc.**  
 Minneapolis, MN

[donaldson.com](http://donaldson.com)  
[shop.donaldson.com](http://shop.donaldson.com)

**Australasia** 61-02-4350-2066  
[marketing.australia@donaldson.com](mailto:marketing.australia@donaldson.com)

**Brazil** 55-11-4894-6035  
[vendas.brasil@donaldson.com](mailto:vendas.brasil@donaldson.com)

**China** 86-400-921-7032  
[info.cn@donaldson.com](mailto:info.cn@donaldson.com)

**EMEA** 49-2129-569-0  
[cap-europe@donaldson.com](mailto:cap-europe@donaldson.com)

**India** 91-124-4807-400  
[indiaenquiries@donaldson.com](mailto:indiaenquiries@donaldson.com)

**Japan** 81-42-540-4123  
[ndl-ultrafilter-web@donaldson.com](mailto:ndl-ultrafilter-web@donaldson.com)

**Korea** 82-2-517-3333  
[cap-kr@donaldson.com](mailto:cap-kr@donaldson.com)

**Latin America** 52-449-300-2442  
[industrialair@donaldson.com](mailto:industrialair@donaldson.com)

**North America** 800-543-3634  
[processfilters@donaldson.com](mailto:processfilters@donaldson.com)

**South Africa** 27-11-997-6000  
[samarketing@donaldson.com](mailto:samarketing@donaldson.com)

**Southeast Asia** 65-6311-7373  
[sea.salesenquiry@donaldson.com](mailto:sea.salesenquiry@donaldson.com)

**F117000 ENG (11/19) P-EG Gas/Steam Filter Housings**

© 2007 Donaldson Co., Inc. All Rights Reserved. Donaldson and the color blue are marks of Donaldson Company, Inc. All other marks belong to their respective owners. {Contains Donaldson proprietary technology.}