

Notice: This drawing contains proprietary information and shall not be used or reproduced or its contents disclosed in whole or in part, without the prior written consent of the Mann Teknik AB

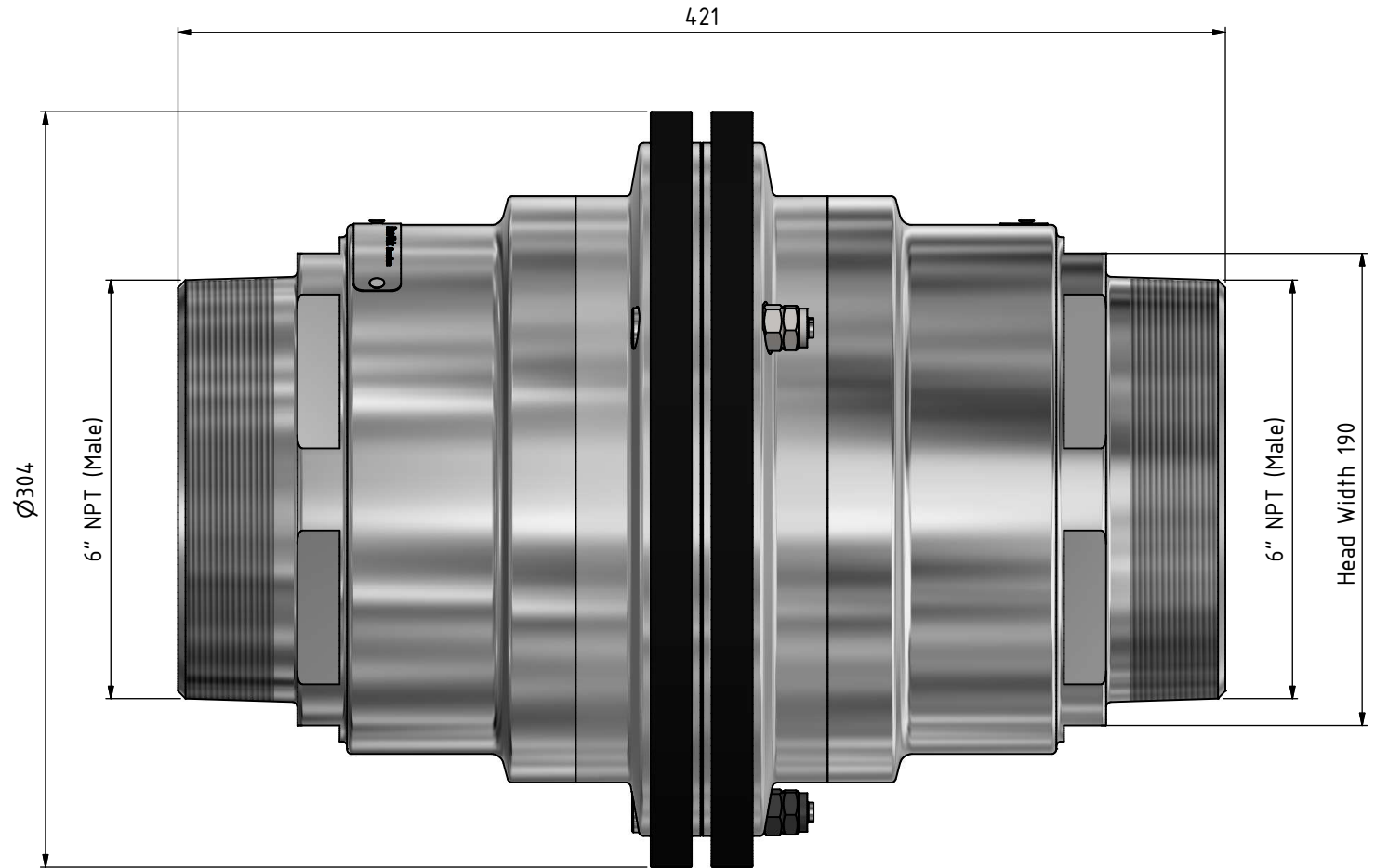

NO.	Revision comprises	Date	Sign.	Appr by
-----	--------------------	------	-------	---------

Detail No:	Material	Ämne/Blank	Ytbeh./Treatment	Vikt/Weight
<b>MannTek</b>	Designed/drawn by A. Sjöberg	Scale: 1 : 2	Dimension with no tolerances acc to Machined SS-ISO 2768-1 medium Weld Forge SS-ISO 2768-1 coarse Surface roughness SS-ISO 1302 Form & position tol SS-ISO 2768-2-K	
	Checked G. Nilsson	Date 2018-05-14		
	Approved T. Mann			
<b>Marine Break Away 6"</b> <b>Thread 6" NPT male</b>			Data nr./Comp No. N6116M4401	Blad/Sheet 1 / 1
			Drawing No. <b>N6116M4401-1</b>	Rev. -