

# PC150 SHOP IN A BOX

## Quick Start Guide

Use your smartphone to scan the Continental QR Code to get full access to the operators manuals and training videos.



### SAFETY PRECAUTIONS



- Read instructions and identify all component parts before using the crimper and saw.
- Familiarize yourself with the safety and operating procedures for the crimper and saw before use.
- Use all safety precautions listed.
- Consult the Continental CrimpIQ™ Tablet for Crimp Specifications for correct crimper settings and crimp measurements.
- Always wear eye protection.

## Initial Setup



### Step # 1

Step #1. Position your new PC150 SHOP IN A BOX near to the appropriate electrical outlet. Check the voltage tag attached to the power strip supply cord #1, PC150-2 crimper's power cord #2 and HS-501 hose saw's power cord #4.

**Note:** Check electrical circuit to be certain that it matches the crimper and saw requirements shown on the voltage tag attached to the power cord.

Locate the power strip supply cord #1 and plug it directly into a 110V outlet. **Do not use an extension cord.** Plug in the CrimplQ™ Controller's power cord (3), and the light's power cord (5) into the power strip supply cord as shown in the picture.

**Caution:** Do not run the power strip, crimper, and saw on an extension cord, as low voltage can damage the motors and/or electrical components.

## Setting Up Accessories



### Step # 2

Step #2. Familiarize yourself with the safety and operating procedures for the crimper and saw before use. Use all safety precautions listed on the quick start guide.

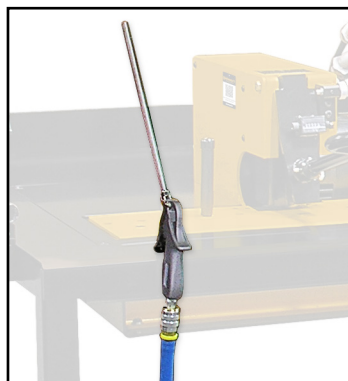

### Step # 3a

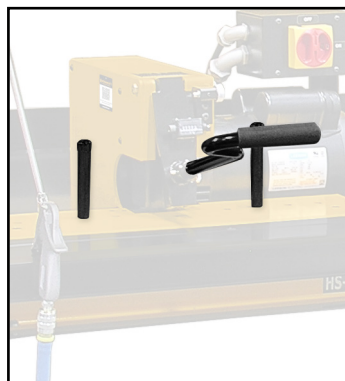

### Step # 3b



### Step # 3c

Step #3. Locate the tooling box, it contains the accessories needed to finish setting up your Shop-in-a-box.

- Connect air nozzle and Continental air hose to shop air supply.
- Install hose saw handle and alignment pins as shown.
- Note optional vacuum adapter is included if you want to connect see instructions in saw operating procedure.

## Setting Up Accessories



Step # 3d



Step # 3e



Step # 3f

- d. Place the inserting block assembly on the table as desired. Please note that this can go on the edge of table if needed.
- e. Removing tooling and lubrication and place on the rubber mat on table. Organize in a way you feel most efficient.
- f. Locate the tablet box, it contains the CrimpIQ™ tablet. This has the most recent Continental crimp specs readily available. This can be mounted to either signpost as shown.

## 36" Hose Reel Rack Instructions

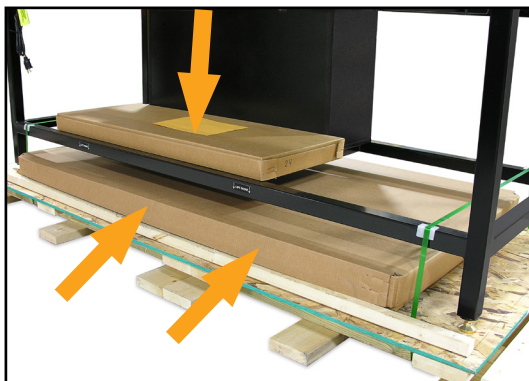

Step #4

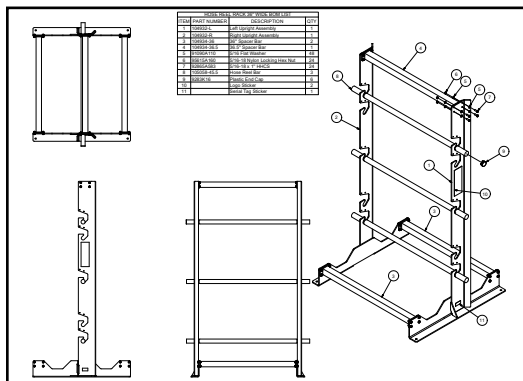

Step #5



Step #6

Step #4. Locate the hose reel box.

Step #5. Locate the instructions on how to assemble your stand alone hose reel rack assembly.

**Note:** Hardware included.

Step #6. Hose reel rack is shown fully assembled.

## Scanning Continental QR Code



Step #7



Step #8



Step #9

Step #7. Use your smartphone to scan the Continental QR Code to get full access to the operational manuals and training videos.

**Note:** If you don't have a QR code reader app installed in your smartphone, download it from your smartphone app store.

Step #8. Read the crimper quick start guide before operation. Scanning the QR code will allow access to the full operational manual.

Step #9. Read the hose saw quick start guide before operation. Scanning the QR code will allow access to the full operational manual.

## PC150 SHOP IN A BOX Identification Components

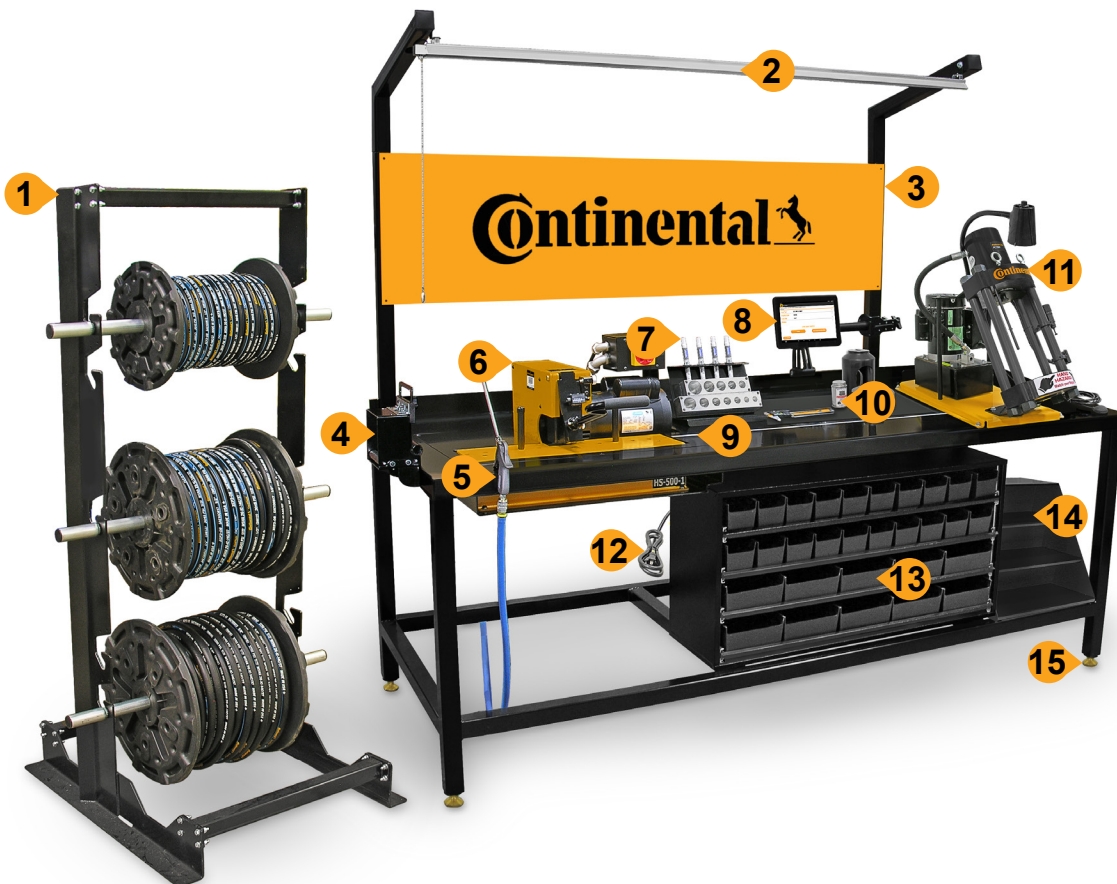

1. 36" Hose Reel Rack (Hose spools not included)
2. 6' LED Light Kit
3. 6' Continental Sign
4. Hose Helper
5. 10' Continental Air Hose with Nozzle
6. HS-501 Hose Saw (Handle, Vacuum Port, and Alignment Pins)
7. Insertion Block Assembly (B2 and SG blocks, (5) Paint Markers)
8. CrimpIQ™ Tablet and Mounting Arm
9. Tape Measure
10. PC150-2 Tooling Box and Tooling Mat
11. PC150-2 Crimper (Dies, Shelf, and Tooling Box)
12. 5' 110V Power Strip
13. 4 Drawer Cabinet with Small and Large Bins
14. PC150 Die Shelf
15. Adjustable Feet