

MATERIAL DESCRIPTION			
MODEL	KEY	QTY	HORIZONTAL DW UL 142 SKID TANK
Outer Diameter			5'-5"
Outer Length			6'-0"
Capacity			1000 US Gallons Nominal
Inner Gauge			Per UL 142 - 10 Gauge
Outer Gauge			Per UL 142 - 10 Gauge
Code			UL 142
Supports	A	2	Skids Full Length - 7 Gauge
Fill Opening	B	1	2" 150# Full Coupling W/Repad
Pump Opening	C	1	2" 150# Full Coupling W/Repad
Gauge Opening	D	1	2" 150# Full Coupling W/Repad
Op Vent Opening	E	1	2" 150# Full Coupling W/Repad
E-Vent Opening	F	1	6" Sch40 Nipple (Inner E-Vent) W/Repad
E-Vent Opening	G	1	6" Sch40 Nipple (Outer E-Vent)
Leak Monitor	H	1	2" Monitor Pipe (MNPT)
Lift Lug	J	2	Small Lift Lug
Inner Drain	K	1	1" 150# Full Coupling W/Repad
Remote Gauge	M	1	2" 150# Full Coupling W/Repad
UL Labeling	L	Set	Labeled Per Section 48 UL142 Code

TANK SHALL BE BUILT & LABELED PER UL 142 STANDARD FOR STEEL ABOVEGROUND TANKS FOR FLAMMABLE AND COMBUSTIBLE LIQUIDS  
UL FILE # MH5668

Surface Prep: Brush Blast  
Paint: Polane White  
Testing: Per UL 142  
Operating Pressure: Atmospheric  
Estimated Dry Weight: 1050lbs

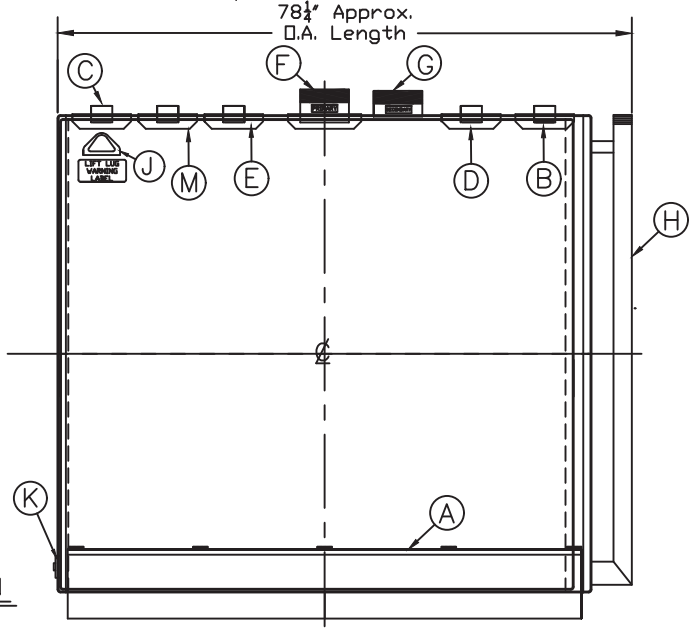

ELEVATION

SCALE