



EUROPEAN USERS

400V 50Hz SUPPLY DETAILS ARE INCLUDED WITH ELECTRICAL CONTROL BOX. DISREGARD SUPPLY WIRING DETAILS IN THIS MANUAL

IMPORTANT SAFETY INSTRUCTIONS SAVE THESE INSTRUCTIONS

PLEASE READ THE ENTIRE CONTENTS OF THIS MANUAL PRIOR TO INSTALLATION AND OPERATION. BY PROCEEDING WITH LIFT INSTALLATION AND OPERATION YOU AGREE THAT YOU FULLY UNDERSTAND AND COMPREHEND THE FULL CONTENTS OF THIS MANUAL. FORWARD THIS MANUAL TO ALL OPERATORS. FAILURE TO OPERATE THIS EQUIPMENT AS DIRECTED MAY CAUSE INJURY OR DEATH.

Revision B3 – February 2024
Part Number 5900001

INSTALLATION AND OPERATION MANUAL

FOUR-POST OPEN FRONT ALIGNMENT LIFTS COMMERCIAL GRADE 14,000 LBS. CAPACITY

Models:

- HDSO-14P
- HDSO-14AX

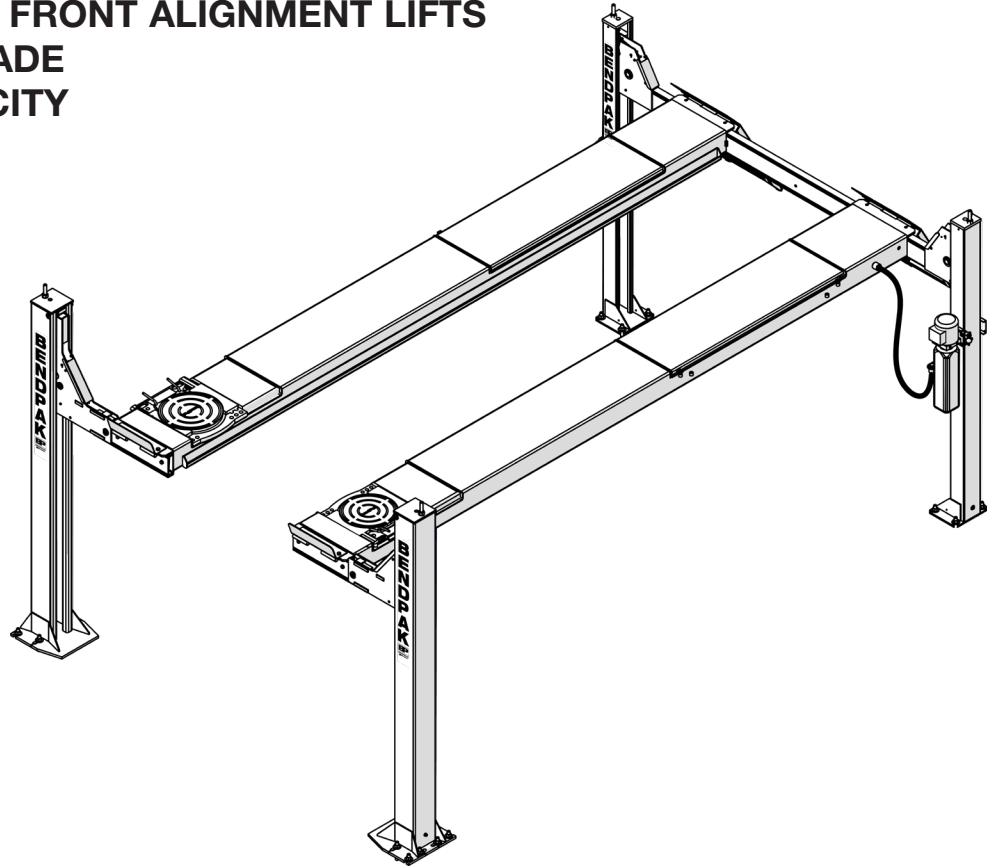

IMPORTANT SAFETY INFORMATION! SAVE THESE INSTRUCTIONS!

Do not attempt to install this Lift if you have never been trained on basic Automotive Lift installation procedures. Never attempt to Lift components without proper Lifting tools such as forklift or cranes. Stay clear of any moving parts that may fall and cause injury. These instructions must be followed to ensure proper installation and operation of your Lift. Failure to comply with these instructions can result in serious bodily harm and void product warranty.



John M. Ellsworth Co., Inc.

A John M. Ellsworth Company

P.O. Box 240072
8700 West Bradley Road
Milwaukee, WI 53224

800-333-3331 **PHONE**

info@jmesales.com **E-MAIL**
www.JMEsales.com **WEB**

14,000 POUND CAPACITY, COMMERCIAL GRADE FOUR POST OPEN FRONT ALIGNMENT AUTO / TRUCK Lift

This instruction manual has been prepared especially for you. Your new Lift is the product of over 40 years of continuous research, testing and development; it is the most technically advanced Lift on the market today.

READ THIS ENTIRE MANUAL BEFORE INSTALLATION & OPERATION BEGINS.

RECORD THE LIFT AND POWER UNIT INFORMATION WHICH IS LOCATED ON THE SERIAL NUMBER DATA PLATES ON THE LIFT AND ON THE POWER UNIT.

Power Unit Model # _____
Power Unit Date Of Mfg. _____
Power Unit Serial # _____

Maximum Operating
Hydraulic Pressure 2,950 PSI

**This information is required when
calling for parts or warranty issues.**

PRODUCT WARRANTY

Our comprehensive product warranty means more than a commitment to you; it's also a commitment to the value of your new BendPak Lift. For full warranty details and to register your new Lift contact your nearest BendPak dealer

NOTE:

Every effort has been taken to ensure complete and accurate instructions have been included in this manual, however, possible product updates, revisions and or changes may have occurred since this printing. BendPak Ranger reserves the right to change specifications without incurring any obligation for equipment previously or subsequently sold. Not responsible for typographical errors.

California Proposition 65. This product can expose you to chemicals including styrene and vinyl chloride which are on the list of over 900 chemicals identified by the State of California to cause cancer, birth defects or reproductive harm. Always use this product in accordance with BendPak's instructions. For more information, visit www.p65warnings.ca.gov.

IMPORTANT NOTICE

Do not attempt to install this Lift if you have never been trained on basic Automotive Lift installation procedures. Never attempt to Lift components without proper Lifting tools such as forkLift or cranes. Stay clear of any moving parts that may fall and cause injury. These instructions must be followed to ensure proper installation and operation of your Lift. Failure to comply with these instructions can result in serious bodily harm and void product warranty. Manufacturer will assume no liability for loss or damage of any kind, expressed or implied resulting from improper installation or use of this product.

PLEASE READ ENTIRE MANUAL PRIOR TO INSTALLATION.

DEFINITIONS OF HAZARD LEVELS

Identify the hazard levels used in this manual with the following definitions and signal words:



Watch for this symbol: It means immediate hazards which will result in severe personal injury or death.



Watch for this symbol: It means hazards or unsafe practices which could result in severe personal injury or death.



Watch for this symbol: It means hazards or unsafe practices which may result in minor personal injury, product or property damage.

OWNER'S RESPONSIBILITY

It is the owner's responsibility to read and follow these instructions to maintain the Lift and user safety:

- ◆ Follow all installation and operation instructions.
- ◆ Make sure installation conforms to all applicable Local, State, and Federal Codes, Rules, and Regulations; such as State and Federal OSHA Regulations and Electrical Codes.
- ◆ Carefully check the Lift for correct initial function.
- ◆ Read and follow the safety instructions. Keep them readily available for machine operators.
- ◆ Make certain all operators are properly trained, know how to safely and correctly operate the unit, and are properly supervised.
- ◆ Allow unit operation only with all parts in place and operating safely.
- ◆ Carefully inspect the unit on a regular basis and perform all maintenance as required.
- ◆ Service and maintain the unit only with authorized or approved replacement parts.
- ◆ Keep all instructions permanently with the unit and all decals on the unit clean and visible.

Always make a visual inspection of the Lift before using it. Do not use the Lift if you find any missing or damaged parts. Instead, take it out of service, then contact an authorized repair facility, your distributor, or BendPak at (800) 253-2363, select option 7 then 4, or email support@bendpak.com.

BendPak makes no promises, guarantees or assurances that our products meet any state, county, federal or international mandated permit, license, code, standard, certification, or any other mandate other than what is listed or shown on BendPak website(s), or any BendPak or Ranger online or published catalog. Not all BendPak Lift models meet the standards as prescribed by ANSI/ALI ALCTV-(current edition) or ANSI/UL 201. Consult www.autolift.org for a complete list of Lift models that meet ANSI/ALI ALCTV-(current edition) or ANSI/UL 201, or contact BendPak via contact@bendpak.com. Buyer assumes full responsibility for any state, county, federal or international mandated permit, license, code, standard, certification, or any other mandate required related to the installation and/or operation of any BendPak product. BendPak will not be responsible for any charges, fines, liens, or other levies imposed on the Buyer related to any special or regional structural, seismic or any other building code and/or codes such as the Uniform Building Code (UBC), International Building Code (IBC), or any other state, county, federal or international mandated permit, license, code, standard, certification, or other mandate, law, rule, regulation or directive by any other agency, government, administrations, or corporations whether state, county, federal, or international mandated.



ONLY USE THE LIFT IF IT CAN BE USED SAFELY!

BEFORE YOU BEGIN

Receiving:

The shipment should be thoroughly inspected as soon as it is received. The signed bill of lading is acknowledgement by the carrier of receipt in good condition of shipment covered by your invoice. If any of the goods called for on this bill of lading are shorted or damaged, do not accept them until the carrier makes a notation on the freight bill of the shorted or damaged goods. Do this for your own protection.

NOTIFY THE CARRIER AT ONCE if any hidden loss or damage is discovered after receipt and request the carrier to make an inspection. If the carrier will not do so, prepare a signed statement to the effect that you have notified the carrier (on a specific date) and that the carrier has failed to comply with your request.

IT IS DIFFICULT TO COLLECT FOR LOSS OR DAMAGE AFTER YOU HAVE GIVEN THE CARRIER A CLEAR RECEIPT. File your claim with the carrier promptly. Support your claim with copies of the bill of lading, freight bill, invoice, and photographs, if available. Our willingness to assist in helping you process your claim does not make BendPak responsible for collection of claims or replacement of lost or damaged materials.

Liability Information

BendPak assumes no liability for damages resulting from:

- Use of the equipment for purposes other than those described in this manual.
- Modifications to the equipment without prior, written permission from BendPak.
- Injury or death caused by modifying, disabling, overriding, or removing safety features.
- Damage to the equipment from external influences.
- Incorrect operation of the equipment.

TABLE OF CONTENTS

Warranty / Serial Number Information	2
Definitions of Hazard Levels	3
Owner's Responsibility	3
Before You Begin.	4
Installers / Operators Agreement / Protective Equipment	6
Safety / Warning Instructions	7
Step 1 / Selecting Site / Tools Required	9
Step 2 / Floor Requirements / Concrete Specifications	9
Assembly View / Description of Parts	10
Floor Plan / Specifications	11
Clearances	12
Power Unit Location.	13
Step 3 / Column and Cross Tube Installation.	14-15
Step 4 / Anchoring The Columns	16
Step 5 / Raising the Cross Tubes	17
Step 6 / Powerside Runway Installation	18
Step 7 / Offside Runway Installation	18
Step 8 / Cable Sheave Installation	19
Step 9 / Cable Installation	20
Step 10 / Power Unit Installation	21
Step 11 / Routing Hydraulic Hoses	22-23
Step 12 / Routing Air Lines	24
Step 13 / Power Unit Hook Up / Hydraulic Warnings	26-30
Step 14 / Inspecting Slack Safety Springs	30
Step 15 / Lift Start Up / Final Adjustments	30
Step 16 / Attaching Approach Ramps / Tire stops.. . . .	31
Step 17 / Leveling/Synchronizing	32
Step 18 / Bleeding	33
Step 19 / Anti-Slip Tape	33-34
Optional Equipment Installation.	36
Step 19 / Operation Instructions	38
Step 20 / Lift Operation Safety / Lubrication	39-41
Wire Rope Inspection and Maintenance	42
Safe Lift Operation	43-44
Troubleshooting Guide	45-48
Labels	48
Parts Drawings.	52-64
Maintenance Logs.	65

**INSTALLER / OPERATOR
PLEASE READ AND FULLY
UNDERSTAND.
BY PROCEEDING YOU AGREE TO
THE FOLLOWING.**

- ◆ I have visually inspected the site where the Lift is to be installed and verified the concrete to be in good condition and free of cracks or other defects. I understand that installing a Lift on cracked or defective concrete could cause Lift failure resulting in personal injury or death.
- ◆ I understand that a level floor is required for proper installation and level Lifting.
- ◆ I understand that I am responsible if my floor is of questionable slope and that I will be responsible for all charges related to pouring a new level concrete slab if required and any charges.
- ◆ I understand that BendPak Lifts are supplied with concrete fasteners meeting the criteria of the American National Standard "Automotive Lifts - Safety Requirements for Construction, Testing, and Validation" ANSI/ALI ALCTV-(Current Edition), and that I will be responsible for all charges related to any special regional structural and/or seismic anchoring requirements specified by any other agencies and/or codes such as the Uniform Building Code (UBC) and/or International Building Code (IBC).
- ◆ I assume full responsibility for the concrete floor and condition thereof, now or later, where the above equipment model(s) are to be installed. Failure to follow danger, warning, and caution instructions may lead to serious personal injury or death to operator or bystander or damage to property.
- ◆ I understand that Bendpak Lifts are designed to be installed in indoor locations only. Failure to follow installation instructions may lead to serious personal injury or death to operator or bystander or damage to property or Lift.
- ◆ **Outdoor installations are strictly prohibited.**



Failure to follow danger, warning, and caution instructions may lead to serious personal injury or death to operator or bystander or damage to property.



Please read entire manual prior to installation. Do not operate this machine until you read and understand all the dangers, warnings and cautions in this manual. For additional copies or further information, contact:

BendPak Inc. / Ranger Products

1645 Lemonwood Dr.

Santa Paula, CA. 93060

1-805-933-9970

www.bendpak.com

**INSTALLER / OPERATOR
PROTECTIVE EQUIPMENT**

Personal protective equipment helps makes installation and operation safer, however, it does not take the place of safe operating practices. Always wear durable work clothing during any installation and/or service activity. Shop aprons or shop coats may also be worn, however loose fitting clothing should be avoided. Tight fitting leather gloves are recommended to protect technician hands when handling parts. Sturdy leather work shoes with steel toes and oil resistant soles should be used by all service personnel to help prevent injury during typical installation and operation activities.

Eye protection is essential during installation and operation activities. Safety glasses with side shields, goggles, or face shields are acceptable. Back belts provide support during Lifting activities and are also helpful in providing worker protection. Consideration should also be given to the use of hearing protection if service activity is performed in an enclosed area, or if noise levels are high.



THIS SYMBOL POINTS OUT IMPORTANT SAFETY INSTRUCTIONS WHICH IF NOT FOLLOWED COULD ENDANGER THE PERSONAL SAFETY AND/OR PROPERTY OR YOURSELF AND OTHERS AND CAN CAUSE PERSONAL INJURY OR DEATH. READ AND FOLLOW ALL INSTRUCTIONS IN THIS MANUAL BEFORE ATTEMPTING TO OPERATE THIS MACHINE.

INTRODUCTION

1. Carefully remove the crating and packing materials. **CAUTION!** Be careful when cutting steel banding material as items may become loose and fall causing personal harm or injury.

2. Check the voltage, phase and amperage requirements for the motor shown on the motor plate. Wiring should be performed by a certified electrician only.

IMPORTANT SAFETY INSTRUCTIONS

Read these safety instructions entirely!

IMPORTANT NOTICE

Do not attempt to install this Lift if you have never been trained on basic automotive Lift installation procedures.

Never attempt to Lift components without proper Lifting tools such as ForkLift or Cranes.

Stay clear of any moving parts that can fall and cause injury.

1. **READ AND UNDERSTAND** all safety warning procedures and instructions before operating Lift.

2. **KEEP HANDS AND FEET CLEAR.** Remove hands and feet from any moving parts. Keep feet clear of Lift when lowering. Avoid pinch points.

3. **KEEP WORK AREA CLEAN.** Cluttered work areas invite injuries.

4. Consider work area environment. Do not expose equipment to rain. **DO NOT** use in damp or wet locations. Keep area well lighted.

5. **ONLY TRAINED OPERATORS** should operate this Lift. All non-trained personnel should be kept away from work area. Never let non-trained personnel come in contact with, or operate the Lift.

6. **USE LIFT CORRECTLY.** Use Lift in the proper manner. Never use Lifting adapters other than what is approved by the manufacturer.

7. **DO NOT** override self-closing Lift controls.

8. **REMAIN CLEAR** of Lift when raising or lowering Vehicle.

9. **CLEAR AREA** if Vehicle is in danger of falling.

10. **ALWAYS ENSURE** that the safeties are engaged before any attempt is made to work on or near Vehicle.

11. **DRESS PROPERLY.** Non-skid steel-toe footwear is recommended when operating Lift.

12. **GUARD AGAINST ELECTRIC SHOCK.** This Lift must be grounded while in use to protect the operator from electric shock. Never connect the green power cord wire to a live terminal. This is for ground only.



13. **DANGER!** The power unit used on this Lift contains high voltage. Disconnect power at the receptacle before performing any electrical repairs. Secure plug so that it cannot be accidentally plugged in during service.



14. **WARNING! RISK OF EXPLOSION.** This equipment has internal arcing or sparking parts which should not be exposed to flammable vapors. This machine should not be located in a recessed area or below floor level.



15. **MAINTAIN WITH CARE.** Keep Lift clean for better and safer performance. Follow manual for proper lubrication and maintenance instructions. Keep control handles and/or buttons dry, clean and free from grease and oil.

16. **STAY ALERT.** Watch what you are doing. Use common sense. Be aware.

17. **CHECK FOR DAMAGED PARTS.** Check for alignment of moving parts, breakage of parts or any condition that may affect its operation. Do not use Lift if any component is broken or damaged.

18. **NEVER** remove safety related components from the Lift. Do not use Lift if safety related components are damaged or missing.

19. Keep hair, loose clothing, fingers, and all parts of body away from moving parts

20. Use only as described in this manual. Use only manufacturer's recommended attachments

21. **ALWAYS WEAR SAFETY GLASSES.** Everyday eyeglasses only have impact resistant lenses, they are not safety glasses

22. **SAVE THESE INSTRUCTIONS.**

23. Use only as described in this manual.
24. Only operate your Lift between temperatures of 41°F to 104°F (5°C to 40°C).
25. Make sure all operators read and understand this Installation and Operation Manual. Keep the manual near the Lift at all times. The Lift should only be operated by authorized personnel. Keep children and untrained personnel away from the Lift.
26. BendPak recommends referring to the ANSI/ALI ALIS Standard Safety Requirements for Installation and Service for more information about safely installing, using, and servicing your Lift.
27. The Lift should only be operated by authorized personnel. Keep children and untrained personnel away from the Lift.
28. Do not make any modifications to the Lift; this voids the warranty and increases the chances of injury or property damage. Use only factory-approved attachments.
29. Do not use the Lift while tired or under the influence of drugs, alcohol, or medication.
30. Do not touch hot parts; you could be burned. Always use care with the equipment.
31. Do not operate equipment with a damaged cord or if the equipment has been dropped or damaged – until a qualified service person has examined it.
32. Do not let a cord hang over the edge of a table, bench, or counter or come in contact with hot manifolds or moving fan blades. Loop the power cord around equipment when storing.
33. If an extension cord is necessary, a cord with a current rating equal to or greater than that of the equipment should be used. Cords rated for less current than the equipment may overheat. Care should be taken to arrange the cord so that it will not be tripped over or pulled out.
34. Always unplug equipment from electrical outlets when not in use. Never use the cord to pull the plug from the outlet. Grasp plug and pull to disconnect.
35. To reduce the risk of a fire, do not operate equipment in the vicinity of open containers of flammable liquids (like gasoline).
36. Adequate ventilation should be provided when working on operating internal combustion engines.
37. Keep hair, loose clothing, fingers, and all parts of the body away from moving parts.
38. To reduce the risk of electric shock, do not use the unit on wet surfaces or expose to rain.
39. Always wear safety glasses! Everyday glasses only have

impact resistant lenses, they are not safety glasses. Save these instructions!

Additional Safety Information

The following safety information applies to all BendPak HDSO-14P/AX Series models:

- The HD-14P/AX are Four-Post Lifts. Use them only for their intended purpose.
- You must wear OSHA-approved (publication 3151) personal protective equipment at all times when installing, using, maintaining, or repairing the Lift. Leather gloves, steel-toed work boots, eye protection, back belts, and hearing protection are mandatory.
- Never exceed the rated capacity of the Lift.
- When the Lift is in use, keep hands and all body parts well away from it.
- Keep loads balanced on the Lift. Clear the area immediately if a Vehicle is in danger of falling off the Lift.
- Modifications void the warranty and increase the chances of injury or property damage. Do not modify any safety-related features in any way.
- The Lift uses electrical energy; if your organization has Lockout/Tagout policies, make sure to implement them after connecting the Lift to a power source.
- When handling the Hydraulic components, always wear safety gloves! In rare cases, a needle-like stream of Hydraulic Fluid (even at low pressure) can penetrate fingers, hands, or arms. Such a puncture can feel like a bite, electric shock, or a prick. While it may seem like a minor issue, any amount of Hydraulic Fluid injected into the human body is a serious issue. Anyone suffering such a puncture wound should be immediately taken as an emergency to the hospital to determine the extent of the injury. Explain the circumstances of the injury to the attending physician, including what type of Hydraulic Fluid was involved. Do not assume a puncture wound that could have been caused by Hydraulic Fluid is a minor issue; it could be life-threatening.
- Make a visual inspection of the Lift before using it. Do not use the Lift if you find any missing or damaged parts. Instead, take it out of service, then contact an authorized repair facility, your distributor, or BendPak at (800) 253-2363, select option 7 then 4, or email support@bendpak.com.
- BendPak recommends making a thorough inspection of the Lift at least once a year. Replace any damaged or severely worn parts, decals, or warning labels.

TOOLS REQUIRED

- ◆ Rotary Hammer Drill or Similar
- ◆ 3/4" Masonry Bit
- ◆ Hammer
- ◆ 4-Foot Level
- ◆ Open-End Wrench Set: SAE/Metric
- ◆ Socket And Ratchet Set: SAE/Metric
- ◆ Hex-Key / Allen Wrench Set
- ◆ 14mm Socket/Hex-Key
- ◆ Large Crescent Wrench
- ◆ Large Pipe Wrench
- ◆ Crow Bar
- ◆ Chalk Line
- ◆ Medium Flat Screwdriver
- ◆ Tape Measure: 25 Foot Minimum
- ◆ Needle Nose Pliers

NOTE:

An air supply (50 PSI min. / 3 CFM min.) will be required for the safety-lock mechanisms.

IMPORTANT NOTICE

These instructions must be followed to ensure proper installation and operation of your Lift. Failure to comply with these instructions can result in serious bodily harm and void product warranty. Manufacturer will assume no liability for loss or damage of any kind, expressed or implied resulting from improper installation or use of this product.

PLEASE READ ENTIRE MANUAL PRIOR TO INSTALLATION

STEP 1

(Selecting Site)

Before installing your new Lift, check the following.

1. **Lift LOCATION:** Always use architects plans when available. Check layout dimension against floor plan requirements making sure that adequate space is available.
2. **OVERHEAD OBSTRUCTIONS:** The area where the Lift will be located should be free of overhead obstructions such as heaters, building supports, electrical lines, etc.
3. **DEFECTIVE FLOOR:** Visually inspect the site where the Lift is to be installed and check for cracked or defective concrete.



4. Lift is designed for **INDOOR INSTALLATION ONLY. OUTDOOR INSTALLTION IS PROHIBITED.** Always follow warnings illustrated on equipment labels.

STEP 2



(Floor Requirements)

This Lift must be installed on a solid level concrete floor.

A level floor is suggested for proper use and installation and level Lifting. If a floor is of questionable slope, consider a survey of the site and/or the possibility of pouring a new level concrete slab.



- ◆ DO NOT install or use this Lift on any asphalt surface or any surface other than concrete.
- ◆ DO NOT install or use this Lift on expansion seams or on cracked or defective concrete.
- ◆ DO NOT install or use this Lift on a second / elevated floor without first consulting a building architect.
- ◆ Refer to ANSI/ALI ALIS Standard (current version) *Safety Requirements for Installation and Service* for more information about safely installing your Lift.

CONCRETE SPECIFICATIONS

Lift MODEL	CONCRETE REQUIREMENTS
HDSO-14P	4.25" Min. Thickness / 3,000 PSI
HDSO-14AX	4.25" Min. Thickness / 3,000 PSI



All models **MUST** be installed on 3,000 PSI concrete only conforming to the minimum requirements shown above. New concrete must be adequately cured by at least 28 days minimum.

IMPORTANT NOTE:

BendPak Lifts are supplied with installation instructions and concrete fasteners meeting the criteria as prescribed by the American National Standard "Automotive Lifts - Safety Requirements for Construction, Testing, and Validation" ANSI/ALI ALCTV. Lift buyers are responsible for any special regional structural and/or seismic anchoring requirements specified by any other agencies and/or codes such as the Uniform Building Code (UBC) and/or International Building Code (IBC).

! DANGER

When removing the Lift from shipping angles pay close attention as the runways can slide and can cause injury. Prior to removing the bolts verify the runways are held securely by a forklift or some other heavy lifting device.

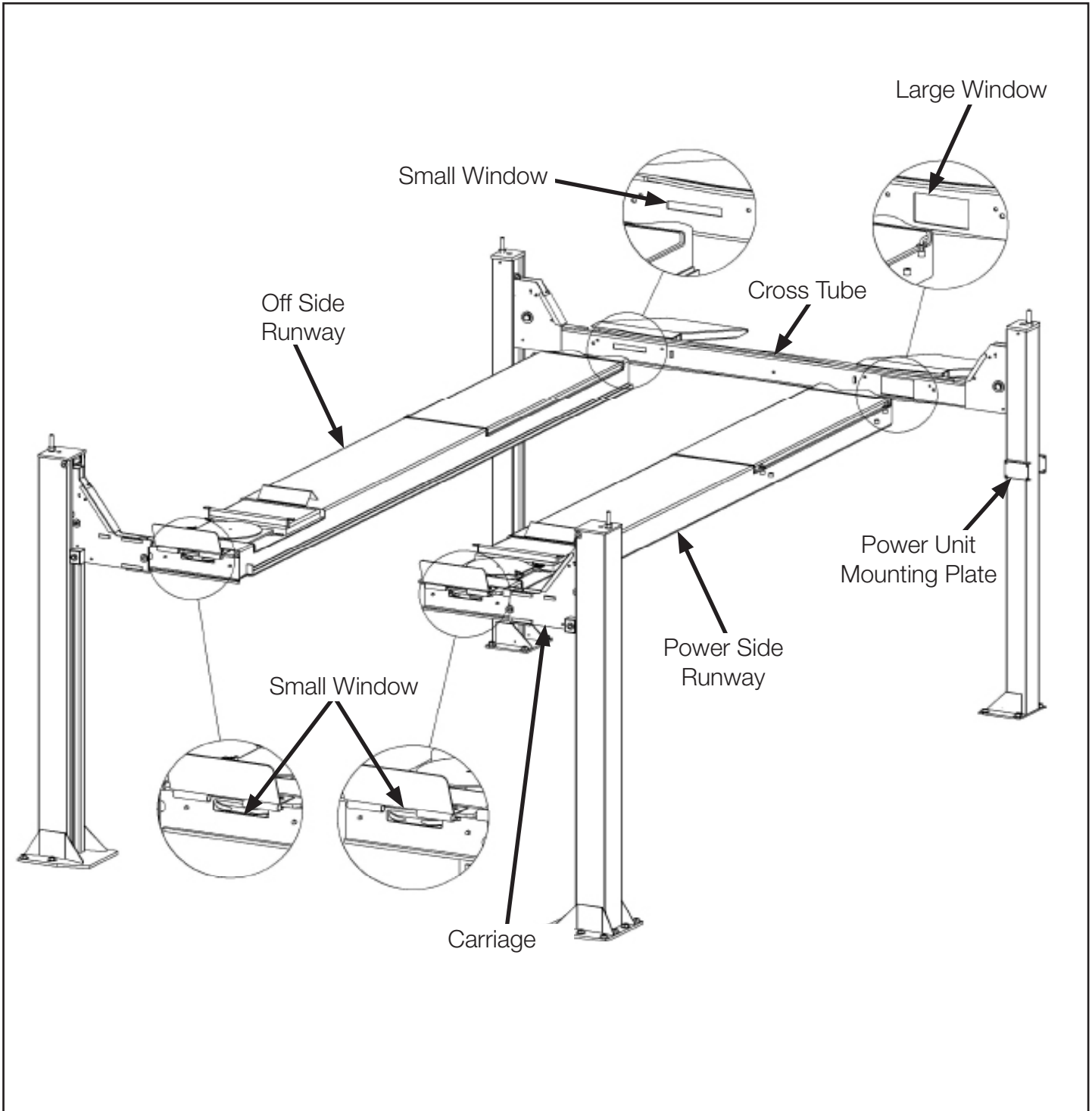

IMPORTANT NOTE:

It is important to locate the POWER-SIDE runway (with cylinder) on the SAME SIDE as the power unit. Rolling Jack / Utility rails on the side of each runway MUST be installed to the inside, facing each other.

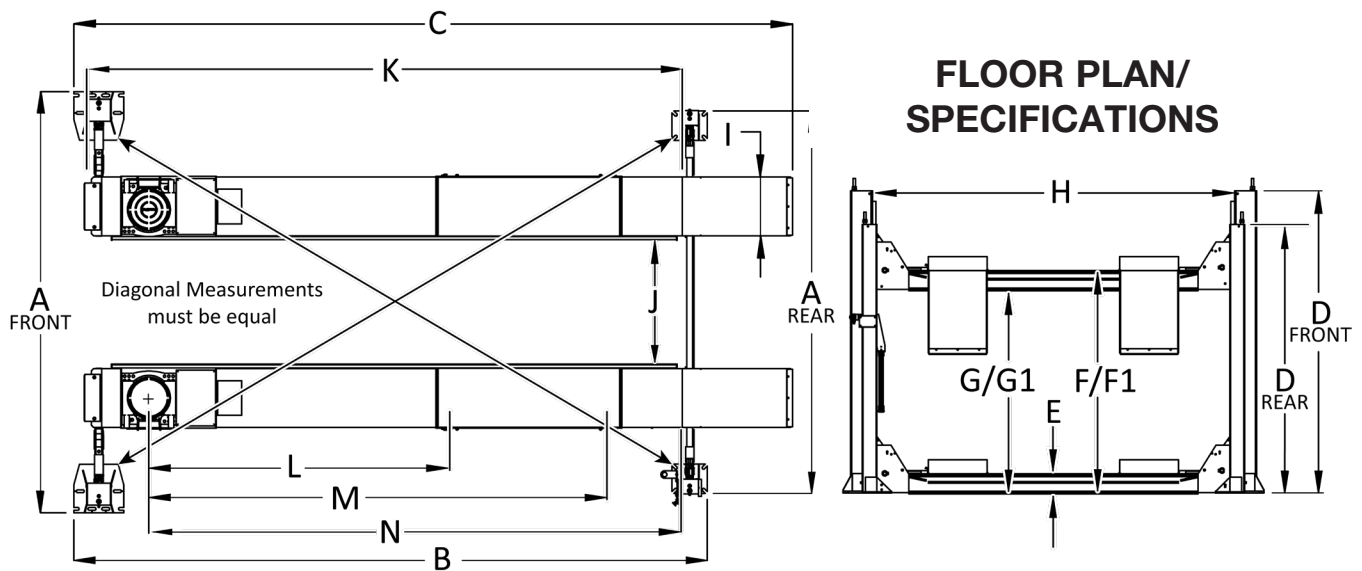

Model	HDSO-14P	HDSO-14AX
Lifting Capacity	14,000 lbs. (6350 kg)	14,000 lbs. (6350 kg)
A - Overall Width / Front	143.25 in. (3638 mm)	143.25 in. (3638 mm)
A - Overall Width / Rear	130 in. (3,304 mm)	130 in. (3,304 mm)
B - Outside Length	215.5 in. (5,472 mm)	215.5 in. (5,472 mm)
C - Overall Length	244.5 in. (6,209 mm)	244.5 in. (6,209 mm)
D - Height of Columns / Front (*)	103.25 in. (2,623 mm) max.	103.25 in. (2,623 mm) max.
D - Height of Columns / Rear(*)	92 in. (2,338 mm) max.	92 in. (2,338 mm) max.
E - Min. Runway Height	7.75 in. (196 mm)	7.75 in. (196 mm)
F - Max Lifting Height	77.5 in. (1,970 mm)	77.5 in. (1,970 mm)
F1 - Max. Lifting Height (Top Lock)	76.25 in. (1,937 mm)	76.25 in. (1,937 mm)
G - Max. Rise	70 in. (1,778 mm)	70 in. (1,778 mm)
G1 - Max. Rise (Top Lock)	68.75 in. (1,747 mm)	68.75 (1747 mm)
H - Width Between Columns / Front	123 in. (3,127 mm)	123 in. (3,127 mm)
H - Width Between Columns / Rear	120 in. (3,050 mm)	120 in. (3,050 mm)
I - Runway Width	20 in. (508 mm)	20.5 in. (520 mm)
J - Width Between Runways(**)	42 in. (1,070 mm)	42 in. (1,070 mm)
K - Length of Runways	197.5 in. (5,016 mm)	197.5 in. (5,016 mm)
L - Min. 4- Wheel Alignment (***)	N/A	89 in. (2,261 mm)
M - Max 4 Wheel Alignment (***)	N/A	156 in. (3,962 mm)
N - Max 2 Wheel Alignment (***)	N/A	182 in. (4,623 mm)
Min. Wheelbase @ Rated Capacity	140 in. (3,556 mm)	140 in. (3,556 mm)
Min. Wheelbase 75% Rated Capacity	120 in. (3,048 mm)	120 in. (3,048 mm)
Min. Wheelbase 50% Rated Capacity	100 in. (2,540 mm)	100 in. (2,540 mm)
Min. Wheelbase 25% Rated Capacity	80 in. (2,032 mm)	80 in. (2,032 mm)
Locking Positions	15	15
Lock Spacing	Every 4 in. (101 mm)	Every 4 in. (102 mm)
Lifting Time	60 Seconds	60 Seconds
Standard Motor Power Requirements	208-240 VAC 50/60Hz. 1 Ph., 3HP, Approx. 10 Amps	
Air Pressure Required	50 psi min. 125 psi max. at 3 cfm min.	
Sound pressure at Operator Position	< 70 dB(A)	
* Safety Ladder Adjustment bolt may add up to 3.75 in. / 95 mm to overall column height.		
** This dimension may be limited with the addition of rolling jacks.		
*** For CE compliant countries see errata sheet included with control panel.		
All design, material and specifications are subject to change without notice.		

CLEARANCES

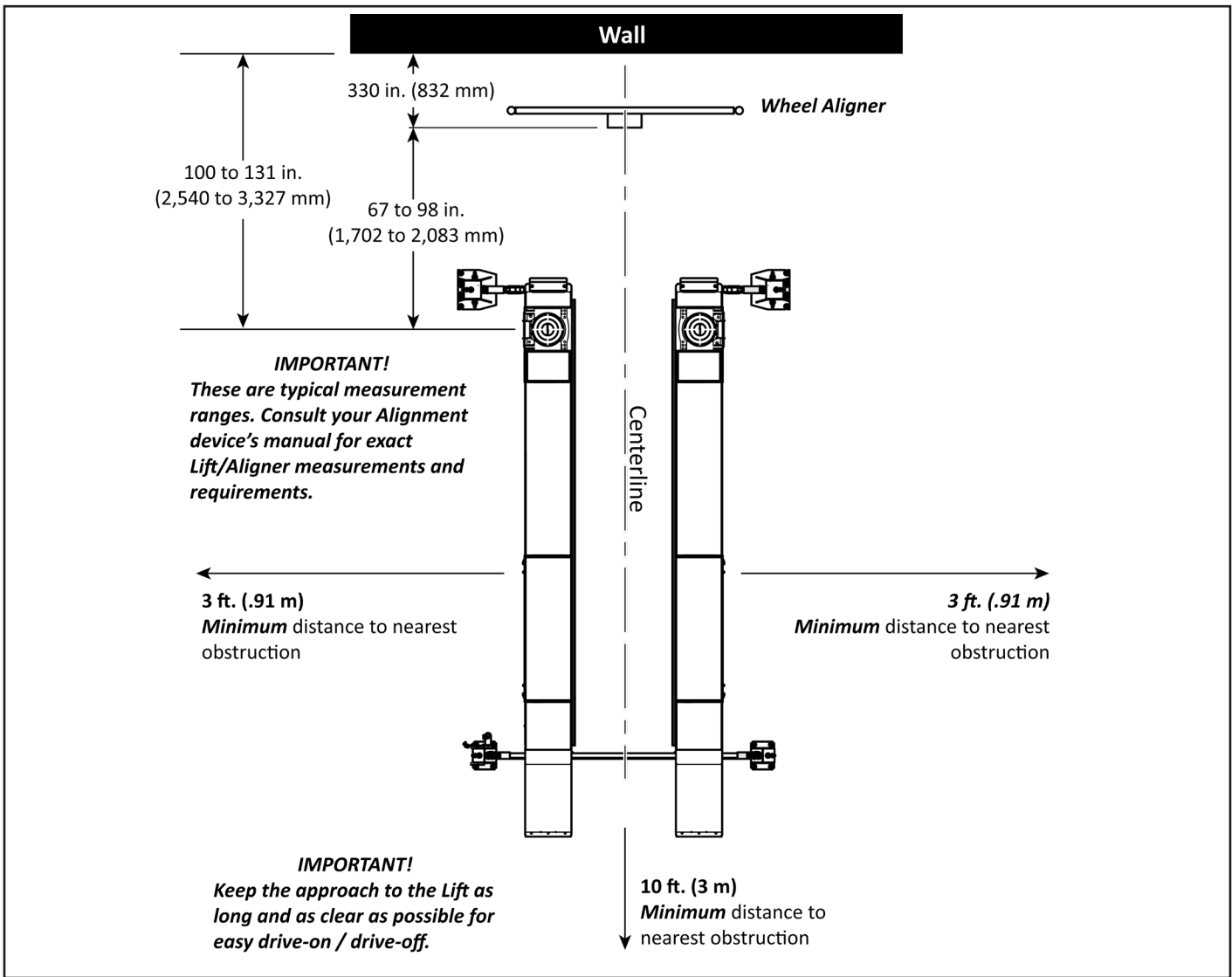

1. Lift Location: Use architects plan and an Engineers automatic level (transit) when available to locate the Lift. The above shows clearances of a typical bay layout. Lift floor area should be level.

2. Ceiling or overhead clearance must be 80" plus height of tallest Vehicle.

3. Estimating Column Shim requirements:
In the following section, the terms "highest" and "lowest" refer to floor elevation.

a. Mark locations where the Lift columns will be positioned in bay.

b. Place target on floor at column positions (NOT on column base plates) and record readings.

c. Find the highest of the four locations. Find the difference between the readings at each of the remaining three columns and the highest reading.

d. The difference is the estimated amount of shim thickness needed at each column.

Note: Maximum shim thickness is 1/2" per column using shims and anchors provided with Lift.

If no transit is available, floor slope can be determined by using a chalk line and level.

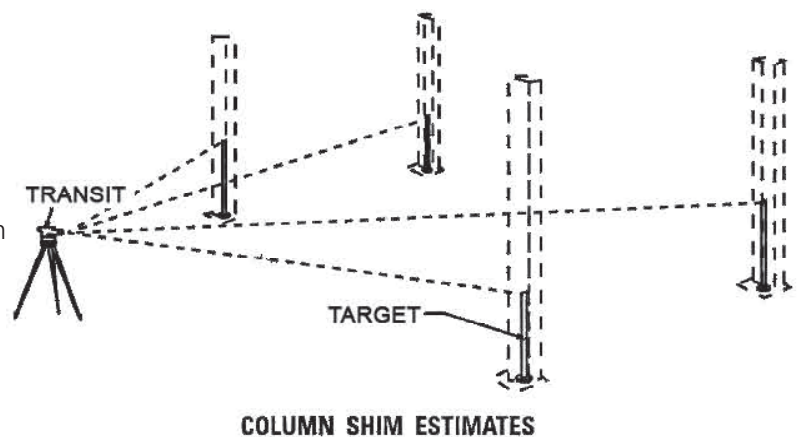

POWER UNIT LOCATION

The power unit will be located at "X" location shown below. It is important to locate the POWER SIDE runway (with cylinder) on the SAME SIDE as the power unit location.
Note the location of the bulkhead fitting holes in the POWER SIDE runway.
Utility rails on the side of each runway MUST be installed to the inside.

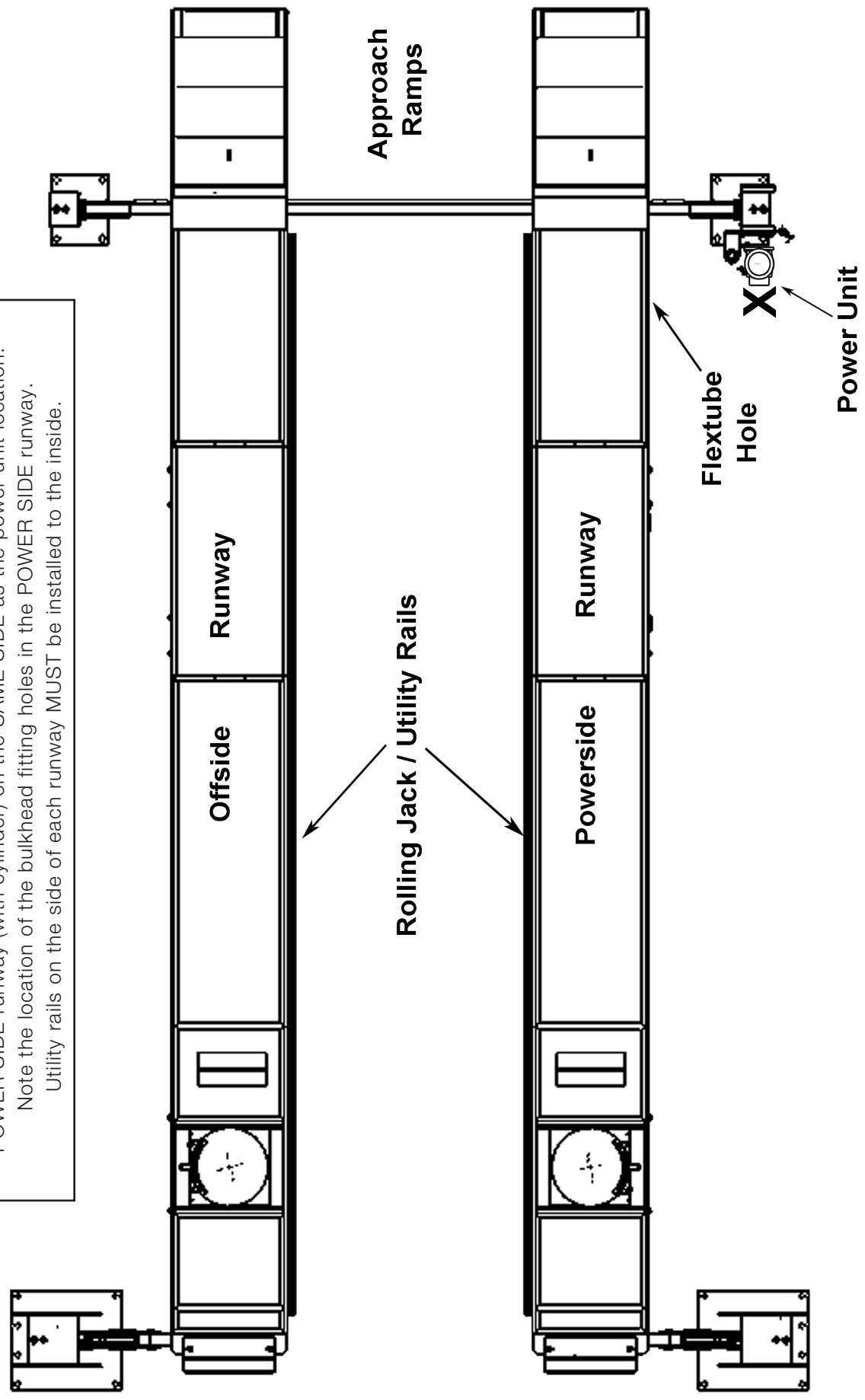

STEP 3

(Column & Cross Tube Installation)

1. Place a chalk line on the floor according to the floor plan layout. Pay attention to the Power Unit location. Locate and stand the Columns at their respective locations. **DO NOT BOLT** columns down at this time. Use caution to prevent the Columns from falling over. (See Fig. 3.1)

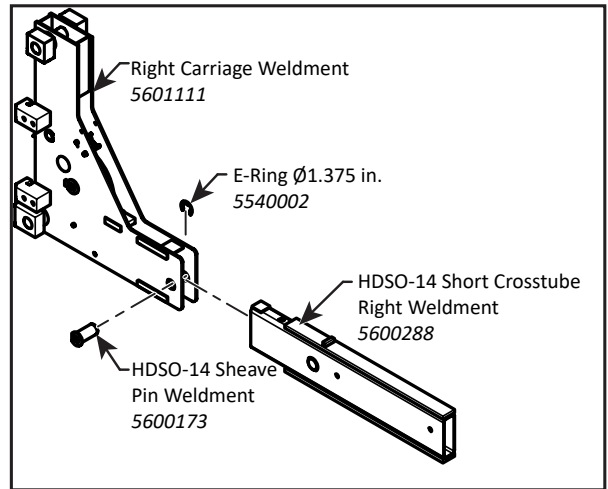
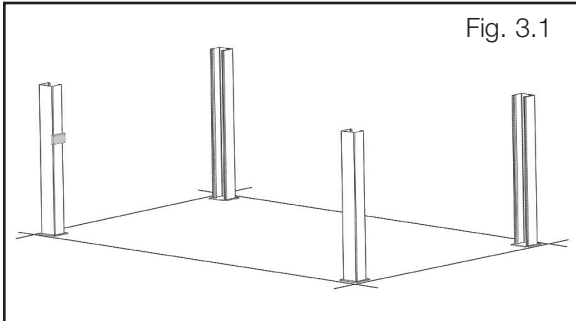

2. To estimate the shim requirements, place a target on floor at each Column position and record the readings. Find the highest of the four locations then find the difference between each of the remaining Columns. This difference is the estimated amount of shim thickness that will be required at each Column. (See Fig. 3.2)

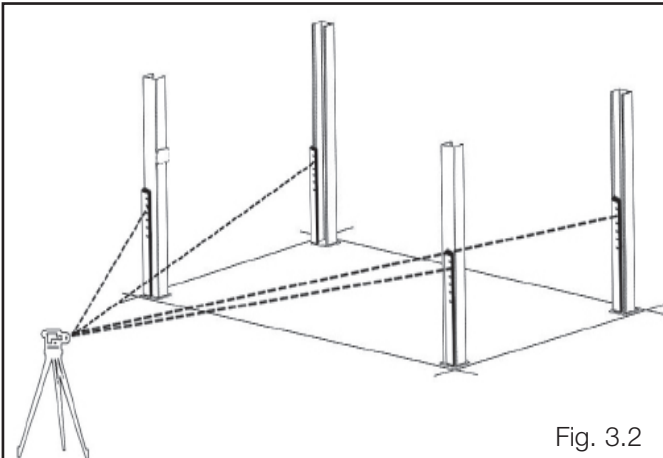

Note: The maximum shim thickness recommended by the factory is no more than 1/2" per Column using shims and anchors provided with the Lift. A maximum shim thickness of 2" is possible by ordering optional shim plates. Contact your authorized BendPak Distributor for ordering information.

3. Assemble the Left and Right Short Crosstube and Carriage Weldment as shown in the following figures.

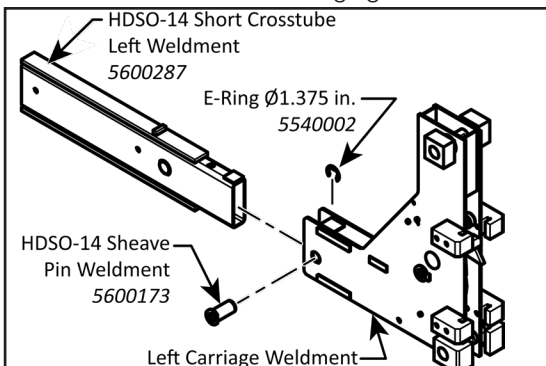

⚠ CAUTION

4. Using a forkLift or crane, raise the Cross tubes (making sure the Plastic Slide Blocks and Buttons are still in position) and slide down into the top of the Columns. NOTE: The Large Sheave Window should be positioned inward and adjacent the Power Unit Column. (See Figs. 3.3, 3.3a, 3.3b)

ENSURE THAT ALL SLIDE BLOCKS AND BUTTON SLIDES ARE IN POSITION ON ALL CROSSTUBES AS SHOWN BEFORE PROCEEDING.

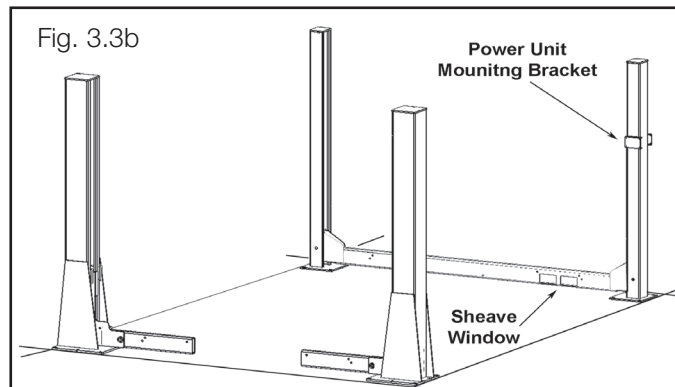
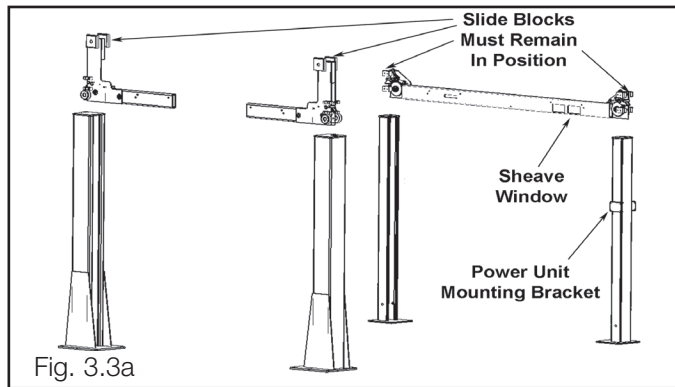
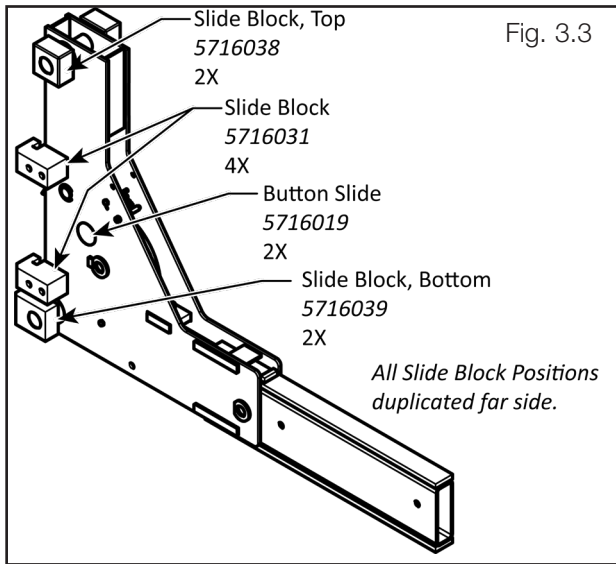

5. With the Columns standing and the cross tubes in position, install the Safety Ladders. Pass the ladders through the Column openings and drop down through the Slide Block guide slots on the Cross Tube until the Ladders come to rest on the Base Plates. **DO NOT BOLT** Columns down at this time. (See Fig. 3.4 - 3.7)

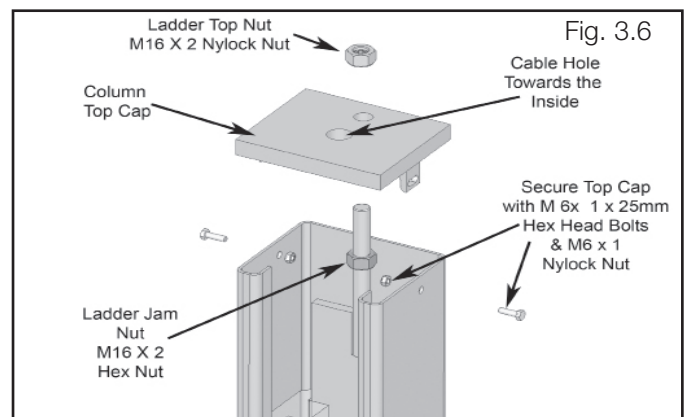
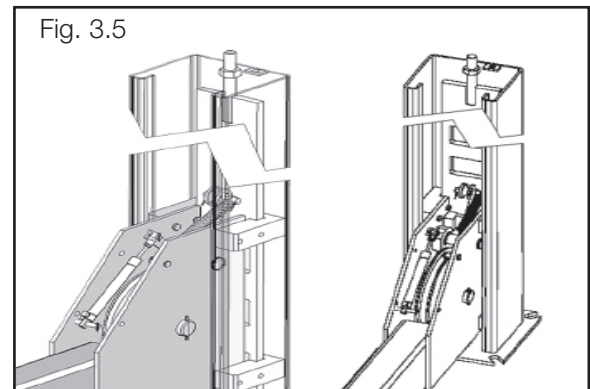
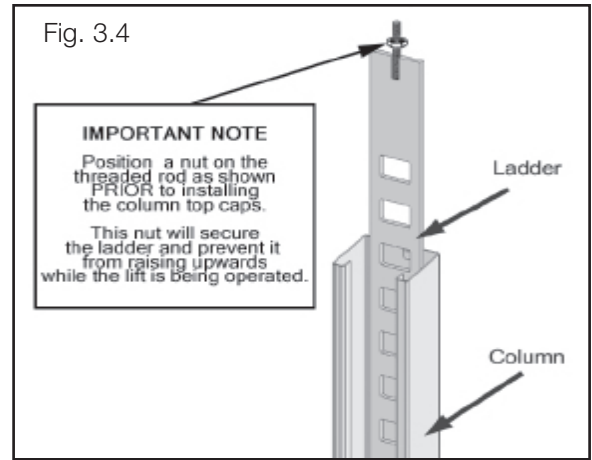

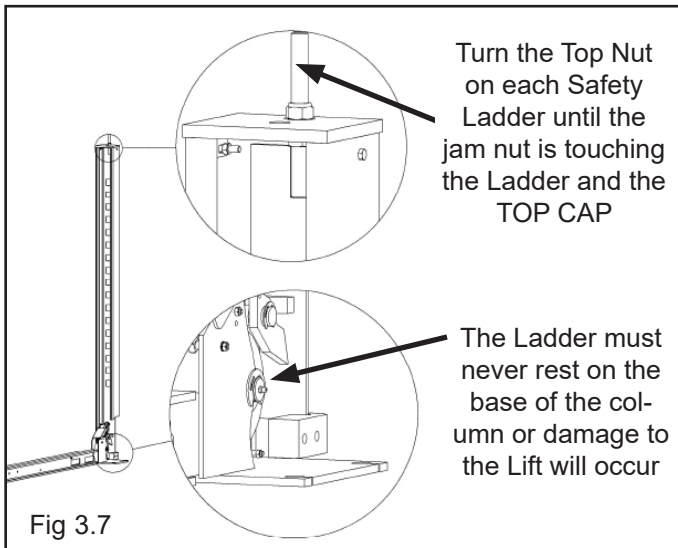

STEP 4

(Anchoring The Columns)

1. Before proceeding, double check the measurements and make certain that the Bases of each Column are square and aligned with the chalk line. (See Fig. 4.1)

ALWAYS WEAR SAFETY GOGGLES

2. Using the Base Plate on each Column as a guide, drill each anchor hole approximately 4-1/2" deep using a rotary hammer drill and 3/4" concrete bit. (See Fig. 4.2)

3. After drilling, remove dust thoroughly from each hole using compressed air and/or bristle brush. Make certain that the Columns remain aligned with the chalk line.

4. Assemble the Washers and Nuts on the Anchors then tap into each hole with a hammer until the Washer rests against the Base Plate. Be sure that if shimming will be required, enough threads are left exposed. (See Fig. 4.3)

5. If shimming is required, insert the Shims as necessary under the Base Plate so that when the Anchor bolts are tightened, the Columns will be plumb using a 4-foot level.

6. After any necessary Shims are installed, tighten each anchor nut three to five turns past finger tight. (See Fig. 4.5) **IMPORTANT** - If Anchor Bolts do not hold when torqued to 85-90 ft. lbs., concrete must be replaced. Saw cut and remove 24" x 24" square area under each Column base then re-pour with reinforced 4,000 PSI concrete to a depth of six inches minimum, keying new concrete under existing floor.

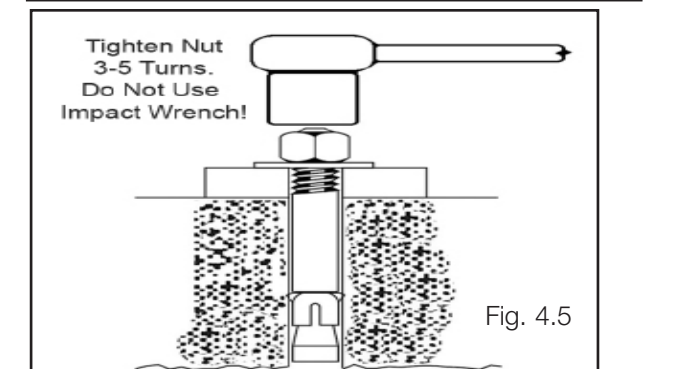
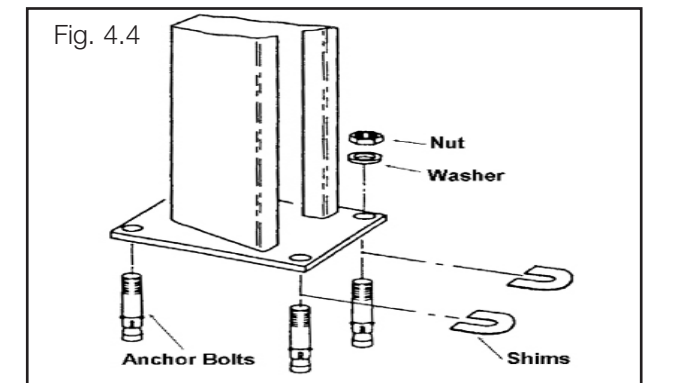
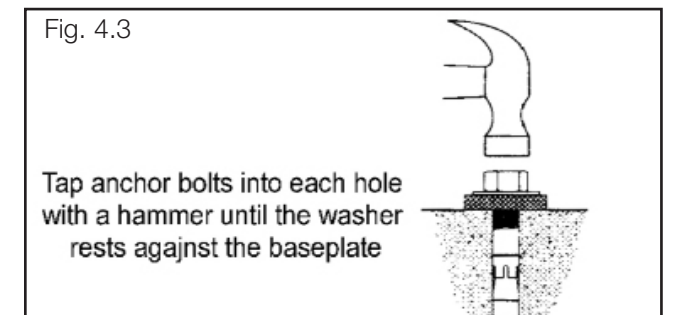
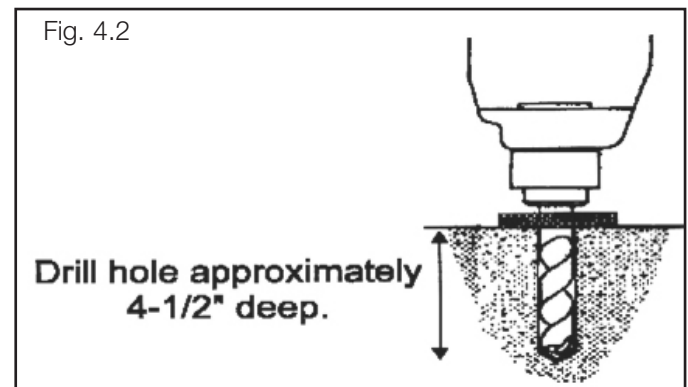
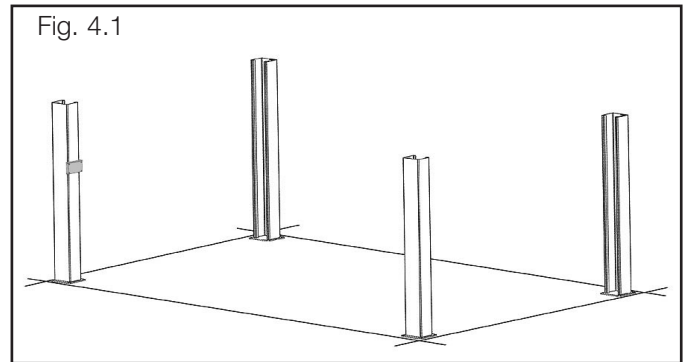

IMPORTANT NOTE:
BendPak Lifts are supplied with installation instructions and concrete fasteners meeting the criteria as prescribed by the American National Standard "Automotive Lifts - Safety Requirements for Construction, Testing, and Validation" ANSI/ALI ALCVT. Lift buyers are responsible for any special regional structural and/or seismic anchoring requirements specified by any other agencies and/or codes such as the Uniform Building Code (UBC) and/or International Building Code (IBC).

STEP 5

(Raising The Cross Tubes)

1. It is necessary to first raise the Cross Tubes off the ground to facilitate Cable routing and final assembly.



ENSURE THAT THE FRONT POST UPPER AND LOWER SLIDE BLOCKS ARE ORIENTED AS SHOWN IN FIGURE 3.3 ON PAGE 13. BEFORE PROCEEDING.

2. Manually raise the Cross Tubes until the primary Safety Locks engage and rest on the lock position second down from the top of the ladder or approximately 6'6" off the ground. It is important that the SLACK SAFETY LOCK IS CLEARED. The Slack Safety Lock must never rest on the Safety Ladder. See Figs. 5.1.

3. The Columns and Cross Tubes will now be in position and spaced properly for the Runways. (See Fig. 5.2)

IMPORTANT NOTE

It is important that the SLACK SAFETY LOCK IS CLEARED.
The slack safety lock must never rest on the safety ladder.

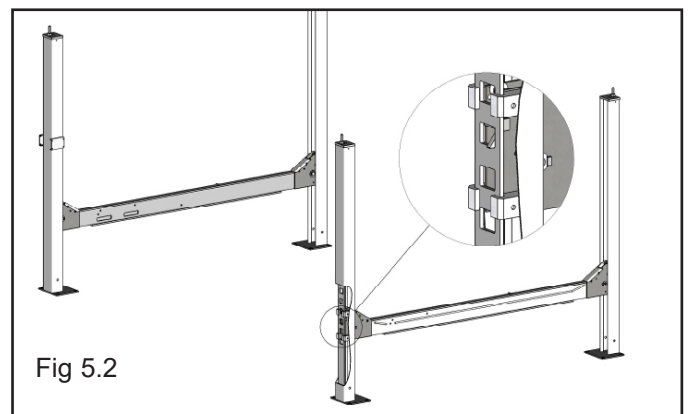
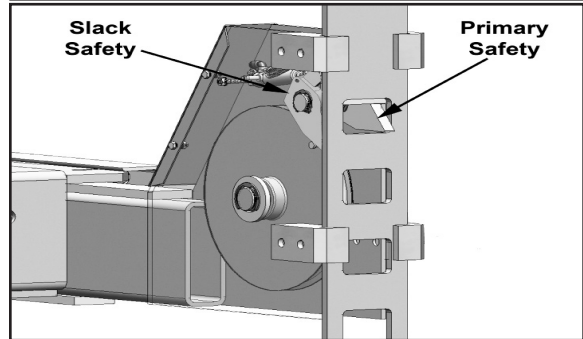
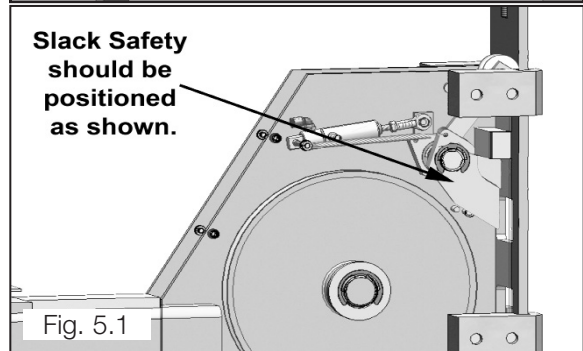
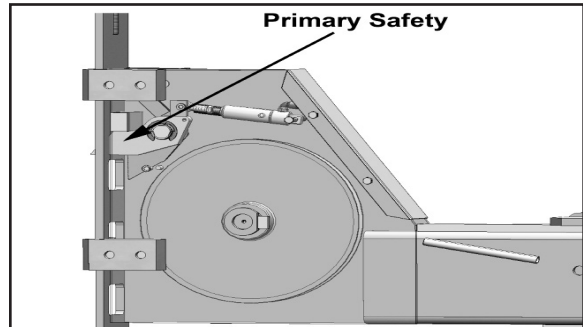

STEP 6

(Powerside Runway Installation)

1. Locate the Powerside Runway easily identified by the Cylinder and Sheave Roller mounting structures welded on the underside. The Powerside Runway will be positioned on the side of the Lift where the Power Unit is installed.

(See Fig. 6.1)

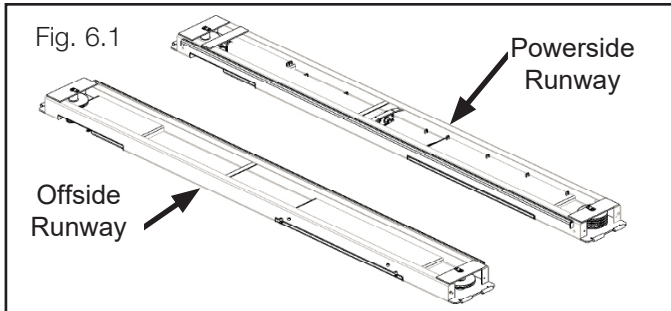

2. . Remove any pre-installed Cable Sheaves from the Powerside runway making sure to pay attention to the order in which they are removed.



ENSURE THAT THE FRONT POST UPPER AND LOWER SLIDE BLOCKS ARE ORIENTED AS SHOWN IN FIGURE 3.3 ON PAGE 12. BEFORE PROCEEDING.

3. Position the Powerside Runway on top of the Cross Tubes with the utility rail towards the center. The fitting holes located at the side of the Powerside Runway should be adjacent to the Power Unit Column.

4. Align the holes in the Runway with the holes on the Cross Tubes and bolt it into place using four M12 x 7.75 x 90 Hex Head Bolts and Washers. (See Fig. 6.2)

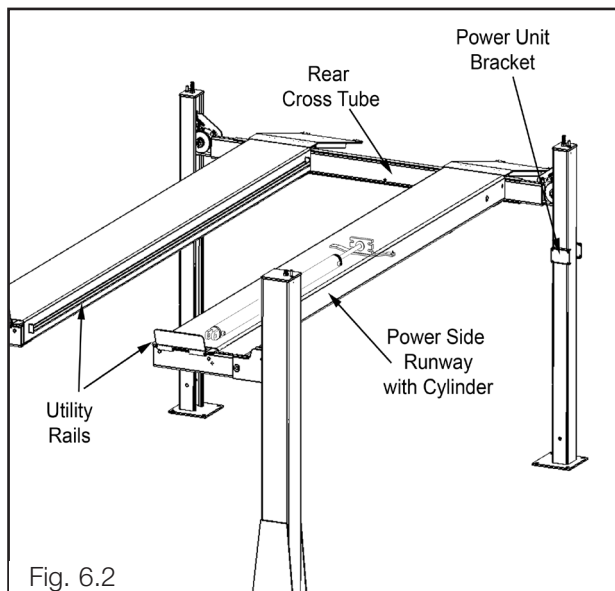

STEP 7

(Offside Runway Installation)

1. Position the Offside Runway on top of the Cross Tubes with the utility rail located inside. (See Fig. 7.1)

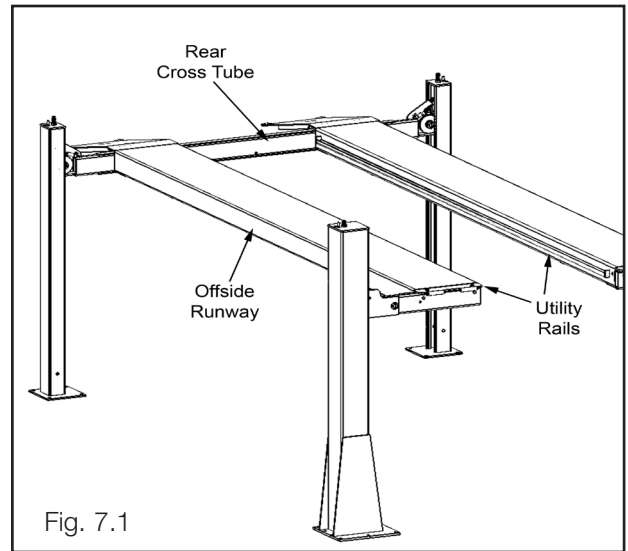

DO NOT PROCEED with cable installation or go near the Lift work area unless visual confirmation is made of ALL safety locks. ALL locks MUST be engaged before proceeding. Failure to comply with these instructions may result in severe personal injury or death. (See page 15.)

STEP 8

(Cable / Sheave Installation)



DO NOT PROCEED unless visual confirmation is made of ALL safety locks. ALL locks MUST be engaged before proceeding. Failure to comply with these instructions may result in severe personal injury or death. (See page 15)

1. Inspect Cables to ensure proper lengths. All Cables should have ID tags showing proper Cable lengths.

2. In order to install the Cables it is necessary to first extend the Hydraulic Cylinder. Remove **both Cylinder Port Plugs** then use an air gun or come-along to extend the Cylinder.

IMPORTANT! - Be careful not to damage the chrome rod during this step. (See Fig. 8.1)

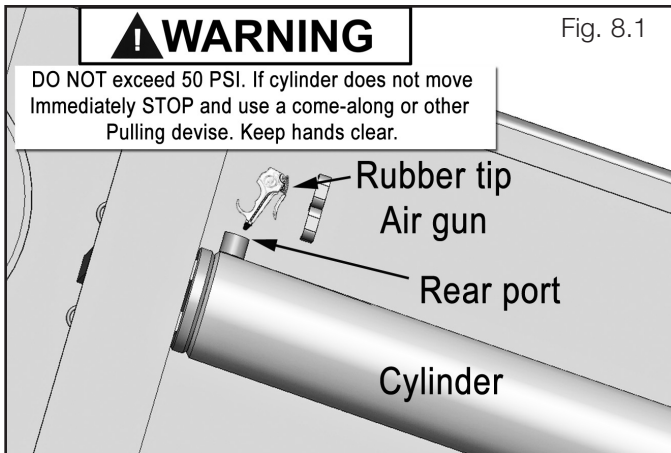

3. Loosely route the Cables around the Sheaves, (refer to the diagram on page 16), and then lubricate with red lithium grease and install the Sheave Pin and screw in the Sheave Pin Retaining Screw. (It may be necessary to loosen the Sheave Pin and move or adjust the pulleys during cable installation.) (See Fig. 8.2)

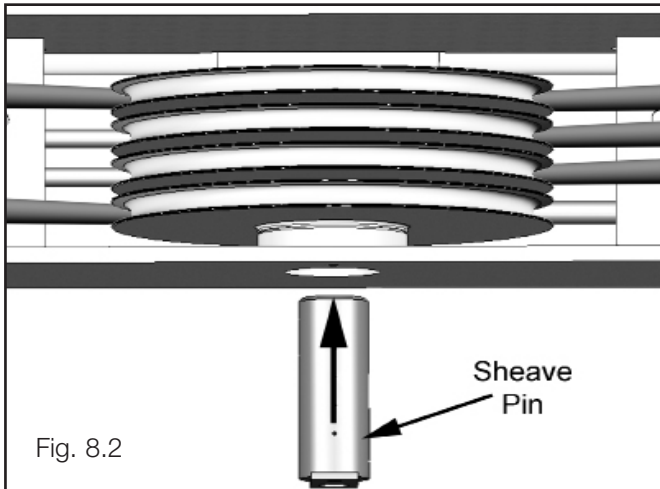

STEP 9

(Cable Installation)



Failure to route Lifting cables as described may lead to serious personal injury and/or death to operator or bystander and/or may cause damage to property.



WHEN THE CABLE ADJUSTING NUTS BOTTOM OUT ON THE THREADED END OF THE CABLE CONNECTOR AND THERE IS STILL SLACK IN THE CABLES, THE CABLES HAVE STRETCHED BEYOND THE SAFE USEFUL LENGTH AND NEED TO BE REPLACED WITH FACTORY APPROVED CABLE ASSEMBLIES. DO NOT PLACE WASHERS, SPACERS OR OTHER DEVICES TO "SHORTEN" THE EFFECTIVE CABLE LENGTH AS DAMAGE TO THE Lift OR INJURY TO PERSONS MAY OCCUR.

1. Make sure the Cylinder Flange Plate is installed with the guide assembly facing down and the Cylinder retainer plate on the outside of the guide. Lug ends of cables start at Cylinder. (See Fig. 9.1)

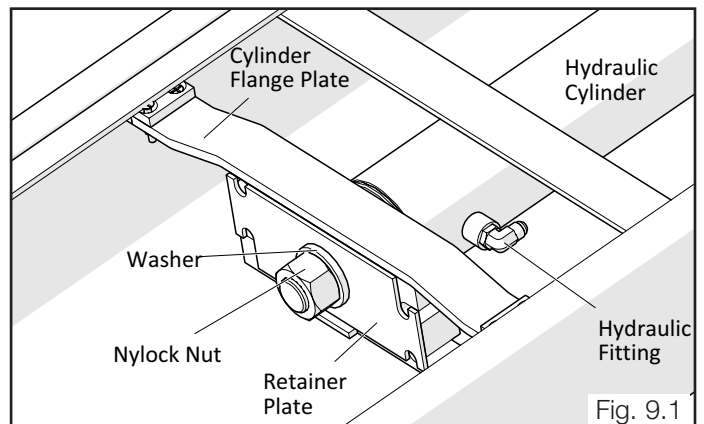

2. Route the threaded Cable ends through the ends of each Cross Tube, over the Slack Safety Sheave then to the top of each Column. Secure using the M22 Hex Head Nuts and Flat Washers. Tighten each nut until there is at least one inch of threads protruding through the top of the Nut. The Cables will remain loose until start up and final Cable adjustments are made. (See Fig. 9.2 - 9.3)

HDSO-14P/14AX CABLE ROUTING

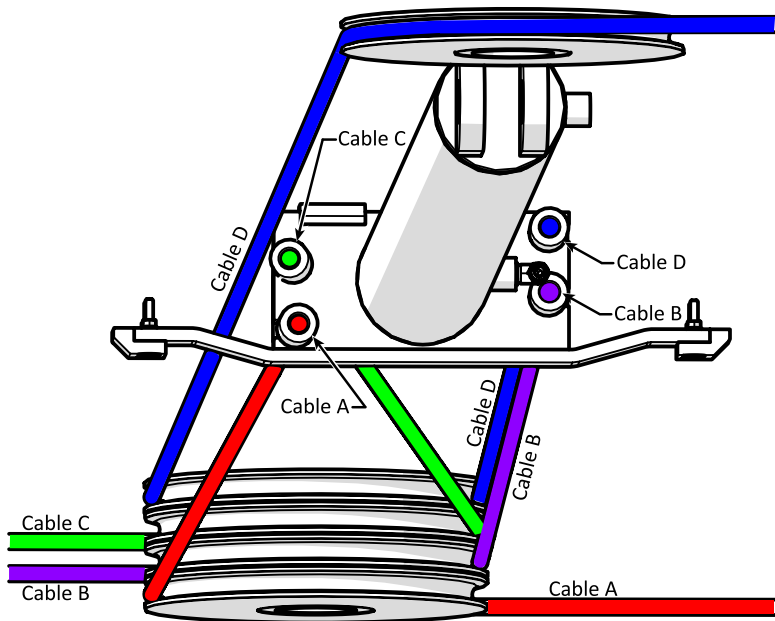
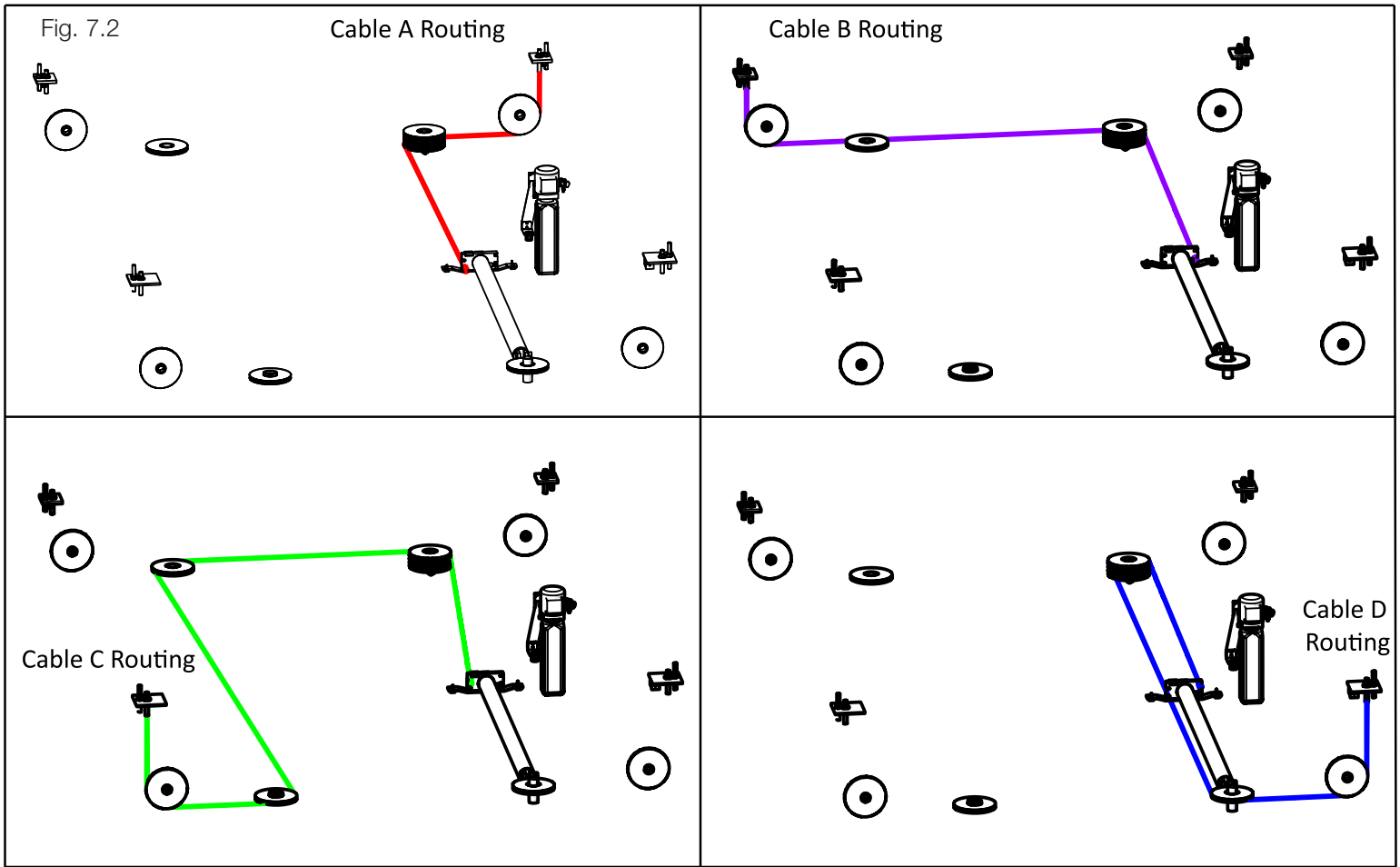

IMPORTANT

Lubricate Pins and Sheave Bores with Red Lithium Grease prior to installing.

Spacers on the single sheaves are sized specifically for their location; they are different heights from the spacers at the other locations.

If you remove a sheave pin, sheave, and spacers at any location, replace them at the same location in the exact same orientation.

	Model	Part #	Description
A	HDSO-14P/14AX	5595065	HDSO-14P/14AX/14LSXE, HDS-14X CABLE ASSEMBLY Ø12 x 4,100 mm ST
B	HDSO-14P/14AX	5595066	HDSO-14P/14AX/14LSXE, HDS-14X CABLE ASSEMBLY Ø12 x 5,732 mm ST
C	HDSO-14P/14AX	5595089	HDSO-14P/14AX CABLE ASSEMBLY Ø12 x 11,302 mm ST
D	HDSO-14P/14AX	5595931	HDSO-14P/14AX CABLE ASSEMBLY Ø12 x 9,639 mm ST

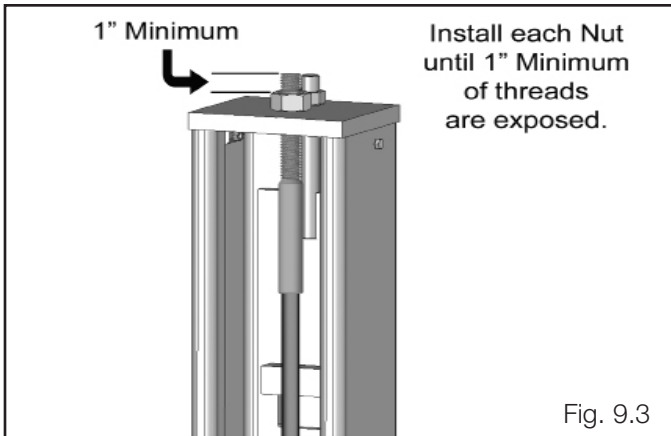
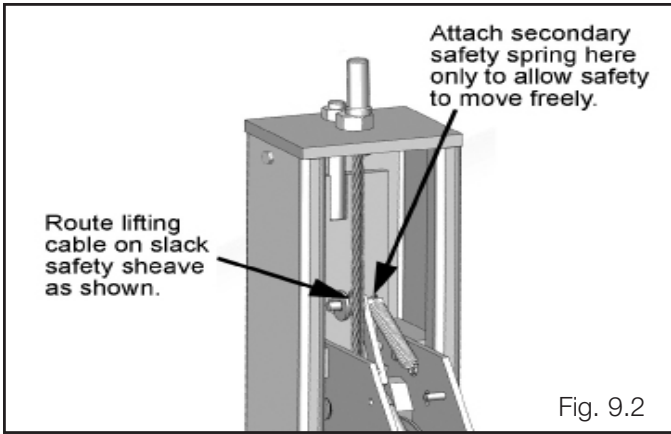

3. After routing the Cables double-check to make sure all are properly positioned and remain within the grooves of ALL Sheaves. (See Fig. 9.4 - 9.5)

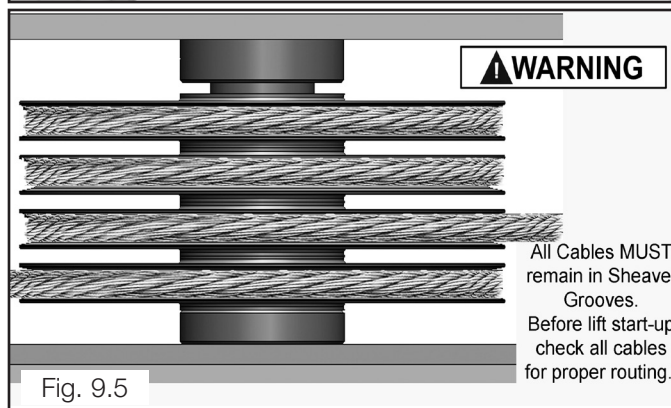
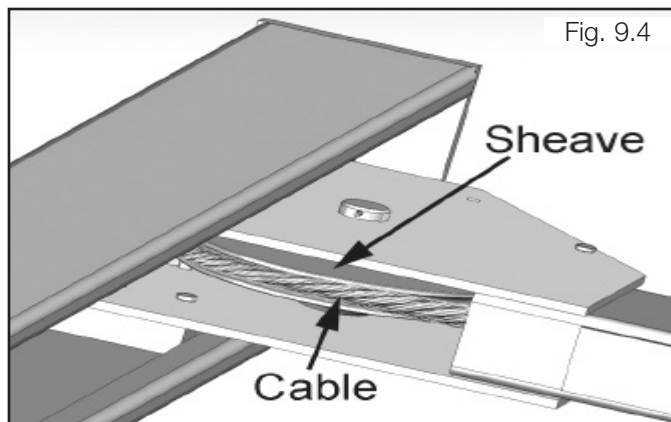

STEP 10

(Power Unit Installation)

1. Mount the Power Unit, Air Valve Mounting Bracket, Vibration Dampner, and Flex Tube Mounting Bracket to the Power Unit Mounting Bracket using the M8 hex bolts and Nylock Nuts. Fill the reservoir with 12 quarts of 10-WT hydraulic oil or Dexron automatic transmission fluid. (See Fig. 10.1)

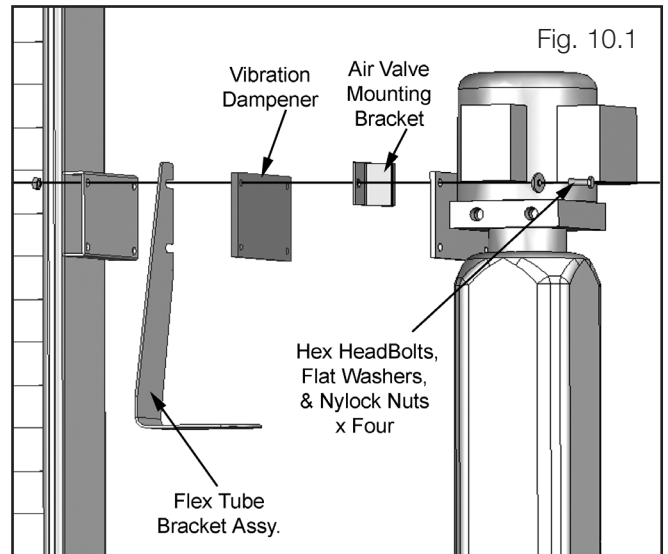

ALL WIRING MUST BE PERFORMED BY A LICENSED ELECTRICIAN.



DO NOT PERFORM ANY MAINTENANCE OR INSTALLATION OF ANY COMPONENTS WITH OUT FIRST ENSURING THAT ELECTRICAL POWER HAS BEEN DISCONNECTED AT THE SOURCE OR PANEL AND CANNOT BE RE-ENERGIZED UNTIL ALL MAINTENANCE AND/OR INSTALLATION PROCEDURES ARE COMPLETED.

The standard Power Unit for your Lift is 220 volt, 60HZ, single phase. All wiring must be performed by a licensed certified electrician only.

PROPER WIRING INSTRUCTIONS ARE AFFIXED TO MOTOR.



DO NOT run Power Unit with no oil. Damage to pump can occur.
The Power Unit must be kept dry. Damage to Power Unit caused by water or other liquids such as detergents, acid etc., is not covered under warranty.

Operate Lift only between temperatures of +41 ° to +104° F.

Improper electrical hook-up can damage motor and will not be covered under warranty.

Motor can not run on 50HZ without a physical change in motor.

Use a separate breaker for each Power Unit.

Protect each circuit with an appropriate time delay fuse or circuit breaker.

STEP 11

(Routing Hydraulic Hoses)

1. Install the 90-degree Hydraulic Fitting to the POWER PORT and the 90° Air Line Compression Fitting to the RETURN PORT of the Power Unit and connect the Hoses as described below. It will be necessary to remove the shipping plugs from both ports prior to installing the Fittings. (See Fig. 11.1 - 11.2)

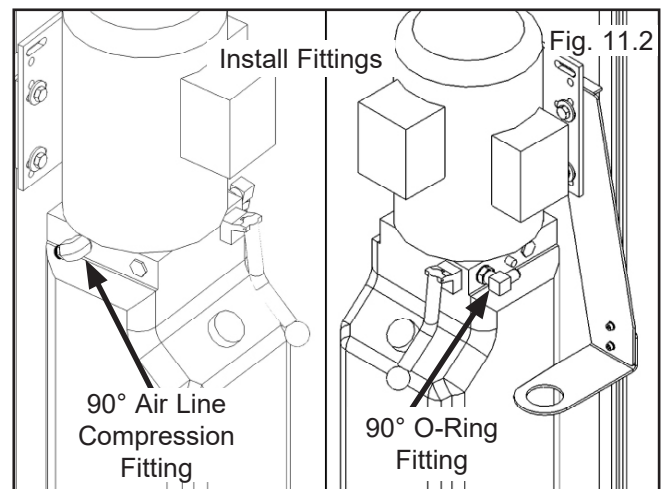
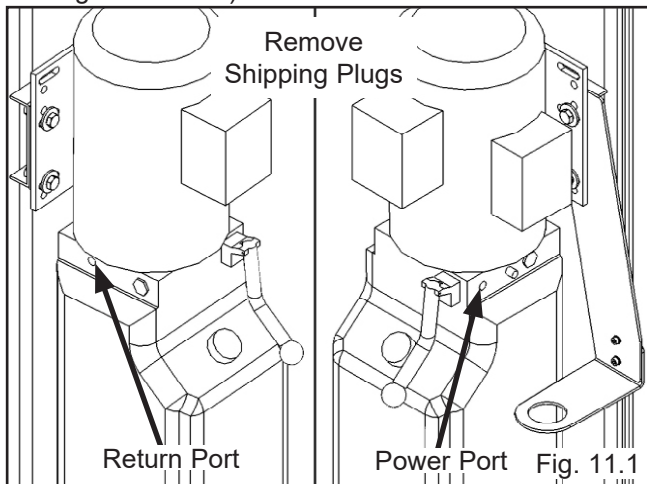

NOTE: Return Port may be on the same side as the Power Port on some models.

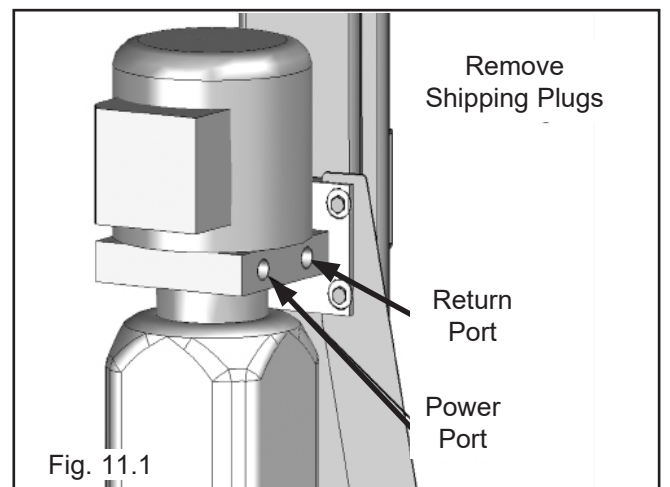

NOTE:

Check the Power Unit to determine proper connection ports for Power and Return lines. It will be necessary to remove shipping plugs from both ports prior to installing Fittings.

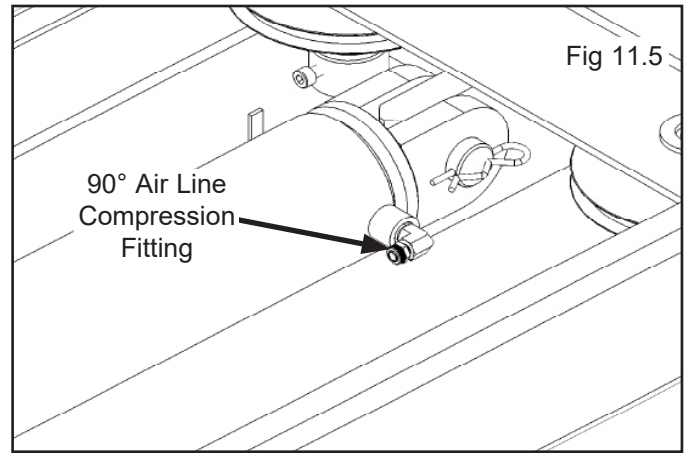
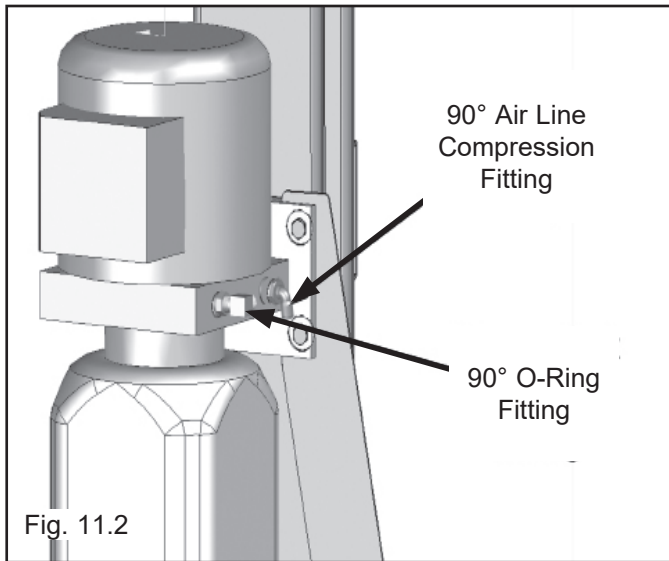

2. Remove the captive nut on the Compression Fitting. Insert the Plastic Air line through the alignment sleeve and into the end of the fitting until it bottoms out. Then tighten the nut on the fitting. (See Fig 11.3)

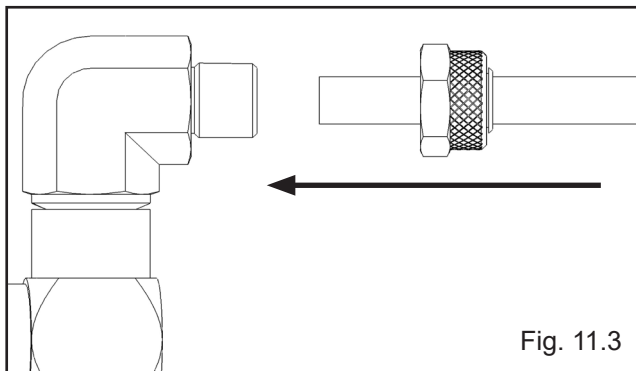

3. Install the 90-degree Hydraulic Fitting in the port at the ram end of the Cylinder. On the pipe thread side of the Fitting it is recommended to use Teflon Tape or pipe sealer. **DO NOT USE TEFLON TAPE on the JIC flared end.** Apply Sealer between +46.5°F to +70°F (+8°C to 21°C) (See Fig. 11.4)

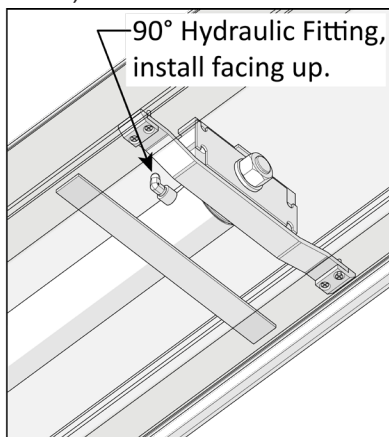

4. Install the 90-degree Air Line Compression Fitting in the port at the base, pinned end of the Cylinder. On the pipe thread side of the Fitting, it is recommended to use Teflon Tape or pipe sealer. (See Fig. 11.5)

5. Cut the Flex tube to 52 in. ±1in. / 1320mm ±25mm long. Route both the Power Unit Hydraulic Hose and TWO (2) lengths of Air Line through the Flex Hose. (See Fig. 11.6)

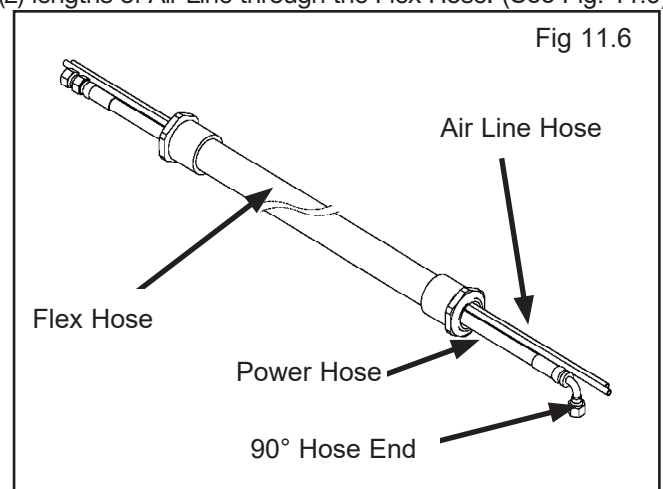

6. **Install the end of Flex Hose with the Straight Fitting on the Hydraulic Hose into the hole in the Powerside Runway adjacent to the Power Unit. Install the end of the Flex Hose with the 90° Fitting on the Hydraulic Hose in the Flex Hose Bracket Assy. Tighten the plastic nuts securely.**

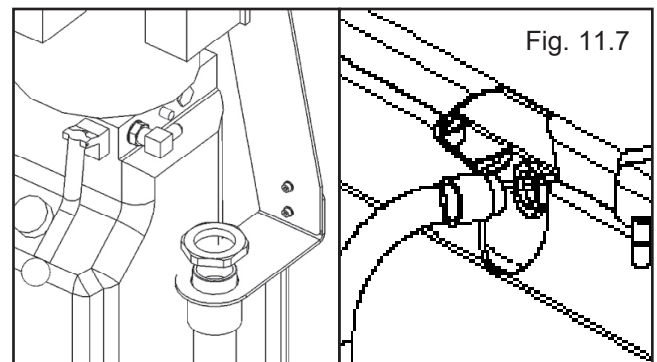

(See Fig 11.7)

7. Connect the hydraulic hose and air line as shown below making sure the hydraulic hose passes through the retaining rings. **MAKE SURE HOSES ARE KEPT CLEAR OF CABLES.** There will be one air line hose left unconnected in this step. This air line will be used to activate the pneumatic safety locks in the next step. See page 19 for Compression Fitting instructions. (See Fig. 11.8)

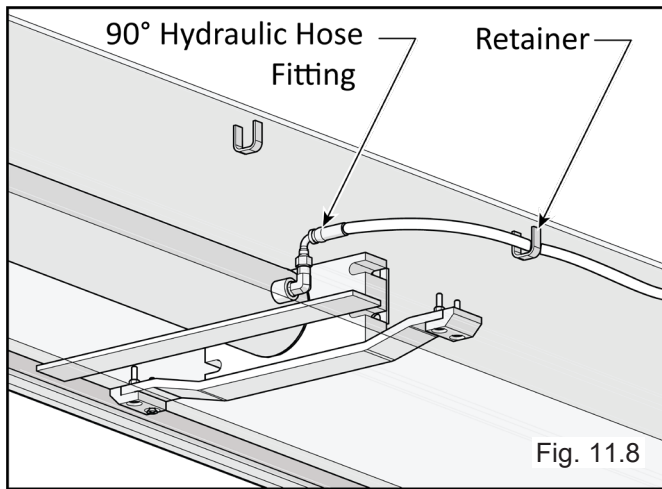

8. Connect the straight end of the Power Unit Hydraulic Line to the 90° Power Unit Fitting. Connect the Return Air Line to the 90° Air Fitting. There will be one air line hose left unconnected at this time. This air line hose will be used to activate the pneumatic safety locks on the next page.

(See Fig. 11.9)

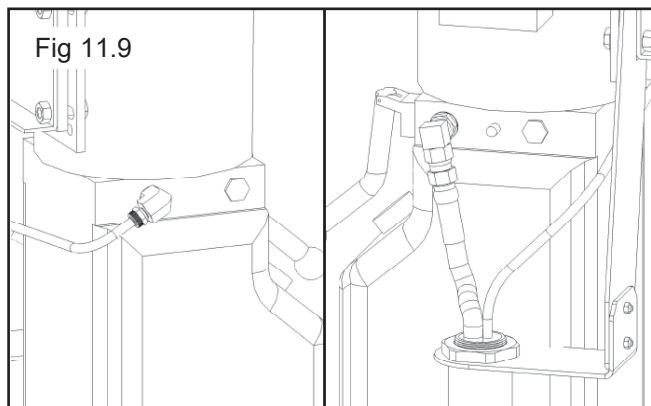

STEP 12 (Routing Air Lines)

1. Mount the Push Button Air Valve Assembly on to the power unit mounting bracket. The Push Button Air Valve should be positioned away from the Power Side Ramp on the “out” side of the Lift for operator safety. (See Fig 12.1)

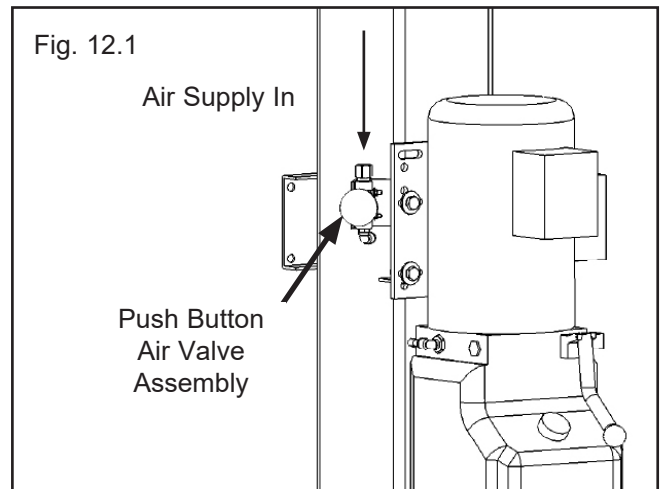

2. Route the air line that was left unconnected in Step 10 to the 90° Air Line Compression Fitting of the Push Button Air Valve Assembly. (See Fig 12.2)

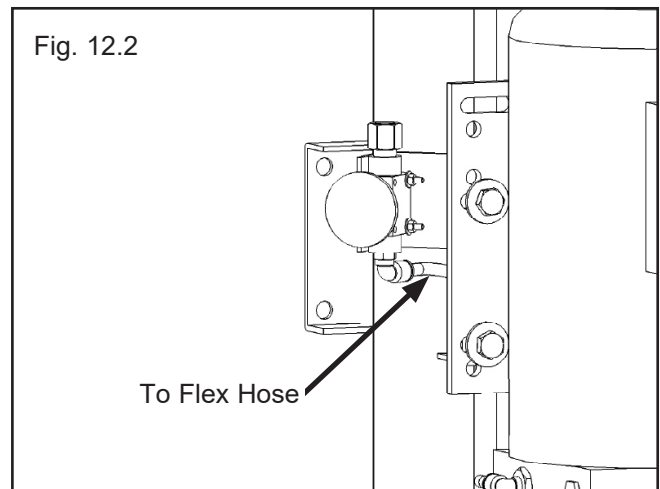

3. Once the air line has been connected with the Push Button Air Valve, cut the air lines to length by following the Safety Air Line Routing diagram located on Page 22 and connect female branch “tee” fittings where needed.

NOTE:
MAKE SURE THE PUSH BUTTON AIR VALVE PORT MARKED “INLET” IS FACING TOWARDS THE SOURCE OF COMPRESSED AIR.

NOTE:
A FILTER/REGULATOR/LUBRICATOR MUST BE INSTALLED ON AIR SUPPLY AT Lift. FAILURE TO DO SO WILL VOID THE WARRANTY.

SAFETY AIR LINE ROUTING

NOTE:

CUT THE PROVIDED 1/4" AIR LINE TUBING WITH A SHARP BLADE TO LENGTHS AS REQUIRED. TUBING MUST BE CUT SQUARE WITH ALL PLASTIC BURRS REMOVED.

AIR TUBING ASSEMBLY:

SEE PAGE 19 FOR ASSEMBLY OF AIR LINE TUBING INTO FITTING.

CAUTION:

REMOVING THE AIR TUBING FROM THE COMPRESSION FITTINGS WILL CAUSE DAMAGE TO THE TUBING ITSELF. USE OF A DAMAGED AIR LINE MAY RESULT IN SAFETY LOCK FAILURE.

AIRLINE ROUTING

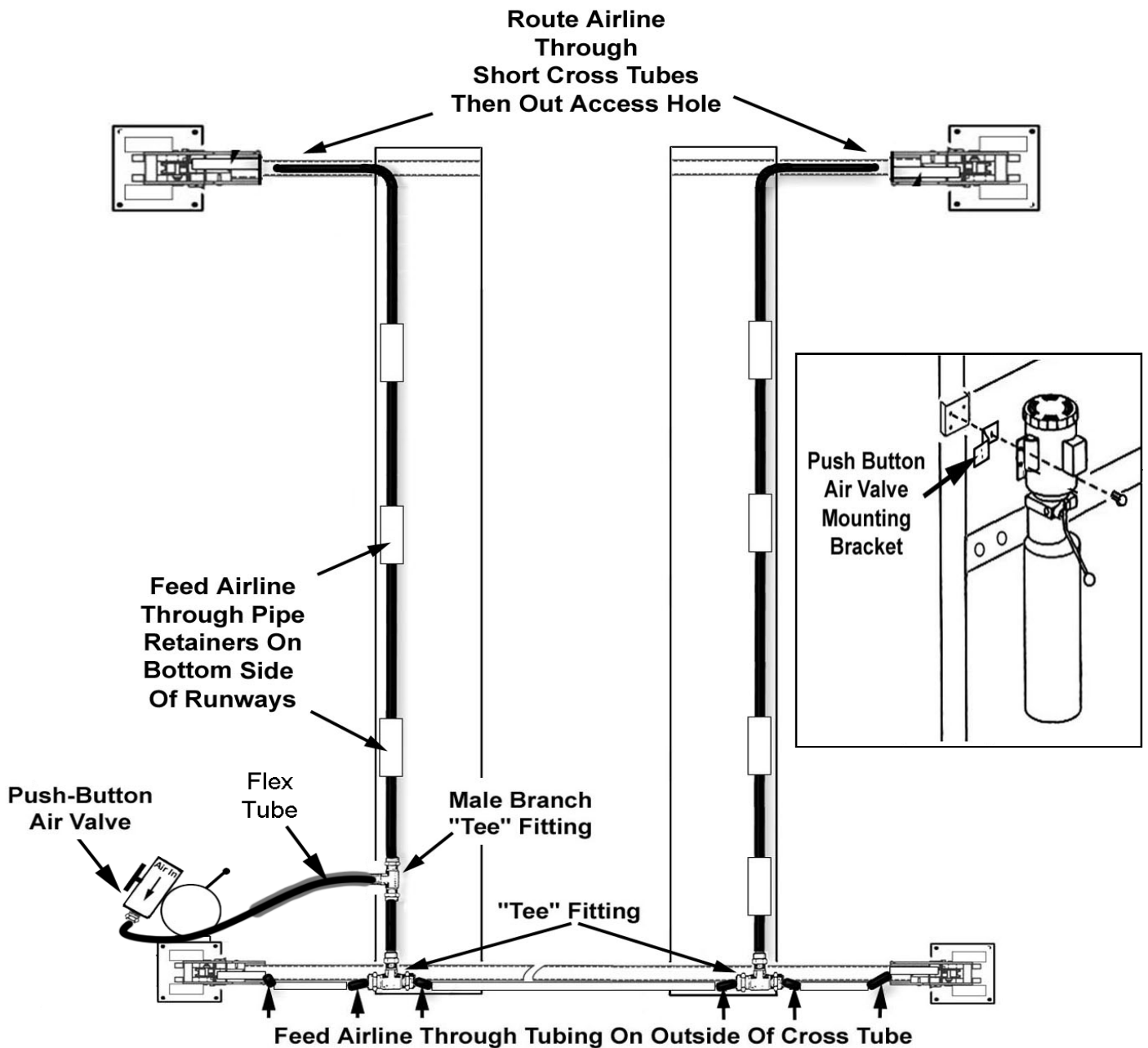



IMPORTANT! PLEASE READ NOW



Hydraulic Fluid Contamination

Hydraulic Fluid Contamination poses a serious issue for your Lift; contaminants such as water, dirt, or other debris can get into the Hydraulic Hoses and Fittings on your Lift, making your new Lift inoperable and unusable.

Your Lift is shipped with clean components; however, BendPak strongly recommends that you take secondary precaution and clean all Hydraulic Hoses and Fittings prior to making connections. It is better and less costly to take these extra steps now so that you do not need to take your Lift out of service later to fix issues that could have been prevented at the time of the installation.

There are several ways to clean Hydraulic Hoses and Fittings:

- Compressed air. Use an air compressor to blow out contaminants from each Hydraulic Hose and Fitting prior to installation. Clean, dry air is preferred. Wear eye protection (safety glasses, goggles, or face shield) when using compressed air for cleaning. Never point an air hose nozzle at any part of your body or any other person.
- Fluid flushing. As long as the Hydraulic Fluid is clean and compatible with the system fluid, you can flush Hoses and Fittings to create turbulent flow and remove particulates. Always ensure that the fluid itself is contaminant-free.

Some additional steps that will help keep the Hydraulic Fluid clean:

- Remove old thread seal tape. Some ports on the Hydraulic Cylinders are shipped with temporary plugs secured with thread seal tape, so make sure to thoroughly remove any leftover thread seal tape that may inadvertently enter the Hydraulic System.
- Use a liquid thread sealant only. Teflon paste-type thread sealant or Loctite™ 5452 thread sealant is recommended for all NPT Fittings. Do not over tighten NPT Fittings or they may crack. Do not use thread seal tape on flare-end JIC 37-degree bevel Fittings or ORB O-Ring Fittings. Apply the thread sealant when the ambient temperature is between +46.5°F to +70°F (+8°C to 21°C)
- Always use clean equipment. If you use a dirty bucket or funnel to transfer the Hydraulic Fluid into the Hydraulic Fluid Reservoir, the contaminants will likely be introduced into the Fluid. When using cleaning rags, use a lint-free rag.
- Proper storage. Keep the Hydraulic Fluid sealed in its container until ready for use. Store the Fluid in a clean, dry, and cool area.
- Cover the Hoses and Fittings. Before installation, do not leave the ends of the Fittings exposed; the same applies for Hydraulic Hoses. As a general rule, keep the Hydraulic Hoses and Fittings capped and kept in a clean area until ready for use.
- Filter the new Hydraulic Fluid. Just because it is new does not necessarily mean it is clean. Use an offline filtration cart or kidney loop system to make sure the Hydraulic Fluid is clean before being transferred into the Reservoir (even using a heavy duty nylon mesh screen is better than trusting what is left at the bottom of the barrel).
- Avoid mixing different types of Hydraulic Fluid. If Hydraulic Fluid needs to be replaced, make sure to flush the Hydraulic System of the old Hydraulic Fluid before you add the replacement fluid; do not mix the two together.



Hydraulic System Warnings

Before applying power to the Hydraulic System note the following Warnings:

Failure to observe these warnings can result in serious personal injury including, in rare cases, death.

- The Hydraulic hoses and connections must be inspected before any attempt to raise a Vehicle is made.
- Verify all Hydraulic Hose connections and fittings, including unused auxiliary port plugs on the Power Unit, the Flow Divider, the Cylinders and anywhere else in the Hydraulic System are tightened.
- The Power Unit is a Hydraulic Pump capable of developing pressures in excess of 5,000 psi (345 BAR). A pressure relief valve is used to set the pressure at the desired level. Tampering with, adjusting, modifying, or removing the relief valve is extremely dangerous and is not permitted. Only trained Hydraulics Technicians should make adjustments to the relief valve, using calibrated hydraulic pressure gauges to ensure the proper pressure setting is achieved.
- Changes to the output pressure may render the power unit incompatible with pressure limitations of other components in the hydraulic circuit. This may cause catastrophic failure of those components, and could result in property damage, serious personal injury or death.
- The Hydraulic System can contain high pressure which, if suddenly released, can cause serious injury or death.
- Do not attempt to connect or disconnect Hydraulic Hoses while the equipment is loaded or while a Vehicle is on the Lift or the Hydraulic System is under pressure.
- Keep bare hands away from Hydraulic Fluid; always wear gloves when handling Hydraulic Fluid, Cylinders or Hydraulic Hoses.
- When handling Hydraulic Fluid, always observe the safety instructions from the manufacturer.
- Always promptly clean any Hydraulic Fluid spills. If a leak is the source of the spill, lockout the Lift to prevent use until the Hydraulic System is repaired.
- Do not attempt to service the Power Unit through the rear panel. Only access the Power unit through the Front of the Console.



DO NOT PERFORM ANY MAINTENANCE OR INSTALLATION OF ANY COMPONENTS WITHOUT FIRST ENSURING THAT ELECTRICAL POWER HAS BEEN DISCONNECTED AT THE SOURCE OR PANEL AND CANNOT BE RE-ENERGIZED UNTIL ALL MAINTENANCE AND/OR INSTALLATION PROCEDURES ARE COMPLETED.



IMPORTANT POWER-UNIT INSTALLATION NOTES

- The Electrician must install a **Power Disconnect Switch** and a **Thermal Disconnect**. This equipment is not included with the Lift and must be supplied and installed by the Electrician. This is a National Electrical Code (NEC) Requirement.
- Each Power Unit circuit must be protected with a time delay fuse or circuit breaker.
- Electrician is to verify facility wiring is correctly rated and protected for the voltage and load presented by the Power Unit. Wiring of motor, control overload protection and grounding must meet national and local codes.
- Use a separate circuit breaker for each power unit.
- DO NOT run power unit without oil. Damage to the pump will occur.
- The power unit must be kept dry. Damage to the power unit caused by water or other liquids such as detergents, acid etc., is not covered under warranty.
- Improper electrical hook-up can damage the motor and will not be covered under warranty.
- Motor can not run on 50Hz without a physical change in the motor.

**ALL WIRING MUST BE PERFORMED BY A LICENSED ELECTRICIAN ONLY
IN ACCORDANCE WITH LOCAL, STATE, AND NATIONAL ELECTRICAL
CODES.**

Multiple power units will function with this Lift and the power unit delivered with the Lift may not be described in this manual. Identify which Power Unit the Lift by reviewing the data tag affixed to the Power Unit motor. Two common Power Units are described on the next page. Always review the wiring diagram and electrical specifications on the Power Unit to verify compatibility with the facility electrical service. At 220VAC a 25 Amp Circuit breaker is recommended.

SPECIFIC WIRING INSTRUCTIONS ARE AFFIXED TO THE MOTOR.

Installation and adjustment.

DO NOT attempt to raise a Vehicle until a thorough operational check has been completed.

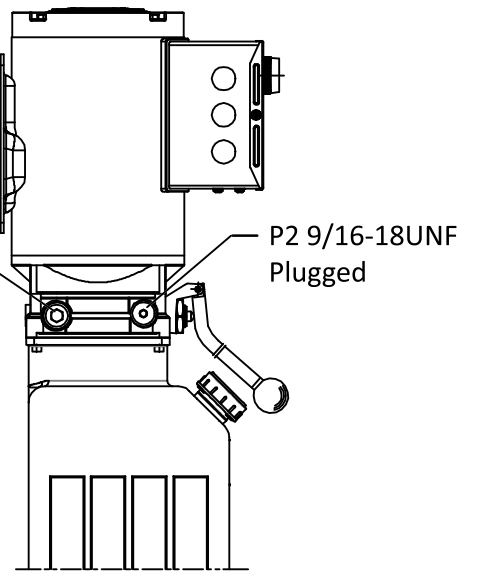
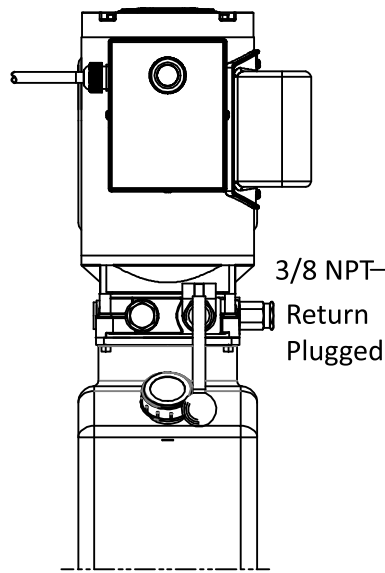
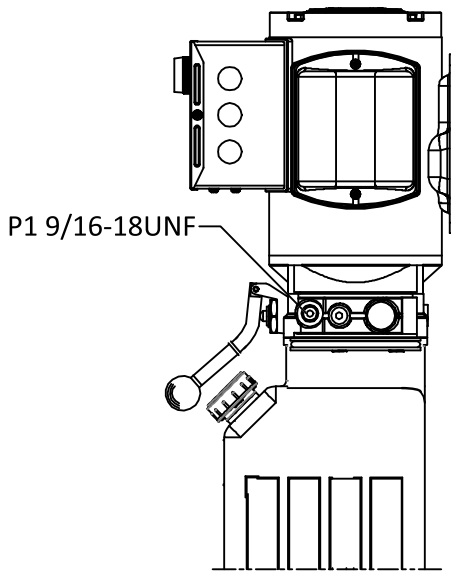

Power Unit 5585016
208-240VAC, 50/60HZ, 1 Ph.
3 HP, 2900/3450 RPM

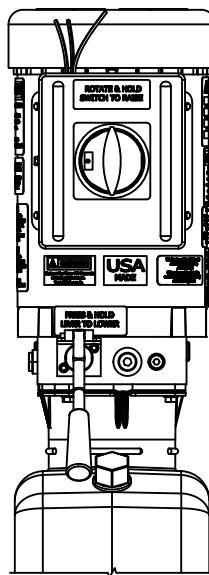
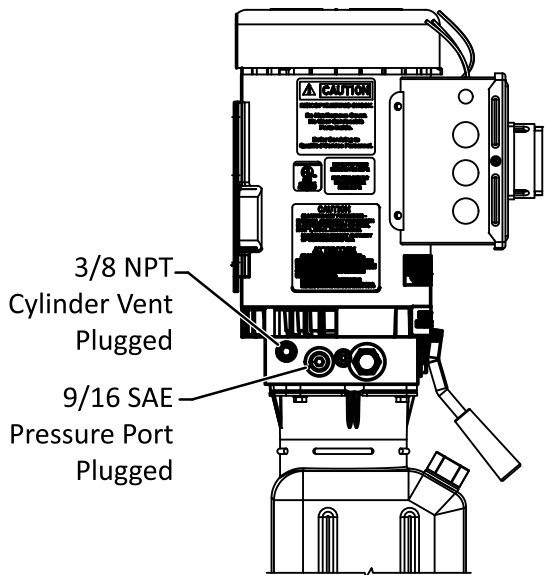
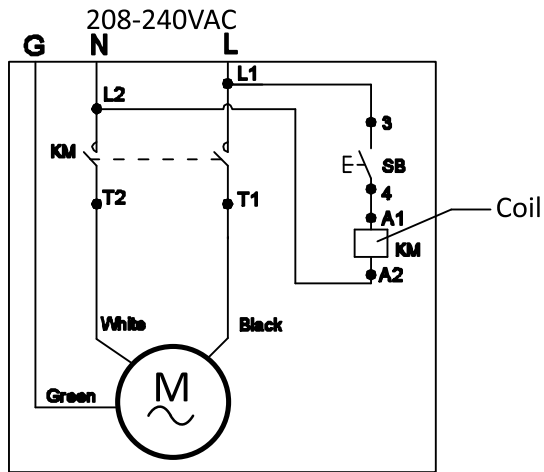

Power Unit 5585182
460VAC, 60 Hz.
2 HP, 3 Ph

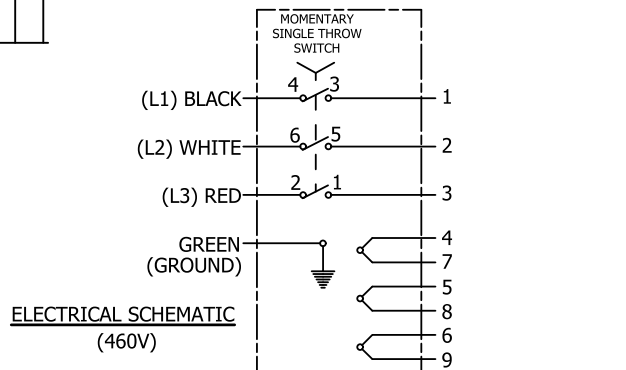
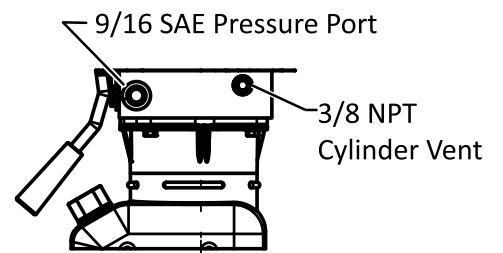

STEP 13

(Power Unit Hook Up)

1. Have a licensed electrician run the facilities' Power Supply to the motor. Refer to the data plate found on the motor for proper power supply and wire size.



RISK OF EXPLOSION

This equipment has internal arcing or parts that may spark and should not be exposed to flammable vapors. Motor should not be located in a recessed area or below floor level. NEVER expose the motor to rain or other damp environments. **DAMAGE TO THE MOTOR CAUSED BY WATER IS NOT COVERED UNDER WARRANTY.**

IMPORTANT NOTE:

CAUTION Never operate the motor on line voltage less than 208V. Motor damage may occur which is not covered under warranty. Have a licensed electrician run an appropriate power supply to the motor. Size wire for the voltage and current indicated on the Data Plate. See Motor Operating Data.

IMPORTANT: Use separate circuit for each power unit. Protect each circuit with time delay fuse or circuit breaker. All wiring must comply with NEC and all local electrical codes.

Fig. 13.1

POWER UNIT

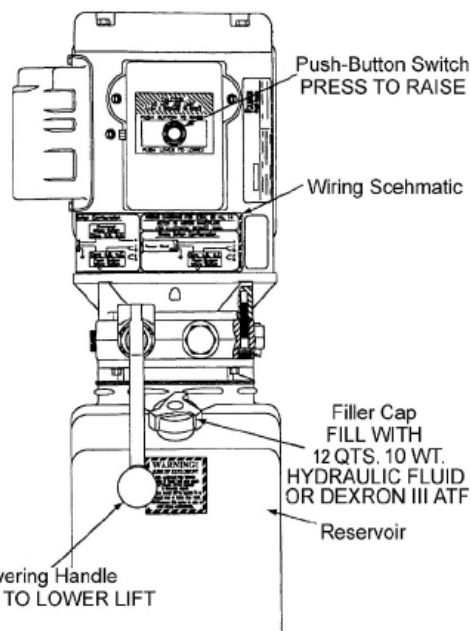

STEP 14

(Inspecting The Slack Safety Springs)



The following steps involve the SLACK CABLE SAFETY DEVICE and MAIN SAFETY. Failure to follow these steps could result in serious injury or death in the event of cable failure.

1. Inspect the ends of the ALL SAFETY LOCK SPRINGS as shown. Make sure the spring ends are secure at both ends. **DO NOT ATTEMPT TO RAISE THE Lift UNTIL THE SLACK SAFETY SPRINGS ARE ATTACHED AND THE ROLLERS ARE PULLED CLEAR FROM THE LADDER.** (See Fig. 14.1)

2. Repeat this step for each corner of the Lift.

Fig 14.1

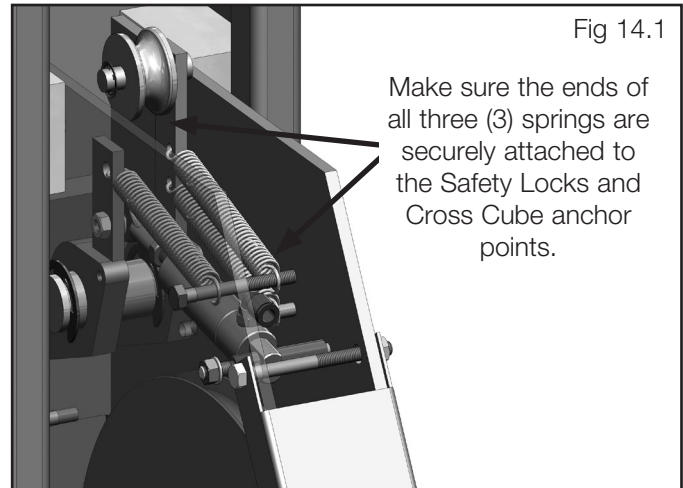

Make sure the ends of all three (3) springs are securely attached to the Safety Locks and Cross Cube anchor points.

STEP 15

(Lift Start Up / Final Adjustments)

1. Make sure the Power Unit reservoir is full with 12 quarts of 10-WT hydraulic oil or Dexron-III automatic transmission fluid.

2. Spray the inside of the Columns where the Slide Blocks glide with a light lubricant or WD-40.

3. Test the Power Unit by pressing the push-button switch. If the motor sounds like it is operating properly, raise the Lift and check all Hose Connections for leaks. If the motor gets hot or sounds peculiar, stop and check all electrical connections.

4. Before proceeding, double-check to make sure all Cables are properly positioned within the grooves of ALL Sheaves. Make sure all Cable Sheave retaining pins and/or clips are secure.

5. Check to make sure that all Slack Safety Locks are cleared and free. (See Fig. 15.1)

6. Continue pressing the raise button until the Cables get taugth and the Lift starts to move.

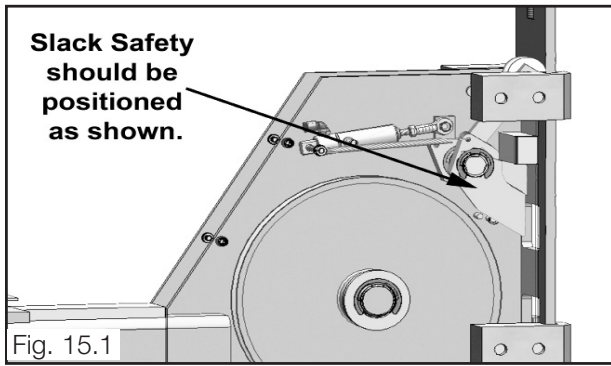

7. Raise Lift until the Lift stops and lower until the Safeties engage the Top Locking Position. Adjust each ladder so that each Safety Lock rests on the corresponding Top Lock Position. Then adjust each Cable Nut so that each Safety Lock is ONE INCH (1") above the Top Lock Position. The Cable Nuts **MUST** be tightened until there is at least one inch of threads protruding through the nut. (See Fig. 15.2) Failure to do so could result in serious injury or death.

All Cable Nuts **MUST be tightened on each end until there is at least one inch of thread protruding through the nut. Failure to do so could result in serious injury or death.**

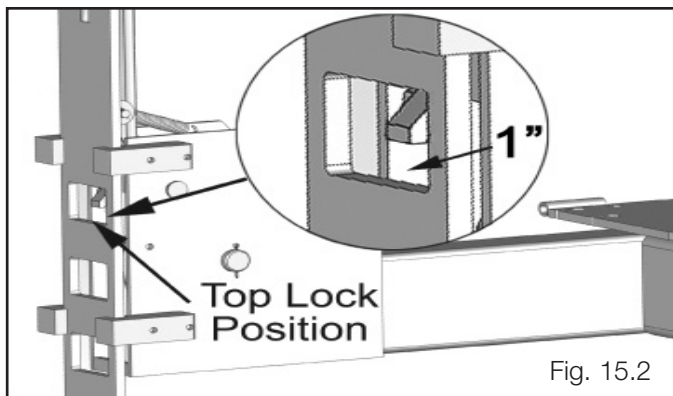

⚠ WARNING

NOTE:

There will be initial stretching of the cables in the beginning and/or with increased loads. Adjust the cables as outlined above a week after first use, then every three to six months thereafter depending on usage and/or to compensate for stretch.

8. After connecting the air supply, press the PUSH BUTTON AIR VALVE and check that all safety locks are functioning properly. Lower the Lift by pressing the push button air valve and power unit lowering valve simultaneously.

⚠ WARNING

KEEP HANDS AND FEET CLEAR. Remove hands and feet from any moving parts. Keep feet clear of Lift when lowering. Avoid pinch points.

9. Check all MAIN SAFETY LOCKS to make sure they move freely and spring back to the lock position when released. Lubricate all SAFETY PIVOT points with WD-40 or equal.

10. Run the Lift up and down a few times to ensure that the locks are engaging uniformly and that the safety release mechanisms are functioning. Re-adjust if necessary.

STEP 16

(Attaching Approach Ramps/ Tire Stops)

1. Install the approach ramps on the entry side of the Lift.
2. For HDSO-14AX use Lower Pin Tube. (See Fig. 16.1)
3. Adjust the angle of the raised Approach Ramps using

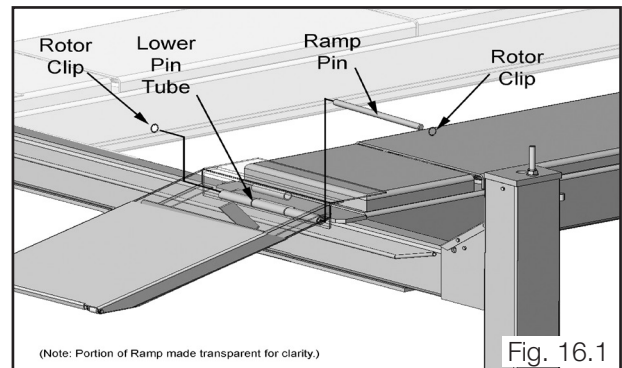

the Bolt and the Locking Nuts on the under side of the Ramps. (See Fig. 16.2)

4. Install the Front Tire Stops at the open side of the Lift

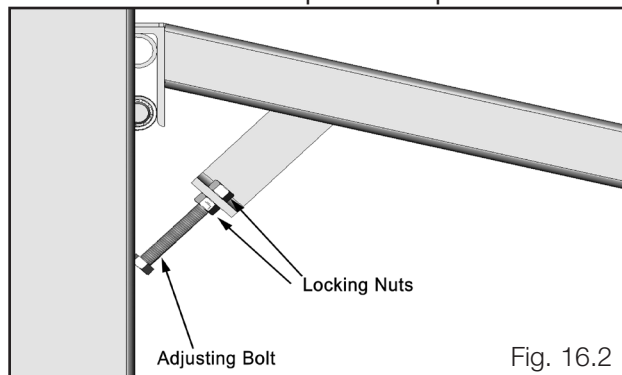

using the M14 x 2 Hex Bolts, Nuts and Washers. (See fig. 16.3)

5. Place the Turnplates in the Turnplate pockets. Insert the Rollback Spacer Bars between the Turnplate and risers as needed for alignment procedures. (See Fig 16.4)

6. Install the four Cross tube Covers. (See Fig. 16.5)

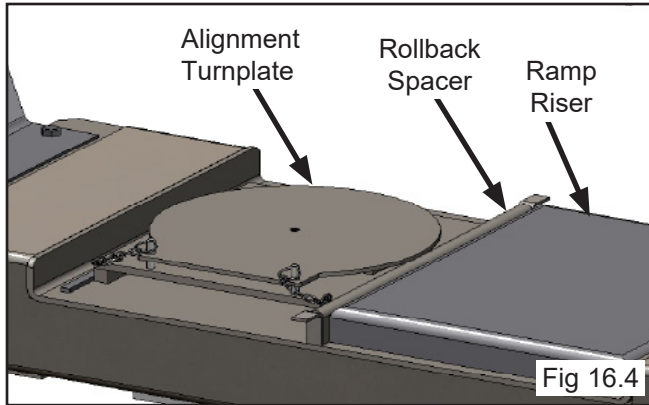
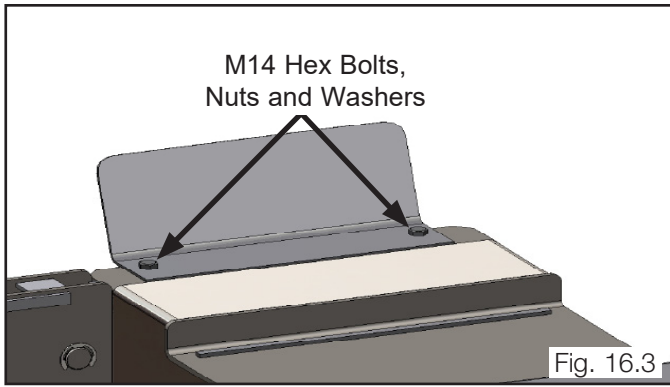

STEP 17

(Leveling / Synchronizing)

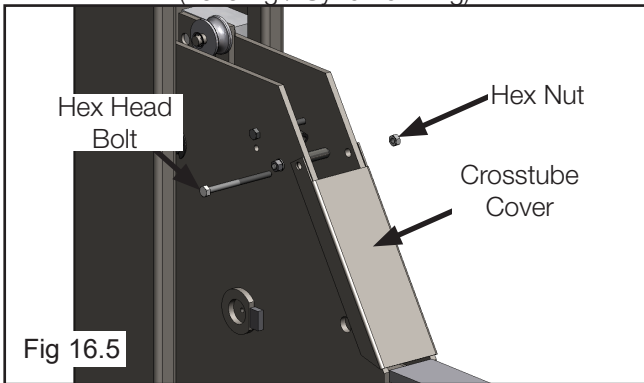

1. Using an engineer's automatic Level (transit), locate the Level, at a convenient location in the shop that allows an unobstructed view of all four corners of the runways.
2. Follow the Level manufacturer's instructions for proper setup of the Level. Be sure it is adjusted level in all directions.
3. Raise the Lift approximately 30" to 40". Then lower the Lift until all primary safeties are engaged in each column and the runways are completely resting on the primary safeties.
4. Place a Level target on the right/front corner of the runway. (See Fig. 17.1)
5. Beginning with "A" position, sight the level to the target and mark the number or the graduation on the inch scale of the target that aligns to the cross hairs of the Level, (See Fig. 17.1)

NOTE:

Use a pencil, marking pen or attach a paper clip

onto the target scale at the crosshair reference.

6. Next, move the target and place it at point "B" on the

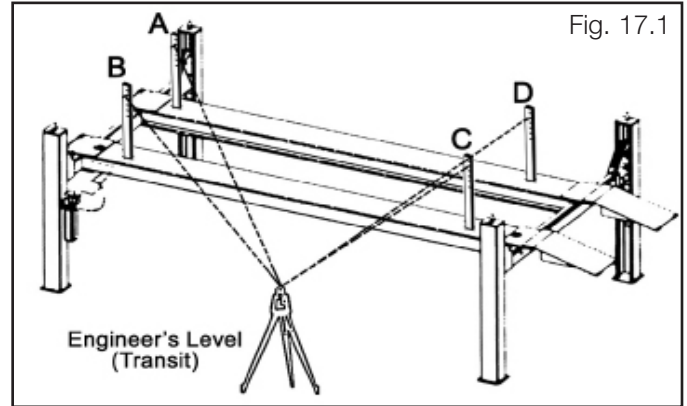

runway. (See Fig. 17.1)

7. Rotate the Level and focus on the target scale.
8. Adjust the adjustment nut on the safety ladder bar at the top of the column at "B" until the crosshairs of the Level align to reference mark on the target scale. (See Fig. 17.1)
9. Repeat steps locating the target assembly at points "C" and "D" and adjusting safety ladders at each corresponding column until the reference mark on the target scale is on the crosshairs of the Level. The runways are now level at all four points. (See Fig. 17.1)
10. To complete the leveling procedures, lock each safety ladder jam nut tightly against bottom of column top plate. (See Fig. 17.2.)

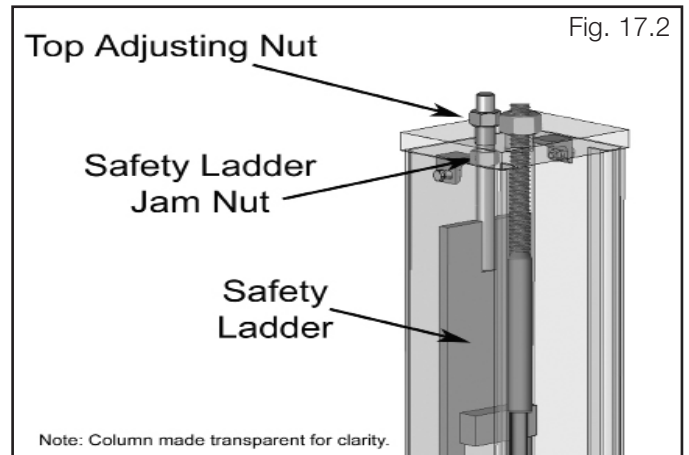

11. Next, load Vehicle onto the Lift.
12. Raise the Lift to full height. Listen and watch as the primary safeties engage the safety ladder. Synchronize by adjusting the cables so that all four latches click at same time. Make necessary adjustments to the cables allowing compensation for stretch.

13. Remove the Vehicle from the Lift and using a level adjust both the Left and Right Short Crosstube until just a slight upward angle is produced. This upward angle will be corrected with Vehicle loading. A 14mm Hex Socket is required to adjust the cap screw illustrated below Fig. 17.3.

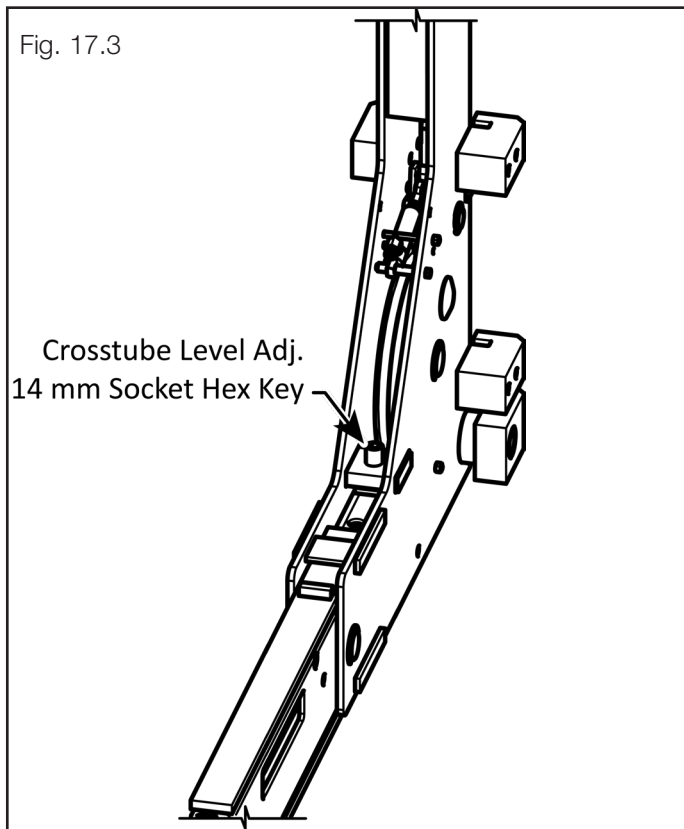

Safety locks may not engage at exactly the same time when Vehicles are being raised. They should be close. Be sure that all four corners have passed the SAME safety ladder bar slot before lowering Lift on the safety locks. NEVER lower Lift on different safety lock position or damage to the Lift may result.

STEP 18

(Bleeding)

1. Lift must be fully lowered before changing or adding fluid.
2. Raise and lower the Lift six times. The Cylinder is self-bleeding. After bleeding the system, fluid level in power unit reservoir may be reduced. Add more fluid if necessary to raise the Lift to its full height.
3. To pressure test, run Lift to full rise and run Motor for approximately 3-seconds after the Lift stops. This will place pressure on the hydraulic system. Stop and check all fittings and hose connections. Tighten or reseal if required.

STEP 19

(APPLY ANTI-SLIP TAPE)

1. Clean the runway. Use a broom or brush to remove loose dirt and debris from the runway.
2. Thoroughly wash, rinse and dry the runway using a mild solution of soap and clean water to remove any oils, grease and water-soluble contamination. Dry the runway with a clean cloth and allow to air dry.
3. Cut the Anti-Slip Tape into four equal pieces. Suggested length is 72 in. (1,829 mm).
4. Verify the Runway is dry and clean. It is critical for maximum adhesion of the Anti-Slip Tape that the runway be dry, free of dirt, oils and grease.
5. Measure and mark the runways with pencil guide lines to outline the tape installation area on the ramp. Refer to the figure on the next page for a suggested layout of the Anti-Slip Tape.

IMPORTANT! Do not install this Tape directly on the edge of a Runway. Stay at least 1 in (25 mm) away from edges. Do not attempt to bend this Tape over an edge.

6. Wash your hands. The Anti-Slip Tape's adhesive side is protected by a paper or plastic film. You will remove this film a few inches at a time to apply the Tape to the Runway.

IMPORTANT! Handle the tape by its edges. Minimize contact between the adhesive and your hands. The oils from your hands will reduce the adhesive's long-term effectiveness.

IMPORTANT! BendPak recommends two people work together to install the Tape. One person removes the backing and applies the Tape to the Runway while the second holds the Tape in place over the guide lines marked on the Runway.

7. Lay one piece of the Anti-Slip Tape on the runway and peel back about 2 inches (50 mm) of the protective film. Apply the adhesive side to the Runway inside the guide lines you created in step 5.

8. Slowly remove the film as you press the exposed Tape's adhesive side into the Runway. Work slowly and apply 2 to 5 inches at a time to stay within your guide lines.

9. After applying the Tape use a heavy rubber roller to press the Tape into the Runway and to ensure firm contact with the adhesive.

10. Apply the Anti-Slip Tape to the remaining area of the Lift's runways similar to the figure below.

Fig. 19.1

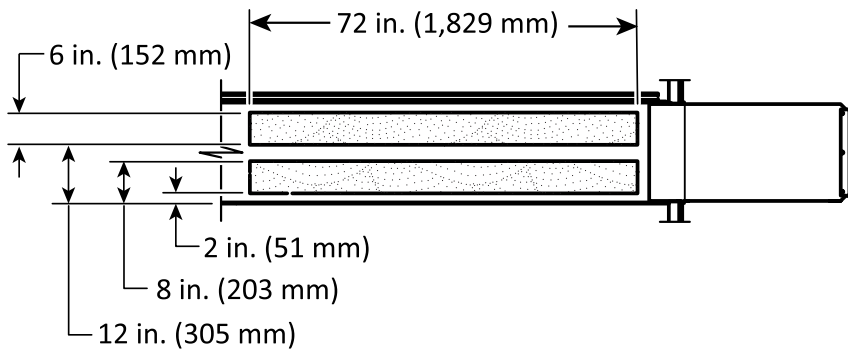
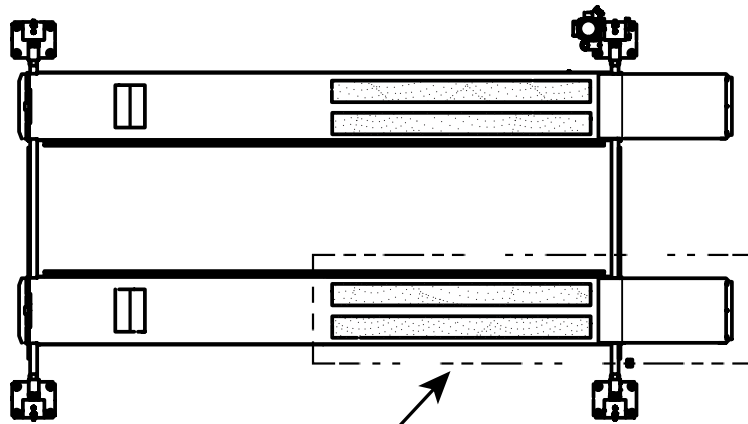
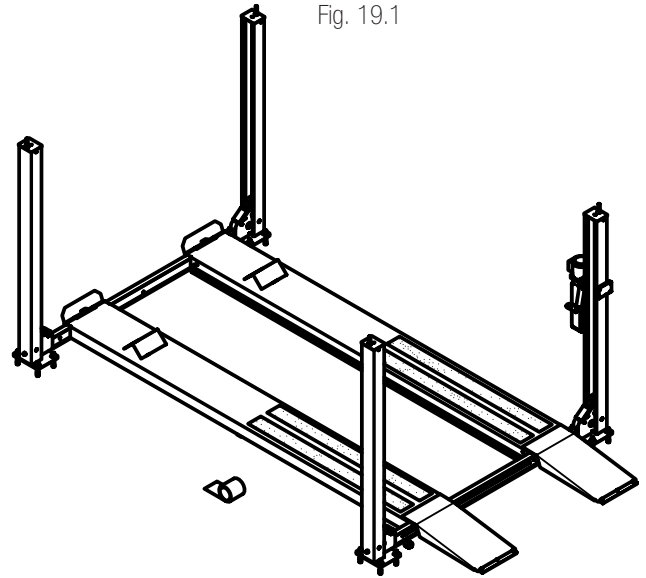

POST-INSTALLATION CHECK-OFF

- Columns properly shimmed and stable
- Anchor Bolts tightened
- Pivot / Sheave Pins properly attached
- Electric power supply confirmed
- Cables adjusted properly
- Safety Locks functioning properly
- Check for hydraulic leaks
- Oil level
- Lubrication of critical components
- Check for overhead obstructions
- All Screws, Bolts, and Pins securely fastened
- Surrounding area clean
- Operation, Maintenance and Safety Manuals on site.
- Perform an Operational Test with a typical Vehicle



Wheels Chock must be used on the rear wheels. (See Fig 18.1)

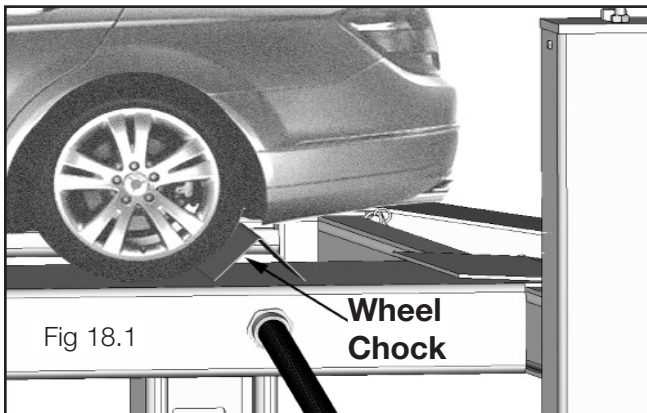

To reduce the risk of property damage, personal injury, or loss of life, **NEVER park any vehicle on the Lift's runways without placing two suitable wheel chocks behind each rear tire** so that the vehicle cannot roll backward off the Lift. Vehicles parked on Lift **MUST** also be placed in Park or First Gear (Manual Transmission) with the Parking Brake fully applied.

OPTIONAL EQUIPMENT INSTALLATION

Rolling Jack maximum weight capacity for use with HDSO-14P or HDSO-14AX is 7,000 lb (3,175 kg) per unit.

HDS/HDSO-14LSX Rolling Jack Air Line Kit Installation Part # 5174009

REV 03/21/2012

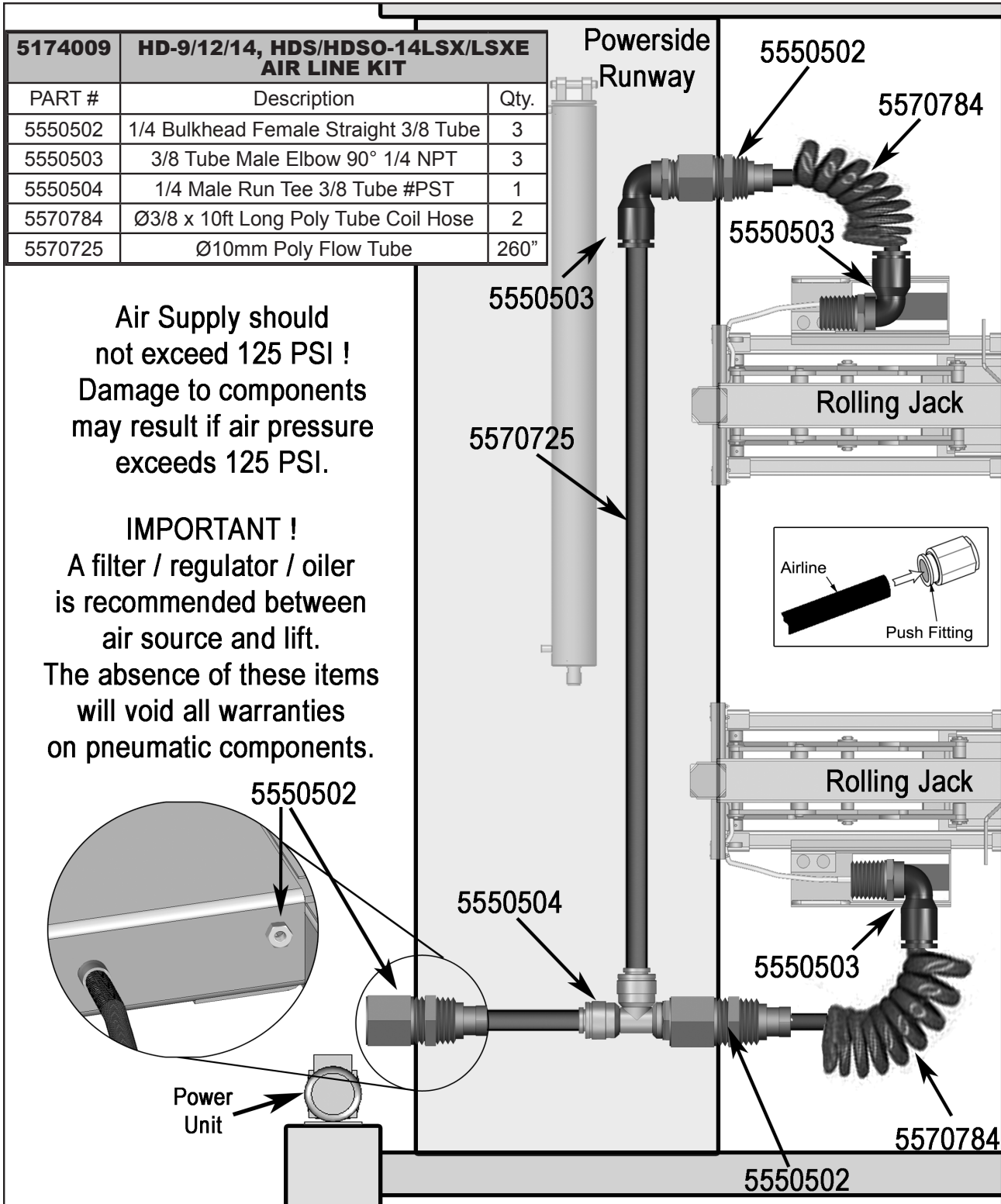

Operate and
Store
Rolling Jacks
Only
Within the
Safe Range
Reccomended
By The
Lift
Manufacturer

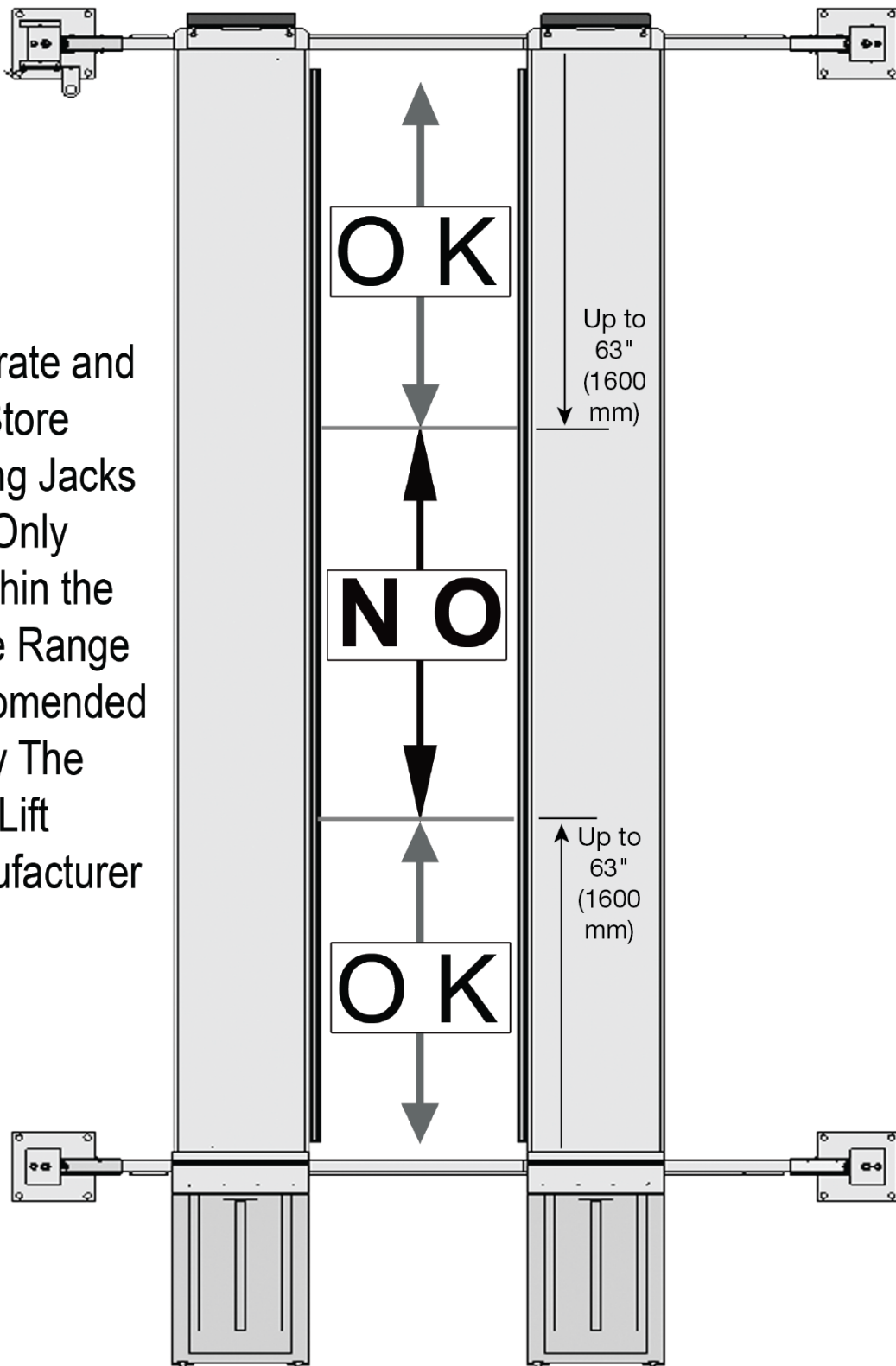

STEP 19

(Operation Instructions)

OWNER/EMPLOYER RESPONSIBILITIES

The Owner/Employer:

- Shall ensure that Lift operators are qualified and that they are trained in the safe use and operation of the Lift using the manufacturer's operating instructions; ALI/SM01-1, ALI Lifting It Right safety manual; ALI/ST-90 ALI Safety Tips card; ANSI/ALI ALOIM-(current edition), American National Standard for Automotive Lifts-Safety Requirements for Operation, Inspection and Maintenance; ALI/WL Series, ALI Uniform Warning Label Decals/Placards; and in the case of frame engaging Lifts, ALI/LP-GUIDE, Vehicle Lifting Points/Quick Reference Guide for Frame Engaging Lifts.
- Shall establish procedures to periodically inspect the Lift in accordance with the Lift manufacturer's instructions or ANSI/ALI ALOIM-(current edition), American National Standard for Automotive Lifts-Safety Requirements for Operation, Inspection and Maintenance; and The Employer shall ensure that Lift inspectors are qualified and that they are adequately trained in the inspection of the Lift.
- Shall establish procedures to periodically maintain the Lift in accordance with the Lift manufacturer's instructions or ANSI/ALI ALOIM-(current edition), American National Standard for Automotive Lifts-Safety Requirements for Operation, Inspection and Maintenance; and The Employer shall ensure that Lift maintenance personnel are qualified and that they are adequately trained in the maintenance of the Lift.
- Shall maintain the periodic inspection and maintenance records recommended by the manufacturer or ANSI/ALI ALOIM-(current edition), American National Standard for Automotive Lifts-Safety Requirements for Operation,

STEP 20

(Lift Operation Safety)



TO AVOID PERSONAL INJURY AND/OR PROPERTY DAMAGE, PERMIT ONLY TRAINED PERSONNEL TO OPERATE Lift. AFTER REVIEWING THESE INSTRUCTIONS, PRACTICE USING Lift CONTROLS BY RUNNING THE Lift THROUGH A FEW UNLOADED CYCLES BEFORE LOADING Vehicle ON Lift. **NEVER** RAISE JUST ONE END, ONE CORNER, OR ONE SIDE OF Vehicle.

Inspection and Maintenance.

- Shall display the Lift manufacturer's operating instructions; ALI/SM 93-1, ALI Lifting It Right safety manual; ALI/ST-90 ALI Safety Tips card; ANSI/ALI ALOIM-(current edition), American National Standard for Automotive Lifts-Safety Requirements for Operation, Inspection and Maintenance; and in the case of frame engaging Lifts, ALI/LP-GUIDE, Vehicle Lifting Points/Quick Reference Guide for Frame Engaging Lifts; in a conspicuous location in the Lift area convenient to the operator.
- Shall provide necessary lockout/tagout means for energy sources per ANSI Z244.1-(current edition), Safety Requirements for the Lockout/Tagout of Energy Sources, before beginning any Lift repairs.
- Shall not modify the Lift in any manner without the prior written consent of the manufacturer.



- **DAILY** inspect your Lift. Never operate if it malfunctions or if it has broken or damaged parts. Use only qualified Lift service personnel and genuine BendPak parts to make repairs.
- **THOROUGHLY** train all employees in use and care of Lift, using manufacturer's instructions and "Lifting It Right" and "Safety Tips" supplied with the Lift.
- **NEVER** allow unauthorized or untrained persons to position Vehicle or operate Lift.
- **PROHIBIT** unauthorized persons from being in shop area while Lift is in use.
- **DO NOT** permit anyone on Lift or inside Vehicle when it is either being raised or lowered.

Lift OPERATION SAFETY (CONT'D)

- **ALWAYS** keep area around Lift free of tools, debris, grease and oil.
- **NEVER** overload Lift. Capacity of Lift is shown on nameplate affixed to the Lift.
- **DO NOT** stand in front of the Vehicle while it is being positioned in Lift bay.
- **DO NOT** block open or override self-closing Lift controls; they are designed to return to the "Off" or Neutral position when released.
- **ALWAYS** remain clear of Lift when raising or lowering Vehicles.
- **ALWAYS** use safety stands when removing or installing heavy components.
- **DO NOT** go under raised Vehicle if safety locks are not engaged.
- **NEVER LEAVE Lift IN ELEVATED CONDITION** unless all Safety Locks are engaged.
- **AVOID** excessive rocking of Vehicle while on Lift.
- **ALWAYS CLEAR AREA** if Vehicle is in danger of falling.
- **ALWAYS REMOVE** tool trays, stands, etc. before lowering Lift.
- **ALWAYS RELEASE** safety locks before attempting to lower Lift.
- **DO NOT** position yourself between a wall and the Lift. If the Vehicle falls in that direction, you may be severely injured or killed.

CAUTION! Lift is slippery when wet or icy!
CAUTION! Always use Wheel Chocks!

To Raise Lift;

1. Position Vehicle tires in the center of each Runway.
2. Set parking brake and use Wheel Chocks to hold Vehicle in position.
3. Before raising Vehicle, be sure all personnel are clear of the Lift and surrounding area. Pay careful attention to overhead clearances.

NOTE:

ALLOW (2) SECONDS BETWEEN MOTOR STARTS.
FAILURE TO COMPLY MAY CAUSE MOTOR BURNOUT.

4. Raise the Lift to the desired height by pressing the push button on the power unit.
5. After Vehicle is raised to the desired height, lower the Lift onto the nearest Safety Lock. Do not allow Cables to become slack. **ALWAYS ENSURE ALL SAFETY LOCKS ARE ENGAGED** before entering work area.



VISUALLY CONFIRM THAT ALL PRIMARY SAFETY LOCKS ARE ENGAGED BEFORE ENTERING WORK AREA. SUSPENSION COMPONENTS USED ON THIS Lift ARE INTENDED TO RAISE AND LOWER Lift ONLY AND ARE NOT MEANT TO BE LOAD HOLDING DEVICES. REMAIN CLEAR OF ELEVATED Lift UNLESS VISUAL CONFIRMATION IS MADE THAT ALL PRIMARY SAFETY LOCKS ARE FULLY ENGAGED AND THE Lift IS LOWERED ONTO THE SAFETY LOCKS, REFER TO INSTALLATION/OPERATION MANUAL FOR PROPER SAFETY LOCK PROCEDURES AND/OR FURTHER INSTRUCTION.

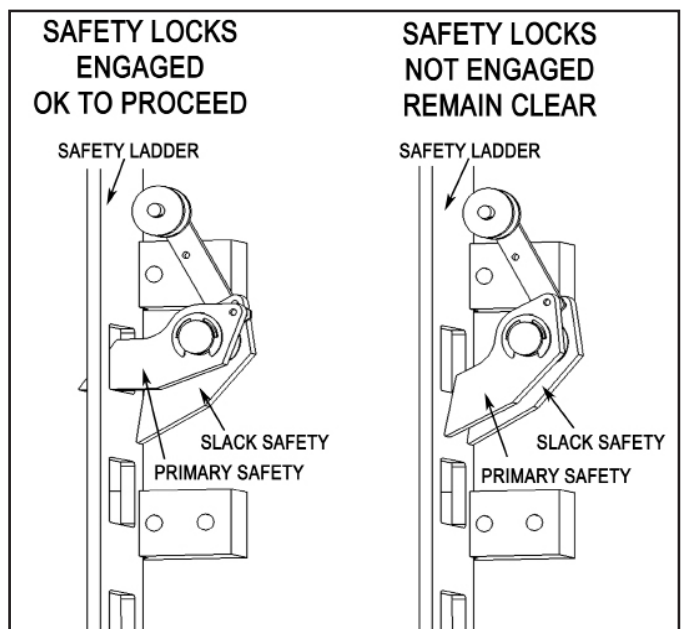

WHEN LOWERING THE Lift PAY CAREFUL ATTENTION THAT ALL PERSONNEL AND OBJECTS ARE KEPT CLEAR. ALWAYS KEEP A VISUAL LINE OF SIGHT ON THE LIFT AT ALL TIMES. ALWAYS MAKE SURE THAT ALL LOCKS ARE DISENGAGED. IF ONE OF THE LOCKS INADVERTENTLY LOCKS UPON DESCENT THE Vehicle MAY DISMOUNT CAUSING PERSONAL INJURY OR DEATH.

To Lower Lift;

1. Before lowering Vehicle, be sure all personnel are clear of the Lift and surrounding area. Pay careful attention to overhead clearances. Ensure all tools and equipment have been cleared from under the Lift.

Lift OPERATION SAFETY (CONT'D)

2. Raise the Lift off of the Safety Locks by pressing the push button on the Power Unit. Make sure you raise the Lift by at least two inches to allow adequate clearance for the locks to clear.
3. Press the push button air safety valve and HOLD.
4. Push the LOWERING HANDLE on the Power Unit until the Lift has descended completely.



IF YOU ARE NOT COMPLETELY FAMILIAR WITH AUTOMOTIVE LIFT MAINTENANCE PROCEDURES; STOP AND CONTACT THE MANUFACTURER FOR INSTRUCTIONS. UNLESS STATED OTHERWISE, ALL MAINTENANCE CAN BE PERFORMED BY THE OWNER/EMPLOYER AND DOES NOT REQUIRE TRAINED Lift SERVICE PERSONNEL.

BEFORE PERFORMING MAINTENANCE ON YOUR LIFT, MAKE SURE IT IS COMPLETELY DISCONNECTED FROM POWER. IF YOUR ORGANIZATION HAS LOCKOUT/TAGOUT POLICIES, IMPLEMENT THOSE PROCEDURES AFTER CONNECTING TO THE POWER SOURCE.

DAILY MAINTENANCE

1. Make a visual inspection of ALL MOVING PARTS and check for excessive signs of wear.
2. Check safety locks to ensure they are in good operating condition.
3. Check cables and sheaves for wear. Replace worn parts as required with genuine BendPak parts.
4. Inspect adapters for damage or excessive wear. Replace as required with genuine BendPak parts.
5. Remove Slip Plates and inspect Ball Casters for Water, Salt or Dirt and brush clean, then dry. Apply WD-40 or equal to Ball Casters, if exposed to excess humidity, water or ice.

WEEKLY MAINTENANCE

1. Lubricate all Sheave pins and rollers with general purpose oil. (See page 42)
2. Check all Cable connections, bolts, and pins to ensure proper mounting.
3. Lubricate Safety Lock pivot points with white lithium grease.

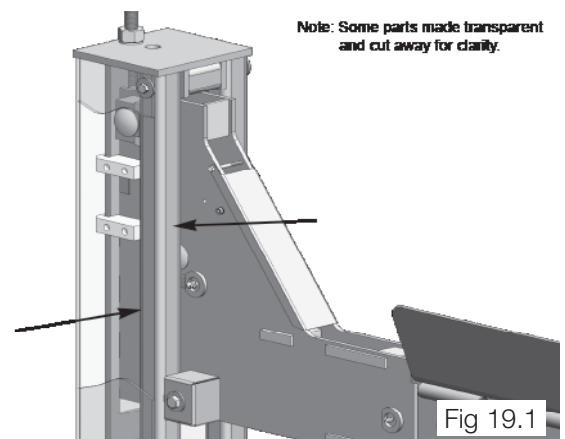

MONTHLY MAINTENANCE

1. Check Safety Locks to ensure they are in good operating condition. Lubricate locking latch shafts. Push release arm several times for oil to penetrate pivot points.
2. Check equalizer cable tension. Adjust per Lift installation instructions.
3. Check all Cables for excessive signs of wear.
4. Make a visual inspection of ALL MOVING PARTS and check for excessive signs of wear.
5. Lubricate both Open Front Post surfaces, on both sides, with white lithium grease. (See Fig 19.1)

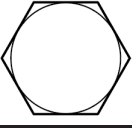
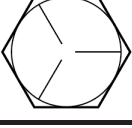

- Lubricate the slide blocks with white lithium grease. Heavy usage may require more frequent lubrication.
- Always call local service representative if electrical problems develop.
- Always replace ALL FAULTY PARTS before Lift is put back into operation.
- Every 3 Months: Check anchor bolt torque. Anchors should be torqued to 85 to 90 ft/lbs.
- Semi-Annually: Check fluid level of Lift power unit and refill if required per Lift installation instructions.
- Replace all caution, warning or safety related decals on the Lift if unable to read or missing. Reorder labels from BendPak.
- Refer to ANSI/ALI ALOIM booklet for periodic inspection checklist and maintenance log sheet.

TORQUE CHART

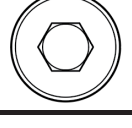
FASTENER TORQUE CHART													
Bolt Size (SAE)	Bolt Grade (SAE)	SAE Grade 0-1-2		SAE Grade 5		SAE Grade 8		Socket Head Cap Screw SAE Grade		Tightening Torque			
										Tightening Torque			
Bolt Size (SAE)	Bolt Class (Metric)	SAE Grade 0-1-2		SAE Grade 5		SAE Grade 8		Metric Class 12.9		Tightening Torque			
		Metric Class 4.6		Metric Class 8.8		Metric Class 10.9		Metric Class 12.9		Tightening Torque			
		Lubricated (ft-lbs)	Zinc Plated (ft-lbs)	Plain & Dry (ft-lbs)	Lubricated (ft-lbs)	Zinc Plated (ft-lbs)	Plain & Dry (ft-lbs)	Lubricated (ft-lbs)	Zinc Plated (ft-lbs)	Plain & Dry (ft-lbs)	Lubricated (ft-lbs)	Zinc Plated (ft-lbs)	Plain & Dry (ft-lbs)
1/4-20	M6 x1.0	2.3	2.6	3.0	5.8	6.6	7.7	8.3	9.4	11.1	9.7	11.0	13.0
5/16-18	M8 x 1.25	3.8	4.3	5.0	9.7	11.0	13.0	13.9	15.8	18.5	16.3	18.4	21.7
3/8-16	M10 x 1.50	10.8	12.3	14.4	27.9	31.6	37.2	39.9	45.2	53.2	46.7	52.9	62.2
7/16-14	N/A	24.0	27	30.0	35.0	42	50.0	55.0	59	70.0	61.0	68	76.0
1/2-13	M12 x 1.75	18.9	21.4	25.2	48.7	55.1	64.9	69.6	78.9	92.8	81.4	92.2	108.5
9/16-12	M14 x 2.00	30.2	34.2	40.2	77.8	88.1	103.7	111.3	126.1	148.4	130.0	147.4	173.4
5/8-11	M16 x 2.00	47	53	62	121	137	161	173	196	230	202	229	269
3/4-10	M18 x 2.50	65	73	86	167	189	222	239	270	318	279	316	372
7/8-9	M22 x 2.50	136	155	182	320	365	430	460	515	600	510	575	640

WARNING! Prior to installation, inspect all accompanying manuals, parts lists and catalogs to ensure you have all the necessary parts. Identify all fasteners and their proper torque settings as illustrated on this chart. Proper torquing practices cannot be over emphasized. Torque values are provided as a convenient method of achieving correct pre-loading of highly stressed fasteners. If the fasteners are not properly plated, the fastener threads are not clean and free of deformation, or are not properly lubricated, the correct fastener pre-load will not be achieved even though the given torque value is reached. For this reason, it is critical that all fasteners be inspected for proper plating, thread form and correctly lubricated prior to torquing. Failure to verify a fastener's serviceability or to correctly lubricate the fastener prior to assembly and torquing will result in the fastener not being properly pre-loaded and subsequent failure of the fastener may occur. The torque values can only be achieved if the nut (or tapped hole) has a proof load greater than or equal to the bolt's minimum ultimate tensile strength. Clamp loads estimated as 75% of proof load for specified bolts. Torque values are listed in foot-pounds. Torque wrenches should be calibrated on an annual basis. Never use an impact driver on a torque multiplier.

⚠ WARNING

WIRE ROPE INSPECTION AND MAINTENANCE

- ◆ Lifting cables should be replaced every three - five years or when visible signs of damage are apparent. **DO NOT USE Lift WITH DEFECTIVE / WORN CABLES.**
- ◆ Lifting cables should be maintained in a well-lubricated condition at all times. Wire rope is only fully protected when each wire strand is lubricated both internal and external. Excessive wear will shorten the life of the wire rope. The factory suggested wire rope lubricant that penetrates to the core of the rope and provides long-term lubrication between each individual strand is 90-WT gear oil or ALMASOL® Wire Rope Lubricant. In order to make sure that the inner layers of the rope remain well lubricated, lubrication should be carried out at intervals not exceeding three months during operation.
- ◆ All sheaves and guide rollers in contact with the moving rope should be given regular visual checks for surface wear and lubricated to make sure that they run freely. This operation should be carried out at appropriate intervals generally not exceeding three months during operation. For all sheave axles, the factory recommends standard wheel bearing grease. For all sheaves and/or guide rollers, the factory recommends 90-WT gear oil or similar heavy lubricant applied by any method including pump / spray dispensing, brush, hand and/or swabbing.

HOW OFTEN TO INSPECT

- ◆ Lifting cables should be visually inspected at least once each day when in use, as suggested by American Petroleum Institute (API) RP54 guidelines.
- ◆ Any Lifting cables that have met the criteria for removal must be immediately replaced.

WHEN TO REPLACE LIFTING CABLES DUE TO BROKEN WIRES

- ◆ Lifting cables should be removed from service when you see six randomly distributed broken wires within any one lay length, or three broken wires in one strand within one lay length.

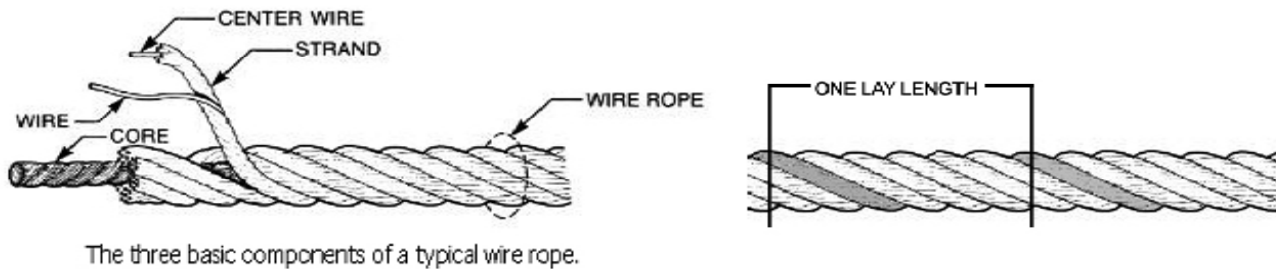

OTHER REASONS TO REPLACE LIFTING CABLES

- ◆ Corrosion that pits the wires and/or connectors.
- ◆ Evidence of kinking, crushing, cutting, bird-caging or a popped core.
- ◆ Wear that exceeds 10% of a wire's original diameter.
- ◆ Evidence of heat damage.

HOW TO FIND BROKEN WIRES

- ◆ The first step is to relax the rope to a stationary position and move the pick-up points off the sheaves. Clean the surface of the rope with a cloth — a wire brush, if necessary — so you can see any breaks.
- ◆ Flex the rope to expose any broken wires hidden in the valleys between the strands.
- ◆ Visually check for any broken wires. One way to check for crown breaks is to run a cloth along the rope to check for possible snags.
- ◆ With an awl, probe between wires and strands and Lift any wires that appear loose. Evidence of internal broken wires may require a more extensive rope examination.

Safe Lift Operation

Automotive and truck Lifts are critical to the operation and profitability of your business. The safe use of this and other Lifts in your shop is critical in preventing employee injuries and damage to customer's Vehicles. By operating Lifts safely you can ensure that your shop is profitable, productive and safe.

Safe operation of Automotive Lifts requires that only trained employees should be allowed to use the Lift.

TRAINING SHOULD INCLUDE, BUT BE NOT LIMITED TO:

- ◆ Proper positioning of the Vehicle on the runway. (See minimum/maximum wheel base loading requirements.)
- ◆ Use of the operating controls.
- ◆ Understanding the Lift capacity.
- ◆ Proper use of jack stands or other load supporting devices.
- ◆ Proper use, understanding and visual identification of safety lock devices and their operation.
- ◆ Reviewing the safety rules.
- ◆ Proper housekeeping procedures, (Lift area should be free of grease, oil, tools, equipment, trash, and other debris)
- ◆ A daily inspection of the Lift should be completed prior to its use. Safety devices, operating controls, Lift Arms and other critical parts should be inspected prior to using the Lift.
- ◆ All maintenance and repairs of the Lift should be completed by following the manufacturer's requirements. Lift repair parts should meet or exceed OEM specifications. Repairs should only be completed by a qualified Lift technician.
- ◆ The Vehicle manufacturer's recommendations should be used for spotting and Lifting the Vehicle.

LIFT OPERATION SAFETY

- ◆ It is important that you know the load limit. Be careful that you do not overload the Lift. If you are unsure what the load limit is, check the data plate found on one of the Lift Columns or contact the manufacturer.
- ◆ The center of gravity should be followed closely to what the manufacturer recommends.
- ◆ Always make sure you have proper overhead clearance. Additionally, check that attachments, (Vehicle signs, campers antennas, etc.) are not in the way.
- ◆ Be sure that prior to the Vehicle being raised, the doors, trunk, and hood are closed securely.
- ◆ Prior to being raised, make sure there is no one standing closer than six feet from the Lift.
- ◆ After positioning the Vehicle on the Lift runways, set the emergency brake, make sure the ignition is off, the doors are closed, overhead obstructions are cleared, and the transmission is in neutral.
- ◆ Double check that the wheel chocks are in position.
- ◆ Put pads or adapters in the right position under the contact points that have been recommended.
- ◆ The Lift should be raised just until the Vehicle's wheels are about one foot off the ground. If contact with the Vehicle is uneven or it appears that the Vehicle is not sitting secure, carefully lower the Lift and readjust.
- ◆ Always consider potential problems that might cause a Vehicle to slip, i.e., heavy cargo, undercoating, etc.
- ◆ Pay attention when walking under a Vehicle that is up on the Hydraulic Lift.



- ◆ **DO NOT** leave the controls while the Lift is still in motion.
- ◆ **DO NOT** stand directly in front of the Vehicle or in the bay when Vehicle is being loaded or driven into position.
- ◆ **REMAIN CLEAR** of the Lift when raising or lowering Vehicle.
- ◆ **DO NOT** rock the Vehicle while on the Lift or remove any heavy component from Vehicle that may cause excessive weight shift.
- ◆ **DO NOT** lower the Vehicle until people, materials, and tools are clear
- ◆ **ALWAYS ENSURE** that the safeties are engaged and lowered on to the safety ladders before any attempt is made to work on or near Vehicle.
- ◆ Some Vehicle maintenance and repair activities may cause the Vehicle to shift. Follow the manufacturer's guidelines when performing these operations. The use of jack stands or alternate Lift points may be required when completing some repairs.
- ◆ **READ AND UNDERSTAND** all safety warning procedures before operating Lift.
- ◆ **KEEP HANDS AND FEET CLEAR.** Remove hands and feet from any moving parts. Keep feet clear of Lift when lowering. Avoid pinch points.
- ◆ **ONLY TRAINED OPERATORS** should operate this Lift. All non-trained personnel should be kept away from work area. Never let untrained personnel come in contact with, or operate Lift.
- ◆ **USE LIFT CORRECTLY.** Use Lift in the proper manner. Never use Lifting Adapters other than what is approved by the manufacturer.
- ◆ **DO NOT** override self-closing Lift controls.
- ◆ **CLEAR AREA** if Vehicle is on danger of falling.
- ◆ **STAY ALERT.** Watch what you are doing. Use common sense. Be aware.
- ◆ **CHECK FOR DAMAGED PARTS.** Check for alignment of moving parts, breakage of parts or any condition that may affect its operation. Do not use Lift if any component is broken or damaged.
- ◆ **NEVER** remove safety related components from the Lift. Do not use Lift if safety related components are damaged or missing.
- ◆ When the Lift is being lowered, make sure everyone is standing at least six feet away.
- ◆ Be sure there are no jacks, tools, equipment, left under the Lift before lowering.
- ◆ Always lower the Vehicle down slowly and smoothly.



If your Lift is not functioning correctly, you **must** take it out of service until it is fixed. All repair work must be performed by qualified personnel. If your organization has Lockout/Tagout policies, implement them after connecting the Lift to the power source.

Lift WILL NOT RAISE

POSSIBLE CAUSE

1. Air in oil, (1,2,8,13)
2. Cylinder binding, (9)
3. Cylinder leaks internally, (9)
4. Motor run backward under pressure, (11)
5. Lowering valve leaks, (3,4,6,10,11)
6. Motor runs backwards, (7,14,11)
7. Pump damaged, (10,11)
8. Pump won't prime, (1,8,13,14,3,12,10,11)
9. Relief valve leaks, (10,11)
10. Voltage to motor incorrect, (7,14,11)

REMEDY

1. Check for proper oil level.
2. Bleed cylinders.
3. Flush- Release valve to get rid of. possible contamination
4. Dirty oil.
5. Tighten all fasteners.
6. Check for free movement of release.
7. Check motor is wired correctly.
8. Oil seal damaged or cocked
9. See Installation Manual
10. Replace with new part
11. Return unit for repair
12. Check pump-mounting bolts
13. Inlet screen clogged
14. Check wall outlet voltages and wiring

INSTRUCTION

1. The oil level should be up to the bleed screw in the reservoir with the Lift all the way down.
2. See Installation Manual.
3. Hold release handle down and start unit allowing it to run for 15 seconds.
4. Replace oil with clean Dexron ATF.
5. Tighten fasteners to recommended torques.
6. If handle does not move freely, replace bracket or handle assembly.
7. Compare wiring of motor to electrical diagram on drawing.
8. Replace oil seal around pump shaft.
9. Consult Lift Manufacturer.
10. Replace with new part.
11. Return unit for repair.
12. Bolts should be 15 to 18 ft. lbs.
13. Clean inlet screen or replace.
14. Make sure unit and wall outlet are wired properly.

MOTOR WILL NOT RUN

POSSIBLE CAUSE

1. Fuse blown, (5,2,1,3,4)
2. Limit switch burned out, (1,2,3,4)
3. Microswitch burned out, (1,2,3,4)
4. Motor burned out, (1,2,3,4,6)
5. Voltage to motor incorrect, (2,1,8)

REMEDY

1. Check for correct voltage
2. Check motor is wired correctly
3. Don't use extension cords
4. Replace with new part
5. Reset circuit breaker/fuse
6. Return unit for repair
7. See Installation Manual
8. Check wall outlet voltage and wiring

INSTRUCTION

- Compare supply voltage with voltage on motor nametag. Check that the wire is sized correctly. N.E.C. table 310-12 requires AWG 10 for 25 Amps.
- Compare wiring of motor to electrical diagram on drawing.
- According to N.E.C. : " The size of the conductors... should be such that the voltage drop would not exceed 3% to the farthest outlet for power..." Do not run motor at 115 VAC – damage to the motor will occur.
- Replace with new part.
- Reset circuit breaker/fuse.
- Return unit for repair.
- See Installation Manual.
- Make sure unit and wall outlet is wired properly. Motor must run at 208/230 VAC.

Lift LOWERS SLOWLY OR NOT AT ALL

POSSIBLE CAUSE

1. Cylinders binding, (1)
2. Release valve clogged, (5,4,2,3)
3. Pressure fitting too long, (6)

REMEDY

1. See Installation Manual
2. Replace with new part
3. Return for repair
4. Check oil.
5. Clean release valve
6. Replace fitting with short thread lead

INSTRUCTION

- Consult Lift Manufacturer.
- Replace with new part.
- Return for repair.
- Use clean 10-WT hydraulic oil or Dexron-III automatic transmission fluid only. If ATF is contaminated, replace with clean ATF and clean entire system.
- Wash release valve in solvent and blow out with air.
- Replace fitting with short thread lead.

WILL NOT RAISE LOADED Lift

POSSIBLE CAUSE

1. Air in oil, (1,2,3,4)
2. Cylinder binding, (5)
3. Cylinder leaks internally, (5)
4. Lift overloaded, (6,5)
5. Lowering valve leaks, (7,8,1,5,9)
6. Motor runs backwards, (10,12,9)
7. Pump damaged, (5,9)
8. Pump won't prime, (1,2,3,4,5,11,9)
9. Relief valve leaks, (8,5,9)
10. Voltage to motor incorrect, (10,12,5)

REMEDY

- | REMEDY | INSTRUCTION |
|--|--|
| 1. Check oil level | The oil level should be up to the bleed screw in the reservoir [with the Lift all the way down.] |
| 2. Check/Tighten inlet tubes | Replace inlet hose assembly. |
| 3. Oil seal damaged or cocked | Replace oil seal and install. |
| 4. Bleed cylinders | See Installation Manual. |
| 5. See Installation Manual | Consult Lift Manufacturer. |
| 6. Check Vehicle weight | Compare weight of Vehicle to weight limit of the Lift. |
| 7. Flush release valve | Hold release handle down and start unit allowing it to run for 15 seconds. |
| 8. Replace with new part | Replace with new part. |
| 9. Return unit for repair | Return unit for repair. |
| 10. Check motor is wired correctly | Compare wiring of motor to electrical diagram on power unit drawing. |
| 11. Inlet screen clogged | Clean inlet screen or replace. |
| 12. Check wall outlet voltage and wiring | Make sure unit and wall outlet is wired properly. |

IMPORTANT

If Vehicle becomes stranded in the air, follow all operation instructions as shown on pages 32, 33, 39 and 40. If after observing that all mechanical locks are released and the Lift still fails move following all standard operating procedures, immediately stop using the Lift and contact factory or factory approved service center for further instructions.

Lift WILL NOT STAY UP

POSSIBLE CAUSE

1. Air in oil, (1,2,3)
2. Check valve leaks, (6)
3. Cylinders leak internally, (7)
4. Lowering valve leaks, (4,5,1,7,6)
5. Leaking fittings, (8)

REMEDY

1. Check oil level The oil level should be up to the bleed screw in the reservoir with the Lift all the way down.
2. Oil seal damaged and cocked Replace oil seal around pump shaft.
3. Bleed cylinder Refer to Installation Manual.
4. Flush release valve Hold release handle down and start unit allowing it to run for 15 seconds.
5. Replace with new valve Replace with new valve.
6. Return unit for repair Return unit for repair.
7. See Installation Manual Consult Lift Manufacturer.
8. Check complete hydraulic system for leaks. Tighten all hydraulics fittings and inspect all hoses.

INSTRUCTION

MODEL HDSO-14P/AX Lift Disposal - End of Service Life

Once your Lift has reached the end of its service life it must be disposed of properly. Metal recyclers will be able to advise on methods and costs to remove the Lift and will reuse the materials, diverting them from landfills. The best option is to contact a metal recycling center and discuss the size and weight of the Lift to determine if the facility can deconstruct and recover the usable components and metals.

The Hydraulic Cylinders, Hoses, Fittings, and the Power Unit itself must be disposed of in accordance with current national, state, and local regulations governing the use and disposal of hazardous materials. These components and any used Hydraulic Fluid must not be disposed of by dropping it into the trash or dumping it into the street. The Hydraulic Fluid contains toxic ingredients that are harmful to the environment.

These components and the Hydraulic Fluid are required to be recycled or must be delivered to a hazardous waste collection facility.

If you have large amounts of Hydraulic Fluid, consider contacting a commercial waste disposal company. In all cases, the best approach is to find an appropriate facility and contact them — in advance — to ask them: what kinds of fluids and materials they accept, what kind of containers it must be in, what hours they are open, their location, and any other information specific to their facility.

If you are unable to find an appropriate facility, the website **earth911.com** has resources that may be of help.

Labels



PN 5905311

⚠ DANGER

VISUALLY CONFIRM THAT ALL PRIMARY SAFETY LOCKS ARE ENGAGED BEFORE ENTERING WORK AREA.

Suspension components on this lift are intended to raise and lower lifts; they are NOT load-bearing devices. Do not use under an extended lift until visual confirmation is made that the lift is engaged on its Safety Locks. Refer to the manual for proper Safety Lock procedures and additional instructions.

VÉRIFIER VISUELLEMENT QUE TOUS LES VERROUS DE SÉCURITÉ PRIMAIRES SONT ENGAGÉS AVANT D'ENTRER DANS LA ZONE DE TRAVAIL.

Les composants de suspension de cet élévateur sont destinés à élever et abaisser l'ascenseur; ce ne sont PAS des dispositifs de maintien de la charge. Ne passez pas sous un ascenseur prolongé avant d'avoir obtenu la confirmation visuelle que l'ascenseur est engagé sur ses verrous de sécurité. Reportez-vous au manuel pour connaître les procédures de verrouillage de sécurité et les instructions supplémentaires.

⚠ WARNING

Wire Rope Inspection and Maintenance

- Replace lifting cables if wear or damage is noticed, such as excessive broken strands, kinks, deformations, or areas of heavy abrasion.
- Keep wire ropes in a well-lubricated condition at all times. Wire rope is only fully protected when each wire strand is lubricated, both internally and externally. Excessive wear may occur if the wire rope is lubricated that penetrates to the core of the rope and provides long term lubrication between individual strands. Lubrication should be done at least every three months during normal operation.
- All gears and guide rollers in contact with the moving wire rope should be given regular visual checks for surface wear and lubricated to make sure they are free. This should be done at least every three months during normal operation. For drive rollers, use standard wheel bearing grease. For all others and/or guide rollers, use 90-WT gear oil or similar heavy lubricant applied by any method including pump/spray dispensing, brush, hand, and/or wetting.

Failure to read, understand, and follow these instructions may cause death or serious injury. Read and understand these instructions before using lift.

⚠ ATTENTION

Inspection et maintenance des câbles

- Remplacez les câbles de levage si l'usage ou des dommages sont évidents, tels que des brins cassés, des fentes, des déformations ou des zones de forte abrasion excessive.
- Gardez les câbles métalliques bien lubrifiés en tout temps. Le câble métallique n'est effectivement protégé que si chaque brin individuel est lubrifié à la fois de l'intérieur et à l'extérieur. Une usure excessive se produit si le câble est lubrifié de telle sorte qu'il pénètre dans le noyau du câble et assure une lubrification à long terme entre les brins. La lubrification doit être effectuée au moins tous les trois mois en fonctionnement normal.
- Tous les engrenages et les rouleaux de guidage en contact avec le câble métallique en mouvement doivent être examinés à des intervalles réguliers et lubrifiés de façon appropriée. Pour les rouleaux de guidage, utilisez une graisse standard pour roulements de roues. Pour tous les autres, utilisez une huile lubrifiante de 90 poids pour roulements. Pour tous les autres et/ou rouleaux de guidage, utilisez une huile lubrifiante de 90 WT ou une huile lubrifiante équivalente appliquée selon n'importe quelle méthode, y compris le distributeur par pompe/à pulvérisation, le pinceau, la main et/ou l'humidification.

Lisez et comprenez ces instructions avant d'utiliser l'ascenseur. Ne pas lire, comprendre et suivre ces instructions peut provoquer des blessures graves, voire mortelles.

IMPORTANT OPERATION / MAINTENANCE INSTRUCTIONS - PLEASE READ

TO RAISE LIFT

- Position vehicle level on the center of each platform.
- Set safety brakes on an even surface to level vehicle in position.
- Before raising vehicle, be sure all personnel are clear of lift and surrounding area. The vehicle direction is forward clearance.
- Raise lift to desired height by pressing pushbutton on power unit.
- Monitor visual condition of vehicle and surrounding area at all times while raising lift.
- Stop immediately if load shifts or becomes uneven.
- If any vehicle is required to be raised longer than 15 minutes by the Safety Lock, Do not allow cables to become excessively slack.
- Always make sure of Safety Locks are engaged before entering work area.

TO LOWER LIFT

- Make sure all personnel, tools, and equipment are clear of lift and surrounding area.
- Place lift in lowering position or power unit. Do not allow wheel vehicles to allow vehicle clearance for loads to clear.
- Press and hold Pushbutton to lower.
- Lower vehicle to the ground and holding Lowering handle.
- When lowering lift, make sure that all personnel and objects are kept clear.
- Always keep a clear line of sight on lift while lowering.
- Always make sure safety locks are disengaged. If one of the locks inadvertently engages on descent, lift and/or vehicle may drop causing personal injury or death.

REQUIRED MONTHLY MAINTENANCE

- Consult operation manual for factory recommended maintenance.
- Adjust lift cables to insure lift raises level and Safety Locks engage simultaneously.
- Check all mechanical connections, bolts and pins to insure proper mounting.
- Visually inspect Safety Locks for proper operation.
- Visually inspect components. Do not use lift if components show signs of breakage or other deterioration.
- Inspect all wheel balls, adjust as necessary.
- Check tracks for rips and tears.
- Inspect all lifts and other features to make sure they are properly secured.
- Make a visual inspection of all moving parts and check for signs of excessive wear.
- Inspect all lifts and/or vehicle lift and/or vehicle operation.

⚠ WARNING

Warning: If a lift falls or tilts or the component of the lift is defective, the lift may fall or tilt and cause serious injury or death.

- Never operate lift with people or equipment on it.
- Never exceed rated capacity.
- Always ensure safety locks are engaged before attempting to make work on lift or vehicle.
- Do not use lift elevated unless engaged on Safety Locks.
- Do not touch the electric motor to lift and/or vehicle or motor electrical system while operating lift or vehicle. If the motor electrical system is not properly grounded, it may cause personal injury or death.

⚠ ATTENTION

Attention: Le basculement, le basculement ou le défilement d'un composant de l'ascenseur peut causer des blessures graves, voire mortelles.

- N'opérez jamais l'ascenseur avec des personnes ou des équipements sur lui.
- N'excédez jamais la capacité nominale.
- Assurez-vous que les verrous de sécurité sont engagés avant de travailler sur l'ascenseur ou le véhicule.
- N'utilisez pas l'ascenseur ou le véhicule si les câbles de levage ou les composants de l'ascenseur ne sont pas correctement installés.

PN 5905556

⚠ CAUTION

Lift to be used by trained operator ONLY.

⚠ CAUTION

Authorized personnel only in lift area.

The messages and pictographs shown are generic in nature and are meant to generally represent hazards common to all automotive lifts regardless of specific style.

Funding for the development and validation of these labels was provided by the Automotive Lift Institute, PO Box 85 Cortland, NY 13045.

Replacement label sets may be obtained from the original lift manufacturer and ALI's member companies. They are protected by copyright. www.ali.org © 2013 by ALI, Inc.

⚠ WARNING

Clear area if vehicle is in danger of falling.

⚠ WARNING

Remain clear of lift when raising or lowering vehicle.

⚠ WARNING

Keep feet clear of pinch points when lift is moving.

⚠ WARNING

Keep feet clear of lift while lowering.

⚠ WARNING

Do not override self-lowering lift controls.

⚠ WARNING

Check wheel to prevent vehicle movement.

The messages and pictographs shown are generic in nature and are meant to generally represent hazards common to all automotive lifts regardless of specific style.

Funding for the development and validation of these labels was provided by the Automotive Lift Institute, PO Box 85 Cortland, NY 13045.

Replacement label sets may be obtained from the original lift manufacturer and ALI's member companies. They are protected by copyright. www.ali.org © 2013 by ALI, Inc.

NOTICE

Read operating and safety manuals before using lift.

NOTICE

Proper maintenance and inspection is necessary for safe operation.

NOTICE

Do not operate a damaged lift.

The messages and pictographs shown are generic in nature and are meant to generally represent hazards common to all automotive lifts regardless of specific style.

Funding for the development and validation of these labels was provided by the Automotive Lift Institute, PO Box 85 Cortland, NY 13045.

Replacement label sets may be obtained from the original lift manufacturer and ALI's member companies. They are protected by copyright. www.ali.org © 2013 by ALI, Inc.

PN 5905103

⚠ DANGER

THE MAXIMUM LIFTING CAPACITY FOR THIS LIFT IS DESCRIBED BELOW

Maximum Lifting Capacity

14000 lbs. 6350 Kg.

Max. Lifting Cap. / Front of Lift Center

7000 lbs. 3175 Kg.

Max. Lifting Cap. / Rear of Lift Center

7000 lbs. 3175 Kg.

Exceeding the weight capacity of this lift can damage lift and/or property and may cause personal harm, injury or death to operators and/or bystanders. All vehicles MUST be positioned on lift with CENTER OF GRAVITY midway between adapters and/or centered on runways. Damage to lift due to overloading or misuse IS NOT covered under warranty.

LA CAPACITÉ DE LEVAGE MAXIMUM POUR CE LEVAGE EST DÉCRIT CI-DESSOUS

Capacité de Levage Maximale

14000 lbs. 6350 Kg.

Max. Capuchon De Levage. / Avant du centre de relèvement

7000 lbs. 3175 Kg.

Max. Capuchon De Levage. / Arrière du centre de levage

7000 lbs. 3175 Kg.

Le dépassement de la capacité de poids de cet élévateur peut endommager l'ascenseur et / ou les biens et peut causer des dommages corporels, des blessures voire la mort aux opérateurs et / ou aux passants. Tous les véhicules DOIVENT être placés sur l'élévateur avec le CENTRE DE GRAVITÉ à mi-chemin entre les adaptateurs et / ou au centre des pistes. Dommages à soulever dus à la surcharge ou une mauvaise utilisation N'EST PAS couvert par la garantie.

P/N 5905557

⚠ ATTENTION

MAXIMUM LIFTING CAPACITY

CAPACITÉ DE LEVAGE MAXIMUM

14000 Lbs.

6350 Kg.

PN

P/N 5905665

49

F

BP BendPak 1645 Lemonwood Dr.
Santa Paula, CA USA
www.BendPak.com

LIFT TYPE: Surface Mount **MANUFACTURER:** BendPak. See data plate for product details

POWER: Electric/Hydraulic **INSTALLATION:** See manual or contact factory

Safety Instructions: If attachments, accessories, or configuration-modifying components that are located in the load path affect operation of the lift, affect the lift electrical listing, or affect intended vehicle accommodation are used on this lift and, if they are not certified for use on this lift, then the certification of this lift shall become null and void. Contact the participant for information pertaining to certified attachments, accessories, or configuration-modifying components.

BendPak lifts are supplied with concrete fasteners meeting the criteria as prescribed by ASTM E488/ E488M-18. Lift buyers are responsible for any special regional, structural, and/or seismic anchoring requirements specified by any other agencies and/or codes such as the Uniform Building Code (UBC) and/or International Building Code (IBC).

The manufacture, use, sale, or import of this product may be subject to one or more United States

PN 5905940

G

NOTICE

If attachments, accessories, or configuration modifying components used on this lift are located in the load path and affect operation of the lift, affect the lift electrical listing, or affect intended vehicle accommodation; and if they are not certified for use on this lift, then the certification of this lift shall become null and void. Contact the participant for information pertaining to certified attachments, accessories, or configuration modifying components.

www.autolift.org ©2011 by ALI, Inc. ALI / WLSIA01

PN 5905377

H

WARNING

SLIPPERY WHEN WET OR ICY

Use caution when driving onto wet or icy drive-up ramps and platforms. **DO NOT** walk on lift surfaces that are wet or icy.

AVERTISSEMENT

GLISSANT LORSQU'IL EST MOUILLÉ OU GLACÉ

Soyez prudent lorsque vous conduisez sur des rampes d'accès mouillées ou verglacées et les plateformes. **NE PAS** marcher sur des surfaces de levage humides ou glacées.

PN 5905 338

PN 5905138

I

CERTIFIED AUTOMOTIVE LIFT



INDEPENDENTLY TESTED
ALI
CERTIFIED
AND VALIDATED

ALI CERTIFIED

To the provisions of
ANSI/ALI ALCVTY-2017
SAFETY REQUIREMENTS FOR
CONSTRUCTION, TESTING
AND VALIDATION

Automotive Lift Institute, Inc. | Cortland, NY 13045

MET LISTED

Conforms to
ANSI/UL 201
SAFETY STANDARD FOR
GARAGE EQUIPMENT



MET LISTED
C MET US

Certified to
CAN/CSA C22.2 NO.68
MOTOR OPERATED APPLIANCES
(HOUSEHOLD & COMMERCIAL)

MET Laboratories, Inc.
BALTIMORE, MD 21220

Certification Label Serial Number



AL00617000M

PN 5905654

FOR ALI APPROVED LIFTS ONLY



PN 5906044

M

CALIFORNIA PROPOSITION 65

⚠ WARNING ⚠

WARNING! This product can expose you to chemicals including styrene and vinyl chloride which are on the list of over 900 chemicals identified by the State of California to cause cancer, birth defects or reproductive harm. ALWAYS use this product in accordance with the manufacturer's instructions. For more information, go to www.p65warnings.ca.gov.

PN 5905775

PN 5905775

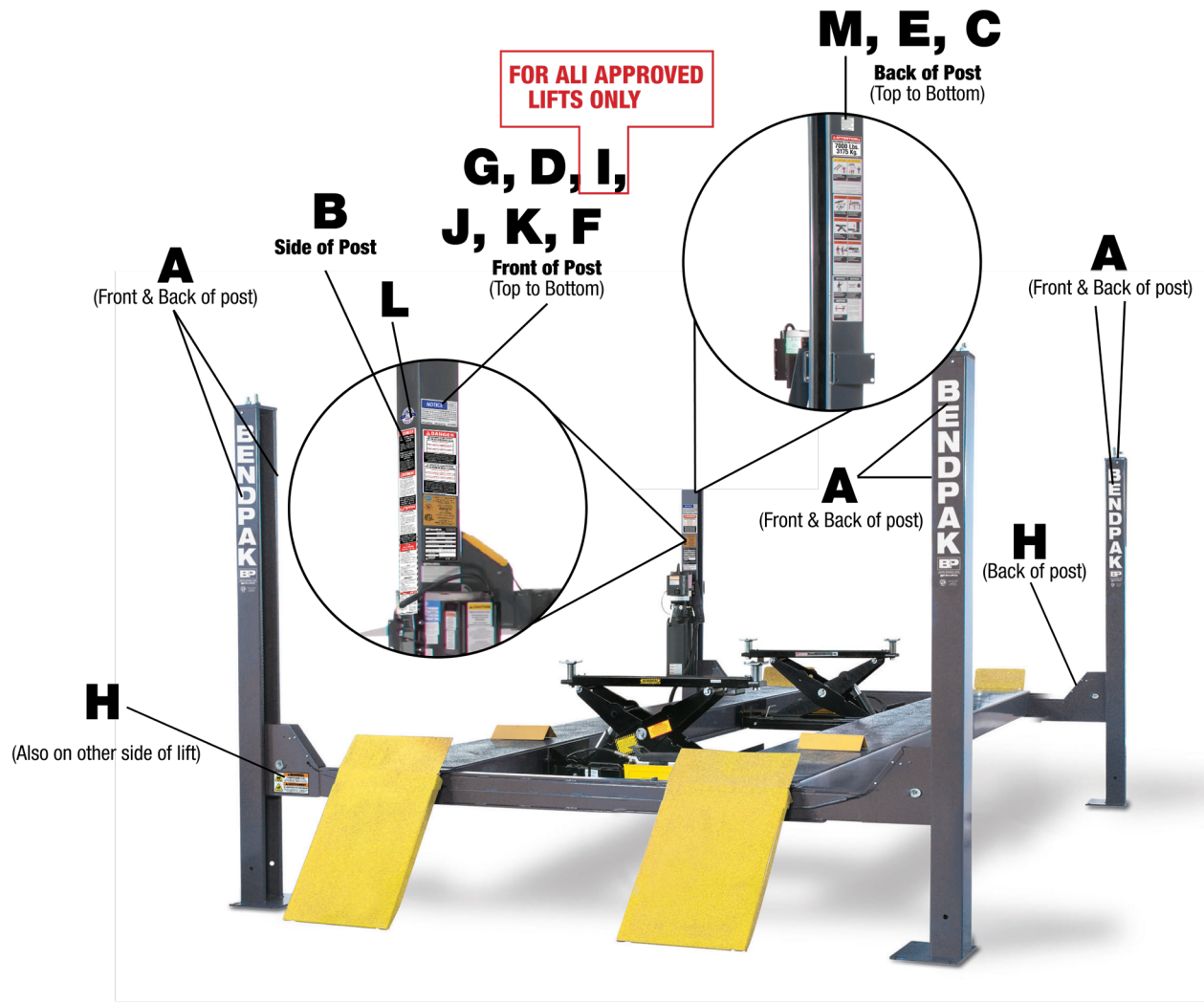

Views of Powerside Post

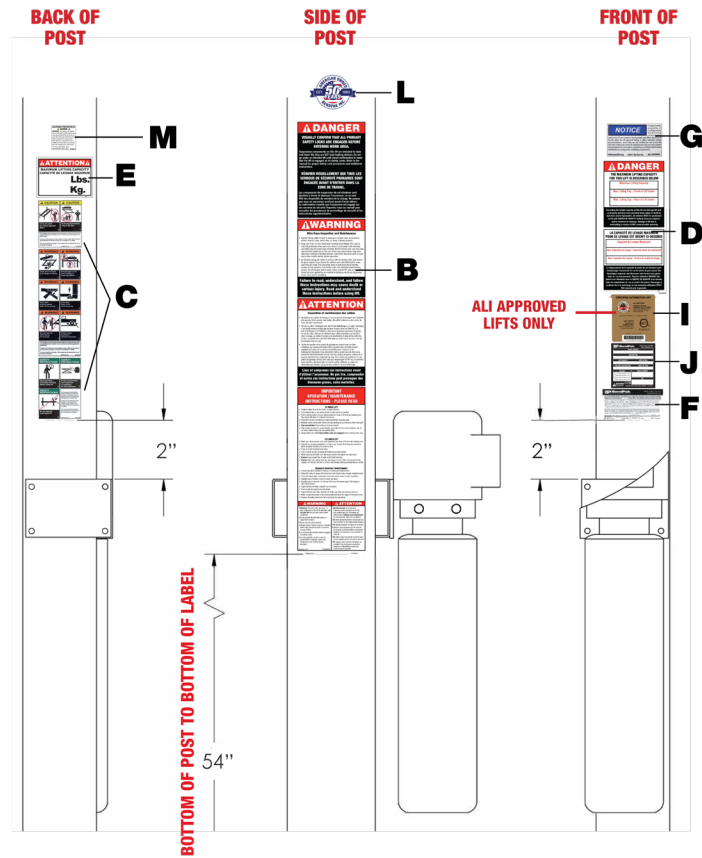

Drawings

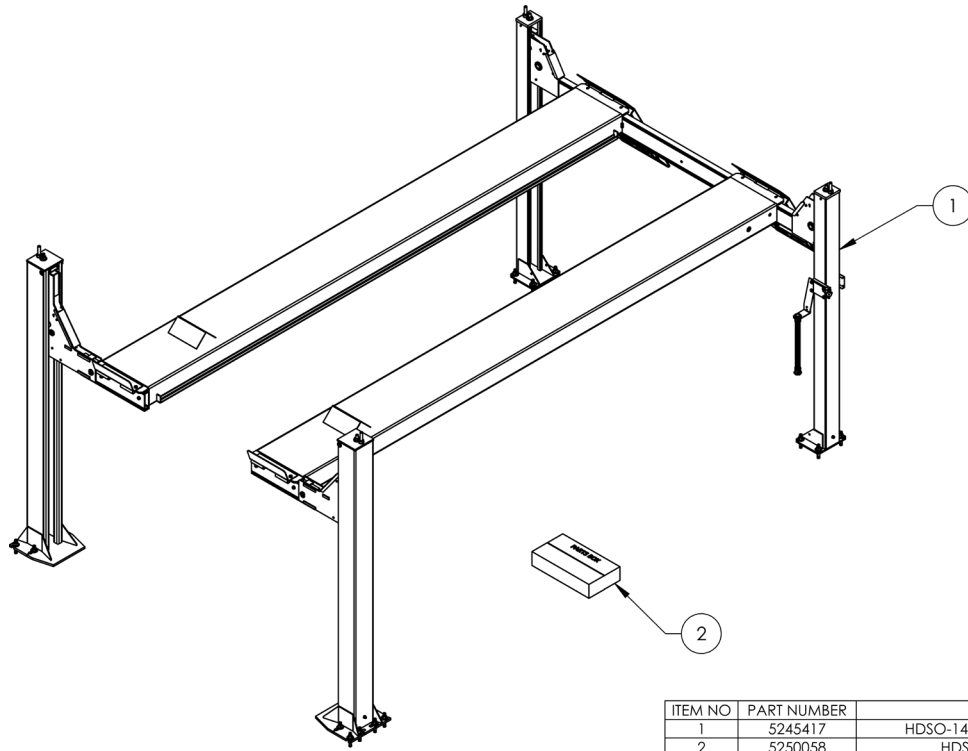

ITEM NO	PART NUMBER	DESCRIPTION	QTY	REV
1	5245417	HDSO-14P LIFT SUPERSTRUCTURE	1	T
2	5250058	HDSO-14P PARTS BOX	1	J

DO NOT SCALE DRAWING		NAME	DATE	 1645 LEMONWOOD DR. SANTA PAULA, CA 93060
DRAWN	TM	09/23/2016		
DIMENSIONS ARE IN MM		CHECKED		TITLE: HDSO-14P PRODUCTION LIFT VER D (CE CERT) SIZE DWG. NO. REV A 5260583 Y
THIRD ANGLE PROJECTION				
PROPRIETARY AND CONFIDENTIAL THE INFORMATION CONTAINED IN THIS DRAWING IS THE SOLE PROPERTY OF BENDPAK INC. ANY REPRODUCTION IN PART OR AS A WHOLE WITHOUT THE WRITTEN PERMISSION OF BENDPAK INC. IS PROHIBITED.				SCALE: 1:40

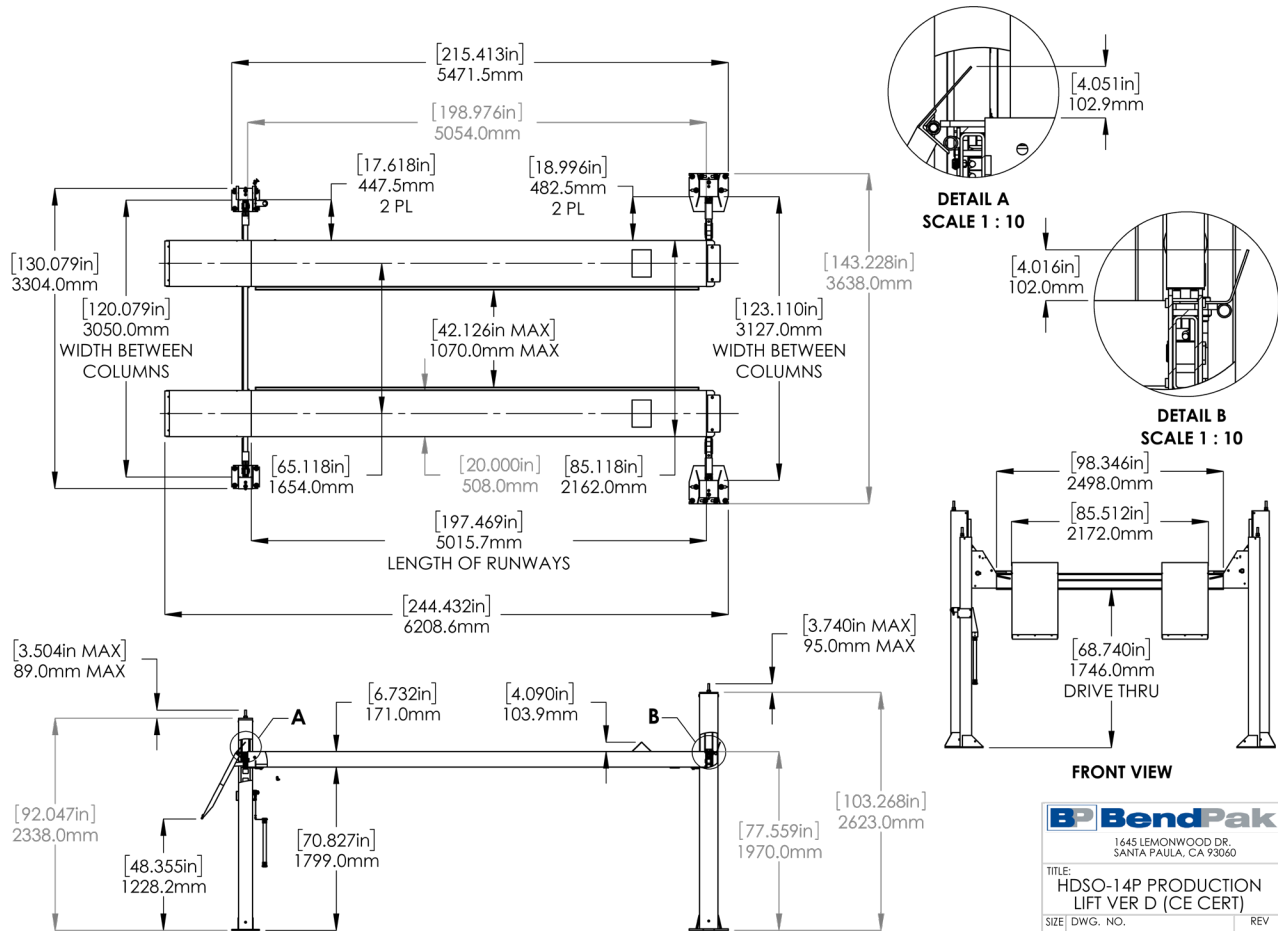

 1645 LEMONWOOD DR. SANTA PAULA, CA 93060	
TITLE: HDSO-14P PRODUCTION LIFT VER D (CE CERT)	
SIZE DWG. NO.	REV
A 5260583	Y
SCALE: 1:55	
SHEET 2 OF 3	

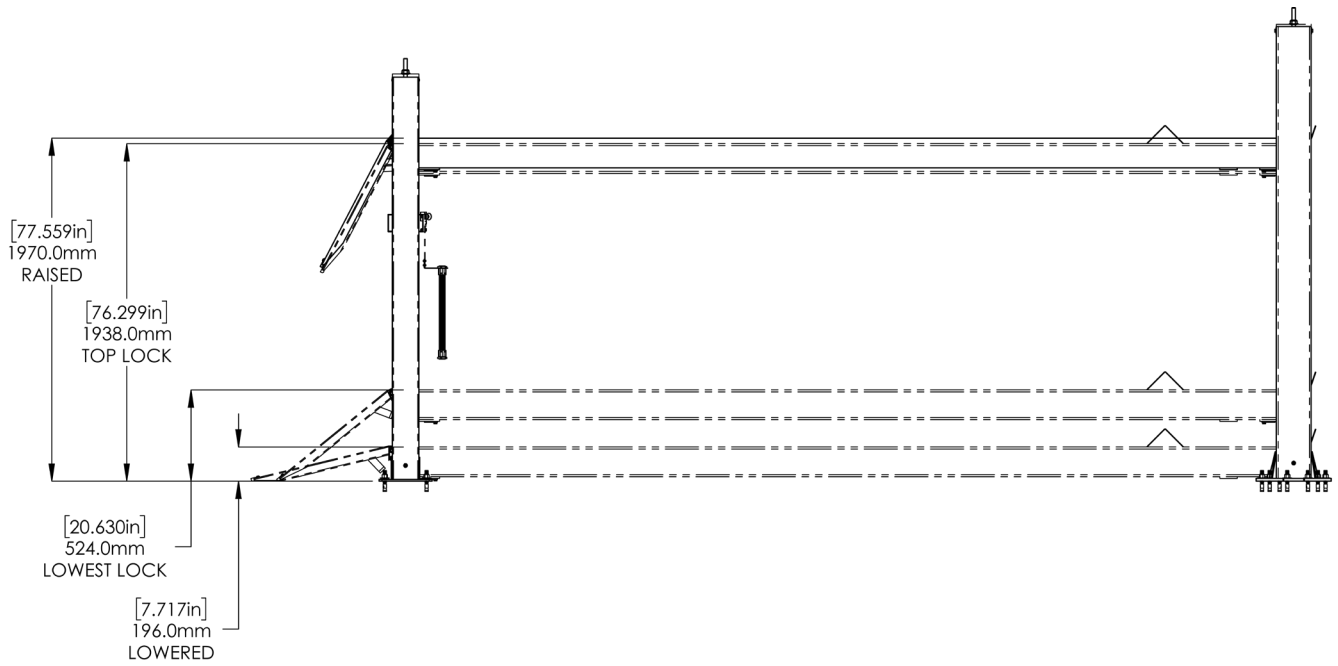

BendPak.
 1645 LEMONWOOD DR.
 SANTA PAULA, CA 93060

TITLE: HDSO-14P PRODUCTION LIFT VER D (CE CERT)

SIZE DWG. NO. REV
A 5260583 Y

SCALE: 1:30 SHEET 3 OF 3

1. DIMENSIONS SHOWN ARE WITH THE LOCK LADDERS ADJUSTED ALL THE WAY UP

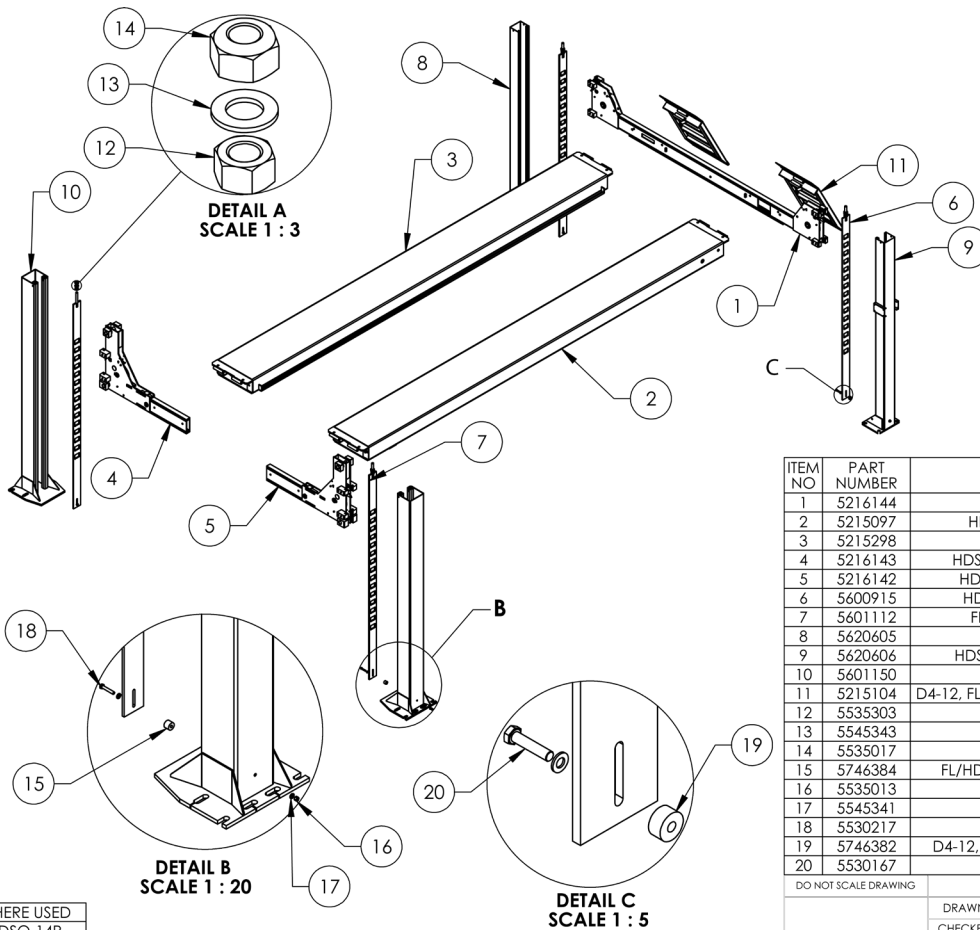

WHERE USED
HDSO-14P

ITEM NO	PART NUMBER	DESCRIPTION	QTY	REV
1	5216144	HDSO-14 CROSSTUBE ASSEMBLY	1	A
2	5215097	HDSO-14P POWER SIDE RAMP ASSEMBLY	1	U
3	5215298	HDSO-14P OFF SIDE RAMP ASSEMBLY	1	K
4	5216143	HDSO-14 RIGHT FRONT CARRIAGE ASSEMBLY	1	A
5	5216142	HDSO-14 LEFT FRONT CARRIAGE ASSEMBLY	1	A
6	5600915	HDS/HDSO-14 SAFETY LADDER WELDMENT	2	B
7	5601112	FL/HDSO-14 SAFETY LADDER WELDMENT	2	C
8	5620605	HDS/HDSO-14 POST WELDMENT	1	C
9	5620606	HDS/HDSO-14 POWER SIDE POST WELDMENT	1	C
10	5601150	HDSO-14 POST WELDMENT	2	B
11	5215104	D4-12, FL/HD/HDS/HDSO-14 DRIVE UP RAMP ASSEMBLY	2	E
12	5535303	NUT M20 x 2.5	4	-
13	5545343	WASHER, M20 FLAT	4	-
14	5535017	NUT M20 x 2.5 NL	4	-
15	5746384	FL/HDS-14 SPACER, SAFETY LADDER, 23.5mm LG	2	A
16	5535013	NUT M10 x 1.5 NL	4	-
17	5545341	WASHER M10 x Ø20 FLAT	8	-
18	5530217	HHB M10 x 1.5 x 58	2	-
19	5746382	D4-12, HDS-14 SPACER, SAFETY LADDER, 15mm LG	2	A
20	5530167	HHB M10 x 1.5 x 45mm	2	-

DO NOT SCALE DRAWING

NAME DATE
 DRAWN TM 09/23/2016

CHECKED

BendPak.
 1645 LEMONWOOD DR.
 SANTA PAULA, CA 93060

TITLE: HDSO-14P LIFT SUPERSTRUCTURE

SIZE DWG. NO. REV
A 5245417 T

SCALE: 1:55 SHEET 1 OF 1

THIRD ANGLE PROJECTION

PROPRIETARY AND CONFIDENTIAL
 THE INFORMATION CONTAINED IN THIS DRAWING IS THE SOLE PROPERTY OF BENDPAK INC. ANY REPRODUCTION IN PART OR AS A WHOLE WITHOUT THE WRITTEN PERMISSION OF BENDPAK INC. IS PROHIBITED.

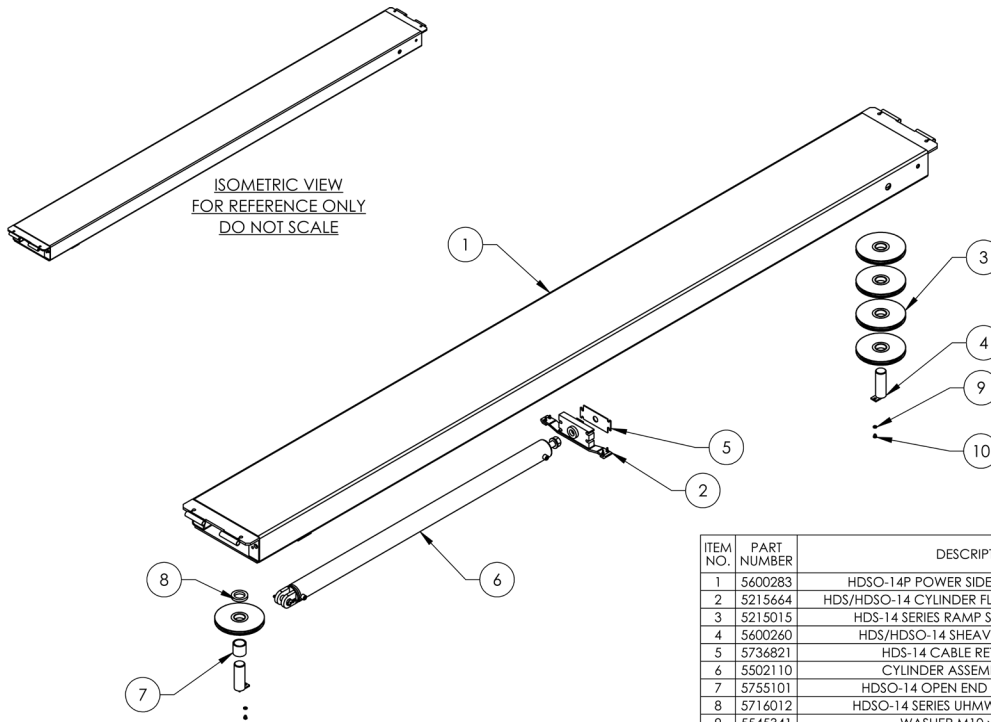

ISOMETRIC VIEW
FOR REFERENCE ONLY
DO NOT SCALE

WHERE USED
HDSO-14P

ITEM NO.	PART NUMBER	DESCRIPTION	QTY	REV
1	5600283	HDSO-14P POWER SIDE RAMP WELDMENT	1	E
2	5215664	HDS/HDSO-14 CYLINDER FLANGE ARM ASSEMBLY	1	C
3	5215015	HDS-14 SERIES RAMP SHEAVE ASSEMBLY	5	C
4	5600260	HDS/HDSO-14 SHEAVE PIN WELDMENT	2	C
5	5736821	HDS-14 CABLE RETAINER PLATE	1	A
6	5502110	CYLINDER ASSEMBLY Ø3.5 x 70	1	K
7	5755101	HDSO-14 OPEN END SHEAVE SPACER	1	B
8	5716012	HDSO-14 SERIES UHMW SHEAVE SPACER	1	B
9	5545341	WASHER M10 x Ø20 FLAT	2	--
10	5530281	HHB M10 x 1.5 x 10	2	--

DO NOT SCALE DRAWING		NAME	DATE	BendPak. 1645 LEMONWOOD DR. SANTA PAULA, CA 93060
DRAWN	GJZ	11/17/2008		
CHECKED	OR	09/15/2021		
DIMENSIONS ARE IN MM		THIRD ANGLE PROJECTION		TITLE: HDSO-14P POWER SIDE RAMP ASSEMBLY
	<small>PROPRIETARY AND CONFIDENTIAL THE INFORMATION CONTAINED IN THIS DRAWING IS THE SOLE PROPERTY OF BENDPAK INC. ANY REPRODUCTION IN PART OR AS A WHOLE WITHOUT THE WRITTEN PERMISSION OF BENDPAK INC. IS PROHIBITED.</small>		SIZE DWG. NO.	REV
			A 5215097	U
			SCALE: 1:25	SHEET 1 OF 2

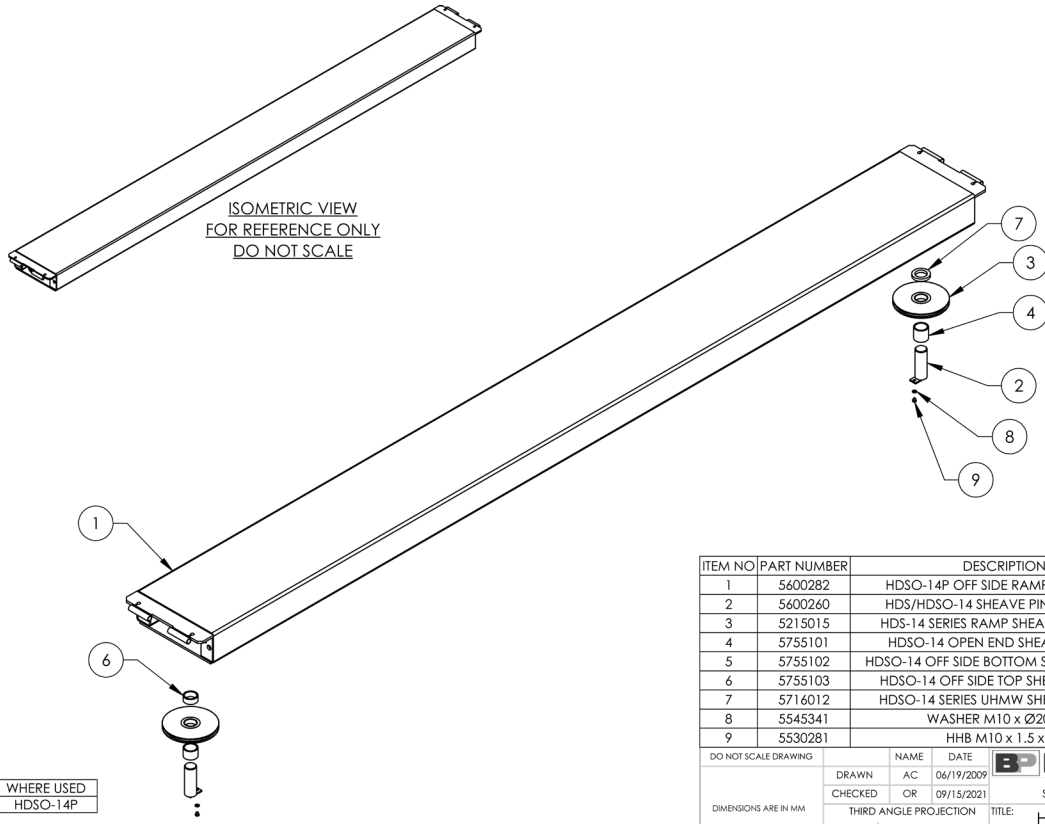

ISOMETRIC VIEW
FOR REFERENCE ONLY
DO NOT SCALE

WHERE USED
HDSO-14P

ITEM NO.	PART NUMBER	DESCRIPTION	QTY	REV
1	5600282	HDSO-14P OFF SIDE RAMP WELDMENT	1	E
2	5600260	HDS/HDSO-14 SHEAVE PIN WELDMENT	2	C
3	5215015	HDS-14 SERIES RAMP SHEAVE ASSEMBLY	2	C
4	5755101	HDSO-14 OPEN END SHEAVE SPACER	1	B
5	5755102	HDSO-14 OFF SIDE BOTTOM SHEAVE SPACER	1	A
6	5755103	HDSO-14 OFF SIDE TOP SHEAVE SPACER	1	A
7	5716012	HDSO-14 SERIES UHMW SHEAVE SPACER	1	B
8	5545341	WASHER M10 x Ø20 FLAT	2	--
9	5530281	HHB M10 x 1.5 x 10	2	--

DO NOT SCALE DRAWING		NAME	DATE	BendPak. 1645 LEMONWOOD DR. SANTA PAULA, CA 93060
DRAWN	AC	06/19/2009		
CHECKED	OR	09/15/2021		
DIMENSIONS ARE IN MM		THIRD ANGLE PROJECTION		TITLE: HDSO-14P OFF SIDE RAMP ASSEMBLY
	<small>PROPRIETARY AND CONFIDENTIAL THE INFORMATION CONTAINED IN THIS DRAWING IS THE SOLE PROPERTY OF BENDPAK INC. ANY REPRODUCTION IN PART OR AS A WHOLE WITHOUT THE WRITTEN PERMISSION OF BENDPAK INC. IS PROHIBITED.</small>		SIZE DWG. NO.	REV
			A 5215298	K
			SCALE: 1:22	SHEET 1 OF 1

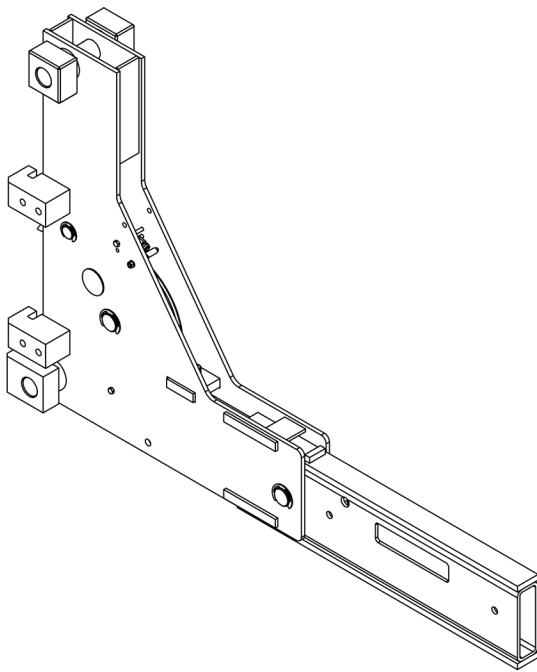

WHERE USED
HDSO-14P
HDSO-14AX

ITEM NO	PART NUMBER	DESCRIPTION	QTY	REV
1	5601817	HDSO-14 SHORT CROSSTUBE LEFT WELDMENT	1	A
2	5746080	HDSO-14 SAFETY PIN	1	D
3	5600044	4 POST LIGHT DUTY SLACK SAFETY WELDMENT	1	F
4	5575380	D4-12, HD/HDS/HDSO-14 SAFETY ROLLER	1	C
5	5716031	HDSO-14 POLYETHYLENE SLIDE BLOCK	4	D
6	5215013	HDS-14 CROSSTUBE SHEAVE ASSEMBLY	1	B
7	5601110	HDSO-14 LEFT CARRIAGE WELDMENT	1	E
8	5600173	D4-12, HD/HDS/HDSO-14 SHEAVE PIN WELDMENT	2	G
9	5540275	E RING Ø25mm OD DIN 6799 0250	4	-
10	5530694	HHB M6 x 1.0 x 75	3	-
11	5545005	WASHER, M6 x 12mm FLAT	2	-
12	5535112	NUT M6 x 1.0	3	-
13	5540065	SPRING Ø13mm x 90mm, SLACK SAFETY	1	A
14	5540002	E RING Ø1.375" OD TRUARC X5133-137	2	-
15	5505625	FEMALE ROD END M6 x 33	1	-
16	5502195	AIR CYLINDER, Ø19mm x 25 STROKE	1	-
17	5550087	FIG ELB -04 COMP x -02 NPT	1	-
18	5530756	HHB M6 x 1.0 x 25mm	1	-
19	5505030	PUSH-ON CLIP Ø10mm SS	1	-
20	5530090	SSS M20 x 2.5 x 50	1	-
21	5600760	D4-12, HD/HDS LIGHT DUTY SAFETY WELDMENT	1	C
22	5716019	HDSO-14 BUTTON SLIDE	2	B
23	5716022	HDSO-14 CARRIAGE ROLLER BEARING	2	A
24	5755136	AIR CYLINDER SPACER 12mm	1	A
25	5755137	AIR CYLINDER SPACER 25mm	1	A
26	5535357	NUT M6 x 1.0 NL	1	-
27	5716038	HDSO-14 POLYETHYLENE SLIDE BLOCK, TOP	2	B
28	5716039	HDSO-14 POLYETHYLENE SLIDE BLOCK, BOTTOM	2	B
29	5755159	HDSO-14 CROSSTUBE SPACER Ø16 x Ø10 x 52	1	A
30	5535230	NUT 1/4-28 JN	1	-

DO NOT SCALE DRAWING

DRAWN	TM	05/11/2022	 1645 LEMONWOOD DR. SANTA PAULA, CA 93060
CHECKED			

DIMENSIONS ARE IN MM

THIRD ANGLE PROJECTION

TITLE: HDSO-14 LEFT FRONT CARRIAGE ASSEMBLY

SIZE DWG. NO. REV

A 5216142 A

SCALE: 1:8 SHEET 1 OF 2

PROPRIETARY AND CONFIDENTIAL
THE INFORMATION CONTAINED IN THIS DRAWING IS
THE SOLE PROPERTY OF BENDPAK, INC. ANY
REPRODUCTION IN PART OR AS A WHOLE WITHOUT
THE WRITTEN PERMISSION OF BENDPAK, INC. IS
PROHIBITED.

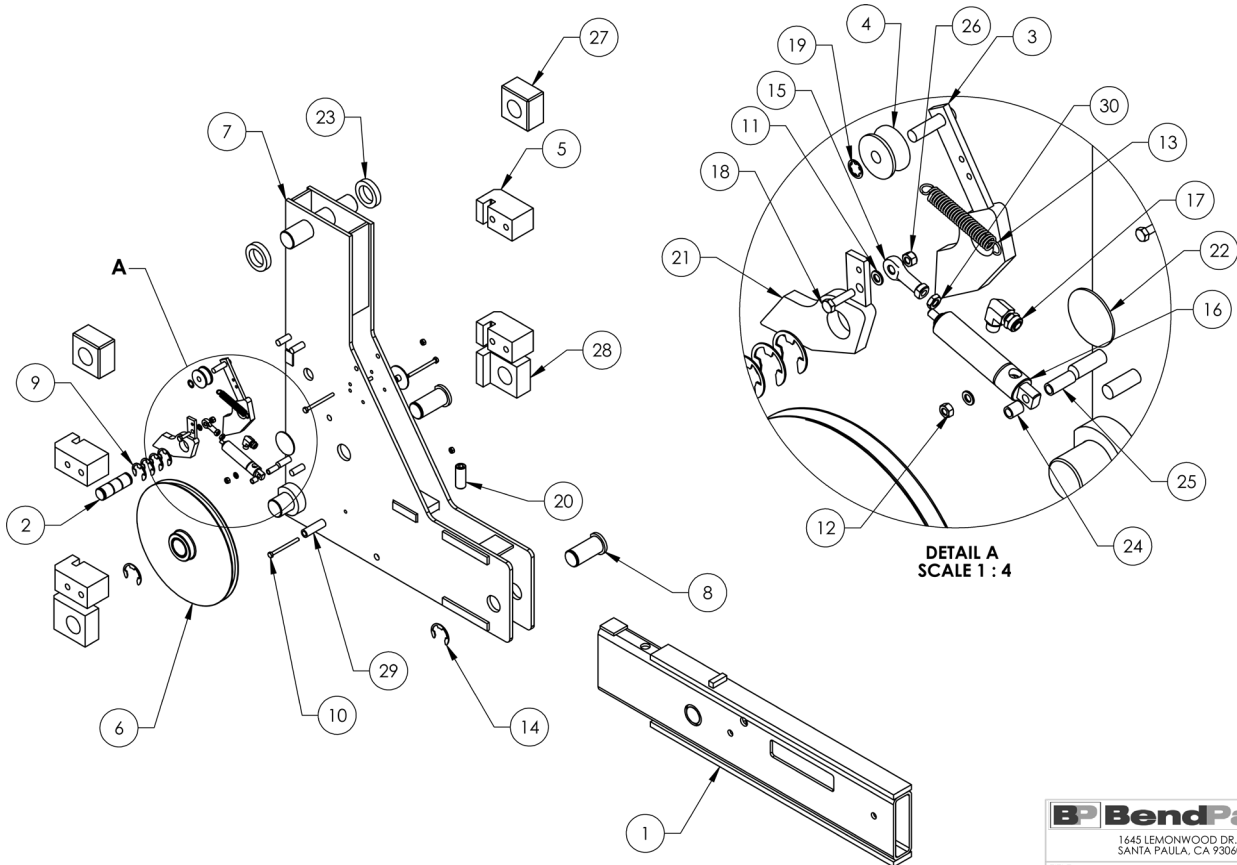

1645 LEMONWOOD DR.
SANTA PAULA, CA 93060

TITLE: HDSO-14 LEFT FRONT CARRIAGE ASSEMBLY

SIZE DWG. NO. REV

A 5216142 A

SCALE: 1:10 SHEET 2 OF 2

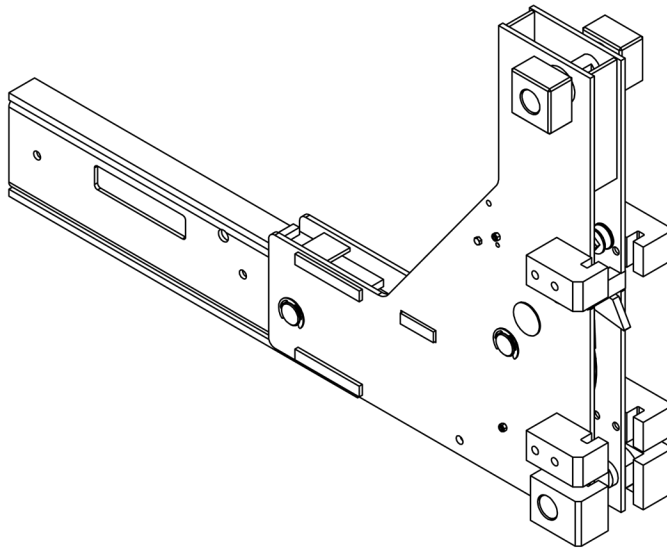

ITEM NO.	PART NUMBER	DESCRIPTION	QTY	REV
1	5601818	HDSO-14 SHORT CROSSTUBE RIGHT WELDMENT	1	A
2	5600044	4 POST LIGHT DUTY SLACK SAFETY WELDMENT	1	F
3	5575380	D4-12, HD/HDS/HDSO-14 SAFETY ROLLER	1	C
4	5716031	HDSO-14 POLYETHYLENE SLIDE BLOCK	4	D
5	5215013	HDS-14 CROSSTUBE SHEAVE ASSEMBLY	1	B
6	5601111	HDSO-14 RIGHT CARRIAGE WELDMENT	1	E
7	5746080	HDSO-14 SAFETY PIN	1	D
8	5600173	D4-12, HD/HDS/HDSO-14 SHEAVE PIN WELDMENT	2	G
9	5540275	E RING Ø25mm OD DIN 6799 0250	4	-
10	5530694	HHB M6 x 1.0 x 75	3	-
11	5545005	WASHER, M6 x 12mm FLAT	2	-
12	5535112	NUT M6 x 1.0	1	-
13	5540065	SPRING Ø13mm x 90mm, SLACK SAFETY	1	A
14	5540002	E RING Ø1.375" OD TRUARC X5133-137	2	-
15	5505625	FEMALE ROD END M6 x 33	1	-
16	5502195	AIR CYLINDER, Ø19mm x 25 STROKE	1	-
17	5550087	FTG ELB -04 COMP x -02 NPT	1	-
18	5505030	PUSH-ON CLIP Ø10mm SS	1	-
19	5530090	SSS M20 x 2.5 x 50L	1	-
20	5530756	HHB M6 x 1.0 x 25mm	1	-
21	5600760	D4-12, HD/HDS LIGHT DUTY SAFETY WELDMENT	1	C
22	5716019	HDSO-14 BUTTON SLIDE	2	B
23	5716022	HDSO-14 CARRIAGE ROLLER BEARING	2	A
24	5755136	AIR CYLINDER SPACER 12mm	1	A
25	5755137	AIR CYLINDER SPACER 25mm	1	A
26	5535357	NUT M6 x 1.0 NL	3	-
27	5716039	HDSO-14 POLYETHYLENE SLIDE BLOCK, BOTTOM	2	B
28	5716038	HDSO-14 POLYETHYLENE SLIDE BLOCK, TOP	2	B
29	5755159	HDSO-14 CROSSTUBE SPACER Ø16 x Ø10 x 52	1	A
30	5535230	NUT 1/4-28 JN	1	-

WHERE USED
HDSO-14P
HDSO-14AX

DO NOT SCALE DRAWING	NAME	DATE	 1645 LEMONWOOD DR. SANTA PAULA, CA 93060
	DRAWN	TM 05/11/2022	
	CHECKED		TITLE: HDSO-14 RIGHT FRONT CARRIAGE ASSEMBLY SIZE DWG. NO. REV A 5216143 A
	THIRD ANGLE PROJECTION		
DIMENSIONS ARE IN MM			SCALE: 1:8
			SHEET 1 OF 2

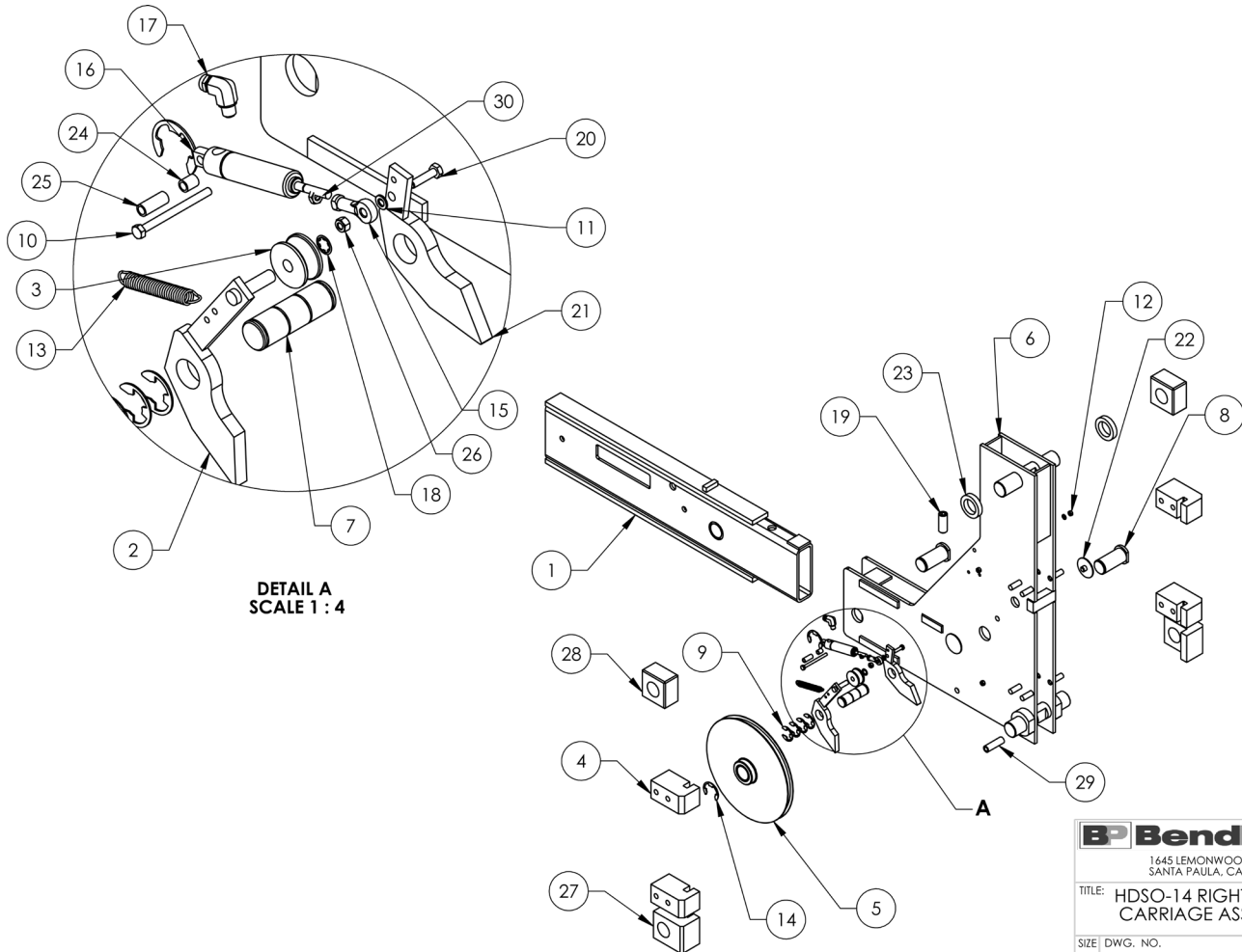

 1645 LEMONWOOD DR. SANTA PAULA, CA 93060		
TITLE: HDSO-14 RIGHT FRONT CARRIAGE ASSEMBLY		
SIZE	DWG. NO.	REV
A	5216143	A
SCALE: 1:12		SHEET 2 OF 2

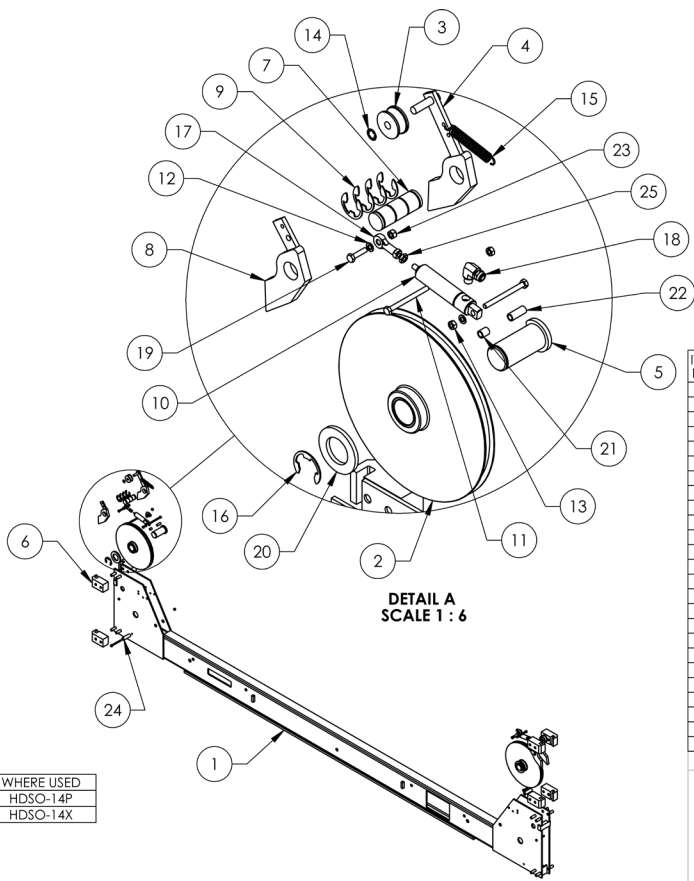

ITEM NO.	PART NUMBER	DESCRIPTION	QTY	REV
1	5601816	HDSO-14 CROSSTUBE WELDMENT	1	A
2	5215013	HDS-14 CROSSTUBE SHEAVE ASSEMBLY	2	B
3	5575380	D4-12, HD/HDS/HDSO-14 SAFETY ROLLER	2	C
4	5600044	4 POST LIGHT DUTY SLACK SAFETY WELDMENT	2	F
5	5600173	D4-12, HD/HDS/HDSO-14 SHEAVE PIN WELDMENT	2	G
6	5716005	D4-12, HD-7/7500/9/14/HDSO-14 POLYETHYLENE SLIDE BLOCK	8	M
7	5746008	D4-12, HD/HDS-7/7500/9/14, HDSO-14 SAFETY PIN	2	D
8	5600760	D4-12, HD/HDS LIGHT DUTY SAFETY WELDMENT	2	C
9	5540275	E RING Ø25mm OD DIN 6799 0250	8	-
10	5502195	AIR CYLINDER, Ø19mm x 25 STROKE	2	-
11	5530005	HHB M6 x 1 x 70	6	-
12	5545005	WASHER, M6 x 12mm FLAT	4	-
13	5535112	NUT M6 x 1.0	4	-
14	5505030	PUSH-ON CLIP Ø10mm SS	2	-
15	5540065	SPRING Ø13mm x 90mm, SLACK SAFETY	2	A
16	5540002	E RING Ø1.375" OD TRUARC X5133-137	2	-
17	5505625	FEMALE ROD END M6 x 33	2	-
18	5550087	FTG ELB-04 COMP x-02 NPT	2	-
19	5530756	HHB M6 x 1.0 x 25mm	2	-
20	5545032	WASHER M36 x 66 FLAT	2	-
21	5755136	AIR CYLINDER SPACER 12mm	2	A
22	5755137	AIR CYLINDER SPACER 25mm	2	A
23	5535357	NUT M6 x 1.0 NL	4	-
24	5755157	D4-12, HD-7/7500/9 CROSSTUBE SPACER Ø16 x Ø10 x 50	2	A
25	5535230	NUT 1/4-28 JN	2	-

DO NOT SCALE DRAWING

DRAWN	TM	DATE	BendPak	
CHECKED	OR	04/29/2022	1645 LEMONWOOD DR. SANTA PAULA, CA 93060	
THIRD ANGLE PROJECTION			TITLE: HDSO-14 CROSSTUBE ASSEMBLY	
DIMENSIONS ARE IN MM			SIZE DWG. NO.	REV
			A	5216144
<small>PROPRIETARY AND CONFIDENTIAL THE INFORMATION CONTAINED IN THIS DRAWING IS THE SOLE PROPERTY OF BENDPAK, INC. ANY REPRODUCTION IN PART OR AS A WHOLE WITHOUT THE WRITTEN PERMISSION OF BENDPAK, INC. IS PROHIBITED.</small>			SCALE: 1:25	SHEET 1 OF 1

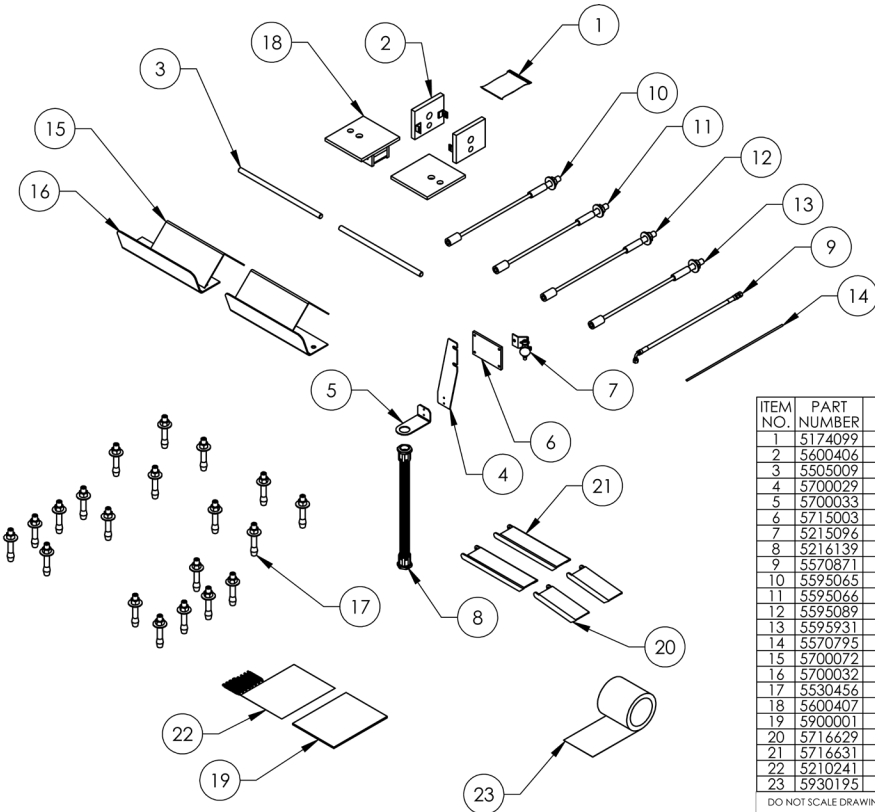

ITEM NO.	PART NUMBER	DESCRIPTION	QTY.	REV
1	5174099	HDSO-14 PARTS BAG	1	F
2	5600406	HD/HDS-14 TOP PLATE WELDMENT	2	C
3	5505009	D4-12, HD/HDS-14 DRIVE UP RAMP PIN	2	D
4	5700029	HD-SERIES FLEX TUBE BRACKET PLATE	1	F
5	5700033	HD-SERIES FLEX TUBE ANGLE	1	E
6	5715003	POWER UNIT VIBRATION DAMPENER	1	B
7	5215096	PUSH BUTTON AIR ASSEMBLY	1	G
8	5216139	FLEX TUBE KIT, UP TO 2000mm	1	A
9	5570871	HYDRAULIC HOSE ASSEMBLY Ø6.4 x 4166mm	1	B
10	5595065	HDS/HDSO-14 CABLE ASSEMBLY Ø12 x 4100mm ST	1	E
11	5595066	HDS/HDSO-14 CABLE ASSEMBLY Ø12 x 5732mm ST	1	E
12	5595089	HDSO-14P/AX CABLE ASSEMBLY Ø12 x 11302mm ST	1	D
13	5595931	HDSO-14P/AX CABLE ASSEMBLY Ø12 x 9639mm ST	1	C
14	5570795	1/4" POLY-FLO TUBING	24000mm*	--
15	5700072	WHEEL CHOCK	2	B
16	5700032	TIRE STOP	2	D
17	5530456	AB 3/4" x 4 - 3/4"	20	--
18	5600407	HDSO-14 TOP PLATE WELDMENT	2	B
19	5900001	INSTALLATION MANUAL HDSO-14P/AX	1	--
20	5716629	HDS-14 CROSSTUBE COVER, PLASTIC	2	A
21	5716631	HDSO-14 CARRIAGE CLOSEOUT COVER, PLASTIC	2	A
22	5210241	4 POST LIGHT DUTY CE PARTS BAG	1	A
23	5930195	ANTI-SLIP TAPE, 6" x 24ft	1	--

DO NOT SCALE DRAWING

DRAWN	TM	DATE	BendPak	
CHECKED	OR	05/09/2022	1645 LEMONWOOD DR. SANTA PAULA, CA 93060	
THIRD ANGLE PROJECTION			TITLE: HDSO-14P PARTS BOX	
DIMENSIONS ARE IN MM			SIZE DWG. NO.	REV
			A	5250058
<small>PROPRIETARY AND CONFIDENTIAL THE INFORMATION CONTAINED IN THIS DRAWING IS THE SOLE PROPERTY OF BENDPAK, INC. ANY REPRODUCTION IN PART OR AS A WHOLE WITHOUT THE WRITTEN PERMISSION OF BENDPAK, INC. IS PROHIBITED.</small>			SCALE: 1:20	SHEET 1 OF 1

WHERE USED
HDSO-14P

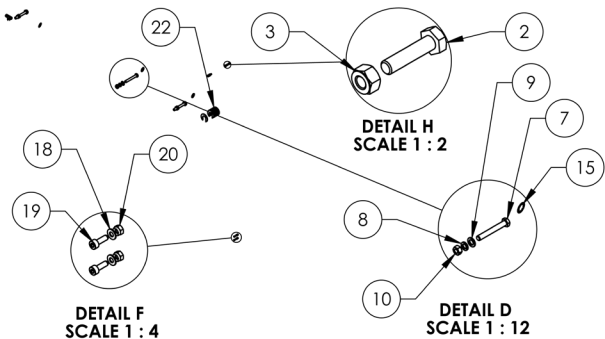
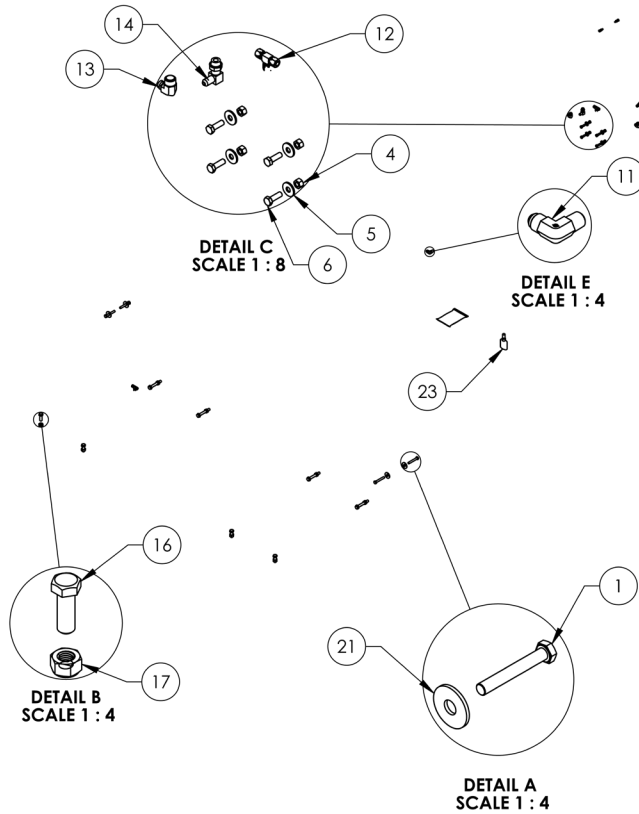

ITEM NO	PART NUMBER	DESCRIPTION	QTY	REV
1	5530767	HHB M10 x 1.5 x 70	4	-
2	5530756	HHB M6 x 1.0 x 25mm	4	-
3	5535357	NUT M6 x 1.0 NL	4	-
4	5535001	NUT M8 x 1.25 NL	4	-
5	5545340	WASHER M8 x24 FLAT	4	-
6	5530010	HHB M8 x 1.25 x 25mm ZPL	4	-
7	5530009	HHB M12 x 1.75 x 90 CL8.8	8	-
8	5545201	WASHER, M12 SPRING LOCK	8	-
9	5545347	WASHER, M12 FLAT WASHER	8	-
10	5535354	NUT, M12 x1.75	8	-
11	5550106	FTG ELB -04 JIC x 3/8" NPT	1	-
12	5550325	FTG TEE -04 COMP x -04 COMP x -04 COMP	3	-
13	5550089	FTG ELB -04 COMP x -04 NPT	2	-
14	5550008	FTG ELB -04 JIC -06L ORB	1	-
15	5505032	ROTOR CLIP Ø18mm SS	4	-
16	5530107	HHB M14 x 2.0 x 40	4	-
17	5535107	NUT M14 x 2.0 NL	4	-
18	5545009	WASHER, M4 x 9mm FLAT	2	-
19	5530008	SHCS M4 x 0.7 x 1/2 BOC	2	-
20	5535010	NUT M4 x 0.7 NL	2	-
21	5545027	WASHER M12 x Ø37	4	-
22	5545535	C WASHER SHIM FOR LIFTS	20	-
23	5580012	LIQUID PTFE THREAD SEALANT 50ml	1	-

WHERE USED
HDSO-14 SERIES

DO NOT SCALE DRAWING		NAME	DATE	BendPak 1645 LEMONWOOD DR. SANTA PAULA, CA 93060
DRAWN	AC	08/08/2008		
DIMENSIONS ARE IN MM		CHECKED	OR	09/21/2021
THIRD ANGLE PROJECTION		TITLE: HDSO-14 PARTS BAG		
		SIZE	DWG. NO.	REV
		A	5174099	F
<small>PROPRIETARY AND CONFIDENTIAL THE INFORMATION CONTAINED IN THIS DRAWING IS THE SOLE PROPERTY OF BENDPAK INC. ANY REPRODUCTION IN PART OR AS A WHOLE WITHOUT THE WRITTEN PERMISSION OF BENDPAK INC. IS PROHIBITED.</small>		SCALE: 1:30		SHEET 1 OF 1

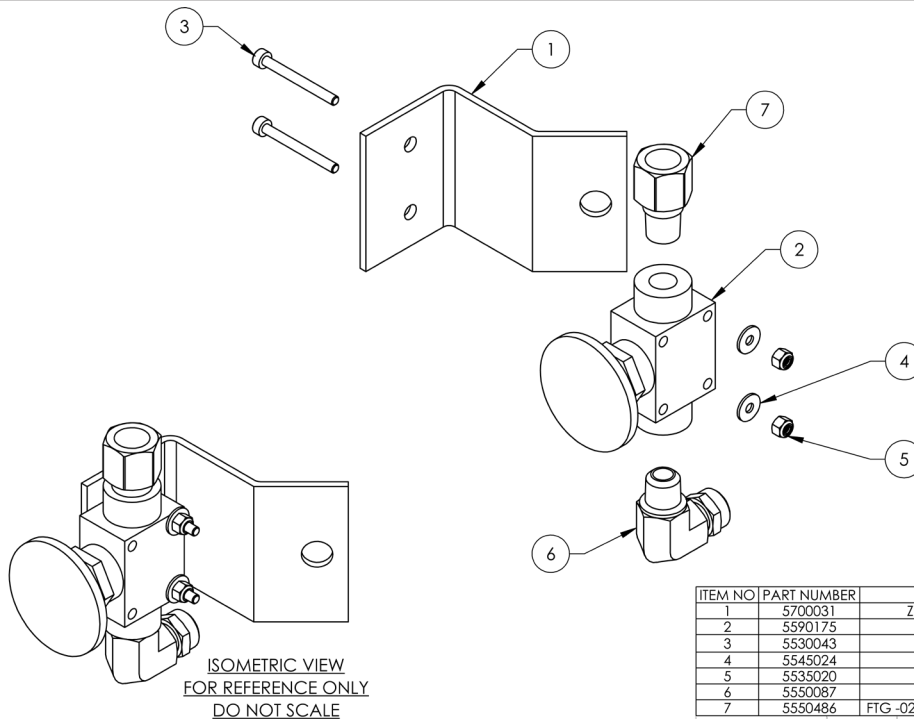

ITEM NO	PART NUMBER	DESCRIPTION	QTY	REV
1	5700031	ZERO ANGLE MOUNTING BRACKET	1	C
2	5590175	PUSH BUTTON AIR VALVE	1	-
3	5530043	SHCS M3 x 0.5 x 30	2	-
4	5545024	WASHER, M3 x 9mm FLAT	2	-
5	5535020	NUT M3 x 0.5, NL CL8	2	-
6	5550087	FTG ELB -04 COMP x -02 NPT	1	-
7	5550486	FTG -02 NPTF x -04 F NPTF, STRAIGHT EXPANDER	1	-

DO NOT SCALE DRAWING		NAME	DATE	BendPak 1645 LEMONWOOD DR. SANTA PAULA, CA 93060
DRAWN	AC	03/14/2008		
DIMENSIONS ARE IN MM		CHECKED	CA	09/02/2015
THIRD ANGLE PROJECTION		TITLE: PUSH BUTTON AIR ASSEMBLY		
		SIZE	DWG. NO.	REV
		A	5215096	G
<small>PROPRIETARY AND CONFIDENTIAL THE INFORMATION CONTAINED IN THIS DRAWING IS THE SOLE PROPERTY OF BENDPAK INC. ANY REPRODUCTION IN PART OR AS A WHOLE WITHOUT THE WRITTEN PERMISSION OF BENDPAK INC. IS PROHIBITED.</small>		SCALE: 2:3		SHEET 1 OF 1

NOTE: UNLESS OTHERWISE SPECIFIED
 1. SEE SHIPPING INSTRUCTIONS FOR FINAL PACKAGING
 2. ASSEMBLE ITEMS AS SHOWN

NEXT ASSEMBLY
D4-12 SERIES
FL14 SERIES
HD SERIES
HDS SERIES
HDSO SERIES
PL-12000DP

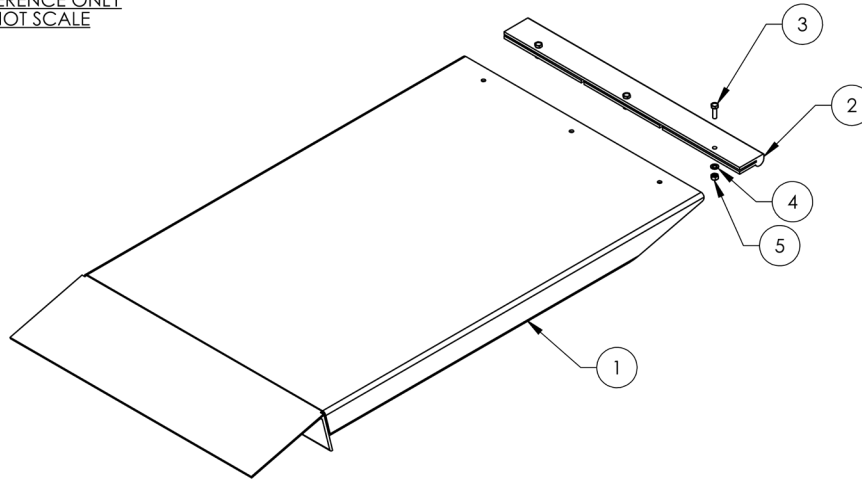
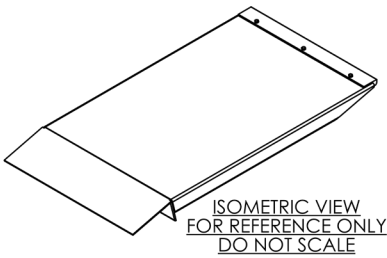

WHERE USED
D4-12 SERIES
FL14 SERIES
HD-14T
HDS-14 SERIES
HDSO-14 SERIES

NOTE: UNLESS OTHERWISE SPECIFIED

1. REFER TO MODEL FOR ADDITIONAL INFORMATION
2. SEE SHIPPING INSTRUCTIONS FOR FINAL PACKAGING
3. ASSEMBLE ITEMS AS SHOWN

ITEM NO	PART NUMBER	DESCRIPTION	QTY	REV
1	5600138	D4-12, HD/HDS/HDSO-14 DRIVE UP RAMP WELDMENT	1	H
2	5716087	HDS-14 APPROACH RAMP EDGE GUARD	1	A
3	5530093	HHB M6 x 1.0 x 20mm	3	-
4	5545005	WASHER, M6 x 12mm FLAT	3	-
5	5535357	NUT M6 x 1.0, NL CL8	3	-

NEXT ASSEMBLY	
5210743	5245284
5245081	5245285
5245082	
5245083	
5245084	
5245085	
5245095	
5245096	
5245416	
5245417	

DO NOT SCALE DRAWING

DRAWN	TM	DATE
CHECKED	OR	DATE

06/04/2008
12/13/2022

BP BendPak.
1645 LEMONWOOD DR.
SANTA PAULA, CA 93060

TITLE: D4-12, FL/HD/HDS/HDSO-14 DRIVE UP RAMP ASSEMBLY

SIZE: DWG. NO. A 5215104 REV K

SCALE: 1:8 SHEET 1 OF 2

THIRD ANGLE PROJECTION

PROPRIETARY AND CONFIDENTIAL
THE INFORMATION CONTAINED IN THIS DRAWING IS THE SOLE PROPERTY OF BENDPAK INC. ANY REPRODUCTION IN PART OR AS A WHOLE WITHOUT THE WRITTEN PERMISSION OF BENDPAK INC. IS PROHIBITED.

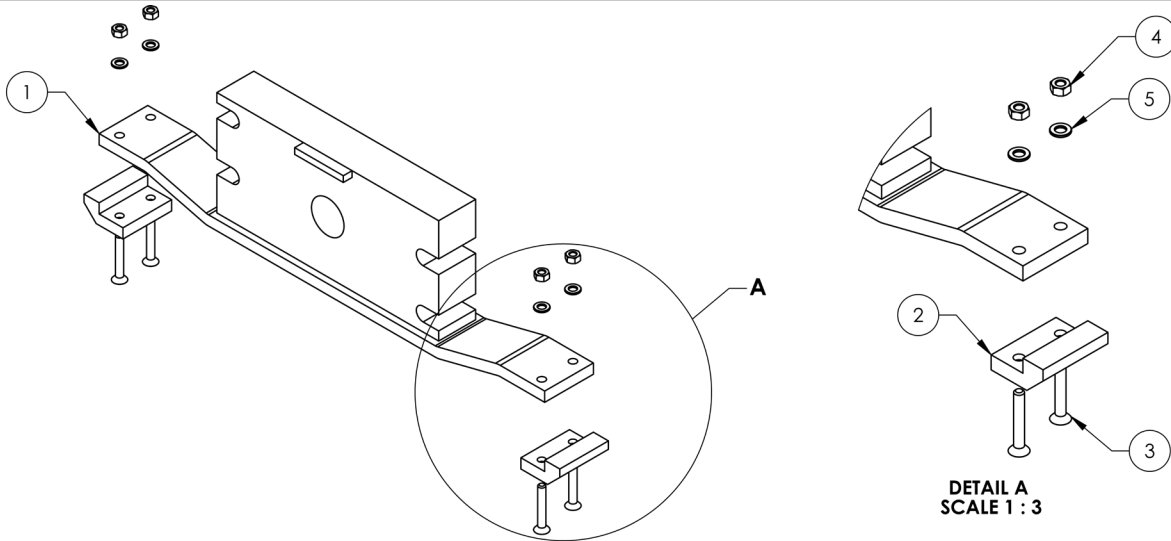

WHERE USED
HDS-14
HDS-14X
HDSO-14

NOTE: UNLESS OTHERWISE SPECIFIED

1. SEE SHIPPING INSTRUCTIONS FOR FINAL PACKAGING
2. ASSEMBLE ITEMS AS SHOWN

NEXT ASSEMBLY	
5210228	
5215072	
5215097	
5215241	

ITEM NO	PART NUMBER	DESCRIPTION	QTY	REV
1	5600924	HDS/HDSO-14 CYLINDER FLANGE ARM WELDMENT	1	A
2	5716006	HD/HDS/HDSO-14 CYLINDER FLANGE ARM SLIDE	2	F
3	5530247	FHPS M6 x 1 x 40	4	-
4	5535112	NUT M6 x 1.0	4	-
5	5545005	M6 FLAT WASHER	4	-

DO NOT SCALE DRAWING

DRAWN	TM	DATE
CHECKED	AW	DATE

08/04/2014
7/27/2017

BP BendPak.
1645 LEMONWOOD DR.
SANTA PAULA, CA 93060

TITLE: HDS/HDSO-14 CYLINDER FLANGE ARM ASSEMBLY

SIZE: DWG. NO. A 5215664 REV C

SCALE: 1:4 SHEET 1 OF 1

THIRD ANGLE PROJECTION

PROPRIETARY AND CONFIDENTIAL
THE INFORMATION CONTAINED IN THIS DRAWING IS THE SOLE PROPERTY OF BENDPAK INC. ANY REPRODUCTION IN PART OR AS A WHOLE WITHOUT THE WRITTEN PERMISSION OF BENDPAK INC. IS PROHIBITED.

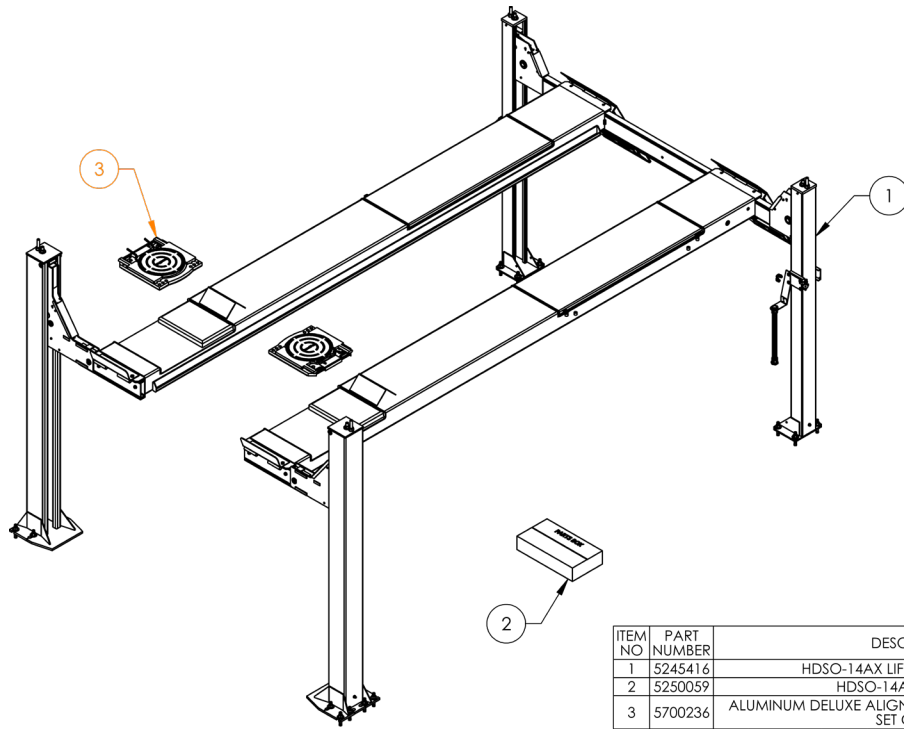

ITEM NO	PART NUMBER	DESCRIPTION	QTY	REV
1	5245416	HDSO-14AX LIFT SUPERSTRUCTURE	1	V
2	5250059	HDSO-14AX PARTS BOX	1	K
3	5700236	ALUMINUM DELUXE ALIGNMENT TURNPLATE ASSEMBLY, SET OF TWO	1	B

DO NOT SCALE DRAWING	NAME	DATE	 1645 LEMONWOOD DR. SANTA PAULA, CA 93060
	DRAWN TM	09/23/2016	
	CHECKED		
DIMENSIONS ARE IN MM	THIRD ANGLE PROJECTION		TITLE: HDSO-14AX PRODUCTION LIFT VER D (CE CERT)
			SIZE DWG. NO. REV A 5260584 AA
	<small> PROPRIETARY AND CONFIDENTIAL THE INFORMATION CONTAINED IN THIS DRAWING IS THE SOLE PROPERTY OF BENDPAK INC. ANY REPRODUCTION IN PART OR AS A WHOLE WITHOUT THE WRITTEN PERMISSION OF BENDPAK INC. IS PROHIBITED. </small>		SCALE: 1:40 SHEET 1 OF 3

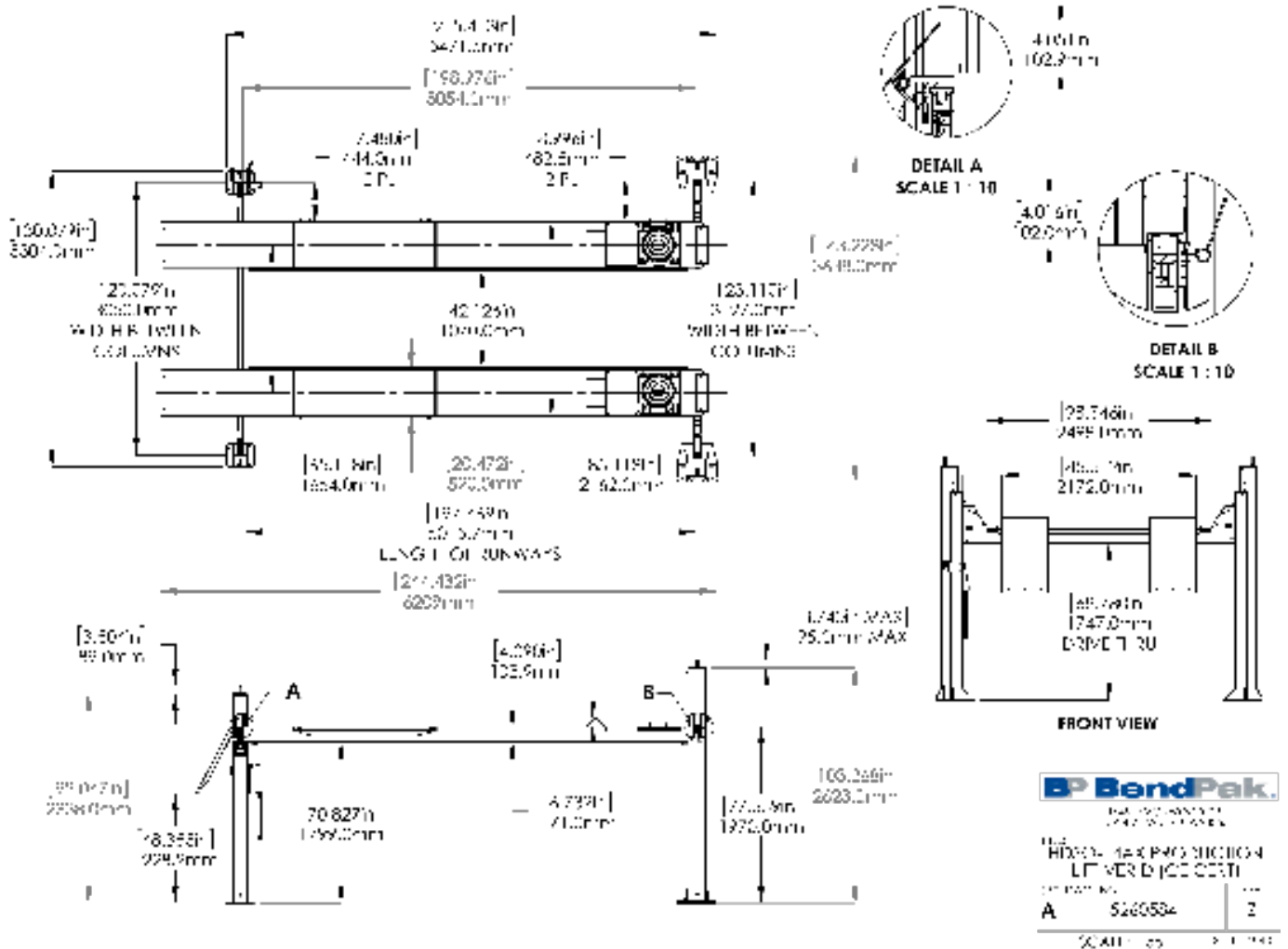

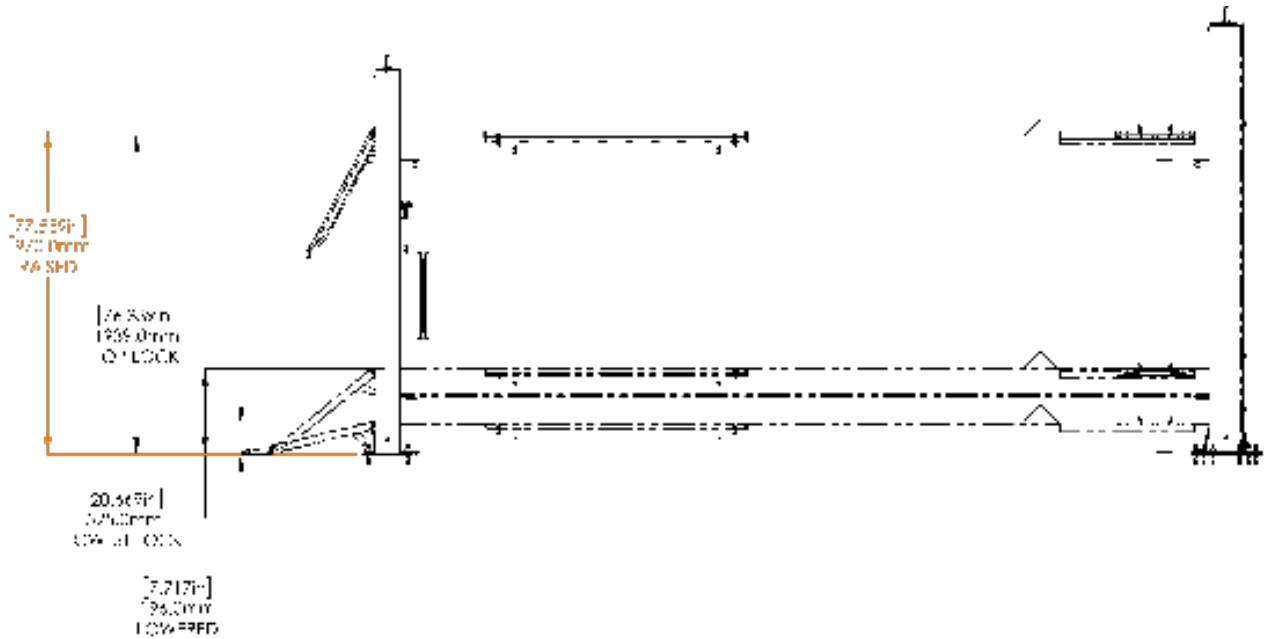

1. DIMENSIONS SHOW LARGEST CLEARANCE ASSEMBLED ALL THE WAY UP

BendPak
 1645 LEMONWOOD DR.
 SANTA PAULA, CA 93060
 TEL: 562-292-1000
 FAX: 562-292-1001
 WWW.BENDPAK.COM

THE INFORMATION CONTAINED IN THIS DRAWING IS THE SOLE PROPERTY OF BENDPAK INC. ANY REPRODUCTION IN PART OR AS A WHOLE WITHOUT THE WRITTEN PERMISSION OF BENDPAK INC. IS PROHIBITED.

REV: 02/20/2016
 A 5245416

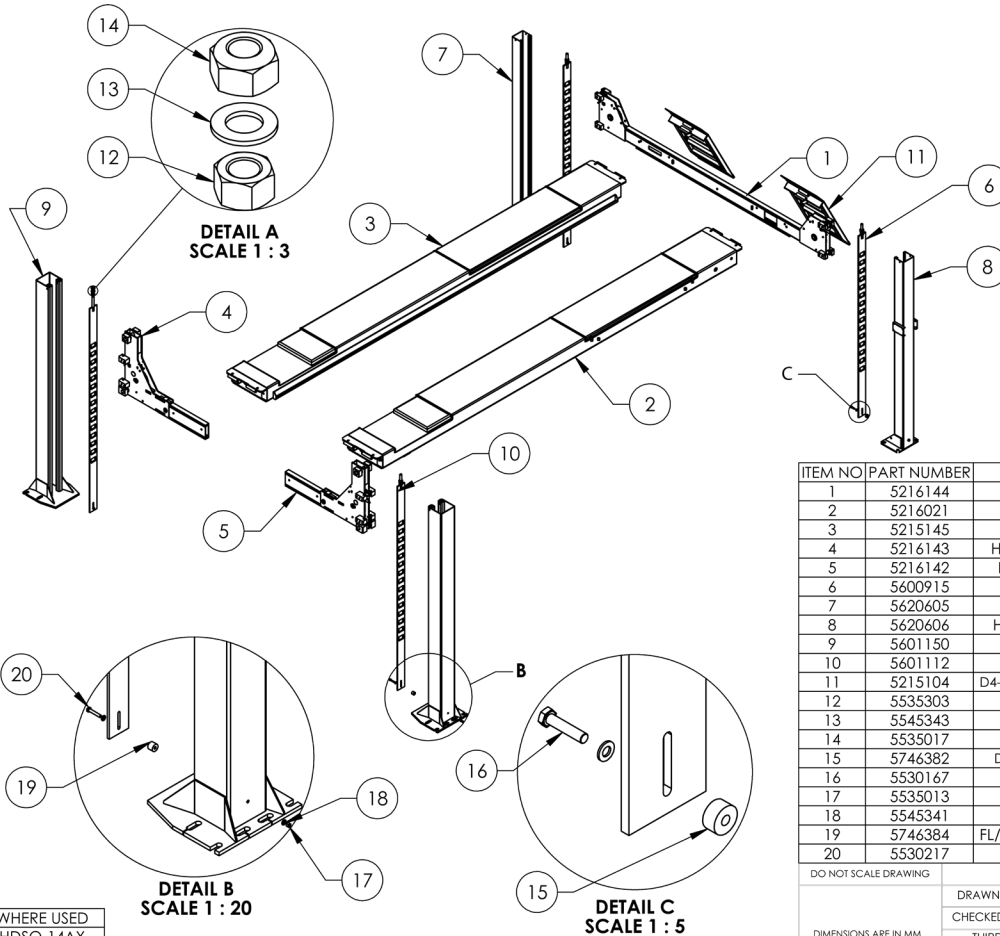

ITEM NO	PART NUMBER	DESCRIPTION	QTY	REV
1	5216144	HDSO-14 CROSSTUBE ASSEMBLY	1	A
2	5216021	HDSO-14AX POWER SIDE RAMP ASSEMBLY	1	B
3	5215145	HDSO-14AX OFF SIDE RAMP ASSEMBLY	1	T
4	5216143	HDSO-14 RIGHT FRONT CARRIAGE ASSEMBLY	1	A
5	5216142	HDSO-14 LEFT FRONT CARRIAGE ASSEMBLY	1	A
6	5600915	HDS/HDSO-14 SAFETY LADDER WELDMENT	2	B
7	5620605	HDS/HDSO-14 POST WELDMENT	1	C
8	5620606	HDS/HDSO-14 POWER SIDE POST WELDMENT	1	C
9	5601150	HDSO-14 POST WELDMENT	2	B
10	5601112	FL/HDSO-14 SAFETY LADDER WELDMENT	2	C
11	5215104	D4-12, FL/HD/HDS/HDSO-14 DRIVE UP RAMP ASSEMBLY	2	K
12	5535303	NUT M20 x 2.5	4	-
13	5545343	WASHER, M20 FLAT	4	-
14	5535017	NUT M20 x 2.5 NL	4	-
15	5746382	D4-12, HDS-14 SPACER, SAFETY LADDER, 15mm LG	2	A
16	5530167	HHB M10 x 1.5 x 45mm	2	-
17	5535013	NUT M10 x 1.5 NL	4	-
18	5545341	WASHER M10 x Ø20 FLAT	8	-
19	5746384	FL/HDS-14 SPACER, SAFETY LADDER, 23.5mm LG	2	A
20	5530217	HHB M10 x 1.5 x 58	2	-

DO NOT SCALE DRAWING

NAME: DATE: 09/23/2016

DRAWN: TM: CHECKED:

DIMENSIONS ARE IN MM

THIRD ANGLE PROJECTION

BendPak
 1645 LEMONWOOD DR.
 SANTA PAULA, CA 93060

TITLE: HDSO-14AX LIFT SUPERSTRUCTURE

SIZE: DWG. NO. 5245416 REV V

SCALE: 1:55 SHEET 1 OF 1

NOTE: UNLESS OTHERWISE SPECIFIED

- SEE SHIPPING INSTRUCTIONS FOR FINAL PACKAGING
- ASSEMBLE ITEMS AS SHOWN
- THREAD M20 HARDWARE ONTO LADDER BOLTS AS SHOWN

NEXT ASSEMBLY
5260584

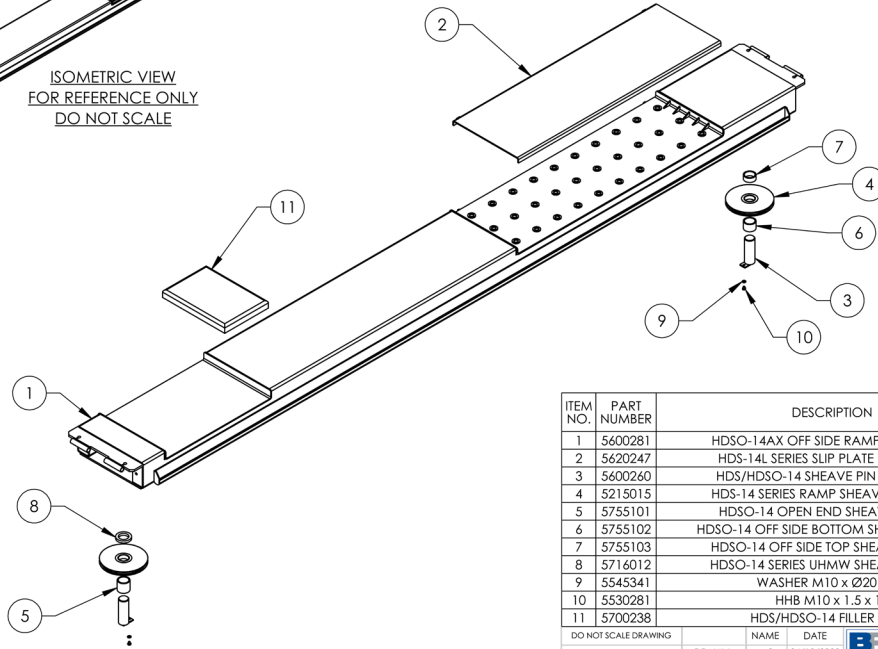
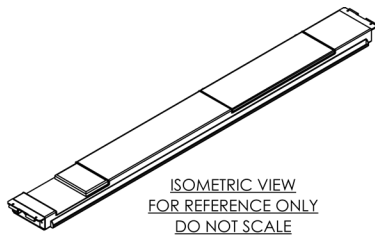

WHERE USED
HDSO-14AX

NOTE: UNLESS OTHERWISE SPECIFIED

1. REFER TO MODEL FOR ADDITIONAL INFORMATION
2. SEE SHIPPING INSTRUCTIONS FOR FINAL PACKAGING
3. ASSEMBLE ITEMS AS SHOWN

NEXT ASSEMBLY
5245416

ITEM NO.	PART NUMBER	DESCRIPTION	QTY	REV
1	5600281	HDSO-14AX OFF SIDE RAMP WELDMENT	1	L
2	5620247	HDS-14L SERIES SLIP PLATE WELDMENT	1	A
3	5600260	HDS/HDSO-14 SHEAVE PIN WELDMENT	2	C
4	5215015	HDS-14 SERIES RAMP SHEAVE ASSEMBLY	2	C
5	5755101	HDSO-14 OPEN END SHEAVE SPACER	1	B
6	5755102	HDSO-14 OFF SIDE BOTTOM SHEAVE SPACER	1	A
7	5755103	HDSO-14 OFF SIDE TOP SHEAVE SPACER	1	A
8	5714012	HDSO-14 SERIES UHMW SHEAVE SPACER	1	B
9	5545341	WASHER M10 x Ø20 FLAT	2	--
10	5530281	HHB M10 x 1.5 x 10	2	--
11	5700238	HDS/HDSO-14 FILLER PLATE	1	A

DO NOT SCALE DRAWING

DRAWN	AC	06/19/2009
CHECKED	OR	09/15/2021

NAME: **BendPak**
DATE: 1645 LEMONWOOD DR. SANTA PAULA, CA 93060

TITLE: HDSO-14AX OFF SIDE RAMP ASSEMBLY

THIRD ANGLE PROJECTION

PROPRIETARY AND CONFIDENTIAL
THE INFORMATION CONTAINED IN THIS DRAWING IS THE SOLE PROPERTY OF BENDPAK INC. ANY REPRODUCTION IN PART OR AS A WHOLE WITHOUT THE WRITTEN PERMISSION OF BENDPAK INC. IS PROHIBITED.

SCALE: 1:25

SHEET 1 OF 1

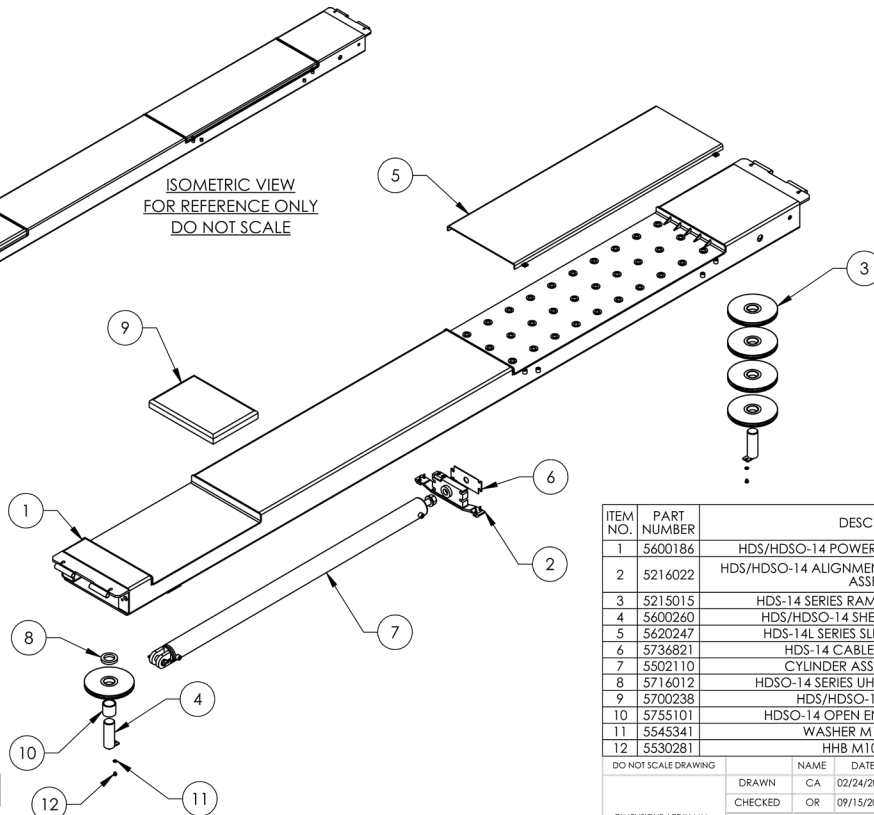
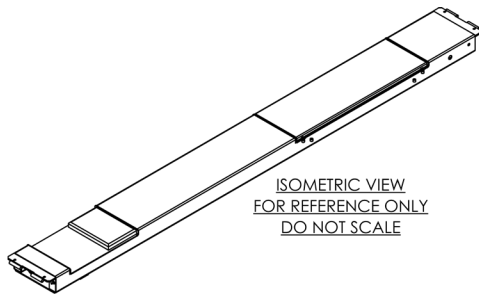

WHERE USED
HDSO-14AX

NOTE: UNLESS OTHERWISE SPECIFIED

1. REFER TO MODEL FOR ADDITIONAL INFORMATION
2. VERIFY CYLINDER PORTS AND CAPPED WITH 3/8" NPT STEEL PLUGS
3. SEE SHIPPING INSTRUCTIONS FOR FINAL PACKAGING
4. ASSEMBLE ITEMS AS SHOWN

NEXT ASSEMBLY
5245416

ITEM NO.	PART NUMBER	DESCRIPTION	QTY	REV
1	5600186	HDS/HDSO-14 POWER SIDE RAMP WELDMENT	1	J
2	5216022	HDS/HDSO-14 ALIGNMENT CYLINDER FLANGE ARM ASSEMBLY	1	A
3	5215015	HDS-14 SERIES RAMP SHEAVE ASSEMBLY	5	C
4	5600260	HDS/HDSO-14 SHEAVE PIN WELDMENT	2	C
5	5620247	HDS-14L SERIES SLIP PLATE WELDMENT	1	A
6	5736821	HDS-14 CABLE RETAINER PLATE	1	A
7	5502110	CYLINDER ASSEMBLY Ø3.5 x 70	1	K
8	5716012	HDSO-14 SERIES UHMW SHEAVE SPACER	1	B
9	5700238	HDS/HDSO-14 FILLER PLATE	1	A
10	5755101	HDSO-14 OPEN END SHEAVE SPACER	1	B
11	5545341	WASHER M10 x Ø20 FLAT	2	-
12	5530281	HHB M10 x 1.5 x 10	2	-

DO NOT SCALE DRAWING

DRAWN	CA	02/24/2021
CHECKED	OR	09/15/2021

NAME: **BendPak**
DATE: 1645 LEMONWOOD DR. SANTA PAULA, CA 93060

TITLE: HDSO-14AX POWER SIDE RAMP ASSEMBLY

THIRD ANGLE PROJECTION

PROPRIETARY AND CONFIDENTIAL
THE INFORMATION CONTAINED IN THIS DRAWING IS THE SOLE PROPERTY OF BENDPAK INC. ANY REPRODUCTION IN PART OR AS A WHOLE WITHOUT THE WRITTEN PERMISSION OF BENDPAK INC. IS PROHIBITED.

SCALE: 1:25

SHEET 1 OF 2

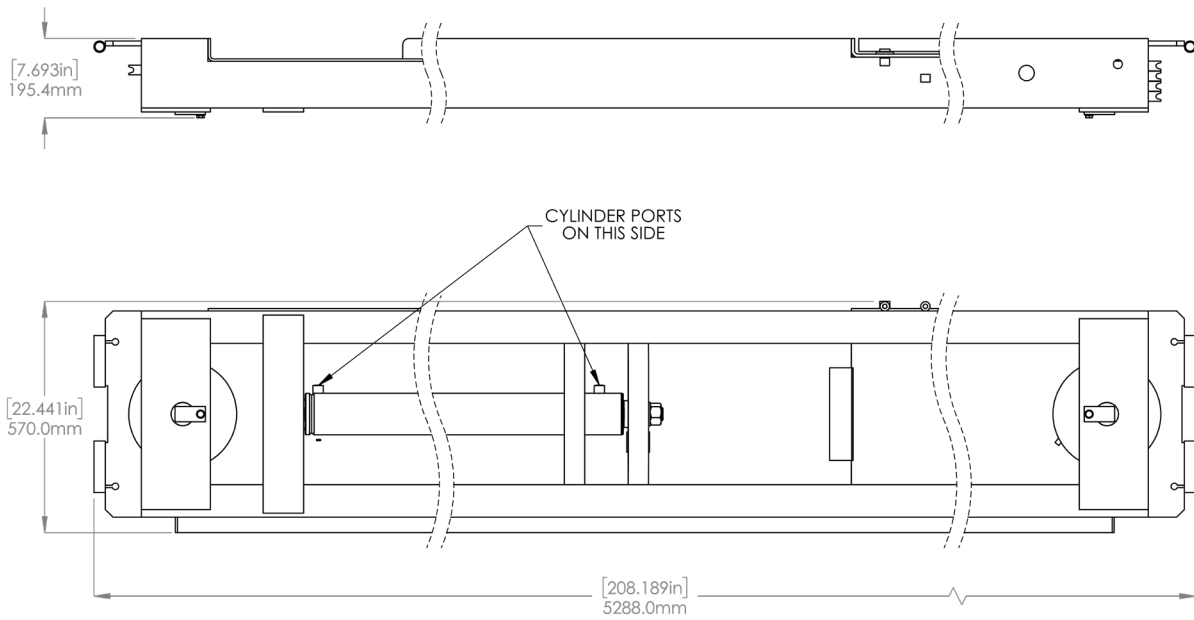

BP BendPak.
 1645 LEMONWOOD DR.
 SANTA PAULA, CA 93060

TITLE:
**HDSO-14AX POWER SIDE
 RAMP ASSEMBLY**

SIZE DWG. NO. REV
A 5216021 B

SCALE: 1:12 SHEET 2 OF 2

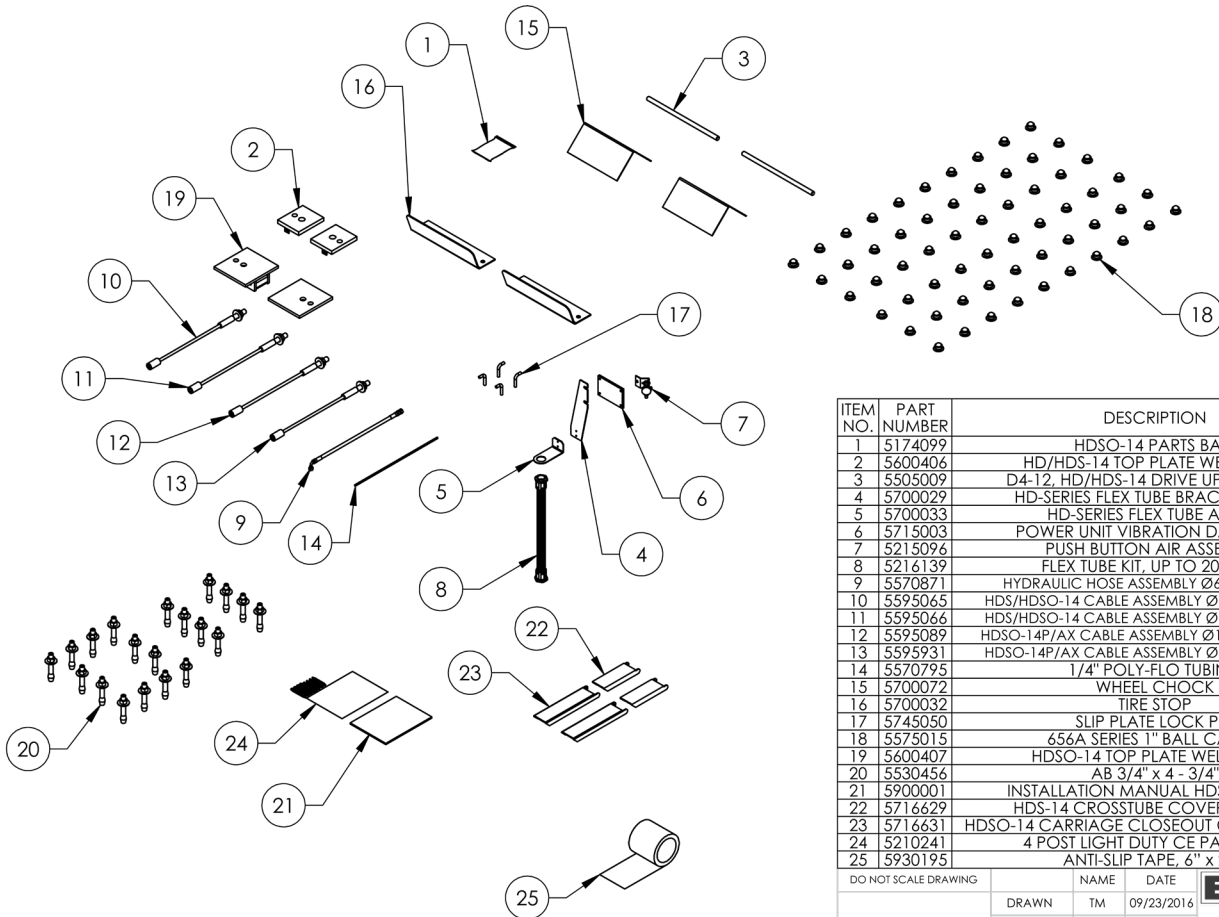

ITEM NO.	PART NUMBER	DESCRIPTION	QTY.	REV
1	5174099	HDSO-14 PARTS BAG	1	F
2	5600406	HD/HDS-14 TOP PLATE WELDMENT	2	C
3	5505009	D4-12, HD/HDS-14 DRIVE UP RAMP PIN	2	D
4	5700029	HD-SERIES FLEX TUBE BRACKET PLATE	1	F
5	5700033	HD-SERIES FLEX TUBE ANGLE	1	E
6	5715003	POWER UNIT VIBRATION DAMPENER	1	B
7	5215096	PUSH BUTTON AIR ASSEMBLY	1	G
8	5216139	FLEX TUBE KIT, UP TO 2000mm	1	A
9	5570871	HYDRAULIC HOSE ASSEMBLY Ø6.4 x 4166mm	1	B
10	5595065	HDS/HDSO-14 CABLE ASSEMBLY Ø12 x 4100mm ST	1	E
11	5595066	HDS/HDSO-14 CABLE ASSEMBLY Ø12 x 5732mm ST	1	E
12	5595089	HDSO-14P/AX CABLE ASSEMBLY Ø12 x 11302mm ST	1	D
13	5595931	HDSO-14P/AX CABLE ASSEMBLY Ø12 x 9639mm ST	1	C
14	5570795	1/4" POLY-FLO TUBING	24000mm*	-
15	5700072	WHEEL CHOCK	2	B
16	5700032	TIRE STOP	2	D
17	5745050	SLIP PLATE LOCK PIN	4	A
18	5575015	656A SERIES 1" BALL CASTER	60	-
19	5600407	HDSO-14 TOP PLATE WELDMENT	2	B
20	5530456	AB 3/4" x 4 - 3/4"	20	-
21	5900001	INSTALLATION MANUAL HDSO-14P/AX	1	-
22	5716629	HDS-14 CROSSTUBE COVER, PLASTIC	2	A
23	5716631	HDSO-14 CARRIAGE CLOSEOUT COVER, PLASTIC	2	A
24	5210241	4 POST LIGHT DUTY CE PARTS BAG	1	A
25	5930195	ANTI-SLIP TAPE, 6" x 24ft	1	B

WHERE USED
 HDSO-14AX

DO NOT SCALE DRAWING

DRAWN NAME DATE
 TM 09/23/2016

CHECKED OR 05/09/2022

DIMENSIONS ARE IN MM

THIRD ANGLE PROJECTION

BP BendPak.
 1645 LEMONWOOD DR.
 SANTA PAULA, CA 93060

TITLE:
HDSO-14AX PARTS BOX

SIZE DWG. NO. REV
A 5250059 K

SCALE: 1:25 SHEET 1 OF 1

PROPRIETARY AND CONFIDENTIAL
 THE INFORMATION CONTAINED IN THIS DRAWING IS
 THE SOLE PROPERTY OF BENDPAK INC. ANY
 REPRODUCTION IN PART OR AS A WHOLE WITHOUT
 THE WRITTEN PERMISSION OF BENDPAK INC. IS
 PROHIBITED.

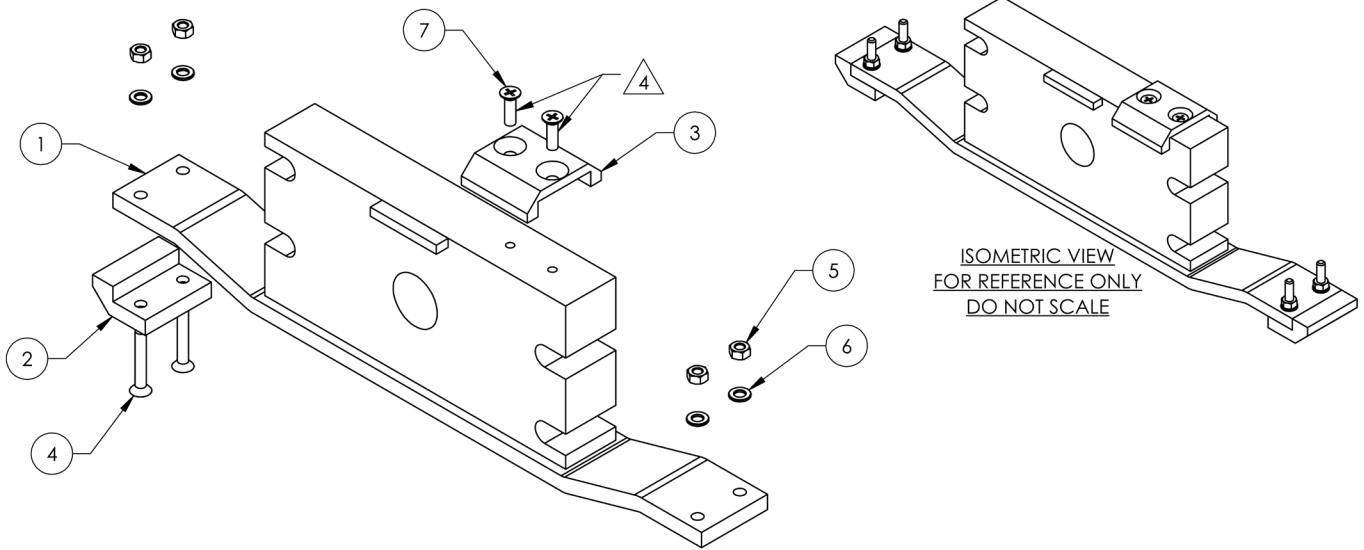

WHERE USED
HDS-14LSX
HDS-14LSXE
HDSO-14AX

NOTE: UNLESS OTHERWISE SPECIFIED

1. REFER TO MODEL FOR ADDITIONAL INFORMATION
2. SEE SHIPPING INSTRUCTIONS FOR FINAL PACKAGING
3. ASSEMBLE ITEMS AS SHOWN
4. APPLY LOCTITE (BLUE) 242 AND STAKE THREADS

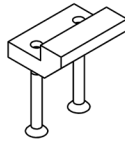

NEXT ASSEMBLY
5210261
5216019
5216020
5216021

ITEM NO	PART NUMBER	DESCRIPTION	QTY	REV
1	5601618	HDS/HDSO-14 ALIGNMENT CYLINDER FLANGE ARM WELDMENT	1	A
2	5716006	D4-12, HD/HDS/HDSO-14 CYLINDER FLANGE ARM SLIDE	2	F
3	5716176	HDS/HDSO-14LSX CYLINDER FLANGE ARM TOP SLIDE	1	B
4	5530247	FHPS M6 x 1 x 40	4	-
5	5535112	NUT M6 x 1.0	4	-
6	5545005	M6 FLAT WASHER	4	-
7	5530244	FHPS M6 x 1 x 20	2	-

DO NOT SCALE DRAWING	NAME	DATE	 1645 LEMONWOOD DR. SANTA PAULA, CA 93060
	DRAWN	TM 12/07/2012	
	CHECKED	OR 02/26/2021	TITLE: HDS/HDSO-14 ALIGNMENT CYLINDER FLANGE ARM ASSEMBLY SIZE: DWG. NO. A 5216022 REV A
DIMENSIONS ARE IN MM 			SCALE: 1:3 SHEET 1 OF 1

ISOMETRIC VIEW
FOR REFERENCE ONLY
DO NOT SCALE