

Super-Duty Four-Post Lifts

Installation and Operation Manual

Manual P/N 5900160—Revision H9 — March 2026

- Models:
- HDS-18E
 - HDS-27
 - HDS-40
 - HDS-27X
 - HDS-40X
 - HDS-40FL

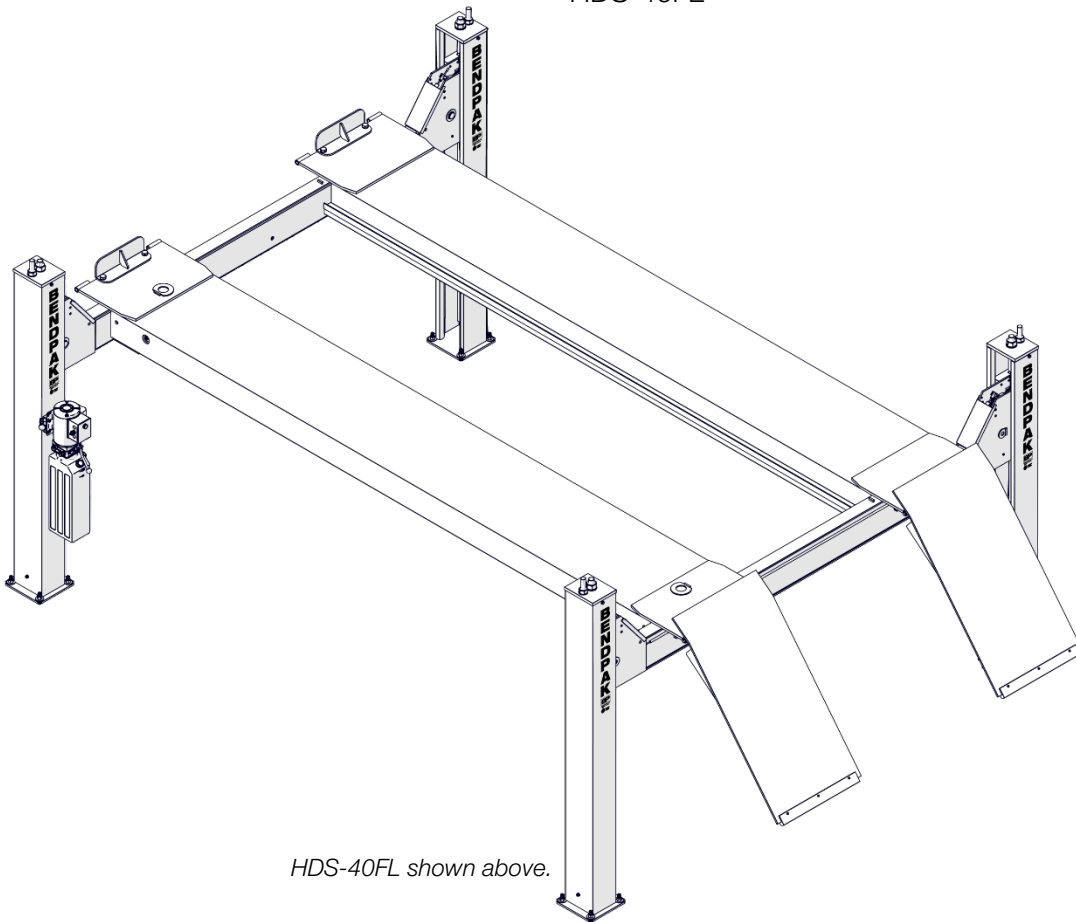

HDS-40FL shown above.

DANGER

IMPORTANT Safety Instructions, save these instructions! Read the *entire* contents of this manual *before* using this product. Failure to follow the instructions and safety precautions in this manual can result in serious injury or death. Make sure all other operators also read this manual. Keep the manual near the product for future reference. *By proceeding with installation and operation, you agree that you fully understand the contents of this manual and assume full responsibility for product use.*

Manual. HDS-18E, HDS-27/X, HDS-40/X/FL Super-Duty Four-Post Lifts, *Installation and Operation Manual*, P/N 5900160, revision H9, released March 2026.

Copyright. Copyright © 2026 by BendPak Inc. All rights reserved. You may make copies of this document if you agree that: you will give full attribution to BendPak Inc., you will not make changes to the content, you do not gain any rights to this content, and you will not use the copies for commercial purposes.

Trademarks. BendPak and the BendPak logo are registered trademarks of BendPak Inc. All other company, product, and service names are used for identification only. All trademarks and registered trademarks mentioned in this manual are the property of their respective owners.

Limitations. Every effort has been made to make sure complete and accurate instructions are included in this manual. However, product updates, revisions, and/or changes may have occurred since this manual was published. BendPak reserves the right to change any information in this manual without incurring any obligation for equipment previously or subsequently sold. BendPak is not responsible for typographical errors in this manual. Feel free to contact us at any time to get the latest information about any product: [bendpak.com](https://www.bendpak.com).

Safety. Your product was designed and manufactured with safety in mind. However, your safety also depends on proper training and thoughtful operation. Do not install, operate, maintain, or repair the unit without reading and understanding this manual and the labels on the unit; **do not use your Lift unless you can do so safely!**

Owner Responsibility. In order to ensure operator safety and maintain your product properly, it is the responsibility of the product owner to read and follow these instructions:

- Follow all setup, operation, and maintenance instructions.
- Make sure product setup and use conforms to all applicable local, state, and federal codes, rules, and regulations, such as state and federal OSHA regulations and electrical codes.
- Read and follow all safety instructions. Keep them readily available for operators.
- Make sure all operators are properly trained, know how to safely operate the unit, and are properly supervised.
- Do not operate the product until you are certain all parts are in place and operating correctly.
- Carefully inspect the product on a regular basis and perform all maintenance as specified.
- Service and maintain the unit only with approved replacement parts.
- Keep all instructions permanently with the product and make sure all labels are clean and visible. BendPak makes no promises, guarantees or assurances that our products meet any state, county, federal or international mandated permit, license, code, standard, certification, or any other mandate other than what is listed or shown on BendPak website(s), or any BendPak or Ranger online or published catalog. Not all BendPak lift models meet the standards as prescribed by ANSI/ALI ALCTV-(current edition) or ANSI/UL 201. Consult www.autolift.org for a complete list of lift models that meet ANSI/ALI ALCTV-(current edition). Buyer assumes full responsibility for any state, county, federal or international mandated permit, license, code, standard, certification, or any other mandate required related to the installation and/or operation of any BendPak or Ranger product. BENDPAK will not be responsible for any charges, fines, liens, or other levies imposed on the Buyer related to any special or regional structural, seismic or any other building code and/or codes such as the Uniform Building Code (UBC), International Building Code (IBC), or any other state, county, federal or international mandated permit, license, code, standard, certification, or other mandate, law, rule, regulation or directive by any other agency, government, administrations, or corporations whether state, county, federal, or international mandated.

Only use the Lift if it can be used safely!

Unit Information. Enter the Model Number, Serial Number, and the Date of Manufacture from the label on your unit. This information is required for part or warranty issues.

Model: _____

Serial: _____

Date of Manufacture: _____

Designed and engineered by BendPak Inc. in Southern California, USA. Made in China.

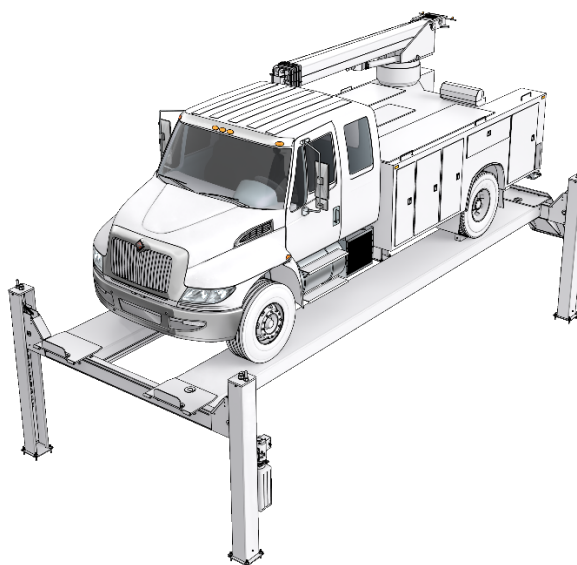
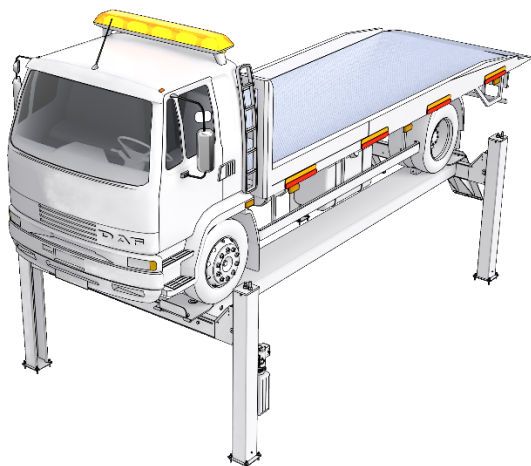
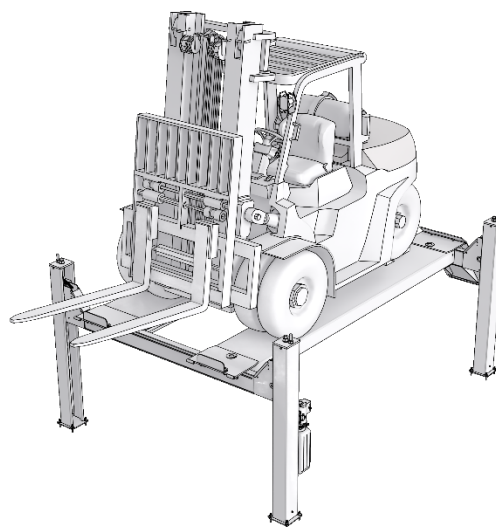
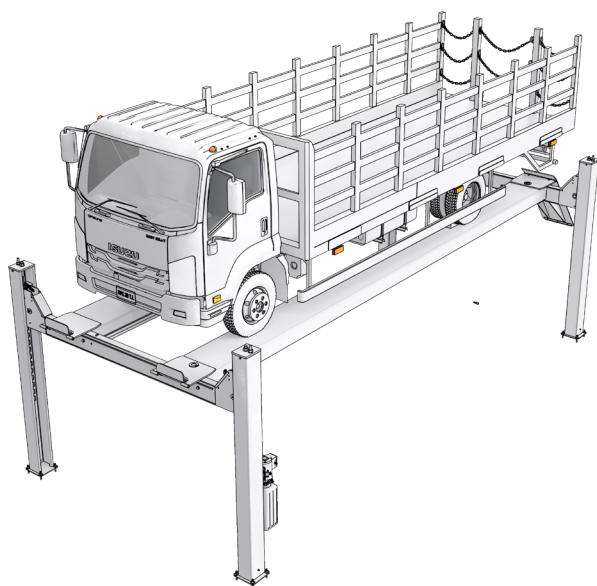

Lifts depicted as use-case examples. Do not scale

Table of Contents

Introduction	4	Installation	16
Shipping Information	5	Operation	76
Safety Considerations	6	Maintenance	81
Additional Products	8	Troubleshooting	84
Components	9	Wiring Diagrams	86
FAQs	11	Labels	87
Specifications	12	Parts Drawings	91
Installation Checklist	15	Maintenance Log	115

Introduction

This manual describes the following BendPak Super-Duty four-post Lifts: HDS-18E, HDS-27/X, HDS-40/X/FL.

- **HDS-18E** – Four-post Service Lift that can raise vehicles up to 18,000 lbs. (8,165 kg).
- **HDS-27** – Four-post service Lift that can raise vehicles up to 27,000 lbs. (12,247 kg). ALI and CE-certified.
- **HDS-27X** – Extended length four-post service Lift that can raise vehicles up to 27,000 lbs. (12,247 kg) ALI and CE-certified.
- **HDS-40** – Four-post service Lift that can raise vehicles up to 40,000 lbs. (18,144 kg). ALI and CE-certified.
- **HDS-40X** – Extended length four-post service Lift that can raise vehicles up to 40,000 lbs. (18,144 kg). ALI and CE-certified.
- **HDS-40FL** – Is a four-post service Lift intended for forklift service up to 40,000 lbs. (18,144 kg.) This Lift is not yet ALI or CE certified.

This manual is mandatory reading for all users of the HDS Super-Duty 4-Post Lifts, including anyone who installs, maintains, or repairs these Lifts.

 **DANGER** Use care when installing, operating, maintaining, or repairing this equipment; failure to do so could result in property damage, product damage, injury, or (in very rare cases) death. Make sure only authorized personnel operate this equipment. All repairs must be performed by an authorized technician. Do not make modifications to the Lift; this voids the warranty and increases the chances of injury or property damage. Make sure to read and follow the instructions in this manual and on the labels on the unit.

Shipping Information

Your equipment was carefully checked before shipping. Nevertheless, you should thoroughly inspect the shipment **before** you sign to acknowledge that you received it.

When you sign a bill of lading, it tells the carrier that the items on the invoice were received in good condition. **To protect yourself, do not sign until after you have inspected the shipment.** If any of the items listed on the bill of lading are missing or are damaged, do not accept the shipment until the carrier makes a notation on the bill of lading that lists the missing and/or damaged goods.

If you discover missing or damaged goods **after** you receive the shipment and have signed the bill of lading, notify the carrier at once and request the carrier to make an inspection. If the carrier will not make an inspection, prepare a signed statement to the effect that you have notified the carrier (on a specific date) and that the carrier has failed to comply with your request.

It is difficult to collect for loss or damage after you have given the carrier a signed bill of lading. If this happens to you, file a claim with the carrier promptly. Support your claim with copies of the bill of lading, freight bill, invoice, and photographs, if available. **Our willingness to assist in helping you process your claim does not make us responsible for collection of claims or replacement of lost or damaged materials.**

Safety Considerations

Read this entire manual carefully before using your new product. Do not install or operate the product until you are familiar with all operating instructions and warnings. Refer to ANSI/ALI ALIS Standard *Safety Requirements for Installation and Service of Automotive Lifts* for more information about safely installing your Lift.

 **WARNING** **California Proposition 65.** This product can expose you to chemicals including styrene and vinyl chloride which are on the list of over 900 chemicals identified by the State of California to cause cancer, birth defects or reproductive harm. **ALWAYS** use this product in accordance with BendPak's instructions. For more information go to www.P65Warnings.ca.gov.

IMPORTANT SAFETY INSTRUCTIONS!

Save these instructions!





1. Read all instructions.
2. Care must be taken as burns can occur from touching hot parts.
3. Do not operate equipment with a damaged cord or if the equipment has been dropped or damaged – until it has been examined by a qualified service person.
4. Do not let a cord hang over the edge of a table, bench, or counter, or come in contact with hot manifolds or moving fan blades.
5. If an extension cord is necessary, a cord with a current rating equal to or more than that of the equipment should be used. Cords with a current rating less than the equipment may overheat. Care should be taken to arrange the cord so that it will not be tripped over or pulled.

-
6. Always unplug the equipment from the electrical outlet when not in use. Never use the cord to pull the plug from the outlet. Grasp the plug and pull to disconnect.
 7. Let the equipment cool completely before putting it away. Loop cord loosely around equipment when storing.
 8. To reduce the risk of fire, do not operate in the vicinity of open containers of flammable liquids (gasoline).
 9. Adequate ventilation should be provided when working on operating internal combustion engines.
 10. Keep hair, loose clothing, fingers, and all parts of body away from moving parts.
 11. To reduce the risk of electric shock, do not use on wet surfaces or expose to rain.
 12. Use only as described in this manual. Use only BendPak recommended attachments.
 13. ALWAYS WEAR SAFETY GLASSES. Everyday eyeglasses only have impact resistant lenses, they are not safety glasses.
 14. To reduce the risk of injury, close supervision is necessary when this product is used around children.
 15. To reduce the risk of injury, **never** attempt to lift more than the rated capacity. Refer to loading instructions.
 16. The Lift uses electrical energy; if your organization has Lockout/Tagout policies, make sure to implement them after connecting the Lift to a power source.
 17. Refer to markings for proper load on electrical receptacles.
 18. Only operate your Lift between temperatures of +41°F to +104°F (+5°C to +40°C).
 19. The Lift should **only** be operated by authorized personnel. Keep children and untrained personnel away from the Lift.
 20. Do not make any modifications to the Lift; this voids the warranty and increases the chances of injury or property damage.
 21. Do not use the Lift while tired or under the influence of drugs, alcohol, or medication.
 22. Consider the work environment. Keep the work area clean. Cluttered work areas invite injuries. Keep areas well lit.
 23. **Always** make sure the Lift is secured on all four Safety Locks before attempting to work on or near a Vehicle.
 24. Make a thorough inspection of the product at least once a year. Replace any damaged or severely worn parts, decals, or warning labels. Replace worn or damaged parts with BendPak or BendPak approved parts and assemblies only.
 25. BendPak recommends referring to the ANSI/ALI ALIS Standard *Safety Requirements for Installation and Service* for more information about safely installing, using, and servicing your Lift.
 26. The HDS Series Lifts are Four-Post Service Lifts. **Use them only for their intended purpose.**
 27. You **must** wear OSHA-approved (publication 3151) personal protective equipment at all times when installing, using, maintaining, or repairing the Lift. Leather gloves, steel-toed work boots, eye protection, back belts, and hearing protection are **mandatory**.
 28. Keep loads balanced on the runways. Clear the area immediately if a Vehicle is in danger of falling off the Lift. Do not make any modifications to the Lift.
 29. Modifications void the warranty and increase the chances of injury or property damage. Do not modify any safety-related features in any way.
 30. Ensure all operators read and understand this Installation and Operation Manual. Keep the manual near the Lift at all times.

-
31. While handling a hydraulic cylinder or a Hydraulic Hose, **always** wear gloves. In rare cases, a needle-like stream of hydraulic fluid (even at low pressure) can penetrate fingers, hands, or arms; such a puncture can feel like a bite, electric shock, or a prick. While it may seem like a minor issue, any amount of hydraulic fluid injected into the human body is a serious issue. Anyone suffering such a puncture wound should be **immediately** taken to a hospital emergency room to determine the extent of the injury. Explain the circumstances of the injury to the attending physician, including what kind of hydraulic fluid was involved. Do not assume a puncture wound that could have been caused by hydraulic fluid is a minor issue; it could be life threatening.
 32. Inspect the Lift **before** using it. Check for damaged, worn, or missing parts. Do not use it if you find any of these issues. Instead, take it out of service, then contact an authorized repair facility, your dealer, or BendPak at **(877) 432-6627** or support@BendPak.com.
 33. To reduce the risk of property damage, personal injury, or loss of life, **NEVER** park any vehicle on the Lift's runways without placing suitable wheel chocks behind the rear tire so that the vehicle cannot roll backward from the Lift. Vehicles parked on Lift **MUST** also be placed in Park or First Gear (Manual Transmission) with the Parking Brake fully applied.

Symbols

Following are the symbols used in this manual:

-  **DANGER** Calls attention to an immediate hazard that **will** result in death or severe injury.
-  **DANGER** Calls attention to an immediate **electrical** hazard that **will** result in injury or death.
-  **WARNING** Calls attention to a hazard or unsafe practice that **could** result in death or severe personal injury.
-  **CAUTION** Calls attention to a hazard or unsafe practice that could result in minor personal injury, product damage, or property damage.
- NOTICE** Calls attention to a situation that, if not avoided, could result in product or property damage.
-  **Tip** Calls attention to information that can help you use your product better.

Liability Information

BendPak Inc. assumes **no** liability for damages resulting from:

- Use of the equipment for purposes other than those described in this manual.
- Modifications to the equipment without prior, written permission from BendPak.
- Injury or death caused by modifying, disabling, overriding, or removing safety features.
- Damage to the equipment from external influences.
- Incorrect operation of the equipment.

Additional Products

There are additional products available for these Lifts. Check [bendpak.com](https://www.bendpak.com) for more information:

- **Rolling Bridge Jack.** A Rolling Bridge Jack raises the wheels of a vehicle off the runways of a Four-Post Lift, making it much easier to perform service such as brake jobs and suspension work while the vehicle remains on the Lift.

You can raise two wheels off the runways if you have one Rolling Bridge Jack. It takes two Rolling Bridge Jacks to raise all four wheels off the Runways.

Refer to the [Rolling Bridge Jack page on the BendPak website](#) for more information.

- **WSA-100 Air/Electric Workstation.** The Air/Electric Workstation adds air and electric capabilities to your Lift. It includes four electrical outlets and specialized air service outlets, among other features. Refer to the [WSA-100 Air/Electric Workstation page on the BendPak website](#) for more information.

Components

The main components of your Lift include:

- **Power Post.** The post that supports the power unit. The Power Post is the only post with a mounting bracket for the power unit.
- **The Remaining Posts.** These posts are interchangeable.
- **Power Unit.** An electric/hydraulic unit that connects to an electric power source and then provides hydraulic fluid under pressure to the hydraulic cylinder that raises and lowers the runways.
- **Power Side Runway.** This runway must be installed on the same side as the power post. The power side runway includes the hydraulic cylinder and the cables running under it.
- **Off Side Runway.** The remaining runway. It does not have a hydraulic cylinder or cables under it.
- **Utility Rails.** On each runway support the optional Rolling Bridge Jacks. The Utility Rails must face each other on the inside of the Lift.
- **Crosstubes.** One at the front of the Lift, one at the rear. The Crosstubes are hollow allowing the cables that raise and lower the runways travel through. The Crosstubes are not interchangeable: the Front Crosstube has a small opening (called a ‘Window’) that faces the inside of the Lift, the Rear Crosstube has a larger Window that also faces the inside of the Lift. **Windows open to the inside of the Lift only.** Cables are routed into and out of Crosstubes through the windows.
- **Ramps.** One for each runway. An inclined ramp used to drive vehicles onto and off of the runways.
- **Tire Stops.** Located at the Front of the Lift, Tire Stops prevent the vehicle’s front tires from moving off the front of the runway. *Always chock the vehicle’s rear tires.*
- **Safety Locks.** Once engaged, they hold the runways in position, even if the power is lost or there is a leak in the Hydraulic Lines. Your Lift has 13 to 15 Safety Locks (depending on the model), spaced approximately four inches apart. This allows the Lift to be positioned at just the right height for the required work. The Lift also includes backup Slack Safety system; refer to [About Safety Locks](#) for more information. **Only leave your Lift on the ground or engaged on its Safety Locks.**
- **Pushbutton Air Valve.** A pushbutton air valve that releases the safety locks away from the ladder so that they do not engage as you lower the Lift.
- **Flex Tube Bracket.** Supports the flex tube and air valve bracket and connects to the power unit mount.
- **Ladder.** A steel component of the safety lock system installed at the back of each Lift post. Each Ladder has 13 to 15 openings depending on the model.
- **Rolling Bridge Jacks.** *An optional accessory* that raises the wheels of the vehicle on the Lift off the runway, making it much easier to perform brake and suspension work while the vehicle remains on the Lift. Refer to the [Rolling Bridge Jack page on the BendPak website](#) for more information.

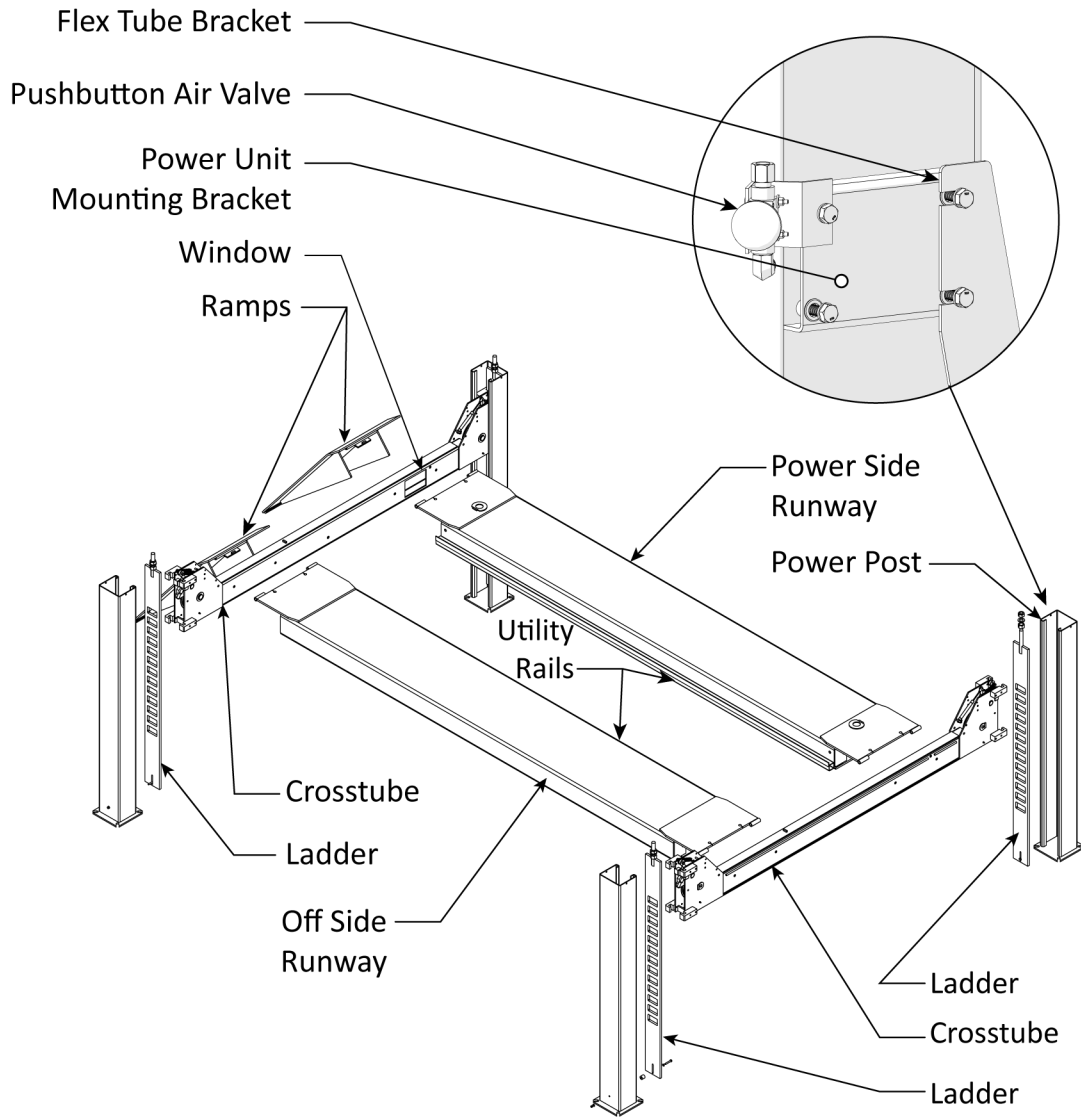

Frequently Asked Questions

Question: What kinds of vehicles can I put on my Lift?

Answer: Cars, trucks, SUVs; anything that fits on the runways, up to the rated capacity of the Lift model.

Q: How long does it take to raise or lower my Lift?

A: About 90 to 130 seconds depending on the Lift model.

Q: Does the Lift have to be anchored in place?

A: For safety, BendPak recommends anchoring the Lift.

Q: How high does the ceiling have to be?

A: It depends on the height of the vehicles placed on the runways and how high you raise the runways. If you are going to put a tall vehicle on the Lift and raise it all the way up, you should check to make sure there is enough room.

Q: Does it matter if I drive my vehicles in front first or back them in?

A: BendPak strongly recommends driving the vehicle in front first, because that makes it easier to center the vehicle's wheels on the runways. Also, remember to put the front wheels up against the Tire Stops and always chock the rear wheels.

Q: Will the lift cables really hold my vehicles?

A: Yes. All HDS Lifts use aircraft quality wire rope for the lifting cables. The HDS-18E and HDS-27 Lifts use Ø5/8 in. (16 mm) while all HDS-40 Lifts use Ø3/4 in. (19 mm) cables. All Lift cables run through oversized sheaves, reducing friction and extending the cable life with minimal maintenance.

Q: How long can I leave a vehicle on a raised runway?

A: As long as you want. Once the Lift is engaged on all four safety locks, gravity holds it in position, so a loss of power does not impact it; it is going to stay where you left it. You should always leave your Lift either fully lowered to the ground or engaged on a safety lock.

Q: Can I install my Lift outside?

A: No. Lifts are approved for indoor installation and use only. ***Outdoor installation is prohibited.***

Q: How many safety lock positions does my Lift have?

A: 13, spaced every 4 in. (102 mm).

Specifications

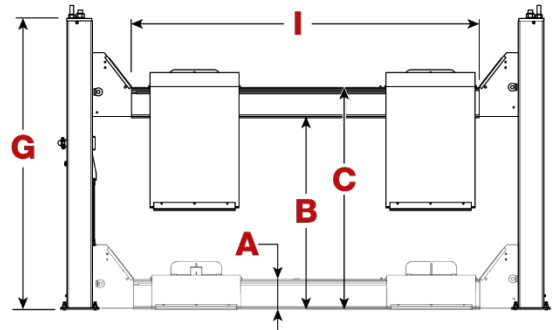
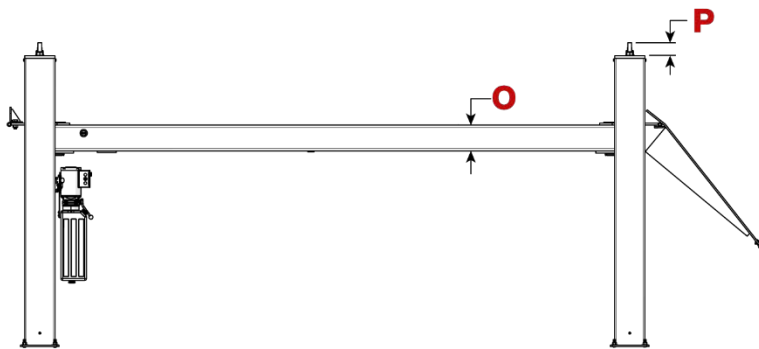
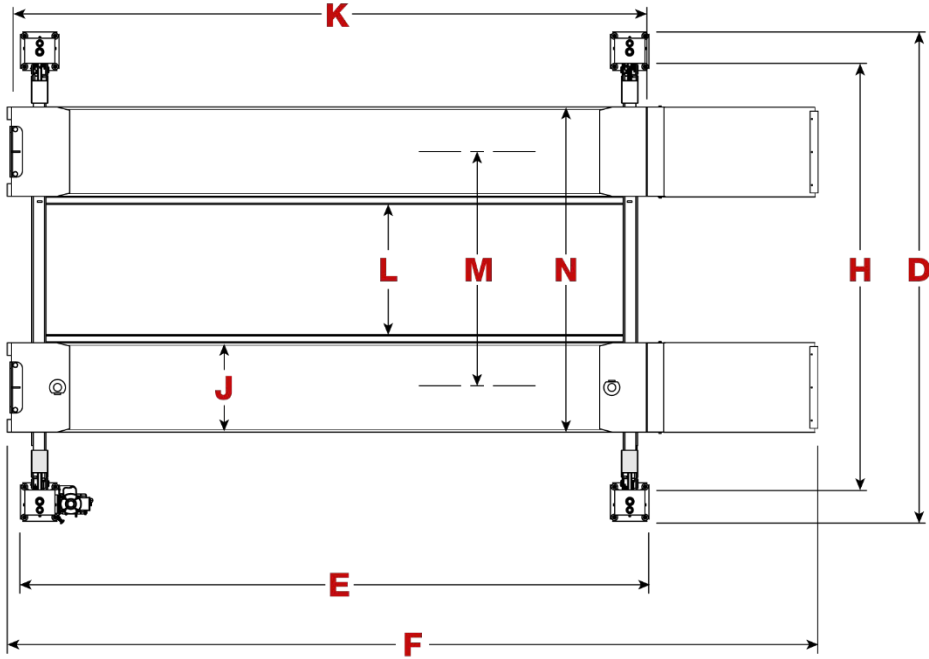

Specifications subject to change without notice.

Unless otherwise noted, all dimensions rounded to the nearest 0.25 in (6 mm). All dimensions measured with the safety lock ladder at its max. height.

Model	HDS-18E	HDS-27	HDS-27X
Lifting capacity	18,000 lbs. (18,143 kg)	27,000 lbs. (12,247 kg)	
Maximum capacity front axle	9,000 lbs. (4,082 kg)	13,500 lbs. (6,124 kg)	
Maximum capacity rear axle	9,000 lbs. (4,082 kg)	13,500 lbs. (6,124 kg)	
A Min. runway height	9.5 in. (242 mm)		
B Max. Rise	61.25 in. (1,559 mm)		
C Max. Lifting Height	69.5 in. (1,766 mm)		
D Max. Width	153.5 ±.125 in. (3,899 ±3.2 mm)		
E Outside Length	257 in. (6,528 mm)	317 in. (8,052 mm)	
F Overall Length	312.75 in. (7,943 mm)	372.75 (9,467 mm)	
G Height of Lift Post	91.25 in. (2,318 mm)		
H Width between Lift Posts	133.5 (3,391 mm)		
I Drive Thru	109 in. (2,768 mm)		
J Runway Width	22 in. (559 mm)		
K Runway Length	257.25 in. (6,537 mm)	317.25 in. (8,061 mm)	
L Width between Runways ¹	40 in. (1,016 mm) Min. 45.25 in. (1,427 mm) Max.		
M Runway Center to Center	67.25 in. (1,714 mm) Min. 72.5 in. (1,836 mm) Max.		
N Runway Outside Edge to Edge	89.25 in. (2,266 mm) Min. 94.5 in. (2,400 mm) Max.		
O Runway Height	8.25 in. (207 mm)		
P Safety Ladder Adjustment Max.	4 in. (104 mm) Max.		
Q Lowest Lock	19.75 in. (505 mm)		
R Top Lock	67 in. (1,705 mm)		
Min. wheelbase at 100% capacity ²	185 in. (4,699 mm)	185 in. (4,699 mm)	225 in. (5,715 mm)
Min. wheelbase at 75% capacity ²	155 in. (3,937 mm)	155 in. (3,937 mm)	195 in. (4,953 mm)
Min. wheelbase at 50% capacity ²	130 in. (3,302 mm)	130 in. (3,302 mm)	160 in. (4,064 mm)
Min. wheelbase at 25% capacity ²	105 in. (2,667 mm)	105 in. (2,667 mm)	130 in. (3,302 mm)
Safety Lock Positions	13, spaced every 4 in. (102 mm)		
Lifting Time to Full Rise	93 seconds		131 seconds
Electrical Power Required ³	208-230 VAC, 30.8 Amps 50/60 Hz, 1 Ph.		
Compressed Air Supply Required	30 psi at 3 cfm (2 Bar at .8 cmm) min.		

¹ May be obstructed or limited if Rolling Bridge Jacks are in use.

² The Lift's rated capacity reduces as the vehicle's wheelbase reduces. Reducing the Vehicle's wheelbase brings the rear wheels closer to the center of the runways, where there is less mechanical strength. For example, the HDS-27X max. capacity for a vehicle with a wheelbase of 100 in. is 50% or 13,500 lbs. (6,124 kg) of the Lift's rated maximum capacity.

³ Special voltages available on request.

Specifications subject to change without notice.

All dimensions rounded to the nearest 0.25 in (6 mm). All dimensions measured with the safety lock ladder at its max. height.

Model	HDS-40	HDS-40X	HDS-40FL
Lifting capacity	40,000 lbs. (18,143 kg)		
Maximum capacity front axle	20,000 lbs. (9,072 kg)		
Maximum capacity rear axle	20,000 lbs. (9,072 kg)		
A Min. runway height	9.5 in. (242 mm)		
B Max. Rise	61.25 in. (1,559 mm)		
C Max. Lifting Height	69.5 in. (1,766 mm)		
D Max. Width	153.5 ±.125 in. (3,899 ±3.2 mm)		
E Outside Length	257 in. (6,528 mm)	317 in. (8,052 mm)	197 in. (5,004 mm)
F Overall Length	313.75 in. (7,969 mm)	373.75 in. (9,493 mm)	253.75 in. (6,445 mm)
G Height of Lift Post	91.25 in. (2,318 mm)		
H Width between Lift Posts	133.5 (3,391 mm)		
I Drive Thru	109 in. (2,768 mm)		
J Runway Width	28 in. (712 mm)		
K Runway Length	257 in. (6,528 mm)	316 in. (8,026 mm)	197.25 in. (5,013 mm)
L Width between Runways ¹	40.75 in. (1,038 mm)		
M Runway Center to Center ¹	74 in. (1,880 mm)		
N Runway Outside edge to edge	102 in. (2,592 mm)		
O Runway Height	8.25 in. (207 mm)		
P Safety Ladder Adjustment Max.	4 in. (104 mm) Max.		
Q Lowest Lock	19.75 in. (505 mm)		
R Top Lock	67 in. (1,705 mm)		
Min. wheelbase at 100% capacity ²	180 in. (4,572 mm)	225 in. (5,715 mm)	140 in. (3,556 mm)
Min. wheelbase at 75% capacity ²	155 in. (3,937 mm)	190 in. (4,826 mm)	120 in. (3,048 mm)
Min. wheelbase at 50% capacity ²	130 in. (3,302 mm)	160 in. (4,064 mm)	100 in. (2,540 mm)
Min. wheelbase at 25% capacity ²	105 in. (2,667 mm)	130 in. (3,302 mm)	80 in. (2,032 mm)
Safety Lock Positions	13, spaced every 4 in. (102 mm)		
Lifting Time to Full Rise	177 seconds		
Electrical Power Required ⁴	208-230 VAC, 30.8 Amps 50/60 Hz, 1 Ph.		
Compressed air supply required min.	30 psi at 3 cfm (207 kPa at .8 cmm) min.		

¹ May be obstructed or limited if Rolling Bridge Jacks are in use.

² The Lift's rated capacity reduces as the vehicle's wheelbase reduces. Reducing the Vehicle's wheelbase brings the rear wheels closer to the center of the runways, where there is less mechanical strength. For example, the HDS-40FL max. capacity for a vehicle with a wheelbase of 100 in. (2,540 mm) is 50 percent (20,000 lbs.) of the Lift's rated maximum capacity.

⁴ Special voltages available on request.

Installation Checklist

Following are the steps needed to install your Lift. Perform them in the order shown.

- 1. Review the installation safety rules.
- 2. Make sure you have the necessary tools.
- 3. Plan for electrical work.
- 4. Site selection.
- 5. Unload and unpack the Lift components.
- 6. Create chalk line guides.
- 7. Move the posts into position.
- 8. Install the crosstubes.
- 9. Install the ladders and top caps.
- 10. Raise the crosstubes
- 11. Secure the ladders.
- 12. Install the runways.
- 13. Install the first end of the flex tube.
- 14. Read About Thread Sealants.
- 15. Install the return line.
- 16. Install the air lines.
- 17. Hydraulic Fluid Contamination.
- 18. About Thread Sealants.
- 19. Install the hydraulic hose.
- 20. Route the lift cables.
- 21. Install the power unit.
- 22. Install the second end of the flex tube.
- 23. Install the pushbutton air valve and connect the air line.
- 24. Connect the return line.
- 25. Connect the hydraulic hose.
- 26. Contact an Electrician.
- 27. Connect to a power source (**Electrician required**).
- 28. Install the power disconnect switch and thermal disconnect switch (**Electrician required**).
- 29. Anchor the posts.
- 30. Perform final leveling and cable adjustment.
- 31. Install the accessories.
- 32. Lubricate the Lift.
- 33. Bleed the hydraulic cylinder.
- 34. Perform an operational test.
- 35. Review the final checklist.
- 36. Deliver the *Installation and Operation Manual* to the owner/user/employer along with any other instructional materials furnished with the lift.

Installation

Perform the installation tasks in the order presented in this manual. **Read the entire Installation section before beginning the installation.** This will provide a better understanding of the process as a whole.

 **WARNING** **Only use the factory-supplied parts delivered with your Lift.** If you use parts from a different source, you void your warranty and compromise the safety of everyone who installs or uses the Lift. If you are missing parts, visit bendpak.com/support or call **(800) 253-2363**, follow the prompts to reach customer service.

Reviewing the Safety Rules

When installing a Lift, your safety depends on proper training and thoughtful operation. BendPak recommends referring to the ANSI/ALI ALIS Standard *Safety Requirements for Installation and Service* for more information about safely installing, using, and servicing this Lift. Review the safety information on pages 5-7 of this manual.

 **WARNING** Do not install this equipment unless you have automotive lift installation training. Do not install this equipment without reading and understanding this manual and the safety labels on the unit.

 **WARNING** Many of the Lift components are heavy and awkward to work with. Installation should be accomplished by competent personnel ensuring all heavy components are properly rigged and balanced for lifting. Installation personnel should have knowledge, training, and experience in lifting, rigging, and securing heavy objects. Always use proper lifting tools, such as a Forklift or Shop Crane, to move heavy components. Stay clear of moving parts.

 **WARNING** You **must** wear OSHA-approved (publication 3151) personal protective equipment at all times when installing, using, maintaining, or repairing the Lift: leather gloves, steel-toed boots, eye protection, back belts, and hearing protection are **mandatory**.

Tools and Supplies Required

You may need some or all of the following tools and supplies:

- Rotary hammer drill (or similar)
- 3/4 inch carbide bit (conforming to ANSI B212.15)
- Hammer and crow bar
- Four-foot level
- Open-end wrench set, SAE and metric
- Socket and ratchet set, SAE and metric
- Hex key wrench set
- Torque wrench
- Medium crescent wrench, pipe wrench
- Chalk line
- Medium-sized flat screwdriver and needle-nose pliers
- Tape measure (25 feet or above)
- Forklift, shop crane, or heavy-duty rolling dolly, and heavy-duty sawhorses
- 12-foot step ladder
- White and red lithium grease
- Hydraulic fluid, approx. 7 gallons (26.5 liters)

Planning for Electrical Work

A licensed electrician will be required to connect the Lift to power. See [Contact an Electrician](#).

NOTICE

The Electrician must provide and adequately protect the wire required to bring the facility electrical service to the Lift. Wire is not supplied with the Lift.

DANGER

All electrical work **must** be performed by a licensed Electrician. Verify all electrical work conforms to all applicable local and federal codes, rules and regulations, such as state and federal OSHA regulations and electrical codes.

Site Selection

When selecting the location and orientation of the Lift:

- **Check Clearances.**

Clearance around and above the Lift is **required for safety**. Provide adequate clearance around the lift to ensure safe operation, vehicle positioning, and service access. Surrounding equipment, walls, and structural elements should be arranged to allow free and unobstructed movement of personnel, vehicles, and service equipment such as oil drains, tool carts, and other shop apparatus through adjacent work areas and access lanes. Auxiliary and utility services should be routed so they do not interfere with lift operation or prevent removal of access covers or service panels. For proper anchor performance, position the lift no closer than 6 in. (150 mm) from any foundation expansion joint, control joint, or edge of the concrete slab. Refer to the figures below.

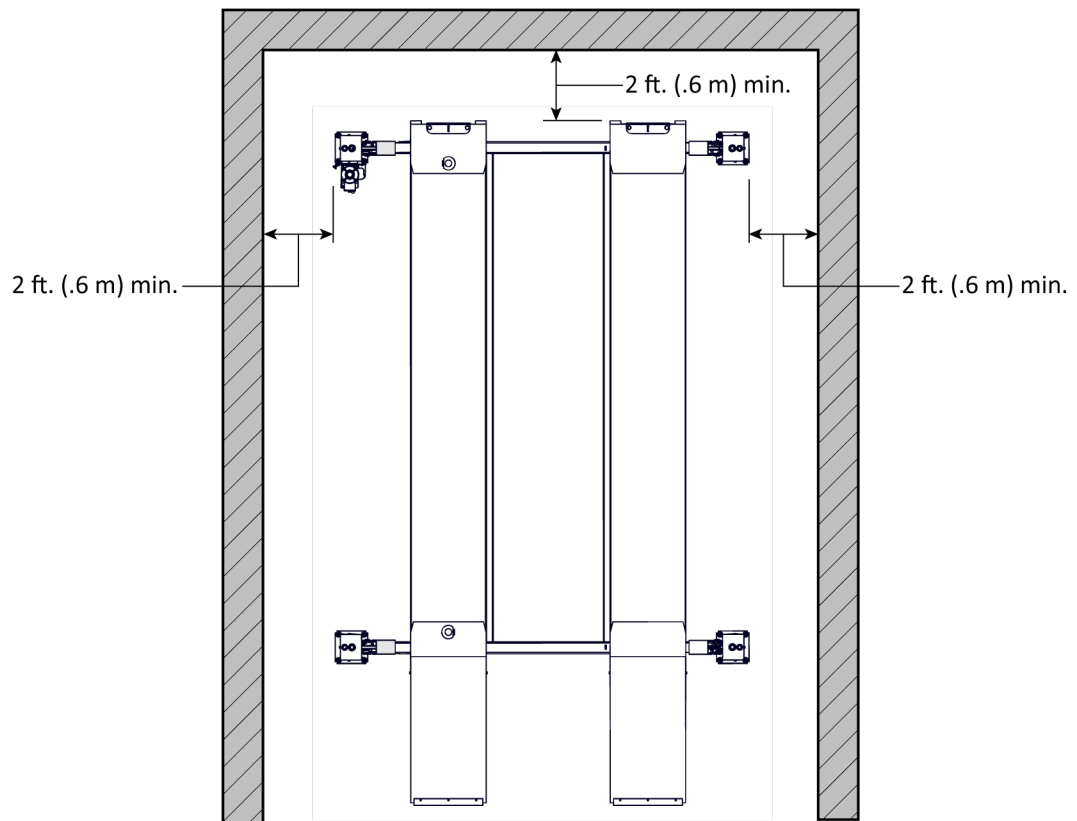

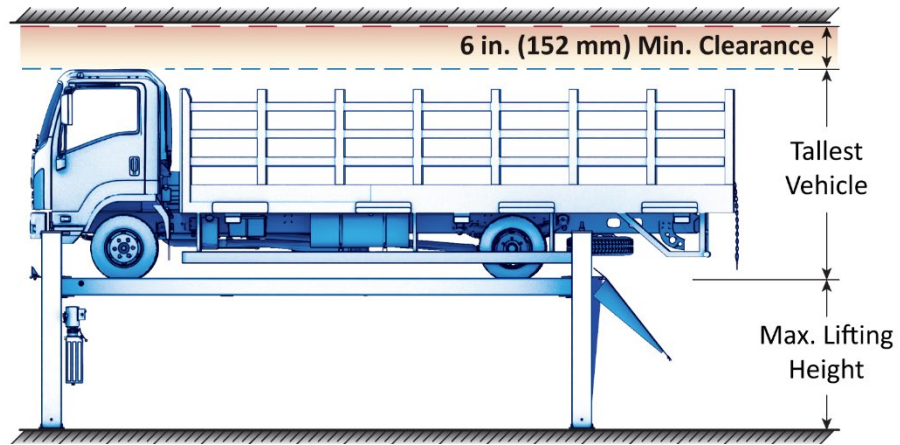

IMPORTANT! The power unit may be located at either of the locations indicated by the arrow below. It is critical that the power side runway (with hydraulic cylinder) be mounted on the same side as the power unit. Utility rails on the side of each runway must be installed facing the center of the Lift.

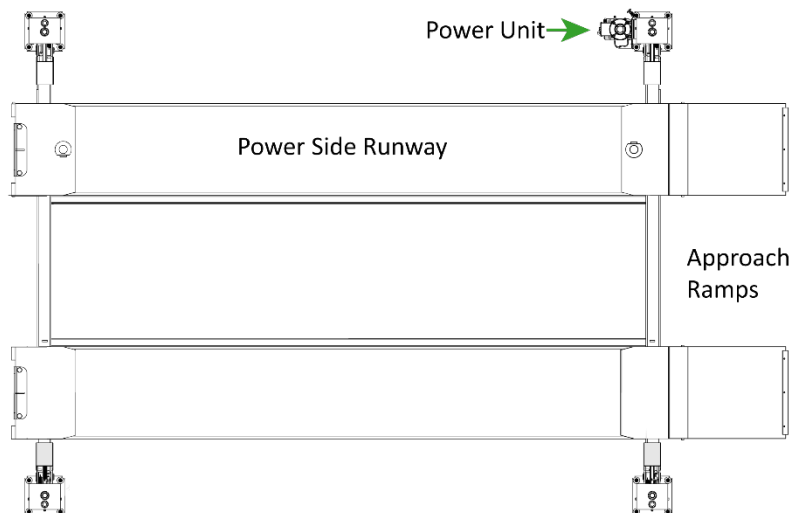
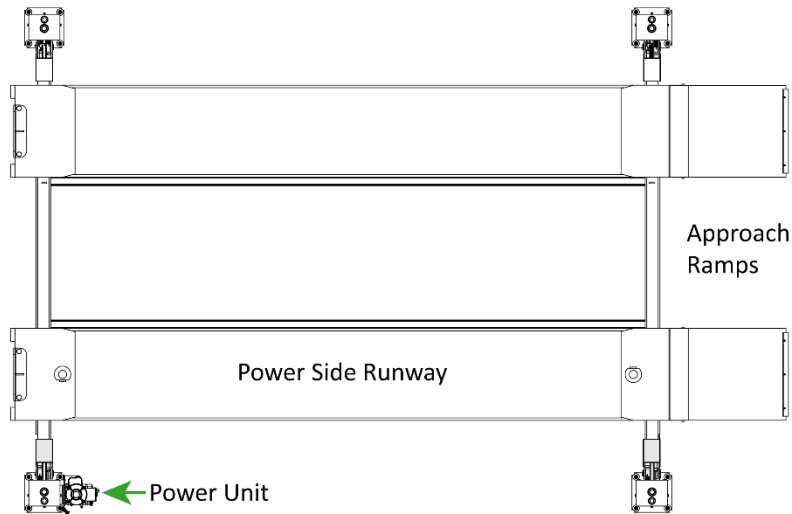

Additional Site Considerations

- **Architectural plans.** Consult the architectural plans for the desired installation site. Ensure there are no structural, plumbing, electrical or other factors preventing the installation of the Lift.
- **Outdoor installations.** Outdoor installation is prohibited. This Lift is approved for indoor installation and use only.
- **Floor.** Only install the Lift on a flat, steel reinforced, concrete floor. Do not install on asphalt or any other surface. The surface must be level; do not install if the surface has a slope equal to or greater than 3°.

⚠ DANGER Installing the Lift on a surface with more than three degrees of slope could lead to injury or even death. Only install your Lift on a level floor (defined as no more than 3/8 in. (9.5 mm) difference over the installation area). If your floor is not level, consider pouring new concrete or using a different location.

- **Shimming.** If the concrete floor is not completely level, shims are provided to be placed under the base of the posts, as required, to level the Lift. Never exceed 1/2 in. (12.7 mm) of shim height on any lift post.

To estimate the shim height requirements, use a transit level and targets to check for flatness.

NOTICE Do not shim a lift post more than 1/2 in. (12.7 mm) using the provided shims and anchor bolts. *A maximum shim of 2 in. (50.8 mm) is possible by ordering optional shim plates.* Contact BendPak at **(800) 253-2363**, then follow the prompts to reach sales. Please have the model and serial number of your Lift available.

- **Concrete specifications.** The specifications listed here are minimum requirements. BendPak strongly recommends consulting a Concrete Specialist early in the planning process for Lift installations. A concrete specialist will make adjustments to account for national, state, and local building codes/requirements as well as local weather conditions, soil composition, base preparation, load bearing, seismic requirements and any other structural concerns that may arise. Ensure the existing concrete is as presented in the table below:

Lift Model	Min. Thickness	Min. Compressive Strength/Cure	Min. Reinforcement
HDS-18	4.25 in. (108 mm)	3,000 psi/28 Days	Welded Wire Mesh
HDS-27	6.5 in. (165 mm)	3,000 psi/28 Days	Welded Wire Mesh
HDS-40	6.5 in. (165 mm)	3,000 psi/28 Days	Welded Wire Mesh

Do not install the Lift on cracked or defective concrete. Anchor Bolts must be more than 6 in. (152 mm) from cracks and expansion joints in the concrete or from a wall.

⚠ CAUTION BendPak lifts are supplied with installation instructions and concrete anchors that meet the criteria set by the American National Standard “Automotive Lifts – Safety Requirements for Construction, Testing, and Validation”, ANSI/ALI ALCTV. You are responsible for any special regional structural and/or seismic anchoring requirements specified by any other agencies and/or codes such as the Uniform Building Code (UBC) and/or International Building Code (IBC).

⚠ DANGER Check the floor to ensure it is NOT a **post-tension slab**. In this case, you must contact the building architect or the local department of building and safety before drilling. Ground penetrating radar may be of use in locating the tensioned steel.

⚠ DANGER Cutting through a tensioned cable can result in injury or death. Do not drill into a post-tension slab unless the building architect confirms drilling will **not** strike tensioned steel or it has been located using ground penetrating radar. **If a colored sheath comes up during drilling, stop immediately!**

Create Chalk Line Guides

Create Chalk Line Guides to ensure that the Posts are installed correctly.

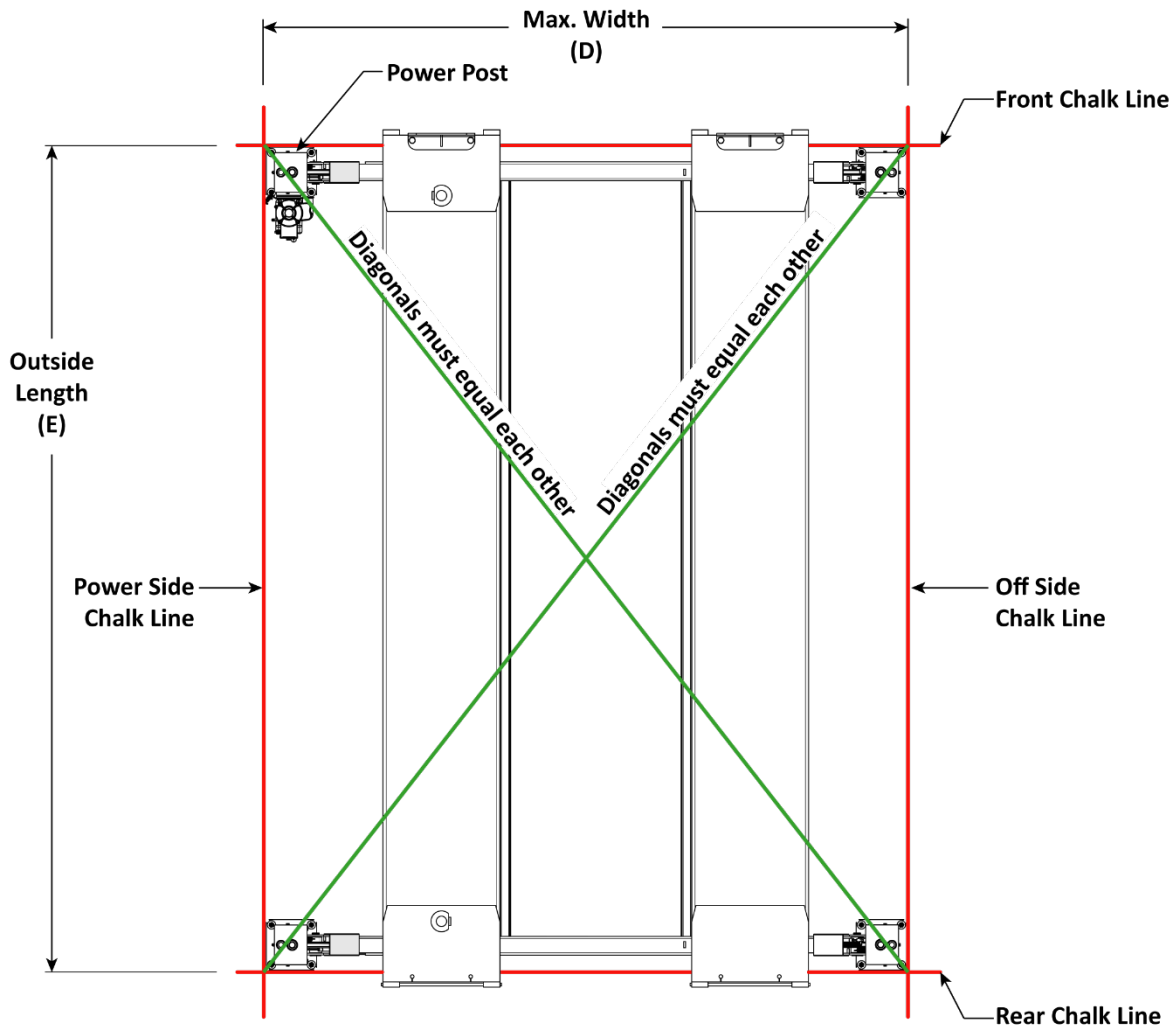

Create the Chalk Line Guides so that the outside edges of all four lift post bases fit into the four corners created by the chalk line guides.

Refer to **Specifications** to determine the **Max. Width (D)** and **Outside Post Length (E)** values for your Lift.

Note: *The Max. Width (D) dimension is to be located within $\pm .125$ in. (3.2 mm) measure carefully!*

Note: Do **not** use the Overall Length value which includes the ramps.

To create Chalk Line Guides:

1. Create a front chalk line where the front of the Lift is to be located.
Refer to the Specifications page for the Lift being installed. Make the front chalk line longer than the **Max. Width (D)** measurement for your Lift model. Reference the **Specifications** section for the dimensions on the Lift to be installed.
2. Create the power side and off side chalk lines at 90° angles to the front chalk line and parallel to each other. Make the power side and off side chalk lines longer than the **Outside Length (E)** setting for your Lift model.
The power side and off side chalk lines must be parallel to each other.
Measure to verify that this is true.
3. Create the rear chalk line parallel to the front chalk line. Make the rear chalk line longer than the **Max. Width (D)** measurement for the Lift model being installed.
The Front and Rear Chalk Lines must also be parallel to each other.
Measure to verify that this is true.
4. Before moving the Posts into position, measure **diagonally** to ensure the two diagonal measurements are the same. This will ensure the chalk lines are parallel and perpendicular.
5. Carefully drive a vehicle into the space marked by the chalk lines to ensure that the lift orientation and position will function in the site as desired.

Move the Lift Posts into Position

Use a Forklift or Shop Crane to move the lift posts. At least two people are required to stand up the posts.

 **DANGER** The lift posts are heavy and awkward. Be very careful when handling them. If they fall on a person, they will cause injury. Installation should be accomplished by competent personnel ensuring all heavy components are properly rigged and balanced for lifting. Installation personnel should have knowledge, training, and experience in lifting, rigging, and securing heavy objects. Always use proper lifting tools, such as a Forklift or Shop Crane, to move heavy components. Stay clear of moving parts.

To move the Posts into position:

1. Using a Forklift or Shop Crane, move the four Posts, one at a time, to the inside corners of the Chalk Line Guides.

Important: Position the Power Post at its **required** location. The other three Posts may be placed at any of the remaining Post locations.

2. Stand up each Post. Have at least two people work together to stand up a Post.

 **WARNING** Use caution when walking around the Posts; they are not anchored down at this point, so it is possible to knock them over, which could cause injury.

3. Use a Transit Level to estimate the Shim requirements: use a target to find the difference in height between the Posts. The difference is the estimated amount of Shim thickness you will need.

Do not use Shims and/or Anchor Bolts to Shim more than ½ in. (12.7 mm). You can order 2 in. (51 mm) shim plates for extreme cases.

4. Do **not** anchor the Posts at this point.

Install the Crosstubes

The Lift uses two crosstubes:

- The **Front Crosstube** includes a small window, located at the front of the Lift. Install the crosstube with the window facing the inside of the Lift. The small window allows two sheaves mounted on the power side runway to extend into the crosstubes and routes the lift cables to the pull block and the hydraulic cylinder.
- The **Rear Crosstube** includes a large window, located at the rear of the Lift. Install with the window facing the inside of the Lift. The large window allows four sheaves mounted on the power side runway to extend into the crosstube and routes the lift cables to the pull block and hydraulic cylinder.

The figure below displays both Crosstubes and additional components.

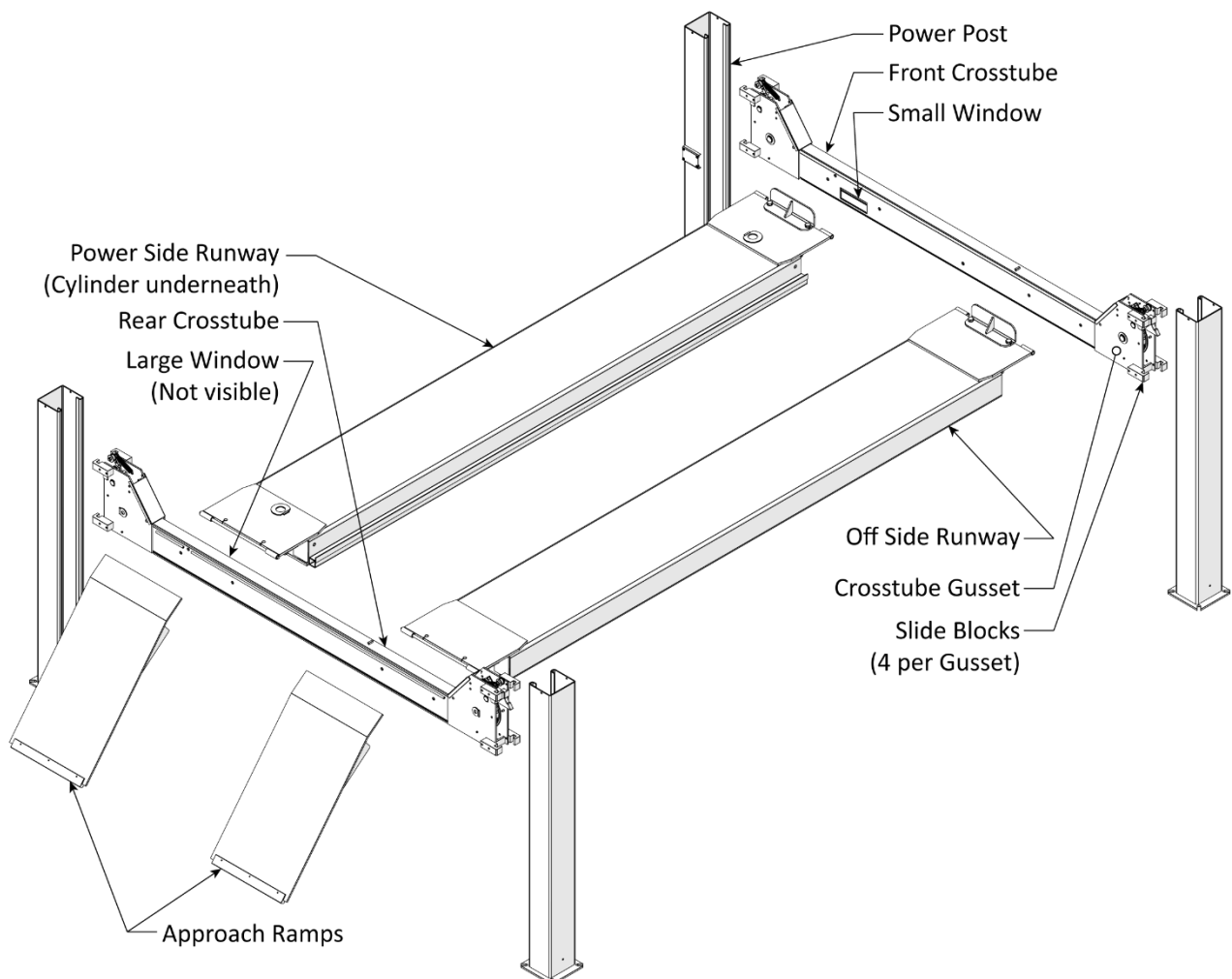

Figure not to scale. Components removed for clarity.

To install the Crosstubes:

1. Orient the crosstubes in their required locations:
 - The Front Crosstube must be at the front of the Lift with the small window facing inside.
 - The Rear Crosstube must be at the rear of the Lift with the large window facing inside.

Both windows must be on the power side of the Lift.

The Crosstubes **must** be installed in these orientations.

2. The Slide Blocks are preinstalled on the outside ends of each gusset (4 slide blocks per gusset, 8 per crosstube, 16 total for the Lift).

Verify the slide blocks are oriented so that they create a slot for the ladder when installed.

The figure below the correct Slide Block installation on a Gusset and the resulting slot formed for the Ladder.

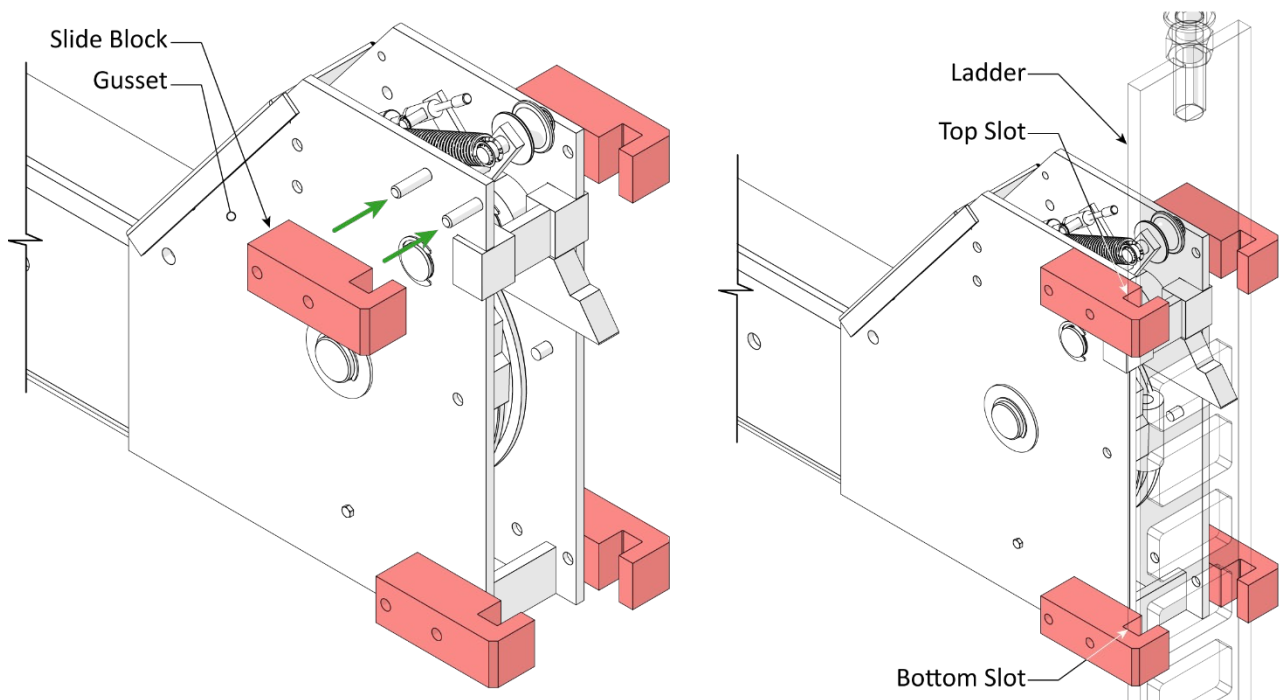

The four slide blocks on a gusset, when put into place, create two Slots about four inches wide and half an inch deep. There is one slot at the top of the gusset and a second slot at the bottom; the ladder **must** pass through **both** slots on the gusset as shown.

⚠ WARNING If the Slide Blocks are not correctly installed, then the Slots for the Ladder are not formed. In such a case, the safety locks will not function correctly, which endangers everyone who uses the Lift.

3. Using a Forklift or Shop Crane, raise the crosstube with its slide blocks installed above the top of the two lift posts, lower it to just over the top of the post, orient the slide blocks over the openings in the posts, then slide the crosstube all the way to the bottom of the lift posts.
4. Perform Steps 2 and 3 for the remaining Crosstube.

About Safety Locks

Once engaged, safety locks hold the runways in place, even if the power goes out or the hydraulic hoses break or leak. The Lift has 13 safety locks, spaced every four inches. Each post has its own safety lock mechanism.

Important: Simply raising the runway does not necessarily engage them on the safety locks. You must back the runways down onto the safety locks to engage them.

⚠ WARNING Safety Locks are dependent on correct installation of the 'Ladders'. Pay careful attention when installing the Ladders, thus ensuring correct operation of the Safety Locks on your Lift.

The Ladders, one per Post, are steel components with openings spaced every four inches. As the runways are raised, the safety locks snap into the openings in the ladder. When the runways are moved back down after passing a safety lock opening, the safety lock engages. Once engaged, safety locks will stay engaged until released to lower the runways. Even if the power goes out or one of the hydraulic lines breaks or leaks, the engaged safety locks hold the runways in place.

⚠ WARNING Always leave the runways either fully lowered or engaged on their safety locks. When the Safety Locks are engaged at the desired height, check to ensure that all four safety locks (one per Post) are engaged.

To lower the runways, they must be raised a few inches clear of the safety lock, then ***press and hold down*** the pushbutton air valve. Holding down the pushbutton releases the safety I by moving them clear of the ladders. They cannot engage while the pushbutton is held down, which allows the runways to be lowered.

Out of an abundance of caution, the Lift includes a second, independent safety lock system called the Slack Safety.

- **Safety Locks:** The primary system to hold up the runways on the Lift are the safety locks. When moving the runways up, an audible click can be heard as the safety locks snap into the ladder openings. When a desired height is reached, move the Lift runways slightly past the desired height, then back the safety locks down to rest in to the ladder openings.
- **Slack Safety:** The Slack Safeties also rely upon the ladder. They are located next to the safety locks at the ends of the Crosstube gussets. They differ from the safety locks in that when the lift cables are taut, they hold the slack safety away from the ladder so that they will not engage. However, if a lift cable breaks, the slack safety on that broken cable will immediately engage the safety ladder preventing the runways from falling.

Install the Ladders and Top Caps

Ladders must be installed on the inside rear of each post. They are secured at the top of the lift post by adjustment nuts on the top cap and at the bottom of the post by fasteners and a spacer.

Note: It is much easier to secure the bottom of the Ladders once the Crosstubes have been raised, so that portion of installing the Ladders is described in [Securing the Ladders](#).

Each ladder has 13 openings spaced four inches apart. The safety locks engage these openings.

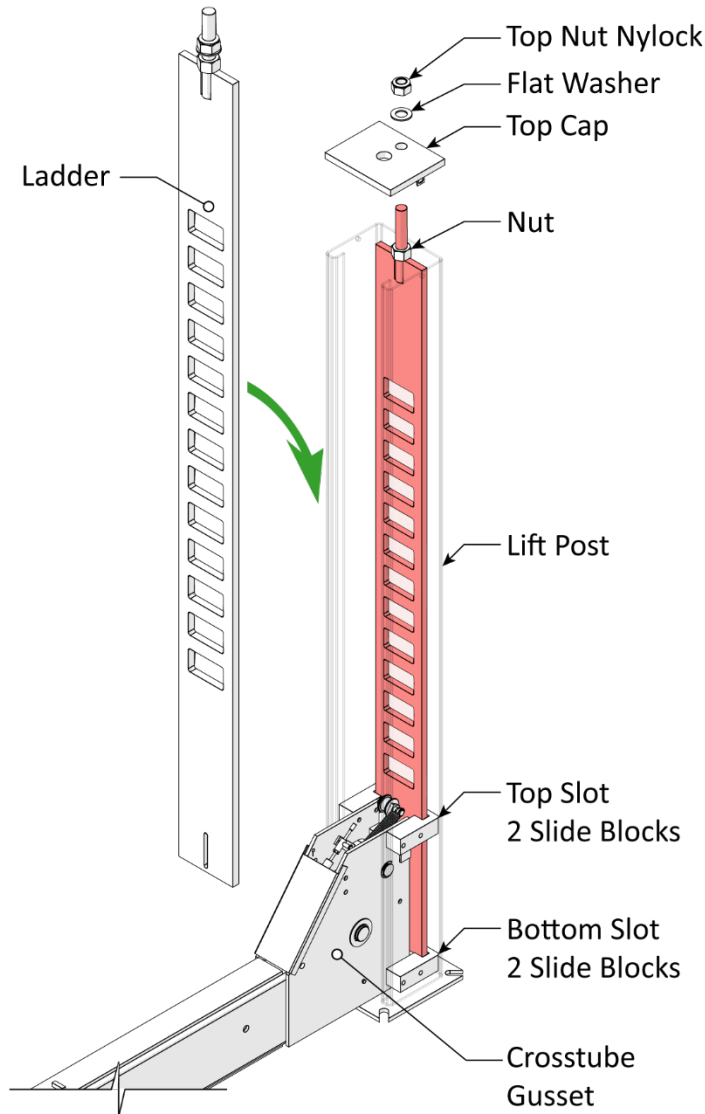

To install the ladders and top caps:

1. Place a ladder into the post with the threaded stud at the top and slide it down the back of the lift post. Refer to the figure above.

Ensure the ladder routes through both the top and bottom slots created by the slide blocks on each gusset.

If the Ladder misses a slot or the slide blocks are not installed correctly, the safety locks will ***not*** function correctly.

⚠ DANGER Ensure all four ladders are installed correctly. If not, the safety locks will not hold the weight of a vehicle, putting anyone under the Lift in danger. If the vehicle were to fall, it could cause significant injury to anyone underneath it.

2. On each ladder, install a stop nut on the threaded stud at the top. Position this nut about half of the way down towards the top of the Ladder.

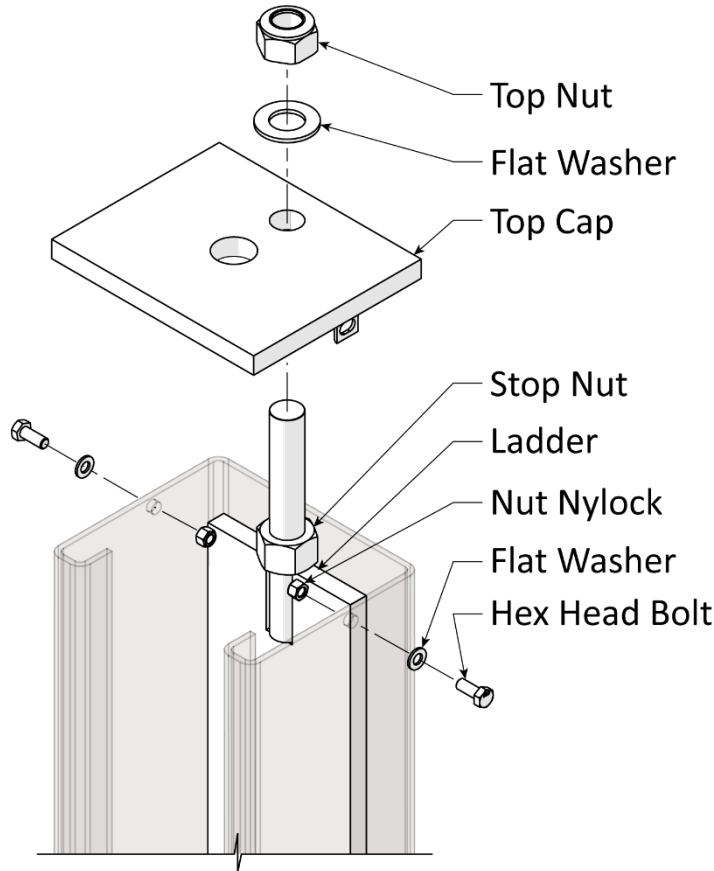

3. Place a top cap onto the top of the post, securing it on the sides with hex head bolts and nyloc nuts as shown above.
4. Once the top cap is secure, move the stop nut up until it contacts the underside of the top cap.
5. Add a flat washer and nyloc top nut on top of the top cap and hand tighten. Adjust the nuts until about 1 in. (25 mm) of thread is above the top nut.

Note: The other opening in the top cap is for the lift cable that is routed to the top of the post, which will be added later in the installation.

6. Install the other three top caps on their posts in the same manner.

Raise the Crosstubes

The crosstubes must be manually raised to the same height to complete the rest of the installation.

To raise the Crosstubes:

1. Using a Forklift or Shop Crane, carefully raise each crosstube.

Raise both Crosstubes to the same height. At least 24 in. (610 mm) off the ground. Many installers move them high enough to work under comfortably. Upcoming tasks include routing lift cables, return line, air lines, and hydraulic hoses which will require access to the underside of the runways.

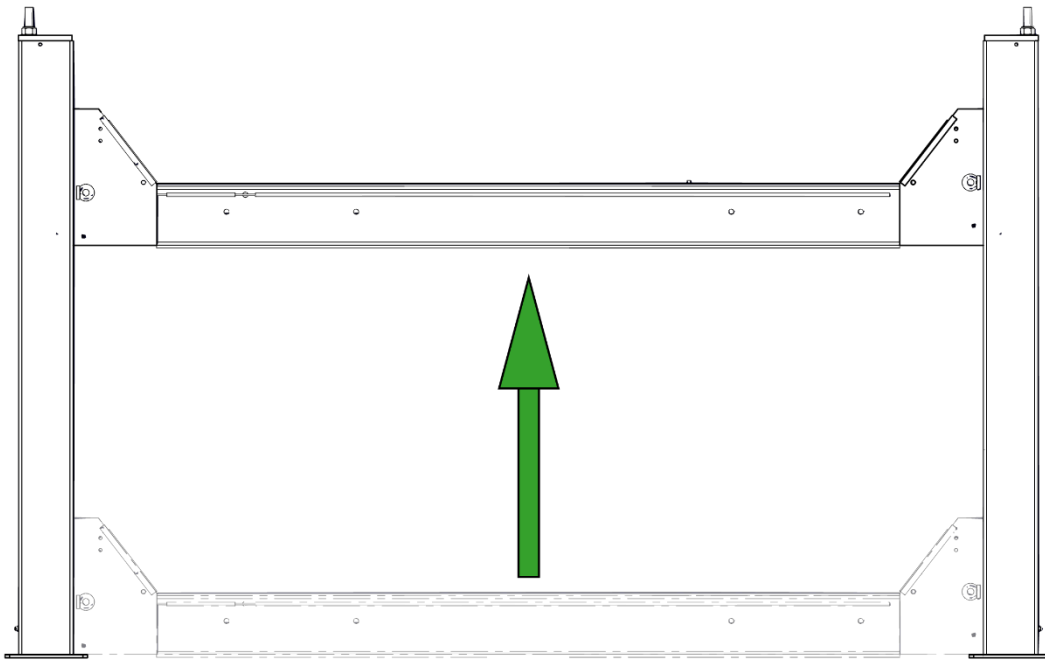

The Slack Safeties cannot be engaged while continuing with the installation. Because the cables are not installed, the slack safeties will engage when the Crosstubes are manually raised. They must be disengaged after raising the Crosstubes. The Primary Safeties are not impacted; they will engage normally when each Crosstube is manually raised.

To disengage the Slack Safeties after raising a Crosstube:

1. Raise and hold one end of the crosstube about an inch off its lock so the primary and slack safety locks are disengaged.
2. Push and hold the sheave or the steel mounting arm in toward the ladder and the back of the post (this moves the slack safety lock so it cannot engage), lower the end of the crosstube, then release the Sheave.
3. Disengage the other three slack safety locks as done in steps 1 and 2.
4. Once both Crosstubes are in position, **all four Primary Safeties are engaged**, and all four slack safeties have been **disengaged**, the installation can continue.

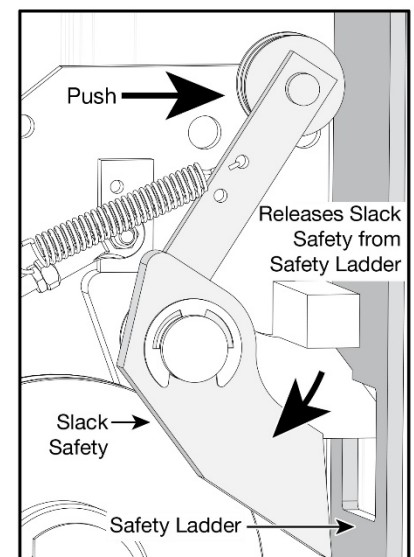

Secure the Ladders

It is much easier to secure the ladders at the bottom of each post **after** the crosstubes have been raised.

Note: The following procedure assumes that the Ladders are in place and secured at the top. If this is not the case, return to **Installing the Ladders**.

To secure the Ladders:

1. Locate the bolt, washer, spacer, second washer, and nut.

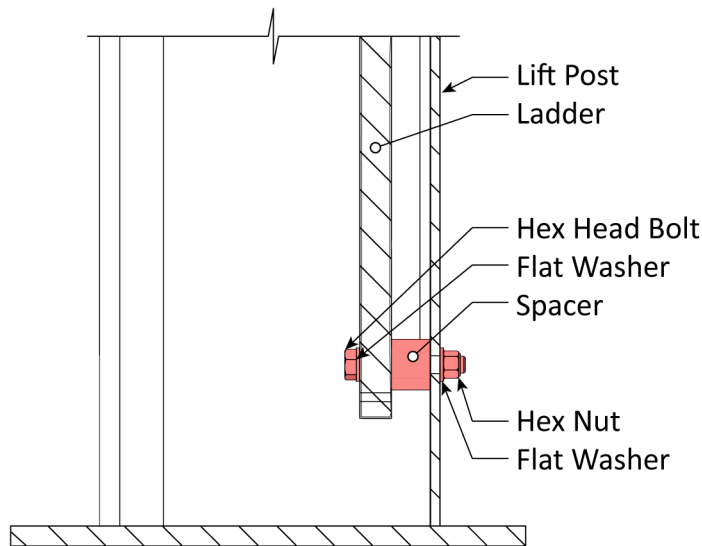

Cross Section View

2. Assemble the bolt, washers, spacer, and nut centered in the slot at the bottom of the ladder as depicted in the cross section view above.
3. Repeat the procedure to secure the other three ladders on the Lift.

Note: Do not securely tighten the top nut on the top cap at this point. The top nut and the stop nut will be used later to adjust level of the Lift's runways. They will be securely tightened after completing the final leveling of the Lift. Refer to **Final Leveling** for additional information.

⚠ DANGER Ensure that all four ladders are correctly installed and secured. If not, the Lift may not be able to hold a vehicle, which is a danger to anyone under the vehicle or around it.

Install the Runways

⚠ DANGER Pay close attention when moving the runways into position. Runways are heavy, long, and could shift position or fall, potentially causing serious injury.

To install the runways:

1. Use a forklift or shop crane to raise the power side runway or place it across sturdy and stable work stands to provide access to the underside.
2. On the power side runway, remove all cable sheaves.

To remove the cable sheaves: remove the hair pin securing the sheave shaft pin, pull out the sheave pin, then remove the cable sheaves and spacers. Refer to the figure below.

There are four cable sheaves at the rear of the Lift and two cable sheaves at the front of the Lift.

Note: The sheave spacers are to be installed between sheaves. The ramp sheave spacers are to be installed between the ramp weldment and the sheave spacer.

Note: Keep all of the components nearby, they will be reinstalled shortly.

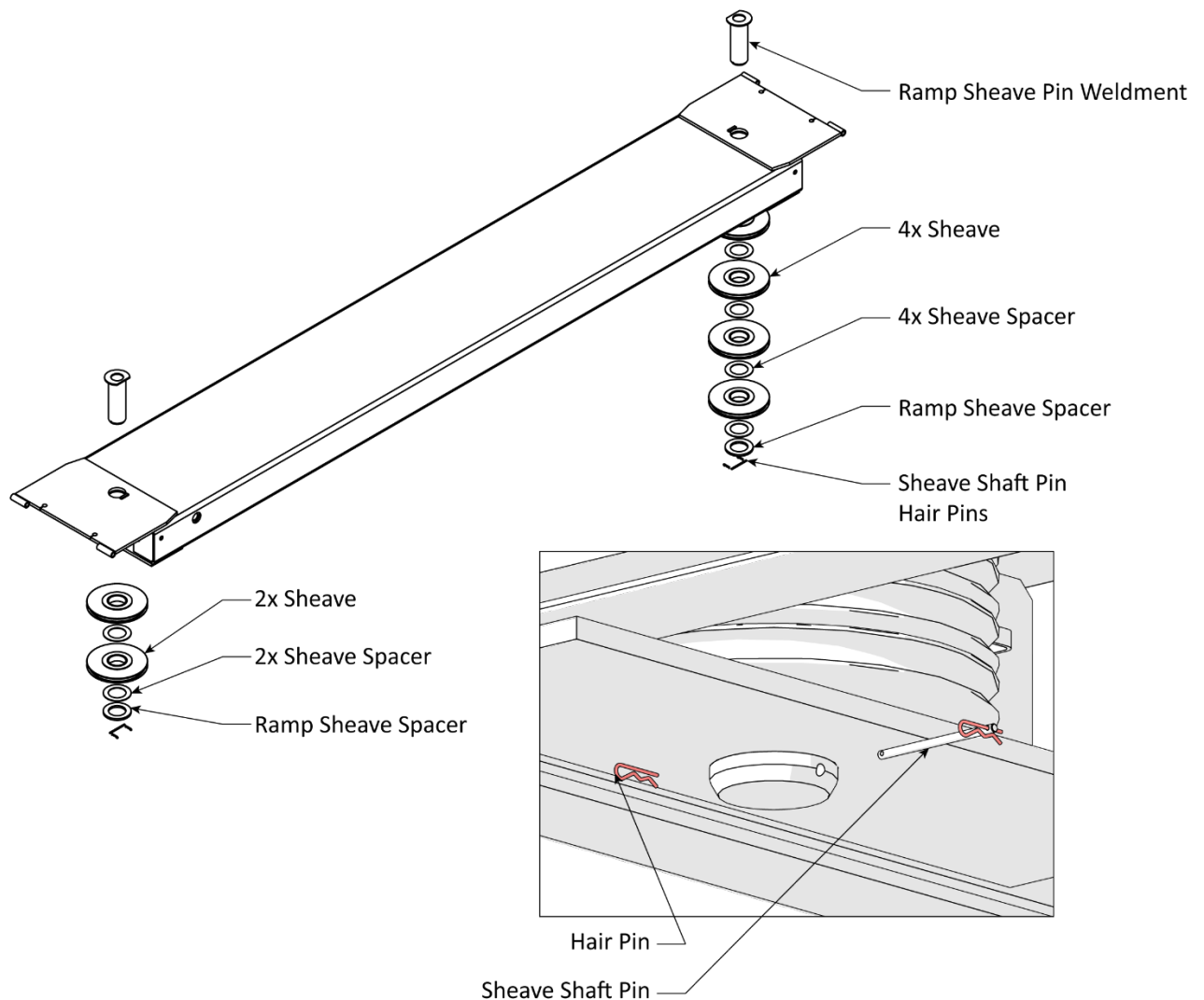

- After removing the cable sheaves, use a forklift, hoist or shop crane to pick up the power side runway and move it into place on the power side of the Lift.

Ensure the utility rail faces the inside of the Lift. Refer to the figure below.

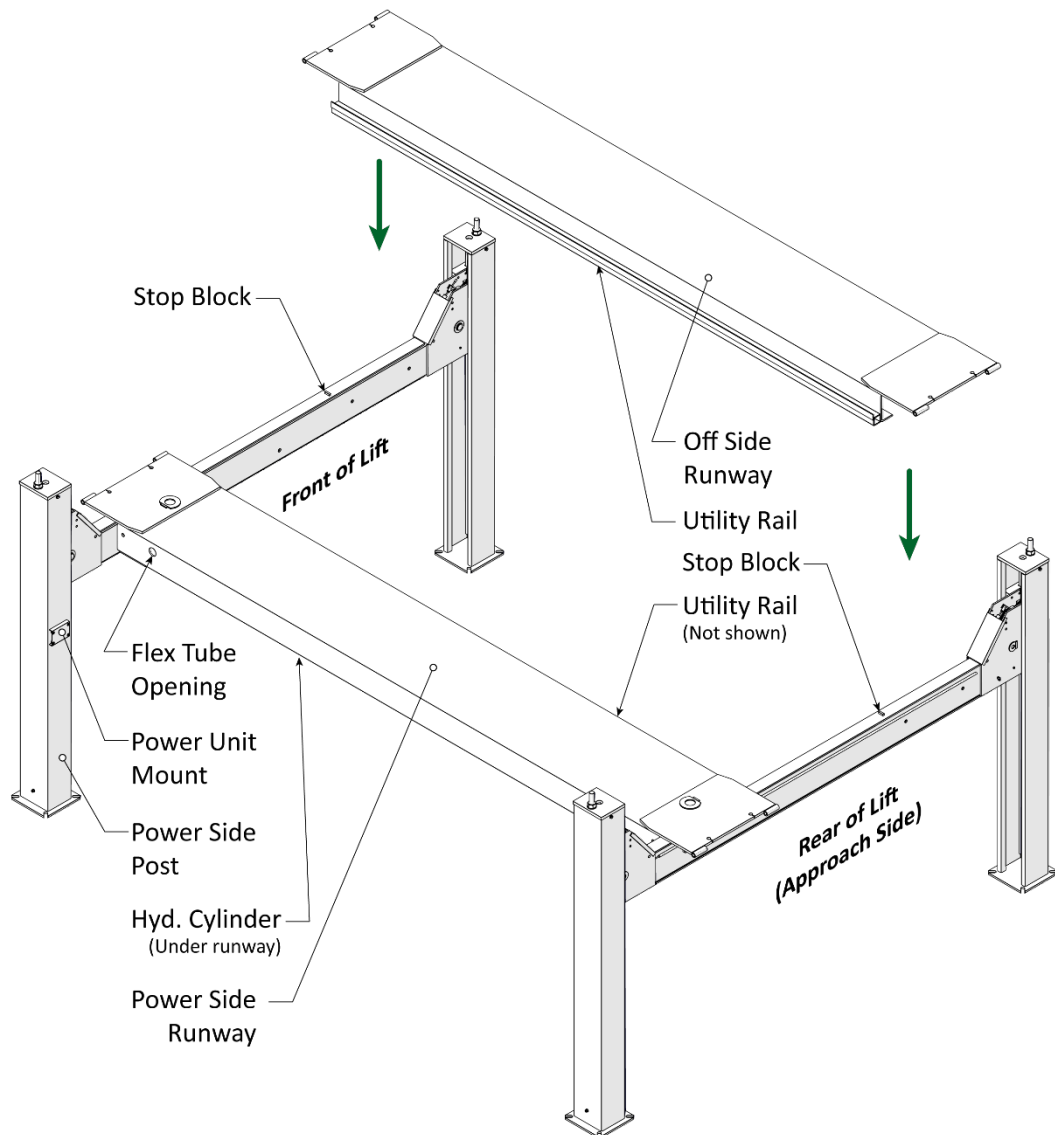

- Bolt the power side runway into place, two Bolts on each end passing through the Crosstubes. Use four M18 x 2.5 x 150 hex head bolts, M18 split ring lock washers, M18 flat washers, and M18 hex nuts.
- Using a forklift or shop crane, pick up the off side runway and move it into place between the stop blocks.

Ensure the utility rail faces the inside of the Lift

The off side runway does not include cable sheaves, nor does it require bolting into place at the moment.

- Ensure all four safety locks are engaged on the crosstubes.

⚠ DANGER

Do not continue with the installation until you have visually confirmed that all four safety locks are engaged. If they are not engaged, the runways could move or fall, possibly causing personal injury or product damage.

Install the Flex Tube

The Flex Tube consolidates and protects three different cables that route from the power side runway and terminate to the power unit or the pushbutton air valve.

The flex tube is a flexible, black tube that attaches to an opening on the power side runway on one end and to the bottom of the flex tube bracket plate (near the power unit) on the other end.

The supplied flex tube is much longer than required and must be cut to size. The flex tube supplied is approximately 82 in. (2,100 mm) long and is about 1.5 in. (38 mm) in diameter.

The tube will contain:

- **Return Line.** A thin, black tube that returns excess hydraulic fluid to the fluid reservoir on the power unit.
- **Air Line.** A thin, black tube that routes air pressure used to disengage the safety locks so that the runways may be lowered.
- **Hydraulic Hose.** A heavy, black hose that routes hydraulic fluid from the power unit to the hydraulic cylinder.

Installation of the Flex Tube is generally accomplished in two separate steps. The first step is accomplished now and the second step after the power unit and the flex tube bracket plate are installed.

The figure below shows the flex tube and connectors.

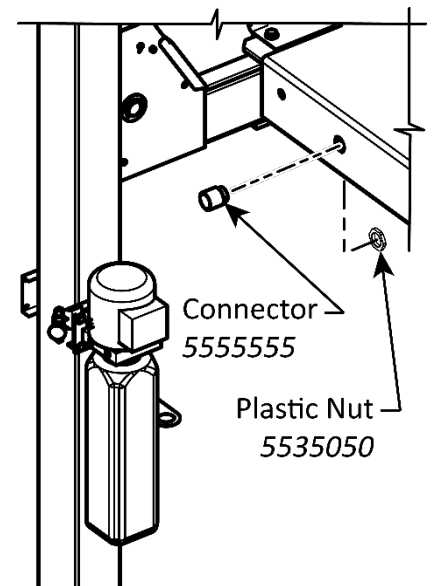
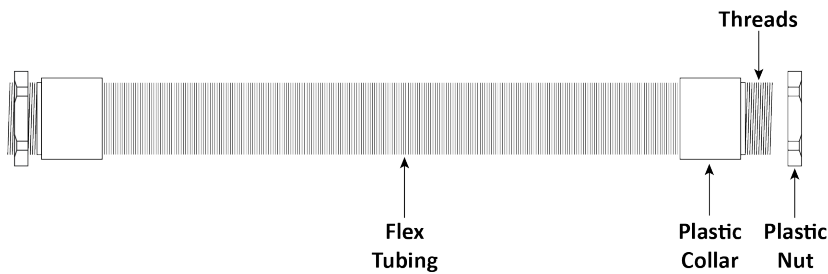

To install the Flex Tube on the Power Side Runway:

1. Unscrew the plastic nut from one end of the flex tube.
2. Holding the flex tube by the plastic connector, put the threaded end through the opening in the power side runway.
3. Inside the power side runway, screw the plastic nut back onto the threads of the plastic connector and tighten.
4. Let the other end of the flex tube hang in place until the flex tube bracket plate is installed.

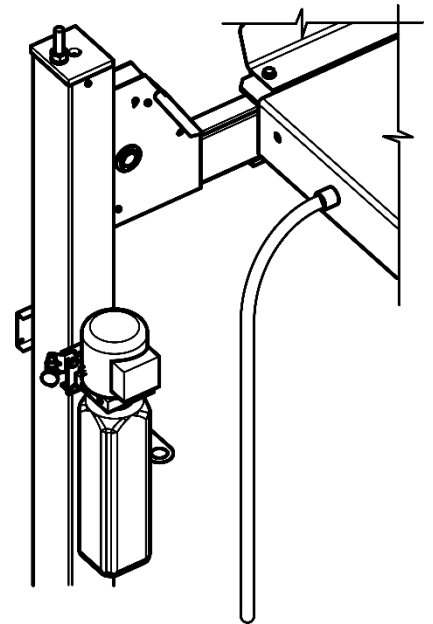

Working with Compression Fittings and Tubing

The Lift is delivered with a roll of 1/4 in. (6 mm), black, polyethylene tubing (also called Poly-Flo® Tubing) that is used with compression fittings on the return line and the air lines.

Important: While both lines use tubing and compression fittings, the return line and air lines are used for completely separate purposes; do not connect the two together.

Note: Compression fittings are different from hydraulic fittings. This section covers compression fittings only.

The components involved with compression fittings include:

- **1/4 inch, black, polyethylene tubing.** You use a single piece of tubing for the return line. The air lines require multiple tubing pieces. Create the tubing pieces for both the return line and the air lines by cutting lengths from the long roll of tubing supplied with your Lift.
- **Elbow Compression Fittings.** The return line uses two elbow compression fittings, one at each end.
- **Tee Compression Fittings.** The air lines require three tee compression fittings.
- **Nuts, Ferrules, Rods, and Threads.** Each connector on elbow and tee compression fittings has a nut, ferrule, rod, and threads (see drawing below). The nut holds the tubing and fitting together. The ferrule compresses when you tighten the nut on the threads to make a secure connection. The rod goes inside the tubing so that nothing leaks out.

The following drawing shows the components of a connector on a tee compression fitting.



Important: *Ferrules can only be tightened once.* When you tighten the nut on the threads, the ferrule gets compressed; it literally changes shape and **cannot** be used again.

To connect tubing to a compression fitting:

1. Push the tubing through the nut and over the rod.
Do not push hard; you only need the tubing to go a little way over the rod. You cannot see the ferrule at this point, but the tubing must go through the ferrule and over the rod.
2. Slide the nut on the tubing **away from the Fitting**, if the nut is still on the threads, unscrew it from the threads and then slide it away from the fitting. See the drawing above.
3. Slide the ferrule over the tubing, away from the fitting and towards the nut.
4. With the nut and the ferrule out of the way, push the tubing further over the rod until it stops.
5. Slide the ferrule and the nut back to the threads on the fitting.
The ferrule goes around the rod and under the threads. The nut goes onto the threads.
6. Tighten the nut.

Remember that the ferrule can only be used once; do not tighten the nut until everything is ready.

About Thread Sealants

Liquid Thread Sealant lubricates and fills the gaps between the fitting threads and leaves no residue that could contaminate the hydraulic fluid.

Other types of thread sealants (like Teflon Tape) can shred during installation or removal and eventually enter the hydraulic system.

Thread sealant may be used with most hydraulic fittings but must be used with NPT connectors.

Apply the thread sealant when the ambient temperature is between +46.5°F to +70°F (+8°C to 21°C).

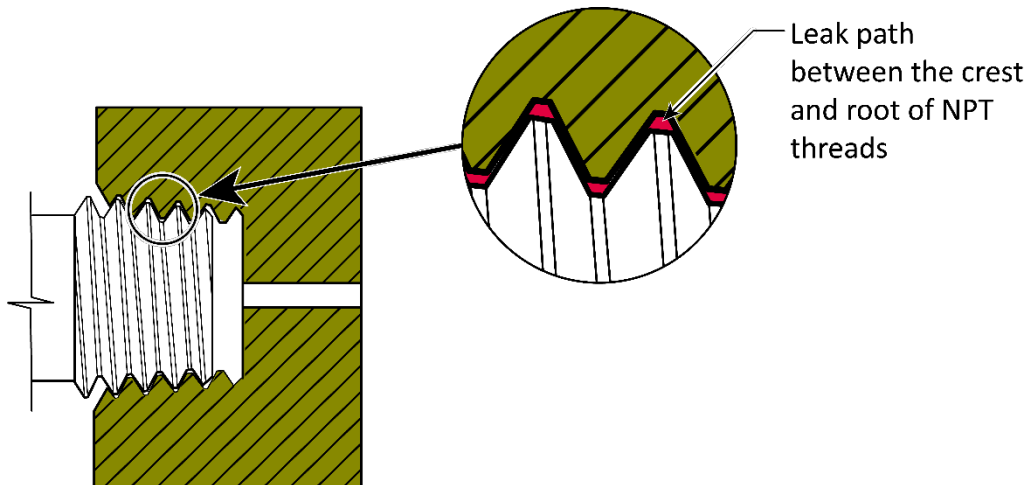

To apply the Thread Sealant:

1. Ensure the fittings and connectors to be used are clean and dry.

If adding thread sealant to a fitting or connector that has already been used with a different sealant, use a wire brush and shop towel to wipe clean and thoroughly remove the old sealant before adding new sealant.

2. Skipping the first thread, apply a small amount of thread sealant to the next four threads of the fitting.

⚠ WARNING Always wear the proper protective equipment when handling thread sealant.

Only a small amount of sealant is required. The sealant spreads to the other threads as it is tightened into place. If too much is applied, the excess liquid will be pushed out when the fitting is tightened. Use a shop towel to remove the excess.

3. Tighten the fitting into the connector. Do **not** over tighten the fitting.
4. Allow the **24-hour** manufacturer-recommended curing time before pressurizing the system.

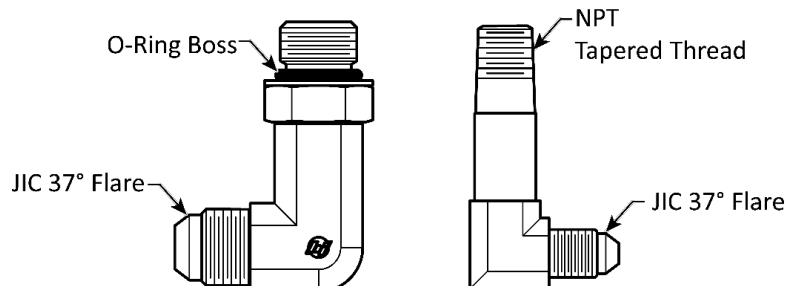

Install the Return Line

The return line routes hydraulic fluid exiting the hydraulic cylinder and returns it back into the Reservoir on the power unit. The return line is a single piece of ¼ in. (6 mm), black, polyethylene tubing with elbow compression fittings on each end. Measure and cut the supplied tubing to the correct length, approx. 53 in. (1,350 mm).

Important: The return line uses the same ¼ in. (6 mm), black, polyethylene tubing as the air lines. Do not confuse the two.

The figures below provide a detailed view of the connection to the hydraulic cylinder.

Components removed for clarity.

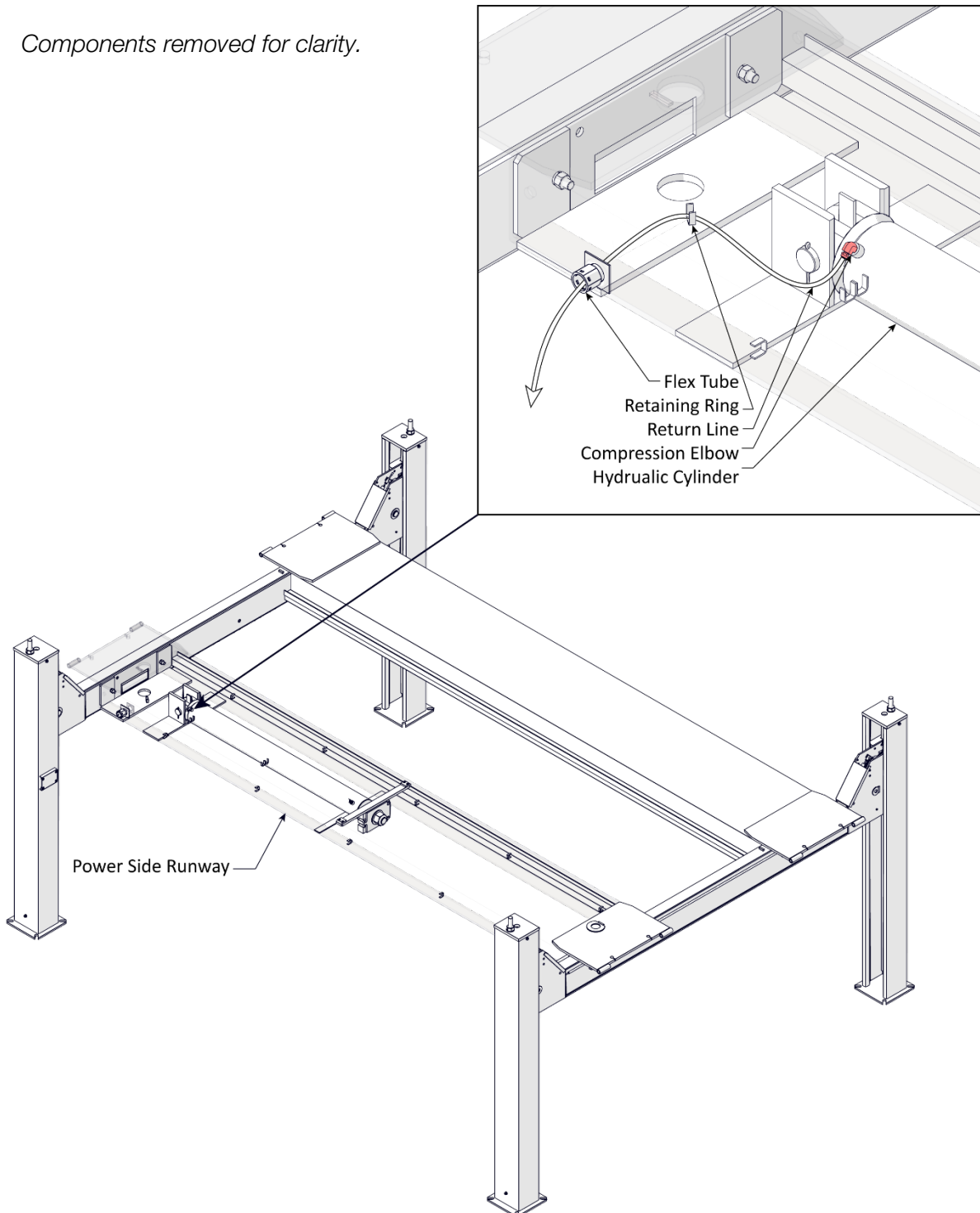

To install the return line:

1. Retrieve the ¼ in. (6 mm) Poly-Flo tubing (5570795) from the parts box.
2. Retrieve the compression elbow fitting -04 Comp x -06NPT (5550089) and thread sealant from the parts bag.
3. Remove the shipping plug from the return port on the hydraulic cylinder.
4. Attach an air pressure source to the return line port and apply pressure to extend the cylinder's piston until it is fully extended.

Do not exceed 50 PSI.

If the cylinder piston does not move, stop using air pressure; instead, use a pulling device (such as a come along tool) to extend the piston. Be careful not to damage the piston or the flange arm assembly.

5. Measure the distance from the return line port on the cylinder to the approximate location of the return line port on the power unit.
6. Cut a piece of tubing to the measured length from the roll of tubing delivered with the Lift. It is best to cut the tubing a little too long rather than a little too short.
7. Route the tubing from the hydraulic cylinder, through the retaining ring on the underside of the power side runway, through the flex tube, and out next to where the power unit will be installed (see the figure on the previous page).

Ensure the return line is routed through the retaining rings so that it is clear of the lift cables that will be routed in the same area.

8. Remove the shipping plug from the return line port on the hydraulic cylinder.
9. Apply thread sealant to the NPT thread end of the elbow compression fitting and thread into the return line port. Orient the connector roughly perpendicular to the centerline of the cylinder pointing toward the flex tube opening in the runway as shown.
10. Connect one end of the return line tubing to the elbow compression fitting you just installed.
11. Leave the power unit end of the return line hanging out of the flex tube for now.

It will be connected to an elbow compression fitting and to the power unit's return port later in the installation.

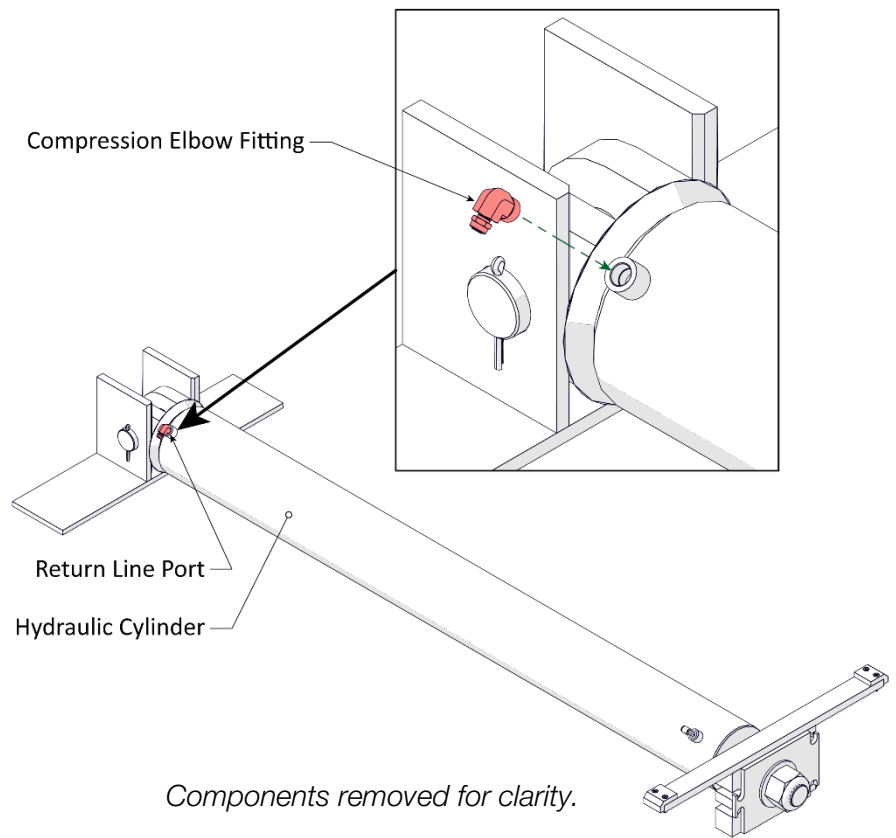

Install the Air Lines

Four pneumatic cylinders use pressurized air to engage and disengage the safety locks.

A minimum air supply of 30psi at 3cfm (2 Bar at .8 cmm) is required to operate the safety locks.

Retrieve the ¼ inch, black, polyethylene tubing and three tee compression connectors. The elbow compression connectors on the pneumatic cylinders are installed at the factory.

Important: Do not confuse the air lines with the return line. They use the same tubing and similar connectors, but the two systems must not be connected to each other.

Components removed for clarity.

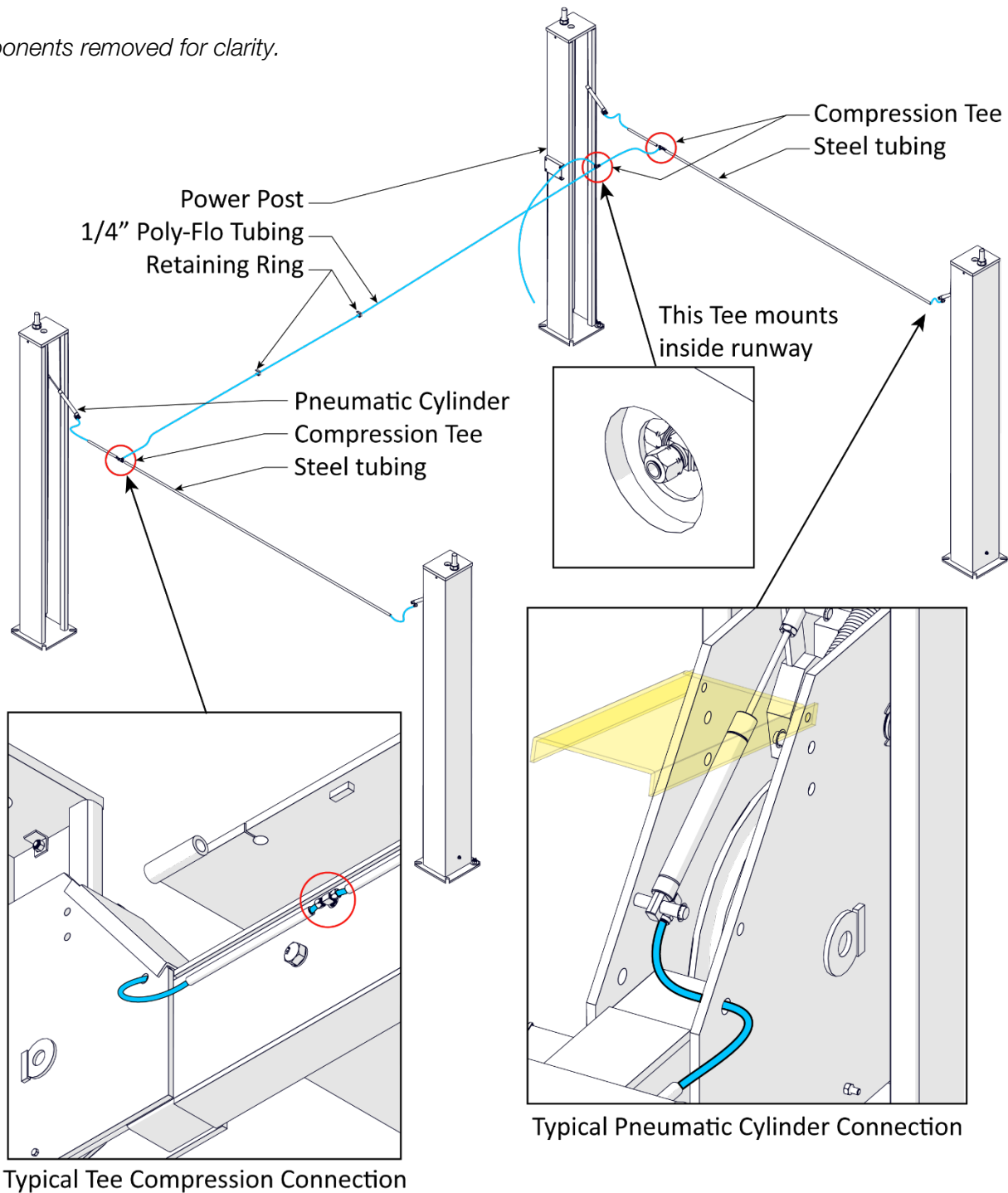

To install the air lines:

1. Retrieve the roll of supplied ¼ inch, black, polyethylene tubing and three tee connectors.
2. Measure the distances for each of the seven (7) tubing pieces required (refer to the figure on the previous page).
3. Cut seven pieces of tubing to the measured lengths.
4. Route the poly-flo tubing *through the steel tubing welded to the crosstubes*.
5. Connect the poly-flo tubing to the tee connectors on the Lift, as shown in the figure on the previous page.

IMPORTANT! Position two tee connectors externally on the crosstubes as shown in the previous figure. The final tee is to be mounted under the power side runway with the last tube exiting down the flex tube.

IMPORTANT! Route the tubing under the power side runway through the retaining rings. Ensure the air lines will not interfere with the lift cables to be routed in the same area.

 **WARNING** Ensure the poly-flo tubing is routed through the steel tubing welded to the Crosstubes. This will protect the tubing and tee connectors keeping them clear of moving parts and vehicles. This is critical for the safe and proper operation of the safety locks. If the air lines become disconnected or damaged, take the Lift out of service until the air lines are repaired.

Refer to **Working with Compression Fittings and Tubing** for more information about connecting the tubing to the air line tee connectors.

6. Leave the power unit end of the air line hanging out of the flex tube.

It will be connected to the pushbutton air valve later in the installation process.



IMPORTANT! PLEASE READ NOW



Hydraulic Fluid Contamination

Hydraulic Fluid Contamination poses a **serious** issue for hydraulically powered Lifts. Contaminants such as water, dirt, or other debris can migrate into the hydraulic hoses and fittings making the Lift inoperable.

This Lift is delivered with clean components; however, BendPak strongly recommends taking a secondary precaution to clean all hydraulic hoses and fittings prior to making connections. It is better and less costly to take these extra steps now rather than taking the Lift out of service later to repair issues that could have been prevented at the time of installation.

There are several acceptable methods to clean hydraulic hoses and fittings:

- **Compressed Air.** Use an air compressor to blow out contaminants from each hydraulic hose and fittings prior to installation. Clean, dry air is preferred. Wear eye protection (safety glasses, goggles, or face shield) when using compressed air for cleaning. Never point an air hose nozzle at any part of your body or any other person.
- **Fluid Flushing.** If the hydraulic fluid is clean and compatible with the system fluid, you can flush hoses and fittings to create a turbulent flow and remove particulates. Always ensure that the fluid itself is contaminant-free.

Some additional steps that will help keep the hydraulic fluid clean:

- **Remove old thread seal tape.** Some ports on the hydraulic cylinders are shipped with temporary plugs secured with thread seal tape. Make sure to thoroughly remove any leftover thread seal tape that may enter the Hydraulic System.
- **Use a liquid thread sealant only.** Teflon paste-type thread sealant or Loctite™ 5452 thread sealant is recommended for all NPT fittings. Do not over tighten NPT fittings or they may crack. Never use thread seal tape on JIC fittings or ORB O-ring fittings.
- **Always use clean equipment.** If you use a dirty bucket or funnel to transfer hydraulic fluid into the hydraulic fluid reservoir, contaminants will likely be introduced into the fluid. When using cleaning rags, use clean lint-free shop towels.
- **Proper storage.** Keep the hydraulic fluid sealed in its container until ready for use. Store the fluid in a clean, dry, and cool area.
- **Cover the Hoses and Fittings.** Before installation, do not leave the ends of hydraulic fittings and hoses open and exposed. Keep dust and shipping plugs in place in a clean area until ready for use.
- **Filter the new hydraulic fluid.** Just because it is new does not necessarily mean it is *clean*. Use an offline filtration cart or kidney loop system to make sure the hydraulic fluid is clean before being transferred into the hydraulic fluid reservoir (even using a heavy-duty nylon mesh screen is better than trusting what is left at the bottom of the barrel).
- **Avoid mixing different types of hydraulic fluid.** If hydraulic fluid requires replacement, make sure to flush the hydraulic system of the old hydraulic fluid before adding the replacement fluid. Never mix the old and new fluids together.

Install the Hydraulic Hose

The hydraulic hose routes hydraulic fluid from the power unit to the hydraulic cylinder.

To install the hydraulic hose:

1. Retrieve the hydraulic hose from the parts box. The 90° fitting end of the hose attaches at the power unit and the straight end at the hydraulic cylinder.

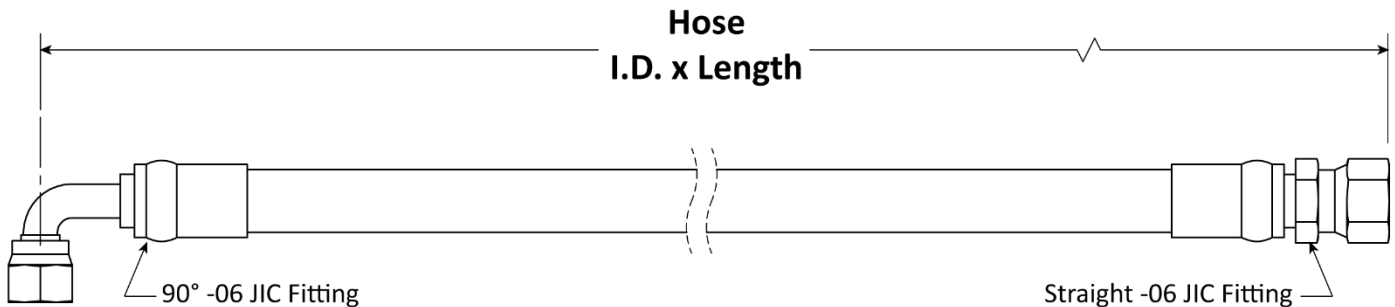

Lift Model	Part Number	Hose I.D. x Length	Qty.
HDS-18E HDS-27	5570901	Ø10 x 5,385	1
HDS-40	5570149	Ø10 x 5,385	1
HDS-27X HDS-40X	5570900	Ø10 x 6,782	1
HDS-40FL	5570287	Ø10 x 3,861	1

2. Retrieve one JIC to NPT hydraulic elbow fitting from the parts bag. The NPT end connects to the hydraulic cylinder and the JIC end attaches to the straight JIC end of the hydraulic hose.

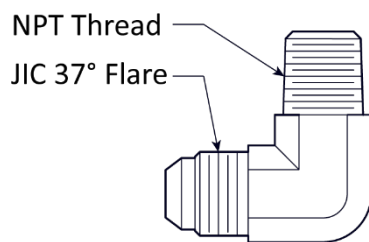

3. On the hydraulic cylinder, remove the shipping plug from the threaded port at the piston rod end.
4. Ensure the port and elbow threads are clean.
5. Apply thread sealant to the NPT side of the JIC-to-NPT elbow fitting and thread into the hydraulic cylinder port. Tighten until secure.

Leave the JIC connector pointing parallel to the centerline of the hydraulic cylinder facing toward the flex tube.

6. Feed the straight end of the hydraulic hose through the flex tube and retaining rings routing to the hydraulic cylinder JIC elbow just installed.

The 90° end should exit the flex tube near the power post.

7. Attach the straight end of the hydraulic hose to the JIC connector that is facing up.
Tighten to secure.
8. Leave the 90° end of the hydraulic hose exiting Flex Tube; do not connect it will be connected to the power unit later in the procedure.
9. The figure below details the fittings and hydraulic hose routing between the cylinder and the power unit and through the flex tube.

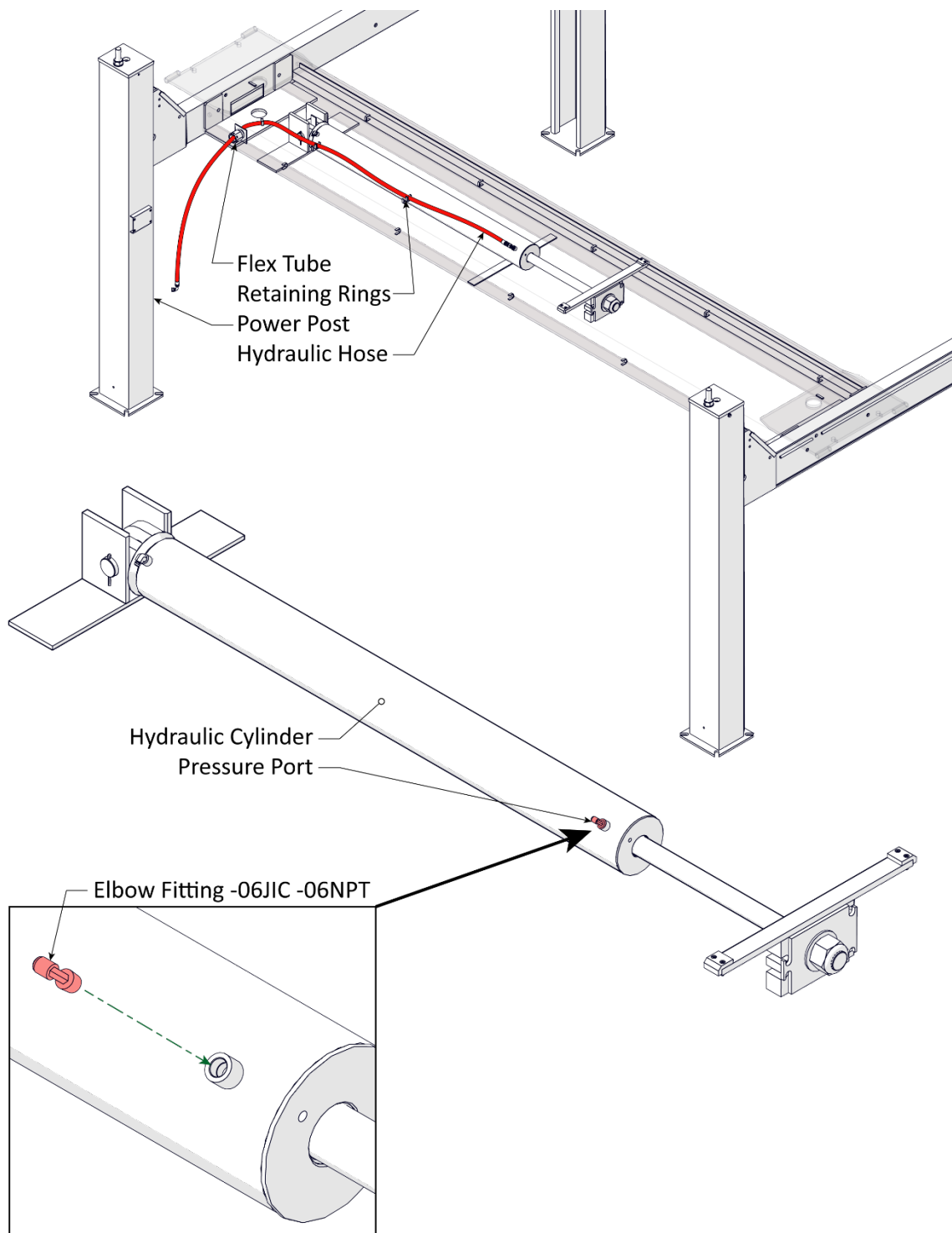
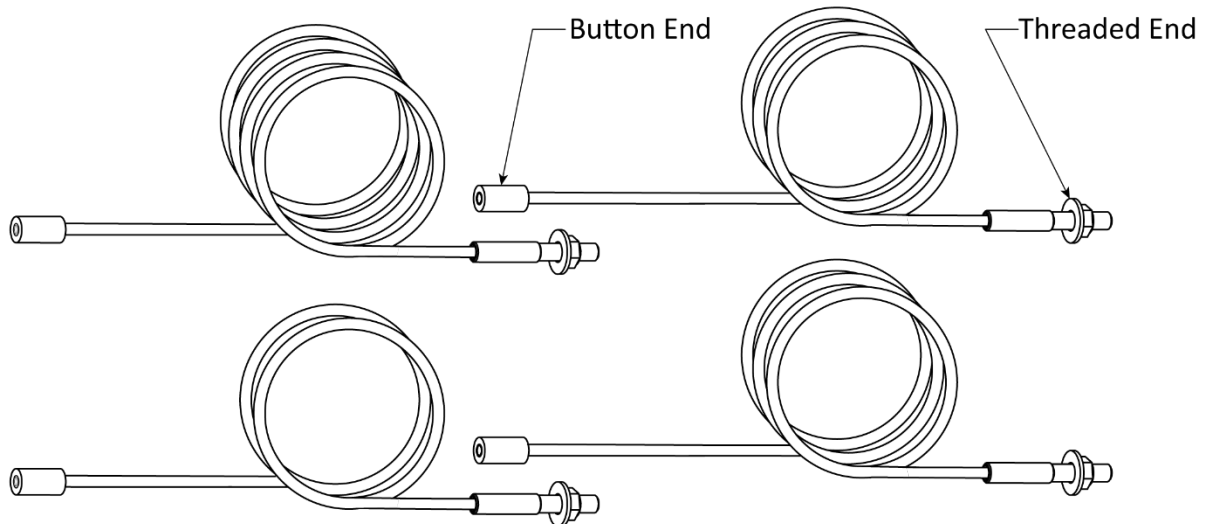

Figure not to scale. Not all components shown.

Route the Lift Cables

Before routing the cables on the Lift, review the following:

- Always wear appropriate protective clothing including gloves when working with the Lift cables.
- Each Lift includes four Lift cables. All four are different lengths and only function correctly in one position. If installed in the wrong position, the cable will be too short or too long.
- All four cables have a button end and a threaded end. The threaded end includes a label that identifies the Lift model, the part number, and its length (in millimeters).



- The button end of each cable connects at the cable retainer block on the underside of the power side runway. The button ends of each cable remain on one side of the retainer block while the cable passes through the retaining block and the retaining plate on its way toward the appropriate sheaves and ultimately to the Lift post where it attaches to the top cap.

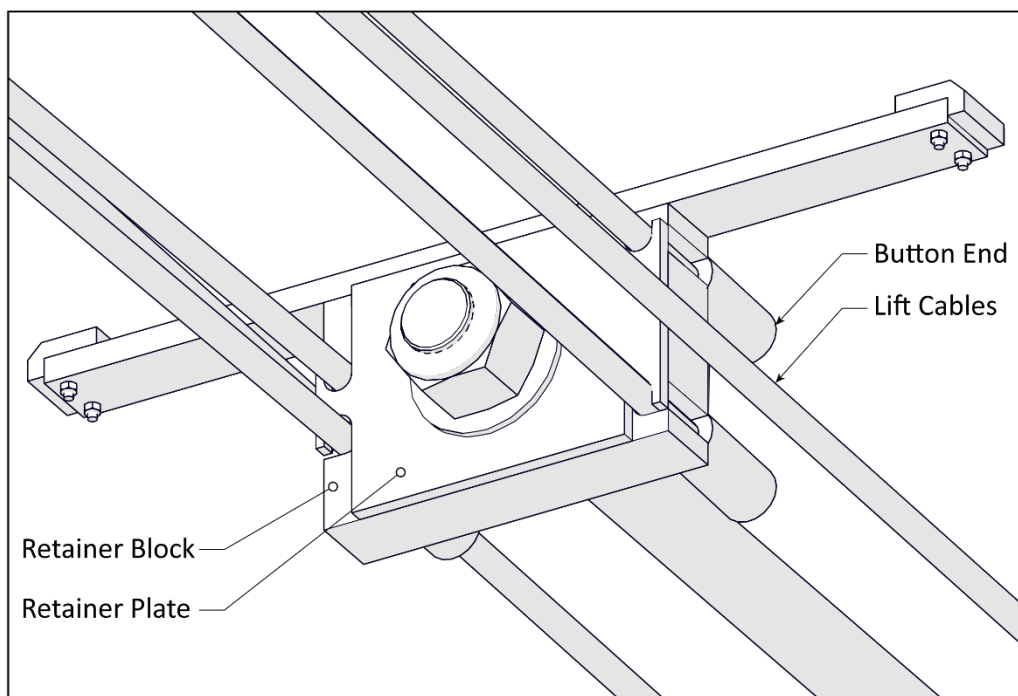

- The threaded end of each cable routes around the appropriate sheaves and is then routed to a lift post, where it is attached at the top cap.
- The Retaining Plate holds the button ends of the cables in place after all four cables are installed. Do not remove the retaining plate to install the cables; instead, loosen it so that the Button end of the cable can be slipped into the correct slot. When all four cables are installed, tighten the retaining plate in place.
- There are two kinds of sheaves: cable sheaves and gusset sheaves. There are four cable sheaves at the rear of the power side runway and two cable sheaves at the front of the power side runway, for a total of six cables sheaves. There are four gusset sheaves, one on each crosstube gusset.
- Cable sheaves are installed in the power side runway. However, they must be removed prior to putting the runways in place on the crosstubes. When routing the cables, all the cable sheaves should have been removed.
- Gusset sheaves are installed in the crosstubes and **must not** be removed.
- Cable sheaves are reinstalled as each cable is routed. All of the six cable sheaves (two at the front of the Lift, four at the rear) are identical.
- The two cable sheave **pins** are also identical.
- A cable and its corresponding cable sheave (or sheaves) are put into place one at a time, starting from the retaining block to the top of the post. Cables and their cable sheaves must be put into place at the same time. Do not install the next cable/cable sheave pair until the previous cable/cable sheave pair are in place.
- Each crosstube gusset has a cable lock pin just under the bottom of the gusset sheave. Each cable lock pin must be removed to allow routing the cable. Reinstall the cable lock pin once the cable is in place.

The cable lock pin prevents the cable from exiting the sheave groove.

- In the figures and procedures on the following pages, the cables and cable sheaves are labelled A, B, C, and D. These letters indicate the order in which they are put into place. Cable A and cable sheave A are put into place first, then cable B and cable sheave B, and so on. These letters are **not** on the label on the cable. Match the cable letter with the length information in the tables that follow.
- The order in which the cables and sheaves are put into place is based on the order the cable sheaves must be replaced, **not the length of the cables**.
- All four cables routes begin at the retainer block and then route around a cable sheave at the **Rear** of the Lift. Cables A and B then route around the gusset sheave at the posts to which they attach.

Cables C and D begin at the retainer plate and route around a cable sheave at the rear of the Lift, and then are routed to the front of the Lift where they route around another cable sheave, and travel to the gusset sheave at the posts to which they attach.

See the figures and procedures on the following pages for detailed routing information.

Lift Cable Identification Tables

HDS-18E / HDS-27		
Cable	Length	Part Number
A	Ø16 x 4,127 mm	5595835
B	Ø16 x 5,855 mm	5595836
C	Ø16 x 10,483 mm	5595806
D	Ø16 x 12,215 mm	5595807

HDS-27X		
Cable	Length	Part Number
A	(Ø16 x 4,127 mm)	5595835
B	(Ø16 x 5,855 mm)	5595836
C	(Ø16 x 12,007 mm)	5595808
D	(Ø16 x 13,739 mm)	5595809

HDS-40		
Cable	Length	Part Number
A	(Ø19 x 4,102 mm)	5595558
B	(Ø19 x 5,836 mm)	5595559
C	(Ø19 x 10,452 mm)	5595564
D	(Ø19 x 12,167 mm)	5595565

HDS-40X		
Cable	Length	Part Number
A	(Ø19 x 4,102 mm)	5595558
B	(Ø19 x 5,836 mm)	5595559
C	(Ø19 x 12,027 mm)	5595562
D	(Ø19 x 13,742 mm)	5595563

HDS-40FL		
Cable	Length	Part Number
A	(Ø19 x 4,102 mm)	5595558
B	(Ø19 x 5,836 mm)	5595559
C	(Ø19 x 8,928 mm)	5595692
D	(Ø19 x 10,643 mm)	5595693

Important: Ensure the correct cable is used for each route. A cable installed in the wrong position will be too short or too long. The length of each cable is printed on the label on the threaded end.

The figure below provides an overview of the cable routes.

Components removed for clarity

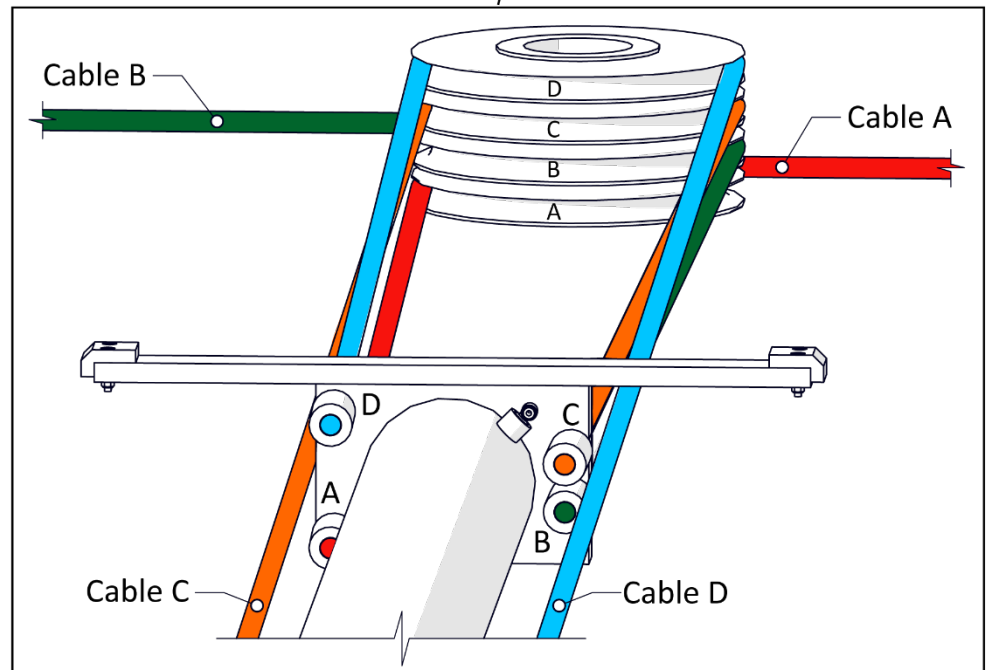
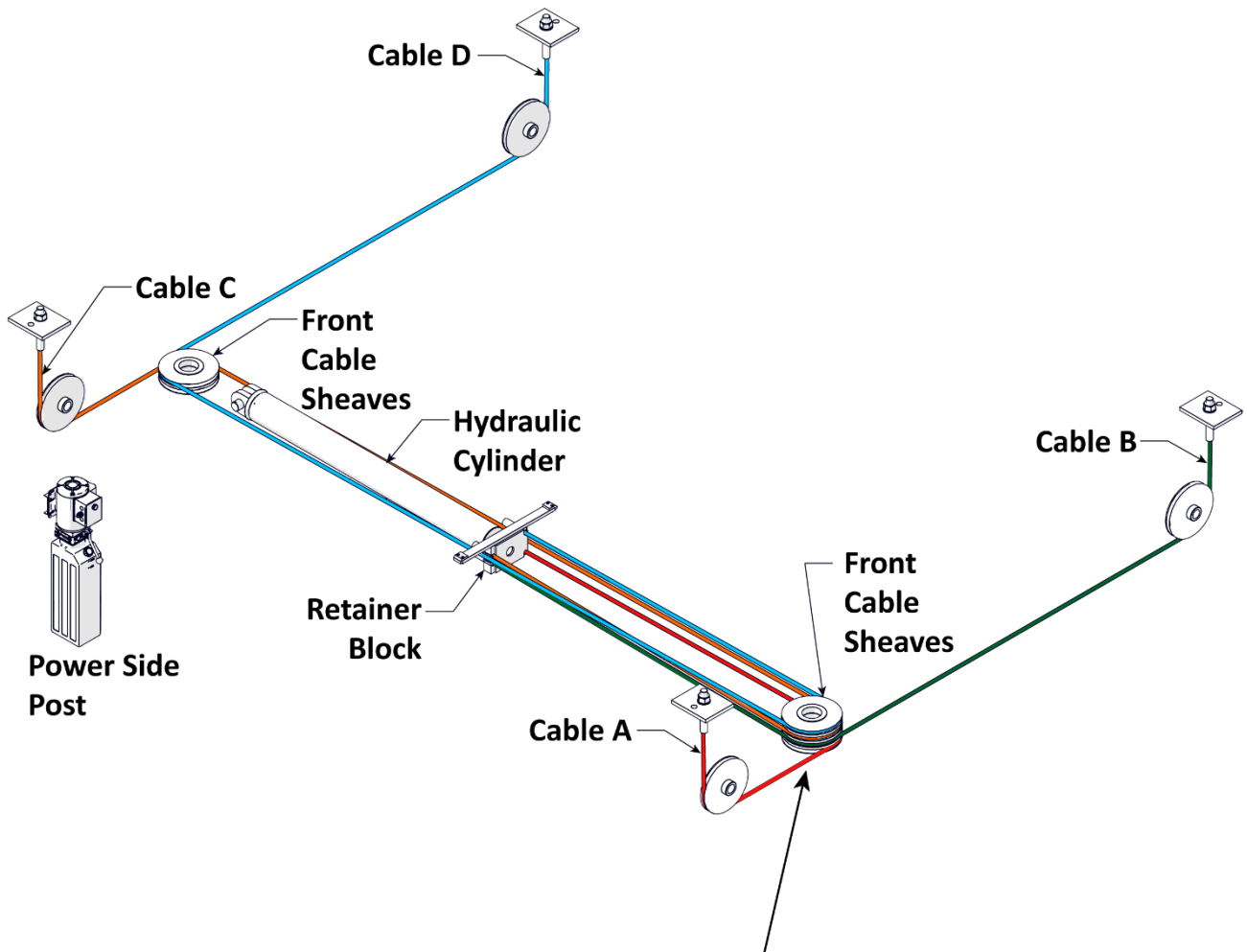

Before routing the lift cables, verify the cylinder's piston has been extended. See **Installing the Return Line**. If the piston has **not** been extended, extend it now.

Route Cable A to the rear post:

1. Retrieve the four lift cables from the parts box.
Check the labels on each cable match the tables provided on the previous pages.
2. Retrieve the six cable sheaves and spacers removed prior to installing the runways.
Do **not** remove the gusset sheaves.
3. Retrieve cable A. Remove the nut and washer from the threaded cable end and store in a safe place for later installation.
4. Under the power side runway, loosen the cable retaining plate enough so that the button end of each cable may be installed into its slot on the cable retaining block.

Do not remove the retaining plate! Loosen the hex nut enough to provide room to slip the button end of each cable into place.

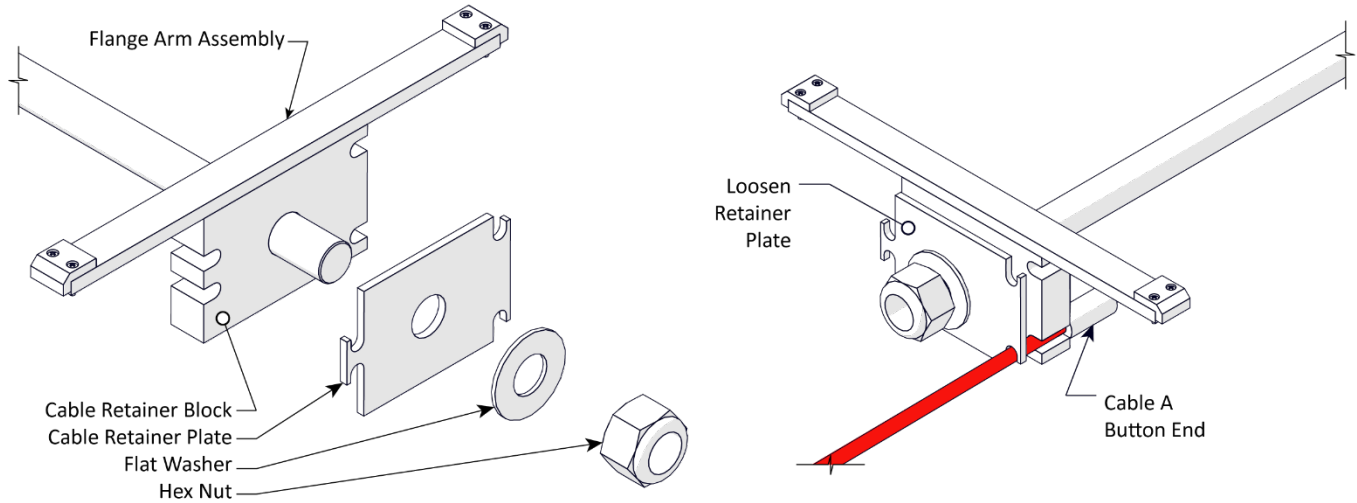

5. Slip the button end past the retaining plate and into its slot on the retaining block. Refer to the figure above.
6. Route the threaded end of the cable toward its cable sheave location at the rear of the Lift. Refer to the prior figures in this section.

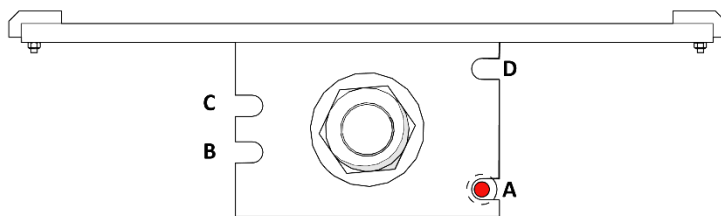

Figure shows cable A in its slot on the retaining block.

View is from rear of the Lift looking toward the hydraulic cylinder and the power post. Components removed for clarity.

7. Route the cable into the large window on the crosstube, push it toward the closest lift post, then pull the threaded end out of the crosstube at the bottom of the gusset. Allow the threaded end to hang out of the crosstube for the moment.

- Put sheave A into place, at the bottom of what will be a stack of four cable sheaves when all four cables are in place, then ensure cable A is seated in the rear sheave A groove.

NOTE: Replace the ramp spacers and sheave spacers when returning the sheaves as shown below.

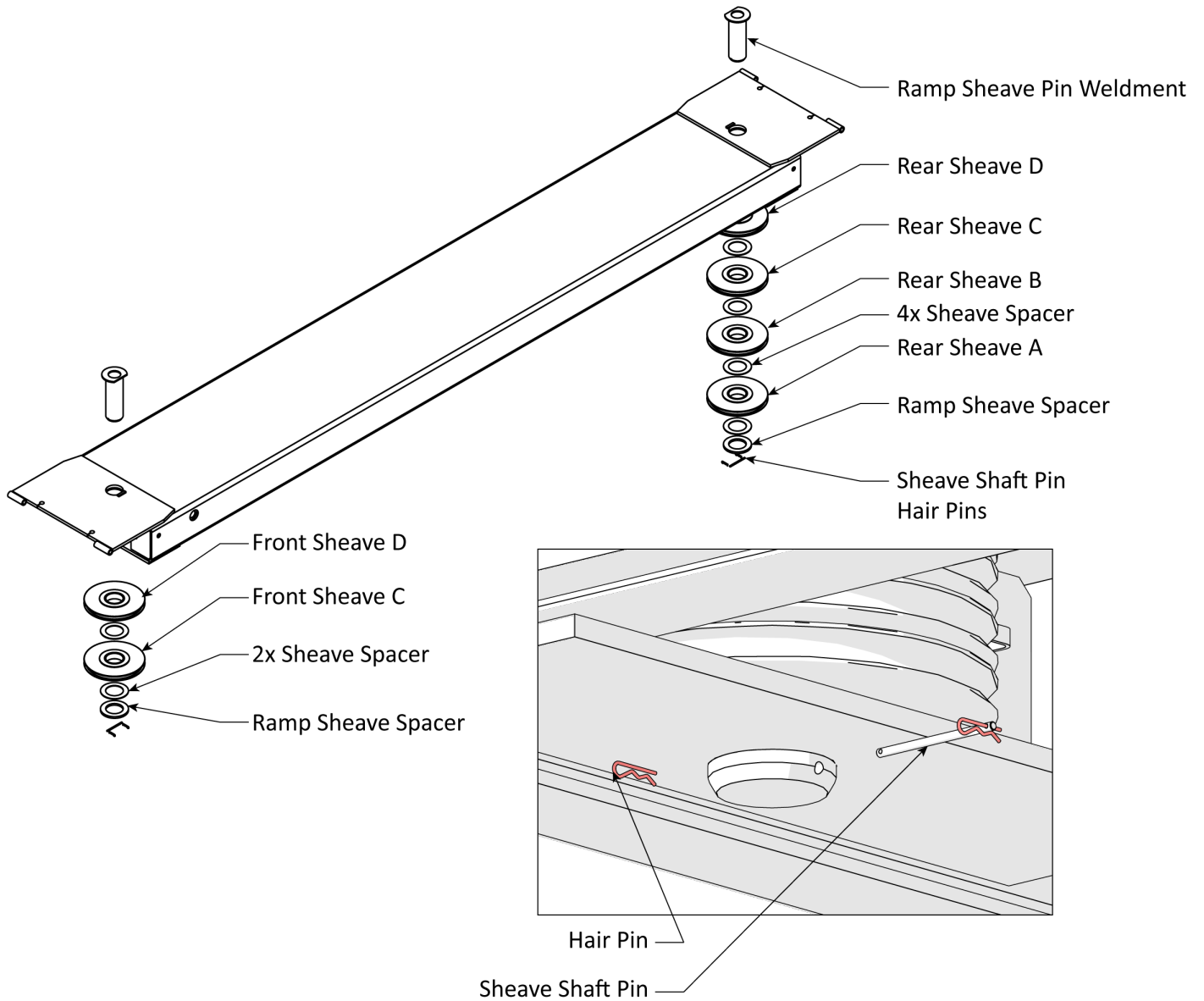

9. Remove the cable lock pin on the bottom of the gusset for cable A, refer to the figure below. Retain this pin, it will be reinstalled later in the process.
10. Route the threaded end of cable A **under** the gusset sheave, then up towards the top cap at the top of the Post.

IMPORTANT! When routing the cable up the post, it **must** be routed between the gusset sheave and the slack safety sheave, as shown in the figure below.

Gusset plate removed for clarity. Drawing not to scale.

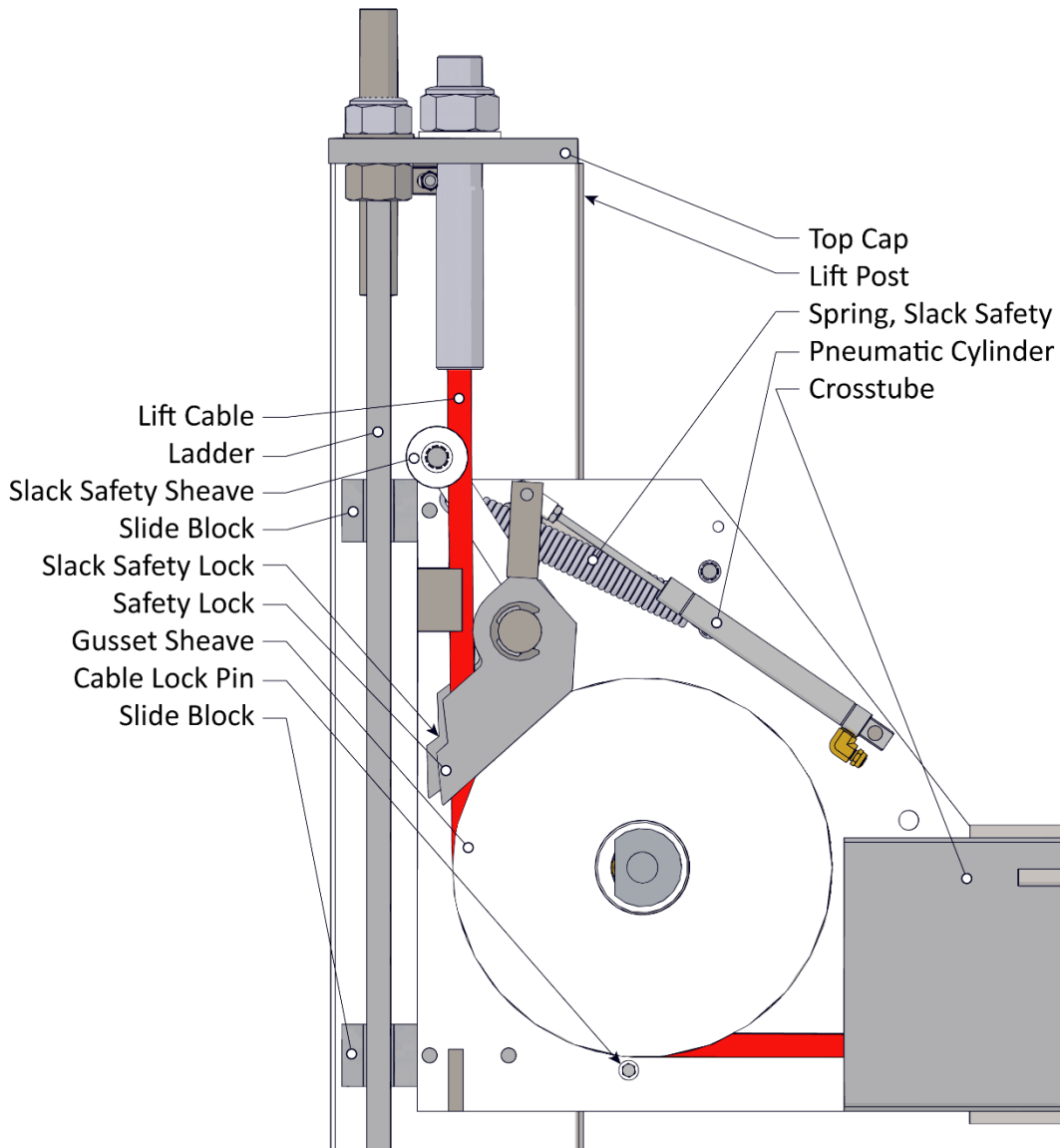

Important: When routing a cable in its post, the cable must route **under** the gusset sheave and then, when it heads up towards the top of the post, it must be on the side of the slack safety sheave, as shown above. When the cables are pulled tight, the cable prevents the slack safety from engaging. If the cable is **not in this exact location**, the slack safety will **not** function correctly.

11. Push the threaded end of cable A through the top cap and **hand tighten** it in place with the nut removed before beginning to route the cable.

Only hand tighten the nut at this point so that there is a little play in the cabling. All four nuts will be secured later in the installation procedure.

Note: The threaded end of cable A should extend just a short way through the top cap. If it is too long or too short, check to see if the wrong cable is installed. If it is just a few inches short, then the piston may not have been pulled out far enough.

12. Reinstall the cable lock pin near the bottom of the crosstube gusset.

Cable A is now correctly routed to its post.

Route Cable B to the Rear Off Side Post:

1. Retrieve cable B. Remove the nut and washer from the threaded cable end and store it in a safe place for later installation.
2. Under the power side runway, loosen the cable retaining plate enough so that the button end of each cable may be installed into its slot on the cable retaining block.

Do not remove the retaining plate! Loosen the hex nut enough to provide room to slip the button end of each cable into place.

3. Slip the button end past the retaining plate and into its slot on the retaining block (cable B mounts on the other side of the retaining block).

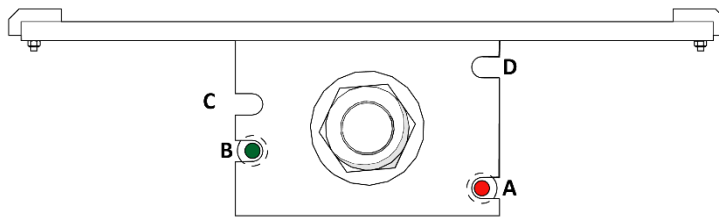

The figure displays cable B in its slot on the retainer block.

View is from rear of the Lift looking toward the hydraulic cylinder and the power post. Components removed for clarity.

4. Route the threaded end of the cable towards the rear of the Lift.
5. Route the cable into the large window on the crosstube, push it toward the rear off side post, then pull the threaded end out of the crosstube at the bottom of the gusset. Let the threaded end hang out of the crosstube for the moment.
6. Retrieve the spacer and move rear sheave B into place, on top of Rear Sheave A. Make sure cable B is seated in rear sheave B groove.
7. Remove the cable lock pin on the bottom of the gusset on the rear off side post. Retain this pin, it will be reinstalled later in the process.
8. Route the threaded end of cable B **under** the gusset sheave, then up towards the top cap at the top of the rear off side post.

Important: When routing a cable in its post, the cable must route **under** the gusset sheave and then, when it heads up toward the top of the post, it must be on the side of the slack safety sheave, as shown in the figure on the previous page. When the cables are pulled tight, the cable prevents the slack safety from engaging. If the cable is **not in this exact location**, the slack safety will **not** function correctly.

9. Push the threaded end of cable B through the top cap and **hand tighten** it in place with the nut removed before beginning to route the cable.

Only hand tighten the nut at this point so that there is a little play in the cabling. All four nuts will be secured later in the installation procedure.

Note: The threaded end of cable B should extend just a short way through the top cap. If it is too long or too short, check to see if the wrong cable is installed. If it is just a few inches short, then the piston may not have been pulled out far enough.

10. Reinstall the cable lock pin near the bottom of the crosstube gusset.

Cable B is now correctly routed to the rear off side post.

Important: The two sheaves at the front of the Lift are termed front power side sheave C and front off side sheave D in this manual.

Route Cable C to the Power Post:

1. Retrieve cable C. Remove the nut and washer from the threaded cable end and store in a safe place for later installation.
2. Under the power side runway, loosen the cable retaining plate enough so that the button end of each cable may be installed into its slot on the cable retaining block.

Do not remove the retaining plate! Loosen the hex nut enough to provide room to slip the button end of each cable into place.

3. Slip the button end past the retaining plate and into its slot on the retaining block (cable C mounts above cable B on the retaining block).

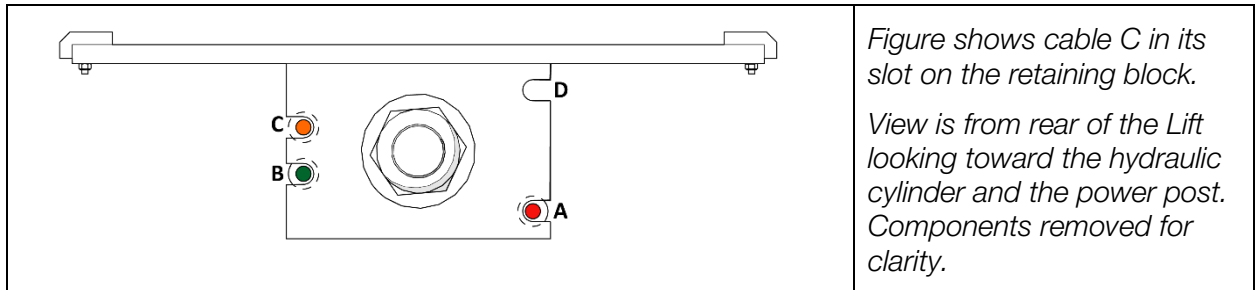

4. Cable C will route around the cable sheaves at the rear of the Lift and then head back towards the front of the Lift. Route the threaded end of the cable towards the rear of the Lift.
5. Route the cable into the large window on the crosstube.
6. Retrieve the spacer and move rear sheave C into place, on top of rear sheave B. Make sure cable C is seated in rear sheave C.
7. Pull the threaded end of cable C all the way to the front of the Lift, then push the threaded end into the small window, directing it toward the power side post.
8. Pull the threaded end out of the crosstube at the bottom of the gusset at the power side post. Let the threaded end hang out of the crosstube for the moment.

- Put front sheave C into place with its spacers, in the small crosstube window as shown below. Ensure cable C is seated in front sheave C groove.

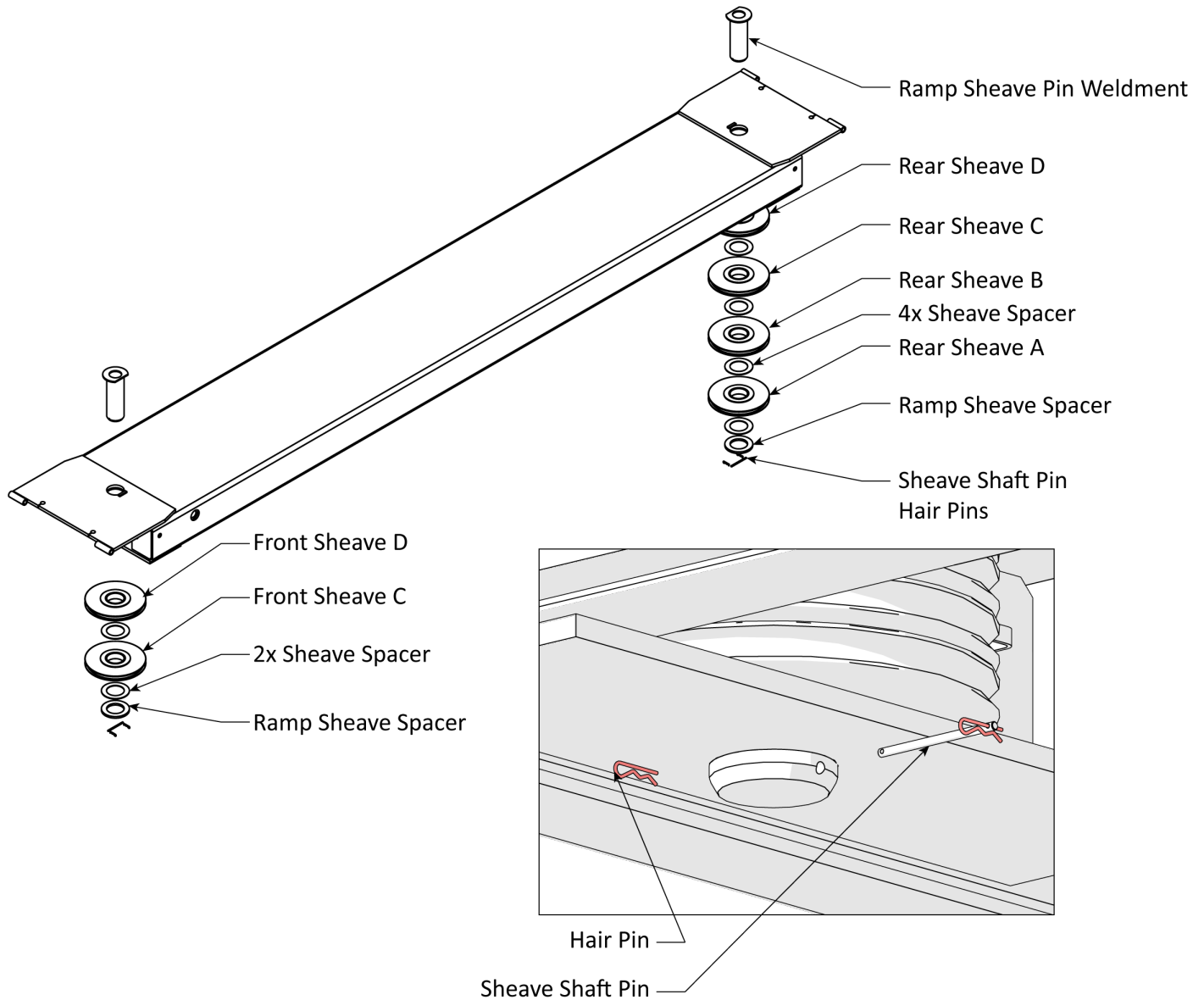

- Remove the cable lock pin on the bottom of the gusset on the rear off side post. Retain this pin, it will be reinstalled later in the process.
- Route the threaded end of cable C **under** the gusset sheave, then up towards the top cap at the top of the rear off side post.

Important: When routing a cable in its post, the cable must route **under** the gusset sheave and then, when it heads up toward the top of the post, it must be on the side of the slack safety sheave, as shown in the figure on the previous page. When the cables are pulled tight, the cable prevents the slack safety from engaging. If the cable is **not in this exact location**, the slack safety will **not** function correctly.

- Push the threaded end of cable C through the top cap and **hand tighten** it in place with the nut and washer removed before beginning to route the cable.

Only hand tighten the nut at this point so that there is a little play in the cabling. All four nuts will be secured later in the installation procedure.

Note: The threaded end of cable C should extend just a short way through the top cap. If it is too long or too short, check to see if the wrong cable is installed. If it is just a few inches short, then the piston may not have been pulled out far enough.

13. Reinstall the cable lock pin near the bottom of the crosstube gusset.

Cable C is now correctly routed to the rear off side post.

Route Cable D to the Front Off Side Post:

1. Retrieve cable D. Remove the nut and washer from the threaded cable end and store in a safe place for later installation.
2. Under the power side runway, loosen the cable retaining plate enough so that the button end of each cable may be installed into its slot on the cable retaining block.

Do not remove the retaining plate! Loosen the hex nut enough to provide room to slip the button end of each cable into place.

3. Slip the button end of cable D past the retaining plate and into its slot on the retaining block (cable D mounts above cable A on the retaining block).

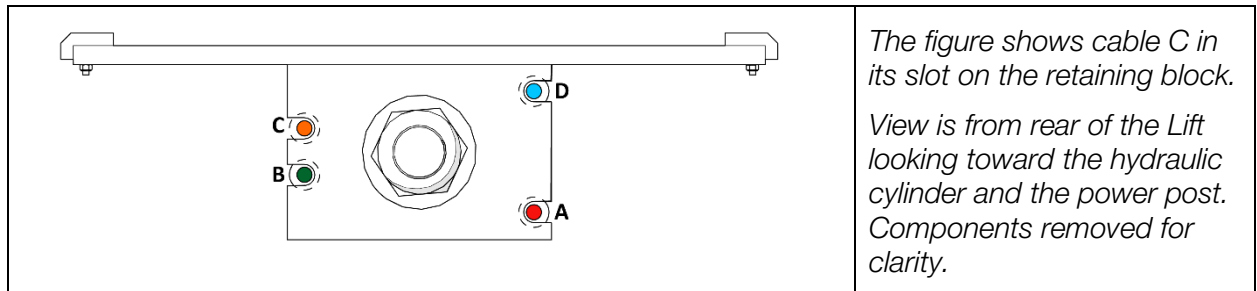

4. Cable D will route around the cable sheaves at the rear of the Lift and then head back toward the front of the Lift. Route the threaded end of the cable towards the rear of the Lift.
5. Route the cable into the large window on the crosstube.
6. Retrieve the spacer and move rear sheave D into place, on top of rear sheave C. Make sure cable D is seated in rear sheave D.
7. Pull the threaded end of cable D all the way to the front of the Lift, then push the threaded end into the small window, directing it toward the off side front post.
8. Pull the threaded end out of the crosstube at the bottom of the gusset at the off side front post. Allow the threaded end hang out of the crosstube for the moment.
9. Move front sheave D into place, in the small crosstube window with its spacers. Ensure cable D is seated in front sheave D.

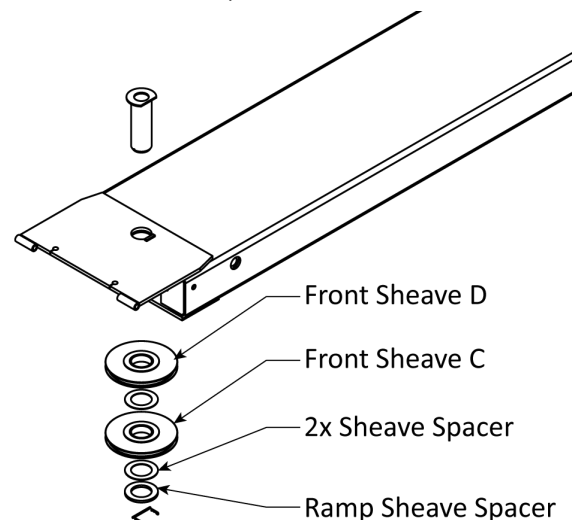

10. Pull the threaded end out of the crosstube at the bottom of the gusset. Allow the threaded end hang out of the crosstube for now.
11. Remove the cable lock pin on the bottom of the gusset on the rear off side post. Retain this pin, it will be reinstalled later in the process.
12. Route the threaded end of cable D **under** the gusset sheave, then up toward the top cap at the top of the front power side post.

Important: When routing a cable in its post, the cable must route **under** the gusset sheave and then, when it heads up toward the top of the post, it must be on the side of the slack safety sheave. If the cable is **not in this exact location**, the slack safeties will **not** function correctly.

13. Push the threaded end of cable D through the top cap and **hand tighten** it in place with the nut removed before routing the cable.

Only hand tighten the nut at this point so that there is a little play in the cabling. All four nuts will be secured later in the installation procedure.

Note: The threaded end of cable D should extend just a short way through the top cap. If it is too long or too short, check to see if the wrong cable has been installed.

14. Reinstall the cable lock pin near the bottom of the crosstube gusset.

Cable D is now correctly routed to the front off side post.

15. Lubricate all sheave pins and sheave bearings with red lithium grease.
16. Reinstall the sheave shaft pin and secure using the hairpin cotter pins.
17. Inspect to ensure that each cable is routed up each lift post between the slack safety sheave and the gusset Sheave.
18. Inspect to ensure each cable is seated in the correct sheave and rides in the middle of the sheaves' groove. Adjust as required to achieve this.
19. Inspect to ensure all four cable lock pins (at the bottom of each cross tube gusset) are installed securely in place with the cables routed **above** them. Correct or install as required.

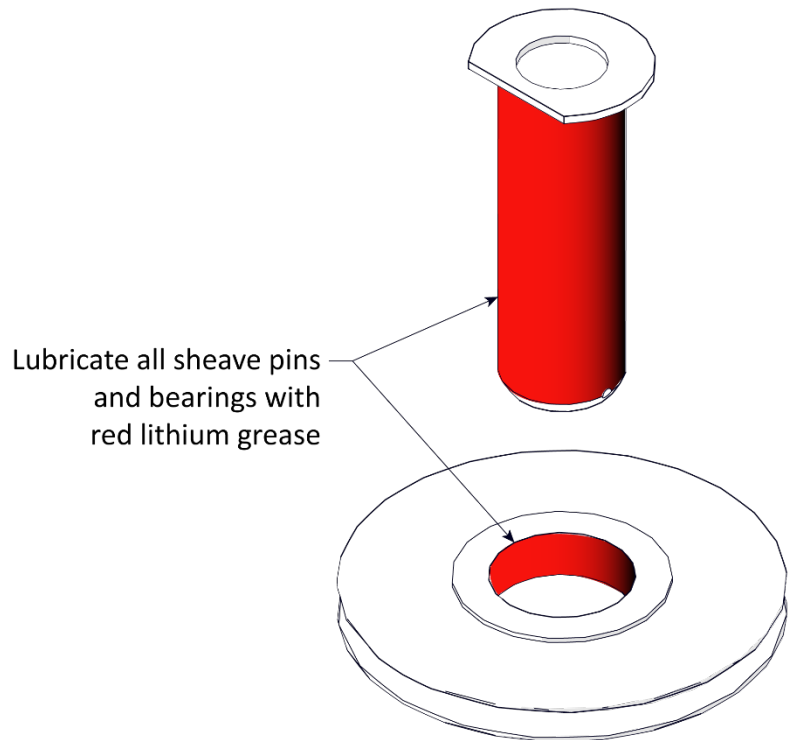

20. Cable routing is now complete.

Install the Power Unit

This section describes how to mechanically attach the power unit to the power side post. An electrician is **not** required for this step but is required to connect the power unit to the facilities' electrical service.

1. Retrieve the power unit and the parts listed below from the parts bag and parts box.

Item	Part Number	Description	Qty.
1	–	Power Unit Mounting Bracket	1
2	5715003	Vibration Dampener	1
3	–	Power Unit	1
4	5545202	M8 Lock Washer, Split Ring	4
5	5530050	M8 x 15 Hex head Bolt	4

2. Line up the openings on the power unit back plate with the four openings in the mounting bracket.
3. Secure the vibration dampener, and power unit using the fasteners called out in the list above.
4. Fill the hydraulic reservoir on the power unit with approved fluids.

The hydraulic reservoir holds approximately 7 gallons (26.5 liters). Use care to keep the fluid clean when filling the reservoir.

Approved fluids are any general purpose ISO-32, ISO-46, or ISO-68 hydraulic fluid. Alternatively, approved automatic transmission fluids such as Dexron VI, Mercon V, Mercon LV, or any synthetic multi-vehicle automatic transmission fluid.

Do not connect the Power Unit to the facility electrical service at this point.

⚠ DANGER Risk of explosion: The Power Unit has internal arcing or parts that may spark and should not be exposed to flammable vapors. Never expose the Power Unit motor to rain or other damp environments. Damage to the motor caused by water is **not** covered by the warranty.

⚠ WARNING Do not run the power unit without hydraulic fluid. It will be damaged.

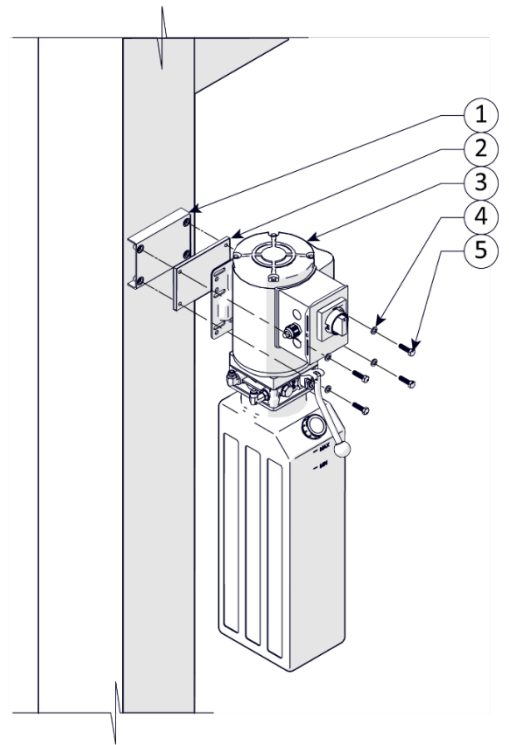

Complete the Flex Tube Installation

Install the second end of the flex tube (the other end was connected to the power side runway earlier in the installation).

The flex tube consolidates and protects the lines exiting the power side runway. The air line, the return line, and the hydraulic hose.

To install the flex tube, first connect the flex tube bracket plate and the flex tube angle plate.

Flex Tube Bracket Plate

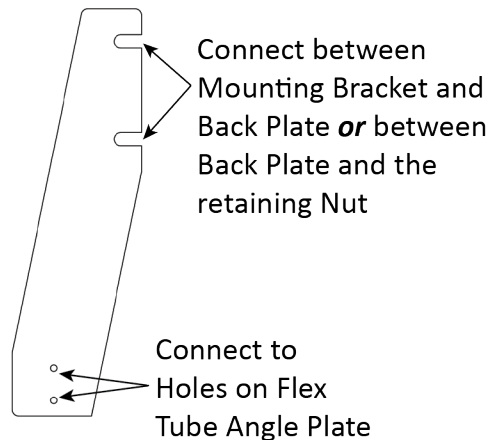

Flex Tube Angle Plate

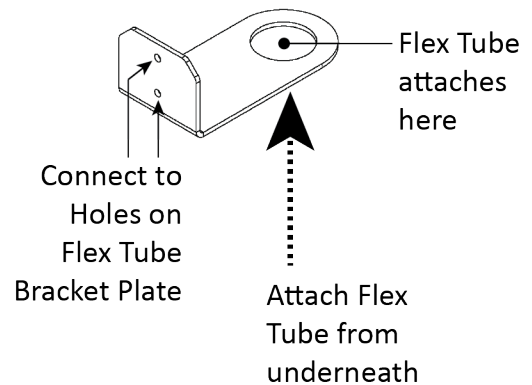

The components involved include:

- **Flex Tube.** Protects the air line, the return line, and the hydraulic hose. Connects to the hole on the Flex Tube Angle Plate from underneath.
- **Flex Tube Bracket Plate.** The two notches at the top attach near the Mounting Bracket on the Power Post. The two holes at the bottom connect to the Flex Tube Angle Plate.
- **Flex Tube Angle Plate.** Attaches to the flex tube bracket plate via two holes, giving you the flexibility to connect it to either side. Includes the hole to which the Flex Tube connects.

BendPak recommends orienting the flex tube so that the lines exit near where they connect to the power unit and to the pushbutton air valve.

Install the Pushbutton Air Valve

Install the pushbutton air valve, which requires the zero angle bracket.

The pushbutton air valve is used to release the safety locks and lower the runways. It may be installed on either side of the power unit, whichever is easier to access for the lift operator.

Once the pushbutton is in place, you need to connect it to the air line (which is coming out of the flex tube) on one end and the customer-supplied air pressure on the other end. ***A minimum air pressure of 30 psi at 3 cfm (2 Bar at .8 cmm) min. is required.***

The figure below details the zero angle bracket connection.

Zero Angle Bracket

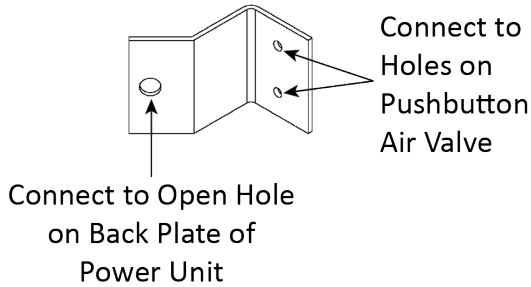

Pushbutton Air Valve

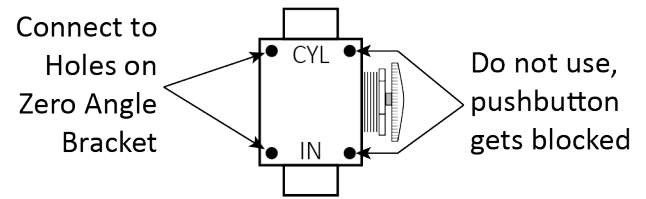

The components involved include:

- **Zero Angle Bracket.** Attaches at the mounting bracket on the power post or to other available openings on the power unit mounting bracket. Holds the pushbutton air valve, be sure to orient the Zero Angle Bracket so that the pushbutton air valve can be easily reached by the Lift operator.
- **Pushbutton Air Valve.** Used to release the safety locks allowing the runways to be lowered.
- **Air Line Compression Elbow Fitting.** Connects the pushbutton air valve to the air line exiting of the flex tube.
- **Straight Expander Fitting.** Connects the pushbutton air valve to the customer-supplied air pressure. A minimum air pressure of 30 psi at 3 cfm (2 bar at .08 cmm) is required.

To install the pushbutton air valve:

1. Retrieve the necessary components. Zero angle bracket, pushbutton air valve, air line, compression elbow fitting, and straight expander fitting.

2. Connect the zero angle bracket at the desired location (if it has not already been connected).

It can attach to an available opening on the power unit mount or to one of the bolts that connect the power unit to the mounting bracket on the power post.

The best location is one that is visible and easily reached by the Lift operator.

3. Connect the pushbutton air valve to the zero angle bracket.

Use the two holes on the pushbutton air valve on the side away from the actual pushbutton. If you use the holes next to the pushbutton, the zero angle bracket interferes with the pushbutton during use.

The figure to the right details the pushbutton air valve and its connections.

4. Clean the compression and expander fittings and apply thread sealant to the NPT threads. Connect the air line compression elbow fitting and the straight expander fitting to the appropriate locations on the pushbutton air valve.

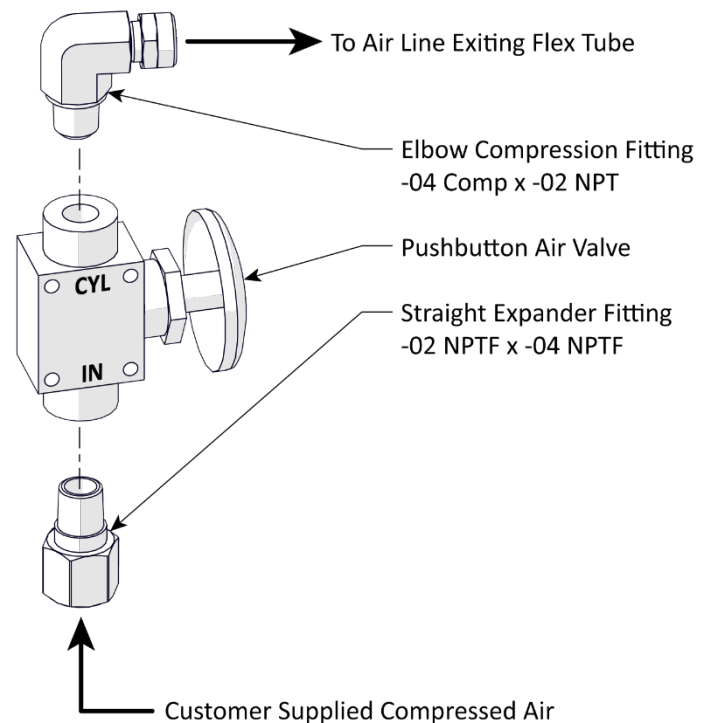

The elbow compression fitting connects to the opening labelled **CYL**. The straight expander fitting connects to the opening labelled **IN**. See the figure above.

5. Attach the air line (exiting the Flex Tube) to the compression fitting on the elbow fitting and the customer-supplied air to the straight fitting.

Important: The return line also exits the flex tube and is the same type of tubing as the air line. ***Do not attach the return line to the pushbutton air valve!*** Double check to ensure you are attaching the air line to the pushbutton air valve.

For the customer-supplied air pressure, a minimum of 30 psi at 3 cfm (2 Bar at .8 cmm) min. is required.

Connect the Return Line

The return line connects to the hydraulic return port on the power unit.

One end of the return line is already connected to the hydraulic cylinder; the other end should be exiting the Flex Tube.

To attach the return line to the power unit:

1. Locate the hydraulic return port T on the power unit and remove the shipping plug. There is only one hydraulic return port on the power unit.
2. Apply thread sealant to the NPT thread side of the return line compression fitting.
3. Tighten the threaded end of the elbow compression fitting into the hydraulic return port T.

For information about connection compression fittings, refer to [Working with Compression Fittings and Tubing](#).

4. Locate the return line exiting of the flex tube and securely connect to the elbow compression fitting in port T.





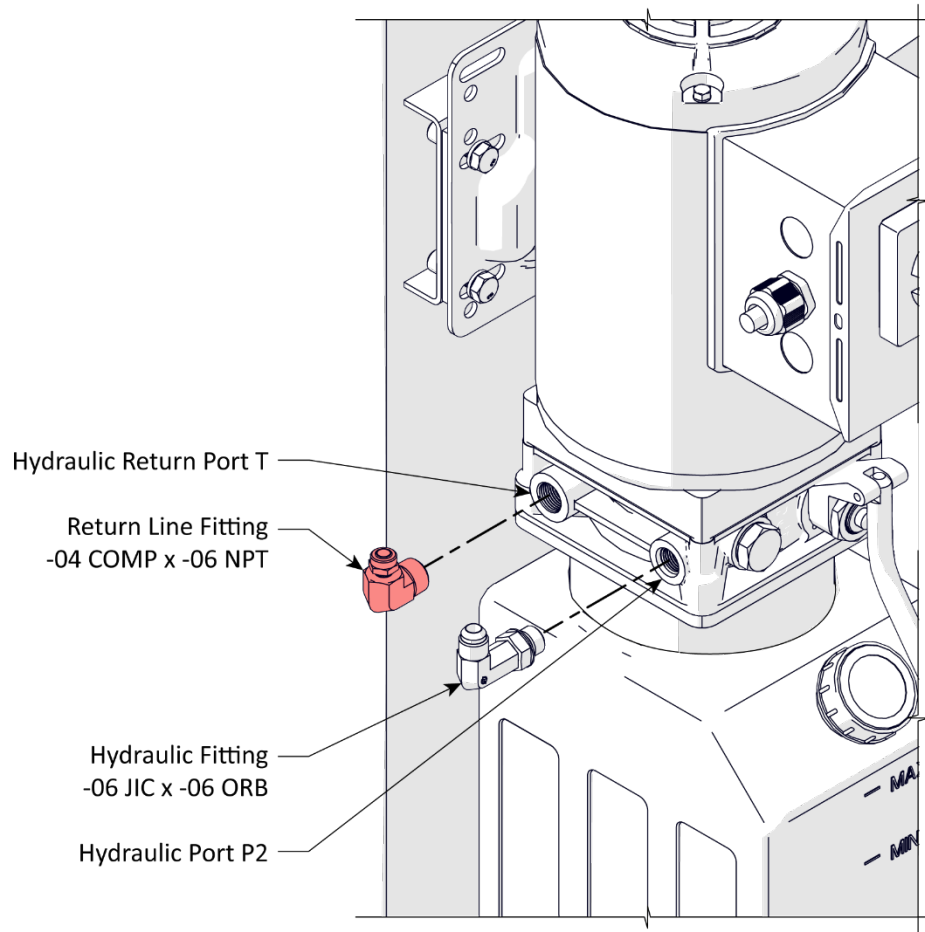





Important: The air line also exits the flex tube and uses the same type of tubing as the return line. The air line should have been connected in the previous section. Ensure you are attaching the return line to the power unit and not the air line. **Do not attach the air line to the power unit.**

Important: The power unit delivered with the Lift may differ from the illustration below. The return port should be labeled T.



Hydraulic System Dangers and Warnings

Before applying power to the hydraulic system, note the following dangers and warnings:

-  **DANGER** Failure to observe these warnings can result in serious personal injury including, in rare cases, death.
-  **DANGER** The power unit is a hydraulic pump capable of developing pressures in excess of 5,000 psi (345 BAR). A pressure relief valve is used to set the pressure at the desired level. Tampering with, adjusting, modifying, or removing the relief valve is extremely dangerous and is not permitted. Only trained Hydraulics technicians are permitted to adjust the relief valve, using calibrated hydraulic pressure gauges to ensure the proper pressure setting is achieved.
-  **DANGER** Changes to the output pressure may render the power unit incompatible with pressure limitations of other components in the hydraulic circuit. This may cause catastrophic failure of those components, and could result in property damage, severe personal injury, or death.
-  **DANGER** The hydraulic system can contain high pressure which, if suddenly released, can cause severe injury or death.
-  **WARNING** The hydraulic hoses and connections **must** be inspected before any attempt to raise a Vehicle is made.
-  **WARNING** **Ensure** all hydraulic hose connections and fittings, including unused auxiliary port plugs on the power unit, the cylinder and anywhere else in the hydraulic system are tightened.
-  **WARNING** Do **not** attempt to connect or disconnect hydraulic Hoses while the equipment is loaded or while a Vehicle is on the Lift or the Hydraulic System is under pressure.
-  **WARNING** Keep bare hands away from hydraulic fluid; always wear gloves when handling hydraulic fluid, Cylinders or Hydraulic Hoses.
-  **WARNING** When handling hydraulic fluid, always observe the manufacturer's safe handling instructions found in their Material Safety Data Sheet (MSDS).
-  **WARNING** **Always** promptly clean any hydraulic fluid spills. If a leak is the source of the spill, lockout the Lift to prevent use until the Hydraulic System is repaired.

Connect the Hydraulic Hose

The hydraulic hose connects routes hydraulic oil from the power unit to the lift cylinder.

One end of the hydraulic hose is already connected to the hydraulic cylinder; the other end should be exiting the flex tube.

To attach the Hydraulic Hose to the Power Unit:

1. Locate the hydraulic port P2 on the power unit and remove the shipping plug.
There are two Hydraulic Output ports on the power unit (P1 and P2); either may be used.
2. Apply a few drops of clean hydraulic fluid or a silicone O-ring lubricant to the O-ring on the ORB fitting.
3. Connect and then securely tighten the ORB fitting into the P2 or P1 port on the power unit. No thread sealant is required.
4. Connect and securely tighten the hydraulic hose exiting the flex tube to the JIC connector on the JIC-to-ORB fitting.

Important: The power unit delivered with the Lift may differ from the illustration below. The hydraulic output ports should be labeled P or P1 or P2.

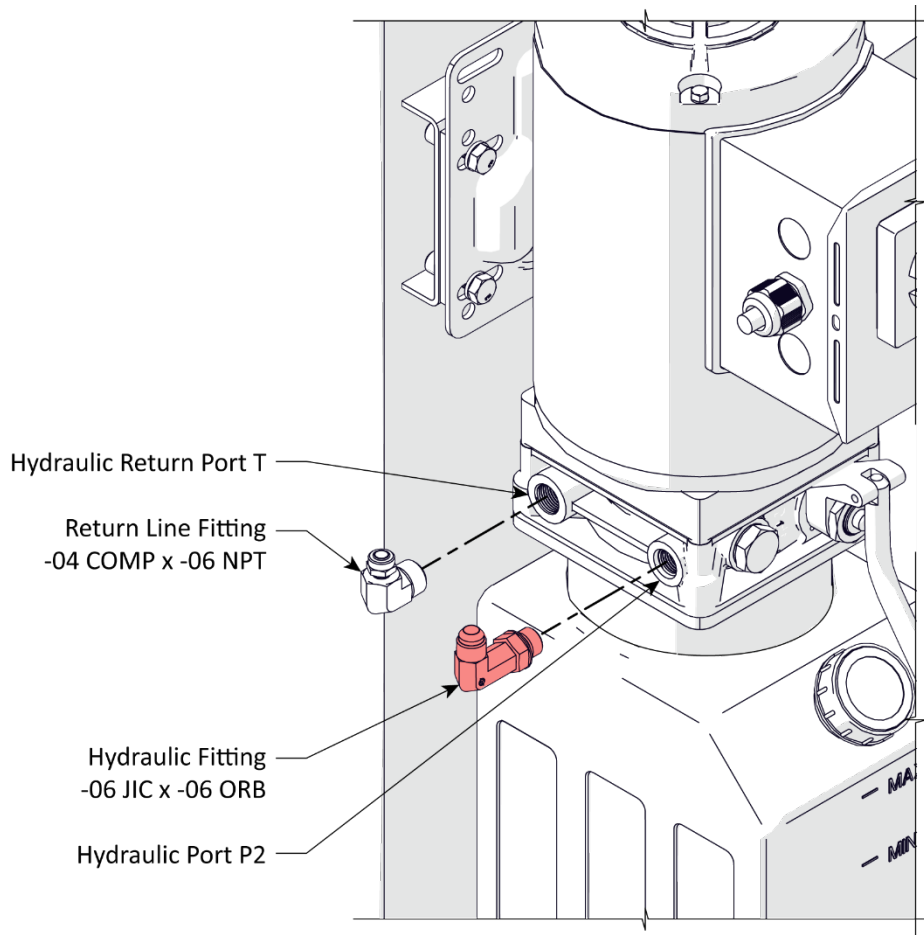

Contact an Electrician

As mentioned previously, there are installation tasks that **require** a licensed Electrician.

⚠ DANGER All electrical wiring **must** be performed by a licensed electrician.

The Electrician is required to:

- **Connect the power unit to the facility power service.** Single phase 208-240 VAC, 30 Amp, 50/60 Hz. is required to power the Lift. Refer to **Connecting the Power Source** for more information.
- **Install a Power Disconnect Switch.** Ensures you can quickly and completely interrupt electrical power to the Lift in the event of an electrical circuit fault, emergency situation, or when equipment is undergoing service or maintenance. The disconnect must be within sight and easy reach of the Lift operator. Refer to **Install a Power Disconnect Switch** for more information.

Install a Thermal Disconnect Switch. The Power Unit supplied with this Lift **does not** include thermal overload protection. Under NEC 430, UL 201, and CSA C22.2 No. 68 intermittent duty motors are not required to include thermal protection. Local electrical codes may vary, and other requirements may exist that the installing electrician will address, if required. Refer to **Install a Thermal Disconnect Switch** for more information.

The Electrician is responsible for providing and installing:

- an appropriate plug or connections to attach to the power unit.
- Appropriate wiring, protected and routed from the power service entrance to the Lift.
- A Thermal Disconnect if required by local electrical codes.

Refer to **Wiring Diagrams** for additional wiring information.

Additional information is supplied in the sections describing these tasks.

Connect the Power Source

The standard power unit for the Lift utilizes a 5HP motor driven at 208-240 VAC, 31 Amps, 50/60 Hz, single phase. The power unit must be connected to an appropriate power source.

Several different power units may be supplied with this Lift. Refer to the power unit's motor for full load amperage and voltage specifications.

Refer to **Wiring Diagrams** in this manual and the wiring diagrams inside the power unit's junction box for current wiring information.

⚠ DANGER All wiring **must** be performed by a licensed electrician. Do not perform any maintenance or installation on the Lift without first making sure that main electrical power has been disconnected from the Lift and **cannot** be re-energized until all procedures are complete. Strict lockout / tagout procedures are to be followed.

Important electrical information:

- Improper electrical installation can damage the power unit motor. Such damage is not covered under the product warranty.
- Use a separate circuit breaker for each power unit.
- Protect each circuit with an appropriately rated time-delay fuse or circuit breaker.

The following figure details typical power unit ports, controls and wiring locations. The unit delivered with the lift may differ.

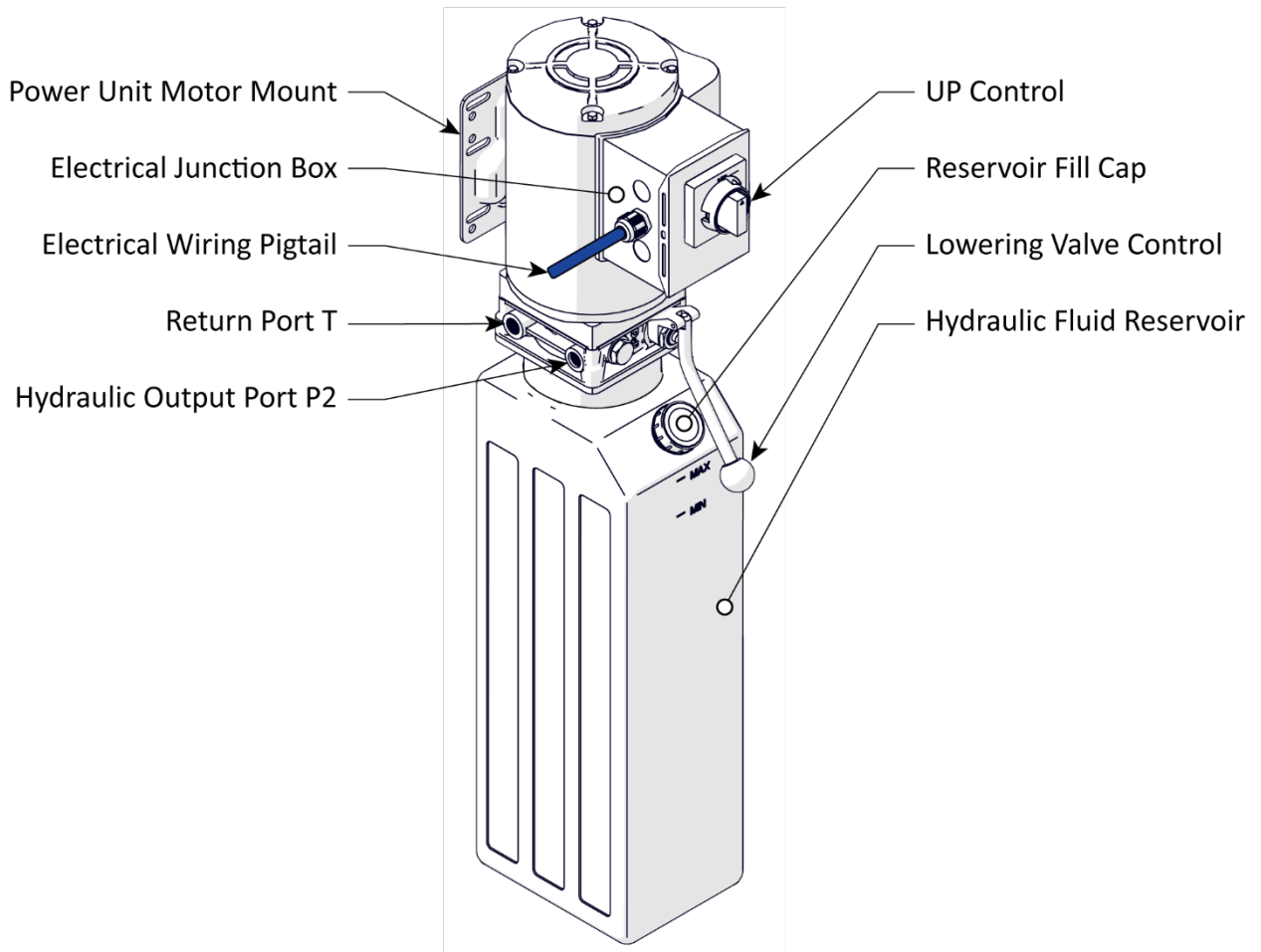

To connect the power unit to a power source:

1. Locate the pigtail exiting the electrical junction box on the power unit.
2. Open the junction box and remove the pigtail.
3. Choose one of the options below:
 - a. Wire the power unit directly into the facility’s electrical system through a disconnect and thermal disconnect (if required).
 - b. Wire a power cord with an appropriate plug. The power cord and plug are **not** supplied with the Lift.

See [Wiring Diagrams](#) for wiring information.

4. Close the electrical junction box.
5. Double check to ensure the hydraulic fluid reservoir has an adequate supply of fluid.

The hydraulic fluid reservoir holds approximately 7 gallons (26.5 liters), depending on the power unit delivered.

⚠ WARNING Do not run the Lift with insufficient hydraulic fluid; this will damage the Power Unit.

Installing a Power Disconnect Switch

⚠ WARNING A main power disconnect switch is **not** provided with this equipment.

A power disconnect switch is required by the National Electrical Code (NEC). They are designed to interrupt electrical power in the event of an electrical circuit fault, emergency situation, or when equipment is undergoing service or maintenance.

The Electrician is to install a power disconnect switch that is properly rated for the incoming voltage and current.

⚠ DANGER All wiring **must** be performed by a licensed electrician.

Your power disconnect switch must be readily accessible and installed so that it is in easy reach of the Lift operator. It must be clearly and legibly marked to indicate its purpose.

The figure to the right shows a power disconnect switch between the Lift's power source and its Power Unit. A quick flip of the switch immediately cuts power to the Lift.

A licensed Electrician is required to select and install the power disconnect switch.

Make sure the Electrician selects a UL-listed power disconnect switch.

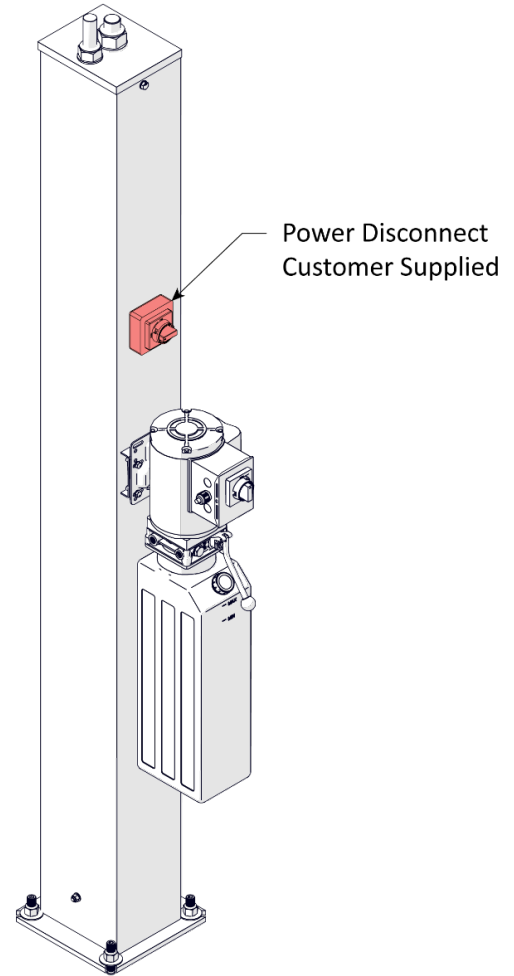

⚠ WARNING Ensure the power switch mounting fasteners will not strike, damage or otherwise interfere with the internal Lift components.

Installing a Thermal Disconnect Switch

The Power Unit supplied with this Lift **does not** include thermal overload protection. Under NEC 430, UL 201, and CSA C22.2 No. 68 intermittent duty motors are not required to include thermal protection. Local electrical codes may vary, and other requirements may exist that the installing electrician will address, if required.

⚠ DANGER If local electrical codes require the installation of a thermal disconnect, the disconnecting device and the installation **must** be provided by a licensed electrician in accordance with local electrical codes. Do not perform **any** maintenance or installation on the Lift without first verifying that main electrical power has been disconnected from the Lift and **cannot** be re-energized until all procedures are complete.

High running amperage that exceeds the motor's full load amperage (FLA) rating may result in permanent damage to the motor. **Never** exceed the rated duty cycle of the Lift's motor.

Anchor the Posts

If you have not done so already, you need to anchor the Lift's four Posts. Install one Anchor Bolt in each corner of each Base Plate, 16 Anchor Bolts total.

HDS-18 Concrete specification *minimum* requirements:

- **Depth:** 4.25 in. (108 mm)
- **PSI:** 3,000 PSI, minimum
- **Cured:** 28 days, minimum
- **Reinforcement:** Welded wire mesh, minimum

HDS-27 and HDS-40 series concrete specification *minimum* requirements:

- **Depth:** 6.5 in. (165 mm) minimum
- **PSI:** 3,000 psi (207 kPa) minimum
- **Cured:** 28 days, minimum
- **Reinforcement:** Welded wire mesh, minimum

Anchor Bolt specifications:

- **Length:** 4.75 in. (121 mm)
- **Diameter:** .75 in. (19 mm)
- **Effective embedment:** 2.75 inches, minimum
- **Anchor torque:** 85-95 ft lb. (115 Nm) (do *not* Torque less than 80 or more than 105)

 **WARNING** The concrete and anchor bolts ***must*** meet these specifications. Only install your Lift on a concrete surface. If a Lift is installed on asphalt or any other surface, or the concrete or anchor bolts do not meet these specifications, it could lead to product damage, vehicle damage, personal injury, or even loss of life. BendPak Lifts are supplied with installation instructions and concrete fasteners meeting the criteria as prescribed by the American National Standard "Automotive Lifts – Safety Requirements for Construction, Testing, and Validation" ANSI/ALI ALCTV.

 **WARNING** Use only the Anchor Bolts delivered with this Lift. If components are used from a different source, the warranty is void and the safety of everyone who installs or operates the Lift is compromised.

 **WARNING** Lift buyers are responsible for conforming to all regional, structural, and seismic anchoring requirements specified by any other agencies and/or codes, such as the Uniform Building Code and/or International Building Code.

To anchor the Posts:

1. Locate the fasteners required: four anchor bolts, four nuts, and four washers for each lift post.
2. Using the base plates as guides, drill the holes for the anchor bolts—one hole in each corner of the base plate.

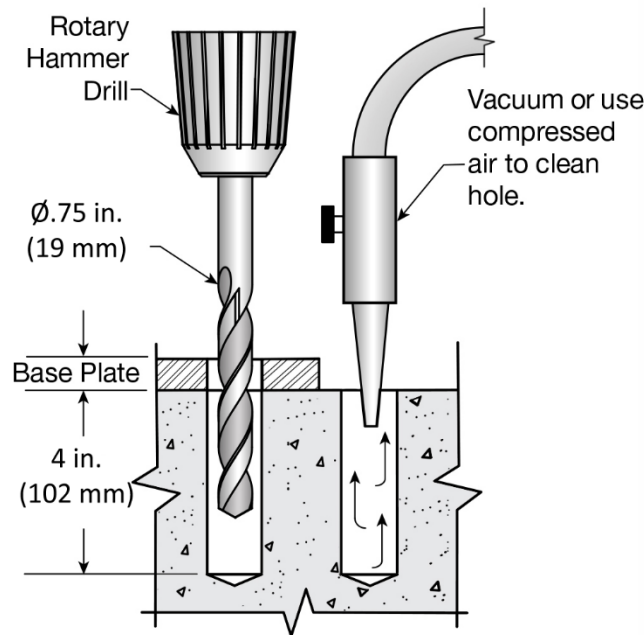

Drill straight into the concrete, in the center of the slot. Do not let the drill wobble side to side. Use a carbide bit designed for drilling concrete (conforming to ANSI B212.15).

The diameter of the drill bit must be the same as the diameter of the Anchor Bolt. If a 3/4 inch diameter Anchor Bolt is being installed, use a 3/4 in. (19 mm) diameter drill bit.

Important: Do **not** drill all the way through the concrete. Punching completely through the slab compromises the holding strength of the anchor bolt once they are put into place.

3. Vacuum each hole clean.

Thoroughly clean each drilled hole.

BendPak recommends using a vacuum to clean the opening. A wire brush, hand pump, or compressed air may also be used.

Do **not** ream the hole. Do **not** make the hole any wider than the drill bit made it.

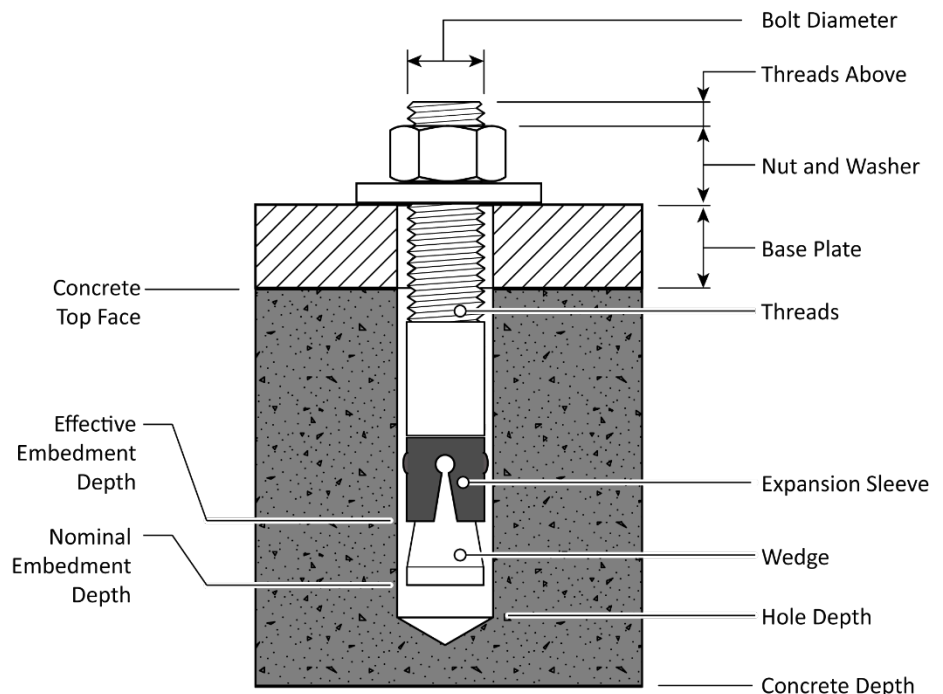

Important:

The holding strength of an anchor bolt is partially based on the how cleanly the expansion sleeve presses against the concrete. If the hole is filled with dirt or drilling grit, the expansion sleeve will not press against the concrete cleanly, reducing the holding strength. If the hole is too wide, the expansion sleeve does not press against the concrete with as much force, again resulting in a reduction in holding strength.

4. Ensure the washer and nut are in place, then insert the anchor bolt into the hole.

The expansion sleeve of the anchor bolt may hinder its passing through the hole in the base plate; this is normal. Use a hammer or mallet to tap the expansion sleeve through the base plate and into the hole.

Even using a hammer or mallet, the anchor bolt should only move into the hole part of the way; this is normal. If the Anchor Bolt drops all the way in with little or no resistance, the hole is too large.

Once past the hole in the base Plate, the anchor bolt will eventually stop moving down into the hole as the expansion sleeve contacts the sides of the hole; this is normal.

5. Hammer or mallet the Anchor Bolt the rest of the way down into the hole.

Stop when the Washer is snug against the Base Plate.

6. Plumb each Post; install any needed Shims.

Do not shim a Post more than half an inch using the provided Shims. A maximum of 2 in. (51 mm) is possible by ordering optional Shim Plates. Contact BendPak at **(800) 253-2363** then follow the prompts to order shim plates. Please have the model and serial number of your Lift available.

Take your time while plumbing and shimming the Posts; ***it is important to make the Lift level as possible.***

7. Wrench each nut ***clockwise*** to the recommended installation torque, 85-95 ft lb. (115 Nm), using a torque wrench.

Wrenching the Nut forces the Wedge up, forcing out the Expansion Sleeve and pressing it tightly against the Concrete.

Important:

Never use an impact wrench to tighten the anchor bolts. Using an impact wrench creates a risk of fracturing the surrounding concrete and anchor failure.

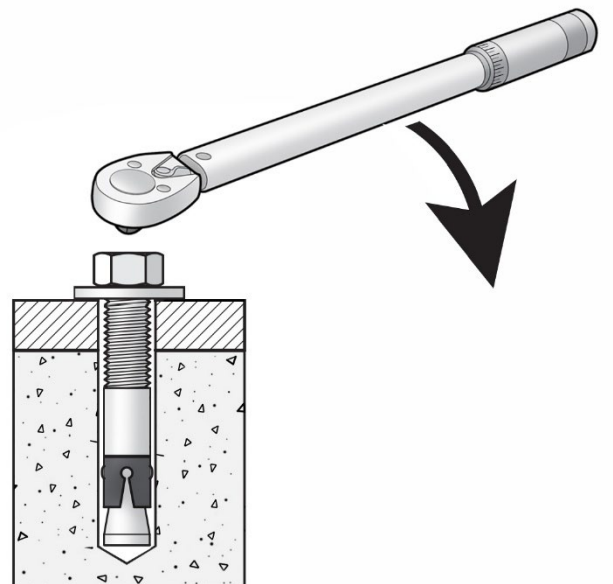
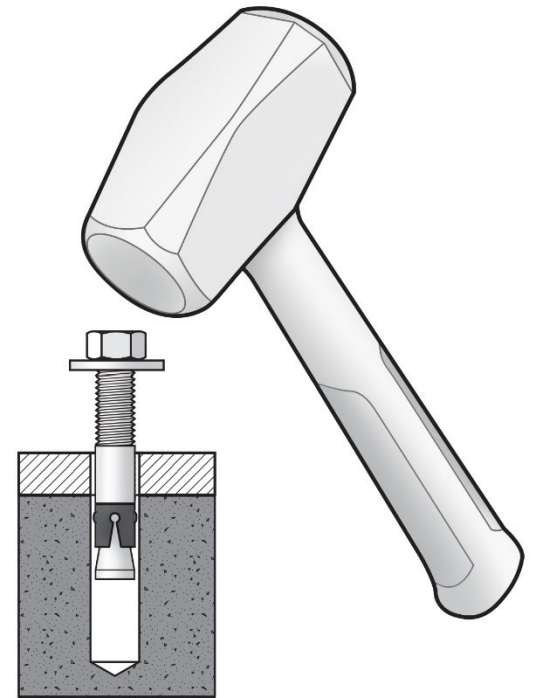

Final Leveling

It is particularly important that the Lift's runways are level, or as close to level as possible. The following procedure describes how to correct an out of level condition.

Tools Required: four-foot level, step ladder, and open-end wrenches.

To complete the final runway leveling:

1. Raise the Lift runways and then lower onto the first safety lock position.
2. Verify both ends of both Crosstubes are resting *on the same safety lock*, measured from the bottom on all four lift posts.
3. Use a level to verify the runways are flat *before* attempting to adjust the cables.
 - a. If a runway requires adjustment for an out of level condition, use a wrench to loosen the jam nut on the safety ladder under the top cap. Adjust the safety Ladder up and down using the ladder adjustment nut on top of the lift post as required to achieve a level runway.
 - b. Once level, tighten the jam nut under the top cap and verify the ladder adjustment nut is snug against the top cap as well.

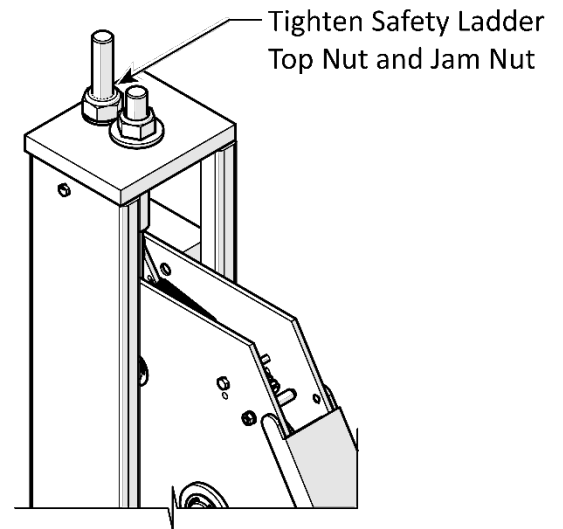

IMPORTANT! Do *not* stand on the runways while checking for out of level conditions.

Lift Cable Adjustment Procedure

This procedure is intended to adjust the safety lock engagement and disengagement to compensate for cable stretch. Important rules to remember about lift cables:

- All lift cables stretch over time; therefore, all lift cables will require occasional adjustment.
- Longer lift cables stretch more than shorter cables.
- All vehicles are unique and will stretch some cables more than others based on vehicle weight distribution.

Tools Required: Step ladder and open-end wrenches.

IMPORTANT! Do *not* stand on the runways while checking or adjusting the lift cables.

To adjust the Lift Cables:

1. Verify the threaded end of the lift cable is secured to the top cap on each lift post.
2. Ensure all four cables are under slight tension. No slack should be present anywhere in the system.
3. Use a ladder to access the top of the lift post. Do *not* stand on the runway while adjusting the lift cables.
4. Loosen the lift cable adjustment and jam nuts. Adjust all four cables until the top of the crosstube is even with the bottom of the ladder cutout on each lift post. Refer to the figure on the next page.

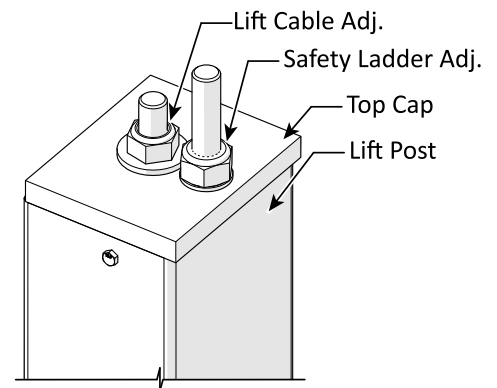

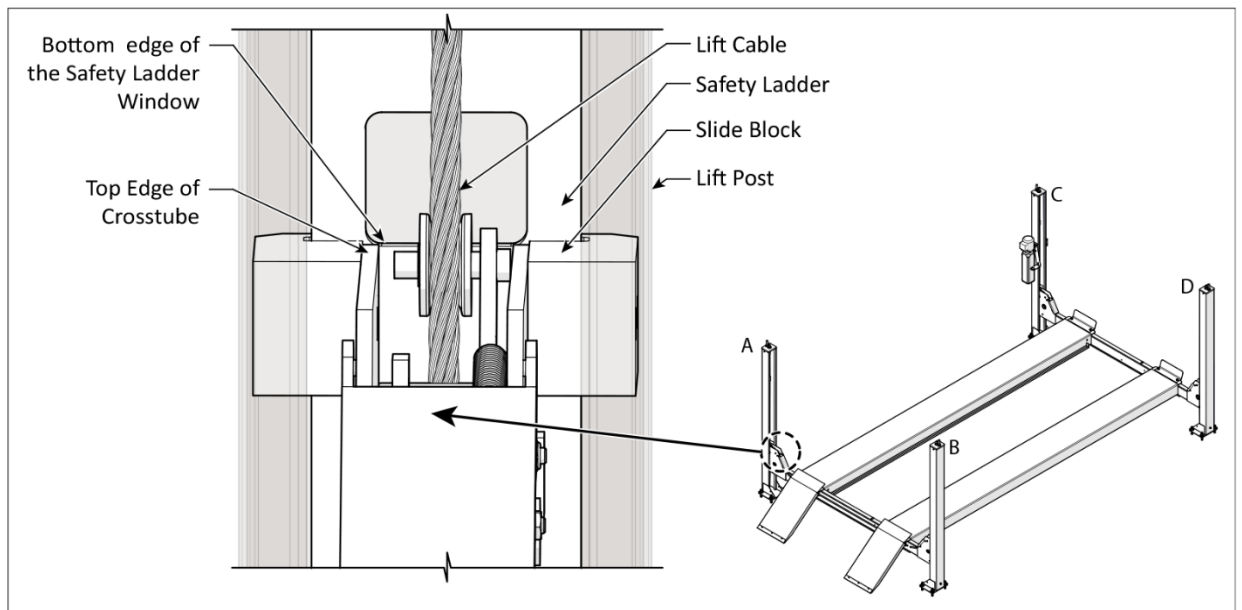

5. Identify the Lift Posts A through D based on increasing cable length. Refer to the figure below.
6. A slight increase in the Crosstube position will approximate the typical initial cable stretch. Adjust the distance from the top of the Crosstube to the bottom of the safety ladder window as listed below:
 - Post A (shortest cable) should be even with the bottom of the safety ladder cutout.
 - Post B should measure 1/16 in. (1.5 mm) above the safety ladder cutout.
 - Post C should measure 1/8 in. (3.1 mm) above the safety ladder cutout.
 - Post D (longest cable) should measure 3/16 in. (4.7 mm) above the safety ladder cutout.
7. Tighten the lift cable and jam nuts to secure them in place.
8. Raise and then lower the lift runways while listening for the safety latch engagement and observing all four corners to verify the Lift is descending evenly. If one corner is not descending, stop the Lift immediately and refer to **Troubleshooting** before proceeding.
 - a. If all of the safety locks are engaged at the same time, no further lift cable adjustment is required. Move to step 9.
 - b. If one or more safety locks are delayed significantly later than the others (1 second or more), then note the late lock position(s) and stop the Lift.
 - Lower the Lift onto the nearest safety lock ladder cutout.
 - Verify all four Safety Locks are resting on a safety lock cutout.
 - Tighten the lift cable on the safety lock positions that engage late.
 - Secure the lift cable by tightening its jam nut and repeat the procedure from step 8 until all safety locks engage the safety ladder cutout roughly at the same time.
9. Lower the runways to the ground only when it is safe to do so!
10. Carefully drive a vehicle onto the runways. Have the help of an assistant to verify the vehicle is centered on the runways and the Lift.
11. Put the vehicle into park (first or reverse gear, if a manual transmission).
12. Set the parking brake and exit the vehicle.

-
13. Chock the wheels.
 14. Raise the Lift runways while listening for the safety locks to engage the ladder cutouts.
 - a. If all of the Safety Locks are engaging at the same time, no further lift cable adjustment is required. Move to step 15.
 - b. If one or more Safety Locks are delayed significantly later than the others (1 second or more), then note the late lock position(s) and stop the Lift.
 - o Lower the Lift onto the nearest Safety Lock Cutout.
 - o Verify all four Safety Locks are resting on a Safety Lock Cutout.
 - o Tighten the Lift cable on the Safety Lock position(s) that engage late.
 - o Secure the Lift cable by tightening its Jam Nut and repeat the procedure from step 14 until all Safety Locks engage the Safety Ladder Cutout at roughly the same time.
 15. Lower the runways to the ground when it is safe to do so.
 16. ***When the Lift runway is level and the safety locks are all engaging roughly the same time, verify the ladder nut, the lift cable and its jam nuts are all securely fastened at the top of each lift post.***

Install the Accessories

The accessories included with this Lift include:

- **Tire Stops.** Installed at the Front of the Lift. Hold the front Tires of the vehicle in position. BendPak recommends chocking the rear Tires, so that the vehicle stays in place.
- **Ramps.** Installed at the Rear of the Lift. Allow vehicles to be easily driven onto the runways.
- **Anti-Slip Tape.** Installed on the platforms to improve traction.

Tire Stops

Tire Stops are bolted onto the front of each runway. They prevent the tires of the vehicle from moving too far forward.

To install the Tire Stops:

1. Retrieve the components listed in the table below from the parts box and the parts bag.

Item	Part Number	Description	Qty.
1	5530080	M20 x 60 Hex Head Bolt	4
2	5545343	M20 Flat Washer	4
3	5535017	M20 Hex Nut, Nyloc	4
4	5620194	Tire Stop Weldment	2

2. Place one tire stop in position over the openings in the runway. Refer to the figure below.
3. Assemble the bolt and flat washer then insert into the tire stop bolt holes and push through the runway.
4. Thread the hex nut onto the bolt extending through runway. Secure by tightening the hex nut.
5. Repeat Steps 1 through 4 for the second tire stop.

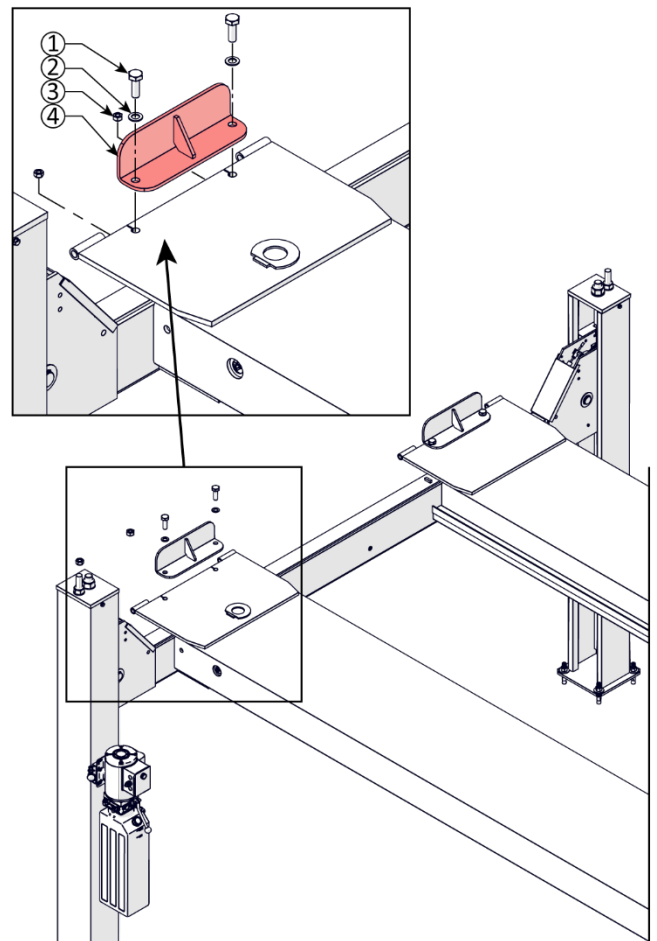

Drive-Up Ramps

The Lift is delivered with two drive-up ramps, which are installed onto the rear of the Lift, allowing vehicles to drive onto the runways.

To install the Ramps:

Note: The drive-up ramps are heavy and awkward to handle. Two people should work together to install the Ramps.

1. Retrieve the required components for the Lift being assembled as listed in the tables below.

HDS-18/27 Series Drive-Up Ramps			
Item	Part Number	Description	Qty.
1	5505123	HDS-18/27 Drive-Up Ramp Pin (parts box)	2
2	5505032	18mm Rotor Clip (parts bag)	4
3	5215161	HDS-18/27 Extended Drive-up Ramp Assembly	2

HDS-40 Series Drive-Up Ramps			
Item	Part Number	Description	Qty.
1	5505129	HDS-40 Drive-Up Ramp Pin (parts box)	2
2	5505032	18mm Rotor Clip (parts bag)	4
3	5215162	HDS-40 Extended Drive-up Ramp Assembly	2

2. Position a ramp on the end of a runway at the rear of the Lift. The tube on the bottom of the ramp should be positioned between the two tubes at the end of the runway. Refer to the figure below.
3. Slide a ramp pin through the tubes.
4. Install rotor clips on both ends of the ramp pin to secure it in place.
5. Repeat steps 2 through 4 for the remaining drive-up ramp.

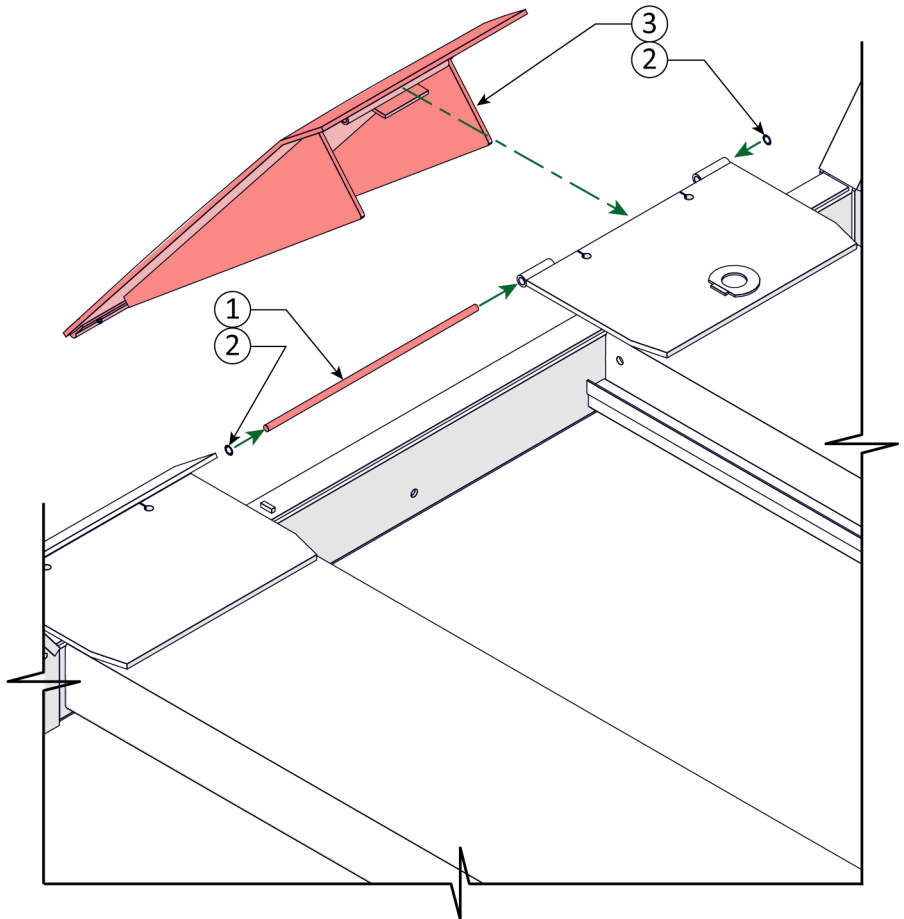

Applying Anti-Slip Tape

The anti-slip tape (SKU 5930195) is provided in a single roll measuring 6 in. x 24 ft. (152 mm x 7.3 m). BendPak suggests cutting the tape into several equal lengths.

IMPORTANT! Surface preparation is important. If the runway is in poor condition with gouges, holes, or jagged edges the anti-slip tape will not adhere. Lift runways must be clean, dry, and smooth.

To apply the Anti-Slip Tape:

1. Clean the runway. Use a broom or brush to remove loose dirt and debris from the runway.
2. Thoroughly wash, rinse, and dry the runway using a mild solution of soap and clean water to remove any oils, grease, and water-soluble contamination. Dry the runway with a clean cloth and allow to air dry.
3. Cut the anti-slip tape into equal pieces.
4. Verify the runway is dry and clean. It is critical for maximum adhesion of the anti-slip tape that the runway be dry, free of dirt, oils, and grease.
5. Measure and mark the runways with pencil guidelines to outline the tape installation area on the ramp. Refer to the figure on the next page for a suggested layout of the anti-slip tape.

IMPORTANT! Do not install this tape directly on the edge of a runway. Stay at least 1 in (25 mm) away from edges. Do not attempt to bend this tape over an edge.

6. Wash your hands. The anti-slip tape's adhesive side is protected by a paper or plastic film. You will remove this film a few inches at a time to apply the tape to the runway.

IMPORTANT! Handle the tape by its edges. Minimize contact between the adhesive and your hands. The oils from your hands will reduce the adhesive's long-term effectiveness.

IMPORTANT! BendPak recommends two people work together to install the tape. One person removes the backing and applies the tape to the runway while the second holds the tape in place over the guidelines marked on the runway.

7. Lay one piece of the anti-slip tape on the runway and peel back about 2 in. (50 mm) of the protective film. Apply the adhesive side to the runway inside the guidelines you created in step 5.
8. Slowly remove the film as you press the exposed tape's adhesive side into the runway. Work slowly and apply 2 to 5 in. (51 to 127 mm) at a time to stay within your guidelines.
9. After applying the tape use a heavy rubber roller to press the tape into the runway and to ensure firm contact with the adhesive.
10. Apply the anti-slip tape to the remaining area of the Lift's runways.

Lubricate the Lift Prior to Operation

There are several lubrication points on the Lift.

- **Inside of the Lift Posts.** Lubricate the inside of the lift posts in the slide block contact area with a white lithium grease.
- **Lift Cables / Wire Rope** is only fully protected when each wire strand is lubricated both internally and externally. Excessive wear shortens the life of wire rope. Use a wire-rope lubricant that penetrates to the core of the rope and provides long-term lubrication between each individual strand, such as 90-WT gear oil or ALMASOL® Wire Rope Lubricant. To make sure that the inner layers of the rope remain well lubricated, lubrication should be done at least every three months during normal operation.
- **All Sheaves and Sheave Bearings** that contact moving wire rope should be given regular visual checks for surface wear and lubricated to ensure they run freely. This should be done every three months during normal operation.

For all sheave pins and bearings, use standard wheel bearing grease red lithium or equal heavy lubricant, applied by any method including pump/spray dispensing, brush, hand, or swabbing. The following graphic details the lubrication points on the Lift.

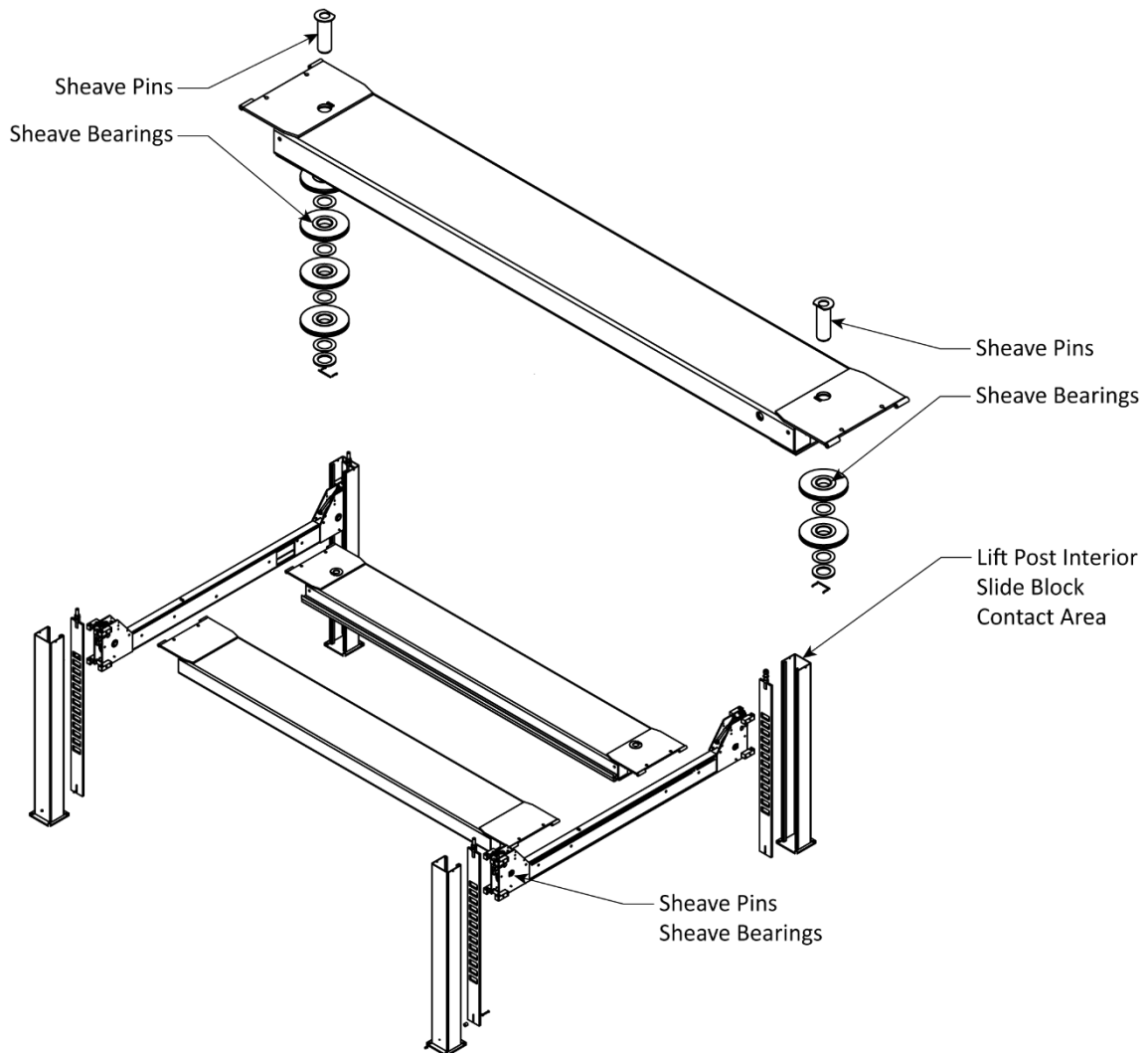

Bleed the Hydraulic Cylinder

The hydraulic cylinder on the Lift is self-bleeding, which means that in most cases any air in the system can be removed by raising and lowering the runways a few times; “bleeding” the hydraulic system of the unwanted air.

⚠ WARNING Before performing any maintenance on your Lift (for example, bleeding the hydraulic cylinder or adding hydraulic fluid), ensure both runways are on the ground and the power source has been disconnected.

Symptoms of air in the hydraulic system include runways moving erratically and/or making odd noises. These could be caused by other situations; refer to **Troubleshooting** for more information.

To bleed the Hydraulic System:

1. Raise and lower the runways up to six times; ***pause for at least one minute between each cycle.***

The Lift’s motor cannot run continuously; it is designed for regular use, but not continuous use.

2. Watch the runways as you raise and lower them.

When the Lift stops moving erratically or stops squeaking, you can stop the bleeding process.

3. Check the hydraulic fluid reservoir on the Power Unit.

Bleeding the Hydraulic System may significantly lower the amount of hydraulic fluid in the reservoir.

4. Add additional hydraulic fluid if necessary.

If your Lift is still moving erratically or making odd noises after bleeding the Hydraulic System, refer to **Troubleshooting** for more information.

Perform an Operational Test

BendPak strongly recommends doing an Operational Test of your Lift with a typical vehicle before starting normal service (a typical vehicle is not required but is recommended).

During the Operational Test, watch the Lift and its components and check for proper installation and operation. If you run into an issue that does not go away, refer to **Troubleshooting** for more information.

Note: Residual air in the Hydraulic System can cause the Lift to shake, move erratically, or squeak when you start using it; this is normal. If it happens, do not worry; it will go away as the Hydraulic System is self-bleeding. If it does not go away soon, try bleeding the Cylinder of air. If it still does not go away, refer to **Troubleshooting** for additional information.

To test your Lift:

1. Check the area around, above, and under the Lift for obstructions; move them if you find any.
2. Drive the vehicle onto the Lift. Try to center the vehicle’s tires in the middle of each runway.

Put the vehicle into park, engage the parking brake, put it in gear if it is a manual transmission, and chock the wheels.

3. Press and hold the Up button.

Both runways start rising.

4. After the runways pass one or two Safety Locks (you will hear them), release the Up button. The runways stop rising.

-
5. Press and hold the pushbutton on the pushbutton air valve, then press and hold the Lowering Handle.
The runways start lowering.
 6. When the runways get to the ground, release the Lowering Handle.
 7. Wait for one minute.

 **CAUTION** Always take a break between cycles. The Power Unit's motor is **not** constant duty; it cannot be run continuously.

8. Repeat the process, this time raising the runways to a higher Safety Lock.
9. If the Lift is working without shaking, moving erratically, or squeaking, there is no need to repeat the procedure.

If the Lift is shaking, moving erratically, or squeaking (which is normal during the start-up period), repeat the procedure a couple more times, with at least a one-minute break between cycles.

If you continue to have issues, refer to **Troubleshooting** for assistance.

Final Checklist Before Operation

Make sure these things have been accomplished **before** putting the Lift into service:

- Review the **Installation Checklist** to make sure all steps have been performed.
- Make sure the Power Unit is getting power from the power source.
- Check the hydraulic fluid reservoir on the Power Unit; it must be full of approved hydraulic fluid or automatic transmission fluid. **You can damage the motor by running it without enough fluid.**
- Check the Hydraulic System for leaks.
- Make sure all four Posts are properly anchored, shimmed, level, and stable.
- Make sure all cables are properly seated in their sheaves.
- Make sure all Safety Locks are operating normally.
- Make sure the backup Slack Safety Locks are **not** engaged.
- Make sure a copy of the *Installation and Operation Manual* is left with the Lift.
- If it has not been done already, perform an Operational Test of the Lift with a typical vehicle. Refer to **Performing an Operational Test**.
- Deliver the *Installation and Operation Manual* to the owner/user/employer along with the other instructional materials furnished with the lift.



Operation

This section describes how to operate your Lift.

Safety Considerations

Do the following every time **before** you raise a vehicle on your Lift:

- **Check the Lift.** Walk all the way around the Lift, checking for any missing, heavily worn, or damaged parts. Do not operate the Lift if you find any issues; instead, take it out of service, then contact your dealer, email support@bendpak.com, or call **(800) 253-2363**.
- **Check the area.** Keep the area around and under the Lift clean and free of obstructions; anything that could cause a problem. Do not forget to check **above** the Lift. If you find an obstruction, move it out of the way. If you find any other issues, resolve them before using the Lift. Do not allow any people or animals within 30 ft. (9 m) of the Lift while it is in motion.
- **Check the operators.** Make sure everyone who is going to operate the Lift has been trained in its use, has read the labels on the unit, and has read the manual. Only the operator at the Controls should be within 30 ft. (9 m) of the Lift when it is in motion.

Do not allow children to operate the Lift. Do not allow anyone under the influence of drugs, alcohol, or medication to operate the Lift. Do not allow any unauthorized personnel to operate the Lift.

- **Check for safety.** Make sure everyone who is going to be walking near the Lift is aware of its presence and takes appropriate safety measures. Only put vehicles on the runways.

When raising a vehicle, do not leave it until it is engaged on a Safety Lock. When lowering the Lift, do not leave it until it is on the ground.

- **Check the vehicle.** Never exceed the Lift's weight rating. Do not allow people inside a vehicle you are going to raise. Make sure the vehicle is not overbalanced on either end or either side.
- **NEVER** park any vehicle on the Lift's runways without placing two suitable wheel chocks behind each rear tire so that the vehicle cannot roll off the Lift. Vehicles parked on Lift **MUST** also be placed in Park or First Gear (Manual Transmission) with the Parking Brake fully applied.
- **Always ensure the vehicle wheels are placed in the usable areas of the runways. See the figure on the following page.**

Usable Area

The strength of the runway is reduced in its middle. Do **not** place the wheels of a vehicle in this area. The same restriction applies to Rolling Jacks and Bottle-Jack Trays. They must **not** be used in the middle section of the runways. This will not impact the use of the Lift in most cases, as the wheelbase length of most vehicles put the wheels in the usable areas.

⚠ CAUTION Do not load Vehicles so that the wheels are in the middle 30% of the runways or use Rolling Jacks or Bottle-Jack Trays in that area; it could permanently damage the runways. Damage caused by this **unsupported** use of the Lift is **not** covered under Warranty.

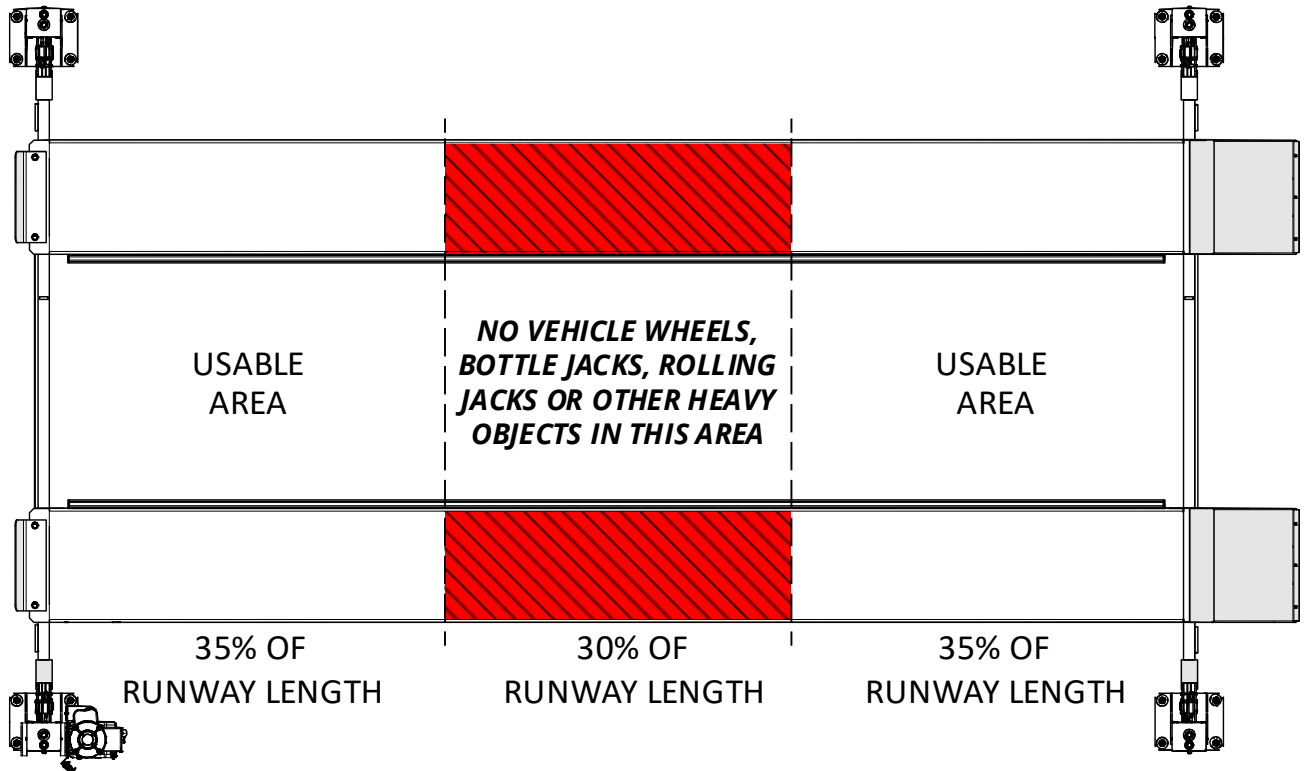

	HDS-18E	HDS-27	HDS-27X
Min. wheelbase at 100% capacity	185 in. (4,699 mm)	180 in. (4,572 mm)	225 in. (5,715 mm)
Min. wheelbase at 75% capacity	155 in. (3,937 mm)	155 in. (3,937 mm)	195 in. (4,953 mm)
Min. wheelbase at 50% capacity	130 in. (3,302 mm)	130 in. (3,302 mm)	160 in. (4,064 mm)
Min. wheelbase at 25% capacity	105 in. (2,667 mm)	105 in. (2,667 mm)	130 in. (3,302 mm)

	HDS-40	HDS-40X	HDS-40FL
Min. wheelbase at 100% capacity ²	180 in. (4,572 mm)	225 in. (5,715 mm)	140 in. (3,556 mm)
Min. wheelbase at 75% capacity ²	155 in. (3,937 mm)	190 in. (4,826 mm)	120 in. (3,048 mm)
Min. wheelbase at 50% capacity ²	130 in. (3,302 mm)	160 in. (4,064 mm)	100 in. (2,540 mm)
Min. wheelbase at 25% capacity ²	105 in. (2,667 mm)	130 in. (3,302 mm)	80 in. (2,032 mm)

Using the Controls

The Controls for the Lift include:

- **Up button.** Press and hold to raise the runways. Located near the top of the Power Unit.

To put runways onto a Safety Lock position: Raise the runways a little above where you want them, then press and hold the Lowering Handle to back the runways down onto the Safety Locks position (do not press and hold the pushbutton on the pushbutton air valve). When the runways stop moving downward, they are engaged on a safety lock.

Before leaving the Lift, make sure all four corners are engaged on their Safety Locks.

- **Lowering Valve Handle.** Press and hold to lower the runways. Located in the middle of the power unit, the lowering valve handle is long and includes a ball-shaped knob at the end.

Always watch the runways closely as they descend to ensure they are moving downward evenly. If they are not, stop lowering the Lift and troubleshoot the problem.

⚠ WARNING: Only leave the Lift engaged on all four safety locks or fully lowered.

- **Pushbutton Air Valve.** Press and hold the pushbutton on the pushbutton air valve as part of the process to lower the runways. Located on one side or the other of the Power Unit (depending on where it was installed). Pressing and holding the pushbutton on the pushbutton air valve disengages the safety locks, which is required to lower the runways.

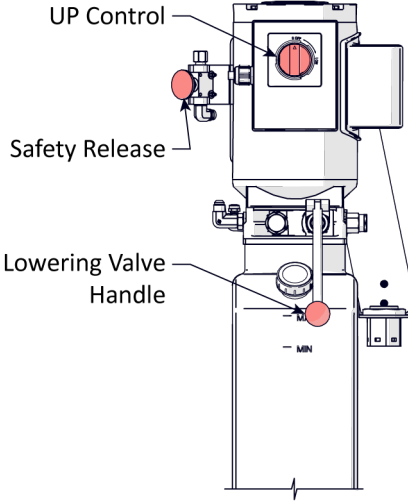
<p>To raise runways to a Safety Lock:</p> <ol style="list-style-type: none">1. Rotate and hold the UP Control.2. When just past desired height, release Up Control.3. Press and hold Lowering Valve Handle.4. Runways will stop moving downward when engaged on all four safety locks; release the lowering handle when they stop. <p><i>Do not press and hold the Safety Release Pushbutton.</i></p>		<p>To lower runways:</p> <ol style="list-style-type: none">1. Rotate and hold the UP Control for a couple of seconds to move the Lift off the safety locks.2. Press and hold the Safety Release Pushbutton.3. Press and hold the Lowering Valve Handle. Runways begin to lower.4. When runways are fully lowered, release the Pushbutton and Lowering Valve Handle.5. Drive vehicle off the runways when safe.
---	---	---

Raising and Lowering Vehicles

Keep the following in mind when operating your Lift:

- **Be safe.** Make sure to check for people, pets, and objects that might be in the path of the Lift as it raises and lowers. If there is something in the way, stop the Lift and move it out of the way. Watch the Lift carefully as it ascends and descends.

 **DANGER** Pay careful attention when you are raising or lowering the Lift. If a person or pet becomes stuck under the Lift, they could be injured or, in rare cases, killed. If a problem arises, either stop the Lift or get it back to the ground, whichever is safest.

- **The Power Disconnect Switch is there for a reason.** If something unexpected occurs, use the **Power Disconnect Switch** to immediately stop the Lift from moving.
- **Remove the materials needed from the vehicle before lifting it.**
- **Never raise the Lift with people in the vehicle.**
- **Make sure the vehicle is balanced.** If there is extra weight on one end or the other, remove it or balance it before raising the vehicle.
- **Center the vehicle's wheels on the runway.** Centered wheels keep the vehicle balanced.

To raise a vehicle:

1. Make sure the runways are on the ground. If they are not, move them down to the ground.
2. Drive a vehicle onto the runways.
3. Ensure all four wheels rest fully on the runways, as close to the center of the runways as possible. Put the vehicle into park and engage the parking brake. If the vehicle has a manual transmission, make sure it is in first gear or reverse, not neutral.
4. Chock the tires.
5. Rotate the **Up** control on the power unit.
The runways will begin to rise.
6. When the runways approach the desired height, continue up a little bit more, then release the **Up** control.
7. Press and hold the lowering valve handle until the runways engage on the closest set of four safety locks.

If one of the four Safety Locks fails to engage, the non-engaged corner of the Lift will continue to descend, while the others stay on their locks. This results in a runway that is not flat. Always ensure that all four Safety Locks are engaged; you know they are if both runways are completely flat. Stop lowering and raise the Lift. Troubleshoot to determine the cause of the failure.

 **WARNING:** Only leave the Lift either engaged on all four safety locks or fully lowered.

8. With the runways engaged on all four Safety Locks, check around and under the vehicle to ensure the area is safe. If anything is wrong, fix it before anyone gets near the runways or moves under them.

To lower a vehicle:

⚠ DANGER *Pay close attention while lowering the Lift! Verify all four corners are descending evenly!* If one corner remains on its safety lock while the other three corners descend, **stop lowering immediately** and raise the lift runways to return them to where all four locks are engaged at the same height. Refer to the **Troubleshooting Section**.

1. Double check that no one except the lift operator is within 10 ft. (3 m) of the Lift.
2. Rotate the **Up** control to disengage the runways from the safety locks. After a second or two, release the **Up** control.
3. Press and hold the Safety Release Pushbutton **and** the Lowering Valve Handle *at the same time*.
4. If all four corners of the Lift are descending evenly, bring the runways all the way to the ground, then release the Safety Release Pushbutton and the Lowering Valve Handle.
5. Remove the Tire Chocks, then carefully drive the vehicle off the runways.

Maintenance

 **DANGER** Before performing any maintenance on your Lift, make sure it is completely disconnected from power.

To maintain your Lift:

- **Daily:** Keep the Lift clean. Wipe up any spills, clean any dirt.
- **Daily:** Make a visual inspection of all moving parts and check for damage or excessive wear. Replace any damaged or worn parts before using the Lift.

 **DANGER** Do not use the Lift if the cables are damaged or extremely worn. If a vehicle is raised when you notice the damage or extreme wear, very carefully lower the vehicle to the ground. When the Lift is on the ground, take it out of service, disconnect it from power, and make arrangements to fix the damage or wear.

- **Daily:** Make sure all Safety Locks are in good operating condition. Do not use your Lift if the Safety Locks are damaged or excessively worn.
- **Daily:** If this lift is located in an area with snow, ice and/or sleet, remove accumulated snow and ice as soon as possible to prevent a slipping hazard. Clean any road salts from the Lift at the end of the day.
- **Daily:** remove rain water brought in with vehicles as soon as possible to prevent a slipping hazard and corrosion to the lift components.
- **Monthly:** Check all labels on the Lift. Replace them if they are illegible, damaged, or missing.
- **Monthly:** Frequency will depend on usage. Lubrication points on the Lift are described in [Lubricating the Lift](#).
- **Monthly:** Check hydraulic fluid levels. Refill if low.
- **Monthly:** Lubricate the wire rope (cables). Use a wire-rope lubricant such as 90-WT gear oil or ALMASOL® Wire Rope Lubricant.
- **Monthly:** Check cable connections, bolts, and pins for proper mounting and torque.
- **Every two months:** Check all Anchor Bolts to make sure they are properly torqued. If they are loose, tighten them.
- **As required.** Take the Lift out of service and then replace the cables if there are signs of damage or extreme wear.

 **WARNING:** Do not operate your Lift if you find maintenance issues; instead, take the Lift out of service, then contact your dealer, visit bendpak.com/support, email support@bendpak.com, or call **(800) 253-2363**.

Lubricating the Lift

There are several lubrication points on the Lift.

- **Inside of the Lift Posts.** Lubricate the inside of the lift posts in the slide block contact area with a white lithium grease.
- **Lift Cables / Wire Rope** is only fully protected when each wire strand is lubricated both internally and externally. Excessive wear shortens the life of wire rope. Use a wire-rope lubricant that penetrates to the core of the rope and provides long-term lubrication between each individual strand, such as 90-WT gear oil or ALMASOL® Wire Rope Lubricant. To make sure that the inner layers of the rope remain well lubricated, lubrication should be done at least every three months during normal operation.
- **All Sheaves and Sheave Bearings** that contact moving wire rope should be given regular visual checks for surface wear and lubricated to ensure they run freely. This should be done every three months during normal operation.

For all sheave pins and bearings, use standard wheel bearing grease red lithium or equal heavy lubricant, applied by any method including pump/spray dispensing, brush, hand, or swabbing. The following graphic details the lubrication points on the Lift.

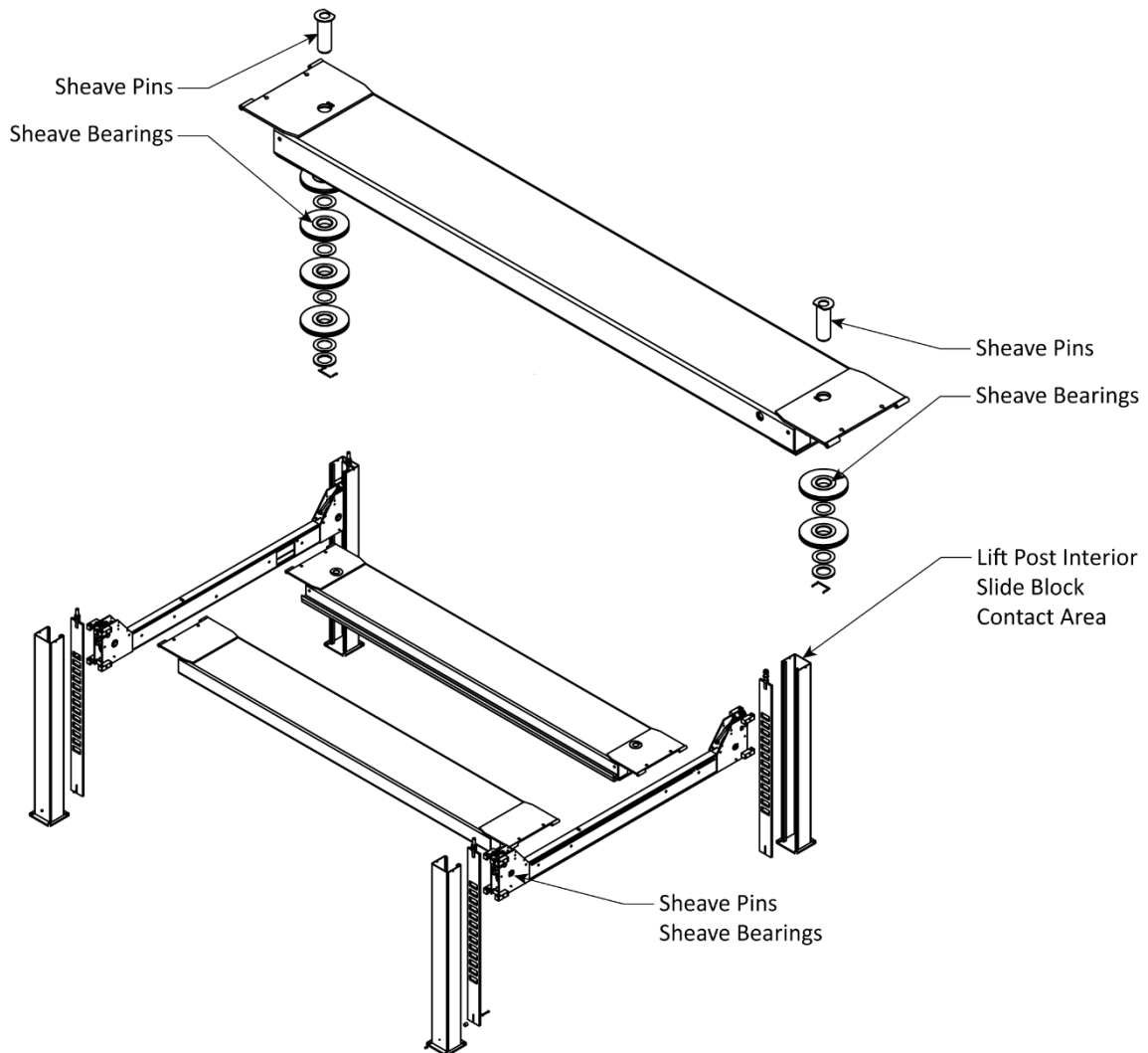

Wire Rope Inspection and Maintenance

The Lift's cables, which are wire rope, should be inspected regularly:

- Wire rope should be replaced when there are visible signs of damage or extreme wear. **Do not use the Lift if it has damaged or worn cables. Take it out of service!**

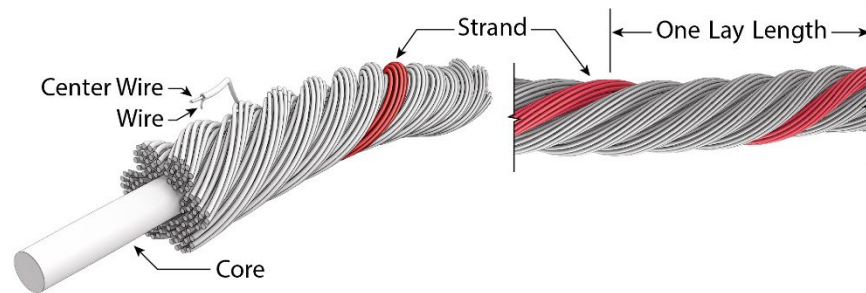

- Wire rope should be maintained in a well-lubricated condition at all times.
Wire rope is only fully protected when each wire strand is lubricated both internally and externally. Excessive wear shortens the life of wire rope. Use a wire-rope lubricant that penetrates to the core of the rope and provides long-term lubrication between each individual strand, such as 90-WT gear oil or ALMASOL® Wire Rope Lubricant. To make sure that the inner layers of the rope remain well lubricated, lubrication should be done at least every three months during normal operation.
- All sheaves and guide rollers that contact moving wire rope should be given regular visual checks for surface wear and lubricated to make sure they run freely. This should be done every three months during normal operation. **See Lubricating the Lift.**
For all sheave axles, use standard wheel bearing grease. For all sheaves and/or guide rollers, use 90-WT gear oil or a similar heavy lubricant, applied by any method including pump/spray dispensing, brush, hand, or swabbing.
- How often should they be inspected?
Wire rope should be visually inspected at least once each day when in use, as suggested by American Petroleum Institute's Recommended Practice 54 guidelines. Any wire rope that meets the criteria for removal must be immediately replaced.
- When should wire rope be replaced due to broken wires?
Wire rope should be removed from service if there are six randomly distributed broken wires within any one lay length (where a single strand makes a full turn around the rope) or three broken wires in one strand within one lay length.
- Are there other reasons to replace the wire rope?
Yes. Corrosion that pits the wires and/or connectors, evidence of kinking, crushing, cutting, bird-caging, a popped core, wear that exceeds 10% of a wire's original diameter, excessive stretching, or heat damage.
- How are broken wires found?
 - a. Relax the rope to a stationary position and move the pick-up points off the sheaves. Clean the surface of the rope with a cloth or a wire brush, if necessary, to see any breaks.
 - b. Flex the rope to expose any broken wires hidden in the valleys between the strands.
 - c. Visually check for any broken wires. One way to check for crown breaks is to run a cloth along the rope to check for snags.
 - d. With an awl, probe between wires and strands and raise any wires that appear loose.

Troubleshooting

This section describes how to troubleshoot your Lift.

Note: If your Lift is not functioning correctly, you must take it out of service until it is fixed.

Important: All repair work **must** be done by qualified personnel.

Runways do not rise or do not lower, once raised.	<p>Make sure there is sufficient hydraulic fluid in the reservoir.</p> <p>Make sure there is no air in the Hydraulic System.</p> <p>Make sure none of the Hydraulic Hoses are pinched or leaking.</p> <p>Make sure the Power Unit is getting power.</p> <p>If the hydraulic fluid is dirty, replace it with clean fluid.</p> <p>Make sure Lift is not overloaded.</p>
Runways do not lower past the nearest Safety Lock even when pressing and holding the pushbutton.	Problem with the air lines; check to make sure all sections of the air line are connected and not leaking.
One corner of the Lift is lower than the other three corners.	The Safety Lock on the lower corner is not engaged. Raise the runways up, then lower them down onto the Safety Locks. Check to make sure all four Safety Locks are engaged.
Runways move erratically or squeak when in use.	Move the runways up and down a few times to flush any residual air from the Hydraulic System. Make sure to pause for at least 2 minutes between cycles.
Runways do not stay up.	<p>Check for leaking hydraulic fluid.</p> <p>Make sure the runways are left on their Safety Locks.</p>
Motor not running.	<p>Check the connection to the power source; make sure it is plugged in and of the appropriate voltage.</p> <p>Check the wiring diagram.</p>
Hydraulic Fluid is dirty.	Replace the dirty fluid with clean, approved ISO hydraulic fluids, or alternative ATF such as Dexron VI, Mercon V, Mercon LV, Shell Tellus S4 / S3 / S2, or comparable.
Runways make odd noises.	Lubricate the bushings on the sheaves on the sides of the Crosstubes using white lithium grease. If the Lift is new, a break-in period may be needed; run the Lift several times each day. If the noise persists, contact BendPak support.

If you continue to have issues with your Lift, take it out of service, then contact your dealer, go to bendpak.com/support, email support@bendpak.com, or call **(800) 253-2363**.

One Corner of the Runway is higher than the other three corners.

⚠ DANGER *Stop lowering immediately! Clear the area of personnel!* This condition indicates that one of the Safety Locks has not disengaged while the operator has allowed the Lift to descend, creating an out-of-balance situation.

1. Place the Lift into a safe condition by raising the Lift until all four corners are equal.
2. Once all four corners are equal, attempt to lower the Lift until it rests on the closest Safety Locks at the same height. This puts the Lift into a safe condition with all 4 Crosstube ends on their Safety Locks.
3. If the Lift cannot be put into a safe condition, contact BendPak support, go to bendpak.com/support, email support@bendpak.com, or call **(800) 253-2363** (follow the prompts).
4. Once the Lift is in a safe condition, inspect it for damage. It is critical to Inspect the inner rails of the Lift Post. If any significant bending or distortion to the formed rails has occurred, then the Lift Post(s) may need to be replaced.

The figure below describes the forces applied, and the damage that can be expected if the operator allows one Safety Lock to remain engaged while the other three are allowed to descend. **Failure to operate or maintain the Lift properly can lead to damage of the columns as shown in the illustration to the right.**

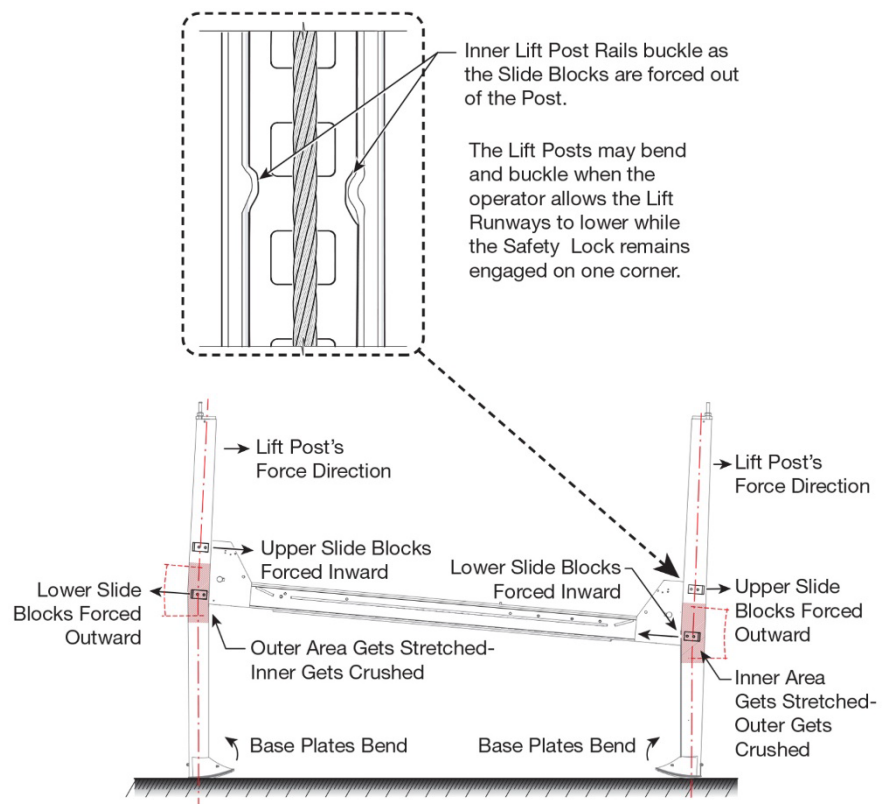

5. If no damage is found, perform the **Lift Cable Adjustment Procedure** found in the **Maintenance** section.

If issues with the Lift continue, take it out of service, then contact the dealer, go to

bendpak.com/support, email techsupport@bendpak.com, or call **(800) 253-2363**. (follow the prompts).

Wiring Diagrams

The diagrams below represent two commonly supplied power units. The power unit delivered with the lift may vary. Always follow the wiring diagram and current information on the power unit.

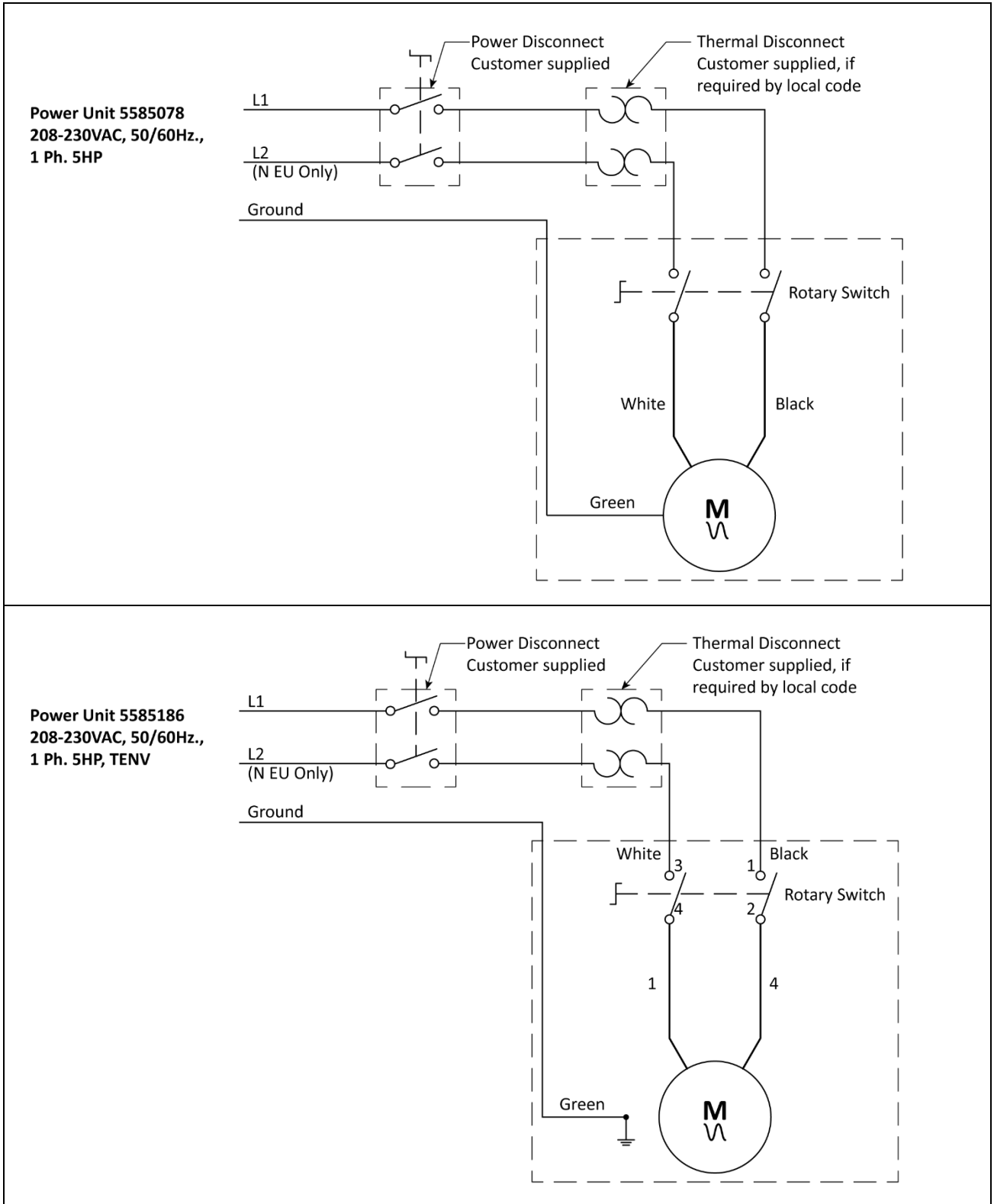

***D**

⚠ DANGER

THE MAXIMUM LIFTING CAPACITY FOR THIS LIFT IS DESCRIBED BELOW

Maximum Lifting Capacity
Max. Lifting Cap. / Front of Lift Center
Max. Lifting Cap. / Rear of Lift Center

Exceeding the weight capacity of this lift can damage lift and/or property and may cause personal harm, injury or death to operators and/or bystanders. All vehicles MUST be positioned on lift with CENTER OF GRAVITY midway between adapters and/or centered on runways. Damage to lift due to overloading or misuse IS NOT covered under warranty.

LA CAPACITÉ DE LEVAGE MAXIMUM POUR CE LEVAGE EST DÉCRIT CI-DESSOUS

Capacité de Levage Maximale
Max. Capacité De Levage. / Avant du centre de relèvement
Max. Capacité De Levage. / Arrière du centre de levage

Le dépassement de la capacité de poids de cet élévateur peut endommager l'ascenseur et / ou les biens et peut causer des dommages corporels, des blessures voire la mort aux opérateurs et / ou aux passants. Tous les véhicules DOIVENT être placés sur l'élévateur avec le CENTRE DE GRAVITÉ à mi-chemin entre les adaptateurs et / ou au centre des pistes. Dommages à soulever dus à la surcharge ou une mauvaise utilisation N'EST PAS couvert par la garantie.

P/N 5905406 - Max Cap. Danger 18k
 P/N 5905407 - Max. Cap. Danger 27K
 P/N 5905409 - Max. Cap. Danger 40K

***DEPENDS ON LIFT MODEL & CAPACITY**

***E**

⚠ ATTENTION ⚠

MAXIMUM LIFTING CAPACITY
 CAPACITÉ DE LEVAGE MAXIMUM

Lbs.
Kg.

P/N 5905675 - NRTL_Lifting_Cap_Label_18k
 P/N 5905680 - NRTL_Lifting_Cap_Label_27k
 P/N 5905690 - NRTL_Lifting_Cap_Label_40K

***DEPENDS ON LIFT MODEL & CAPACITY**

F

BP BendPak

30440 Agoura Road
 Agoura Hills, CA USA
 www.BendPak.com

LIFT TYPE: Surface Mount MANUFACTURER: BendPak. See data plate for product details
 POWER: Electric/Hydraulic INSTALLATION: See manual or contact factory

Safety Instructions: If attachments, accessories, or configuration-modifying components that are located in the load path affect operation of the lift, affect the lift electrical listing, or affect intended vehicle accommodation are used on this lift and, if they are not certified for use on this lift, then the certification of this lift shall become null and void. Contact the participant for information pertaining to certified attachments, accessories, or configuration-modifying components.

BendPak lifts are supplied with concrete fasteners meeting the criteria as prescribed by ASTM E488/E488M-18. Lift buyers are responsible for any special regional, structural, and/or seismic anchoring requirements specified by any other agencies and/or codes such as the Uniform Building Code (UBC) and/or International Building Code (IBC).

The manufacture, use, sale, or import of this product may be subject to one or more United States

PN 5905940

G

NOTICE

If attachments, accessories, or configuration modifying components used on this lift are located in the load path and affect operation of the lift, affect the lift electrical listing, or affect intended vehicle accommodation; and if they are not certified for use on this lift, then the certification of this lift shall become null and void. Contact the participant for information pertaining to certified attachments, accessories, or configuration modifying components.

www.autolift.org ©2011 by ALI, Inc. ALI / WLSIA01

PN 5905377

H

⚠ WARNING

SLIPPERY WHEN WET OR ICY

Use caution when driving onto wet or icy drive-up ramps and platforms. **DO NOT** walk on lift surfaces that are wet or icy.

⚠ AVERTISSEMENT

GLISSANT LORSQU'IL EST MOUILLÉ OU GLACÉ

Soyez prudent lorsque vous conduisez sur des rampes d'accès mouillées ou verglacées et les plateformes. **NE PAS** marcher sur des surfaces de levage humides ou glacées.

PN 5905138

I

CERTIFIED AUTOMOTIVE LIFT

INDEPENDENTLY TESTED
ALI
 CERTIFIED
 AND VALIDATED

ALI CERTIFIED
 To the provisions of
ANSI/ALI ALCTV-2017
 SAFETY REQUIREMENTS FOR
 CONSTRUCTION TESTING
 AND VALIDATION

Automotive Lift Institute, Inc. | Cortland, NY 13045

MET LISTED
 Conforms to
ANSIUL 201
 SAFETY STANDARD FOR
 GARAGE EQUIPMENT

MET LISTED
C **MET** **US**

Certified to
CAN/CSA C22.2 NO.68
 MOTOR OPERATED APPLIANCES
 (HOUSEHOLD & COMMERCIAL)

MET Laboratories, Inc.
 BALTIMORE, MD 21220

Certification Label Serial Number
 AL00617000M

PN 5905654

****FOR ALI APPROVED LIFTS ONLY**

J

NAMEPLATE

PN 5906156

K



PN 5906163

L

CALIFORNIA PROPOSITION 65

⚠ WARNING ⚠

WARNING! This product can expose you to chemicals including styrene and vinyl chloride which are on the list of over 900 chemicals identified by the State of California to cause cancer, birth defects or reproductive harm. ALWAYS use this product in accordance with the manufacturer's instructions. For more information, go to www.p65warnings.ca.gov.

PN 5905775

PN 5905775

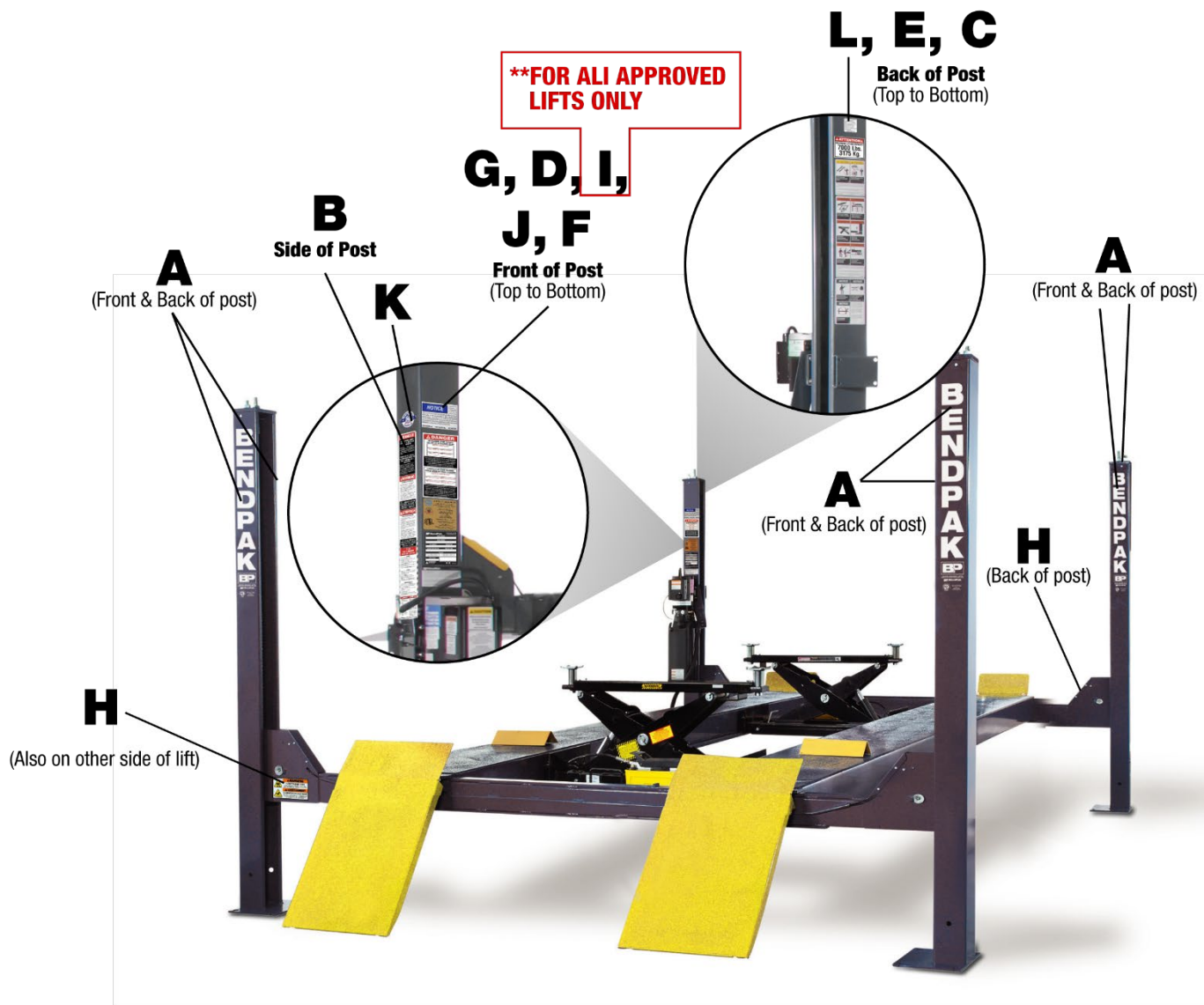

Views of Powerside Post

BACK OF POST

SIDE OF POST

FRONT OF POST

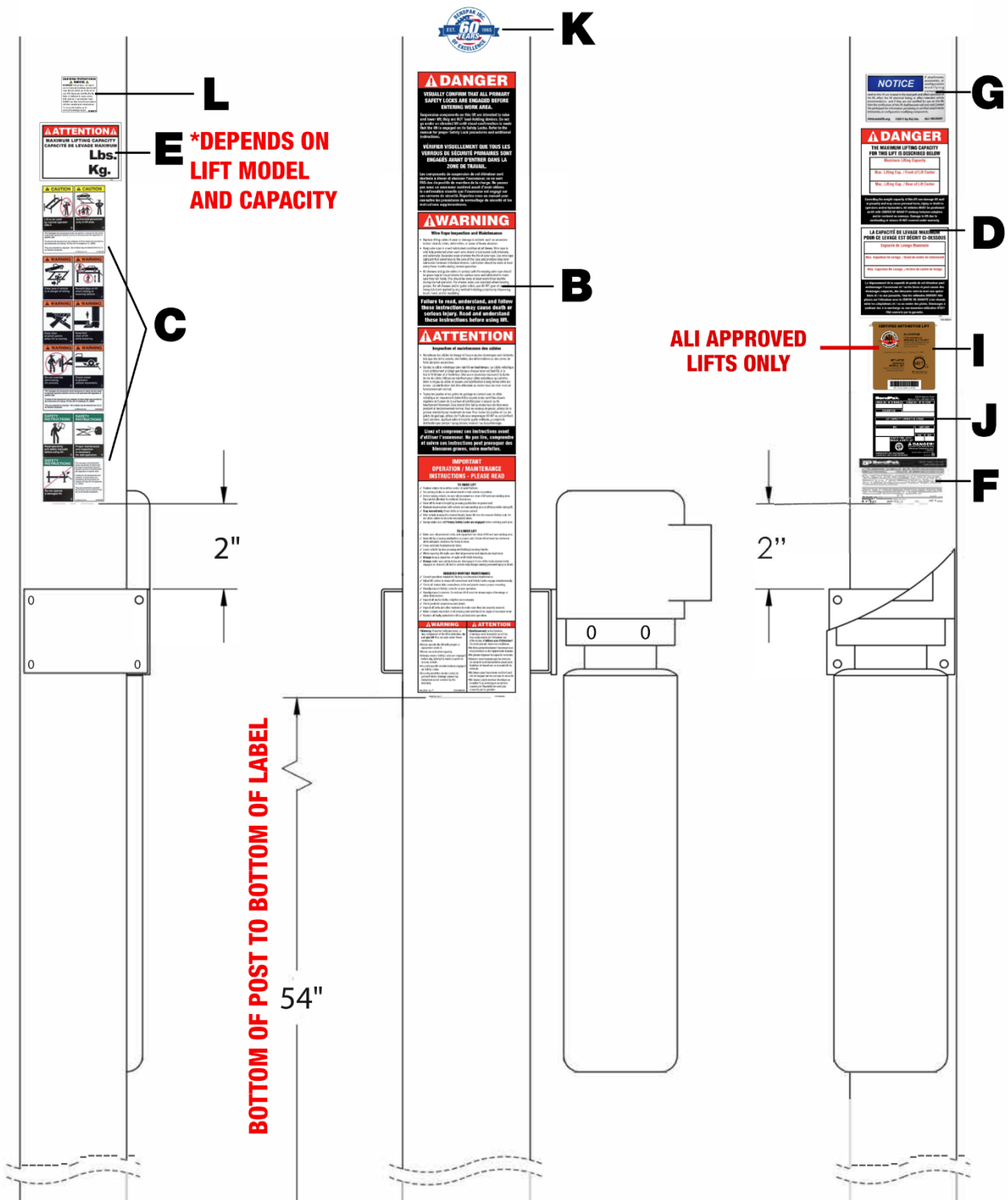

Parts Drawings

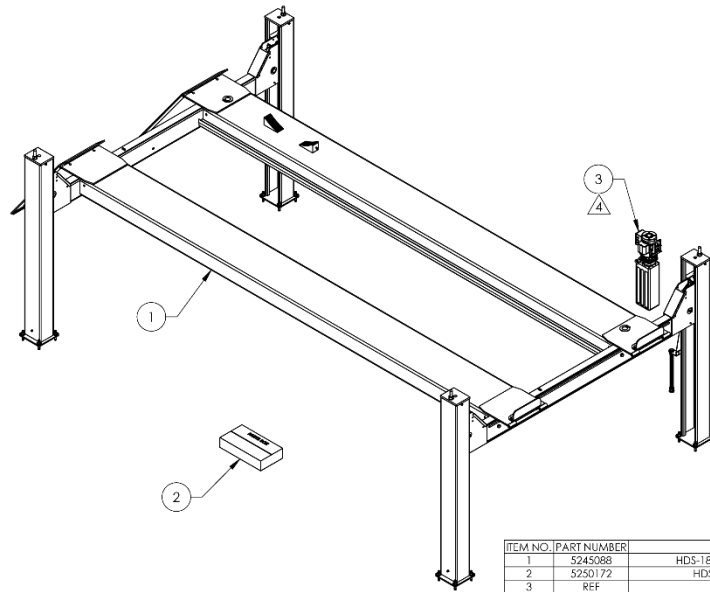

- NOTE: UNLESS OTHERWISE SPECIFIED**
1. REFER TO MODEL FOR ADDITIONAL INFORMATION
 2. SEE SHIPPING INSTRUCTIONS FOR FINAL PACKAGING
 3. SEE COLORS & GRAPHICS FOR LABEL PLACEMENT
 4. POWER UNIT REFERENCE ON PURCHASE ORDER

ITEM NO.	PART NUMBER	DESCRIPTION	QTY.
1	5245088	HDS-18E LIFT SUPERSTRUCTURE	1
2	5250172	HDS-18E/27 PARTS BOX	1
3	REF	POWER UNIT	1

DRAWN		NAME	DATE	 1645 EWOAKWOOD DR. SANTA PAULA, CA 95066
CHECKED		BY	12/12/2019	
DIMENSIONS ARE IN INCH THIRD ANGLE PROJECTION				TITLE: HDS-18E PRODUCTION LIFT VER D (CE CERT)
PROPRIETARY AND CONFIDENTIAL THE INFORMATION CONTAINED HEREIN IS THE SOLE PROPERTY OF BENDPAK INC. ANY DISCLOSURE OR REPRODUCTION OF THIS INFORMATION WITHOUT THE WRITTEN PERMISSION OF BENDPAK INC. IS STRICTLY PROHIBITED.				SIZE DWG. NO. A 5260604
SCALE: 1:40				SHEET 1 OF 3

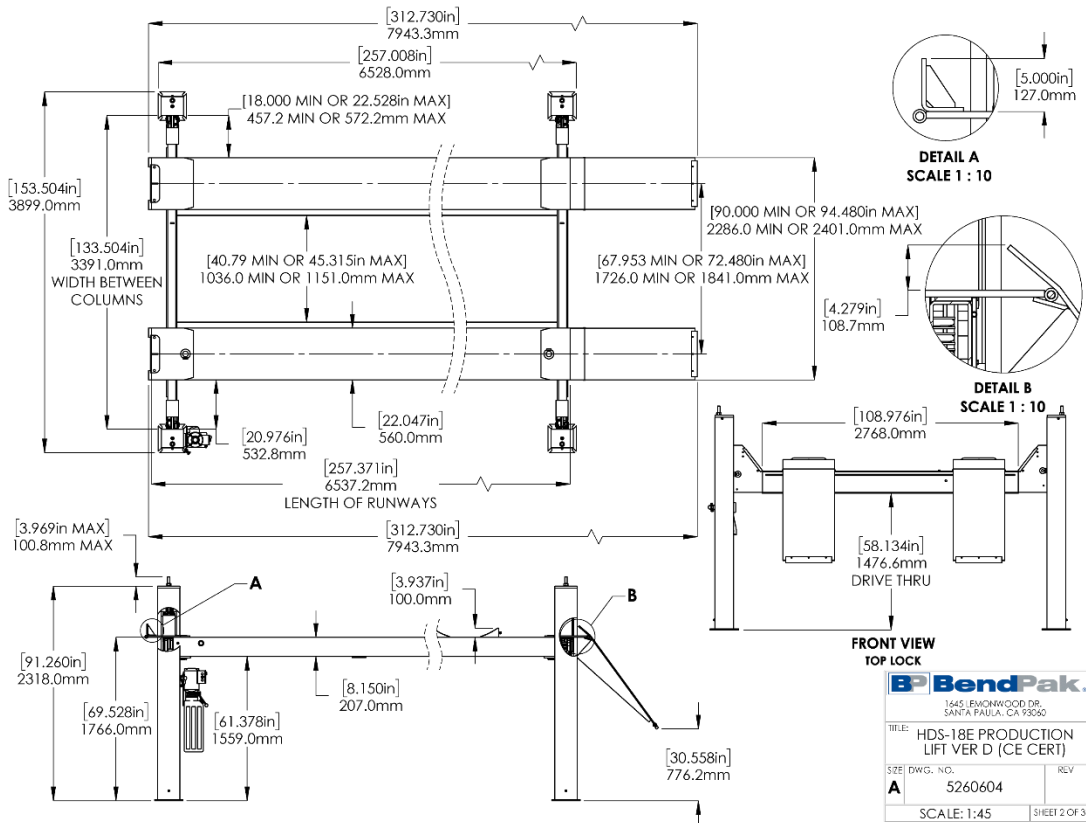

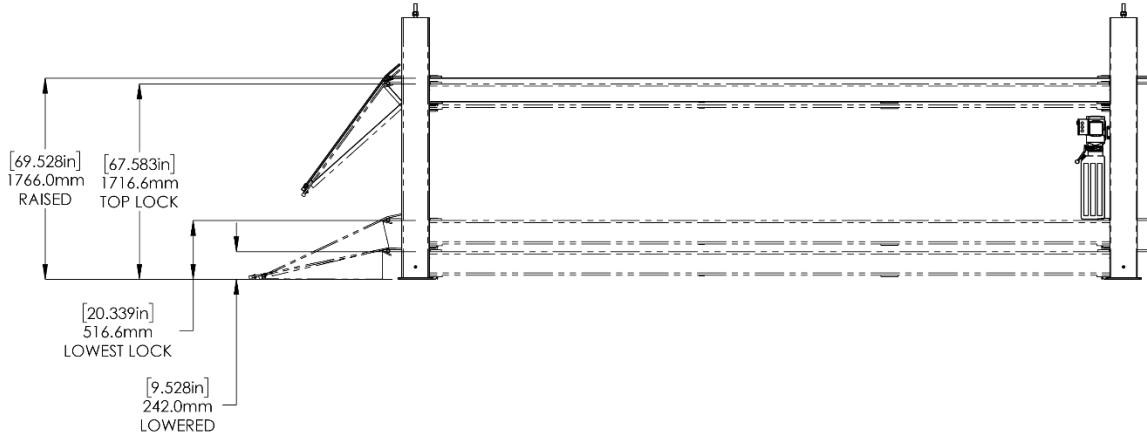

1. DIMENSIONS ARE WITH THE LOCK LADDER ADJUSTED ALL THE WAY UP
2. SAFETY LOCK POSITIONS: I3
3. SPACED EVERY: 100.0mm / 3.937"

BendPak
 1645 LEMONWOOD DR.
 SANTA PAULA, CA 93060

TITLE: HDS-18E PRODUCTION
 LIFT VER D (CE CERT)

SIZE DWG. NO. **A** 5260604 REV

SCALE: 1:40 SHEET 3 OF 3

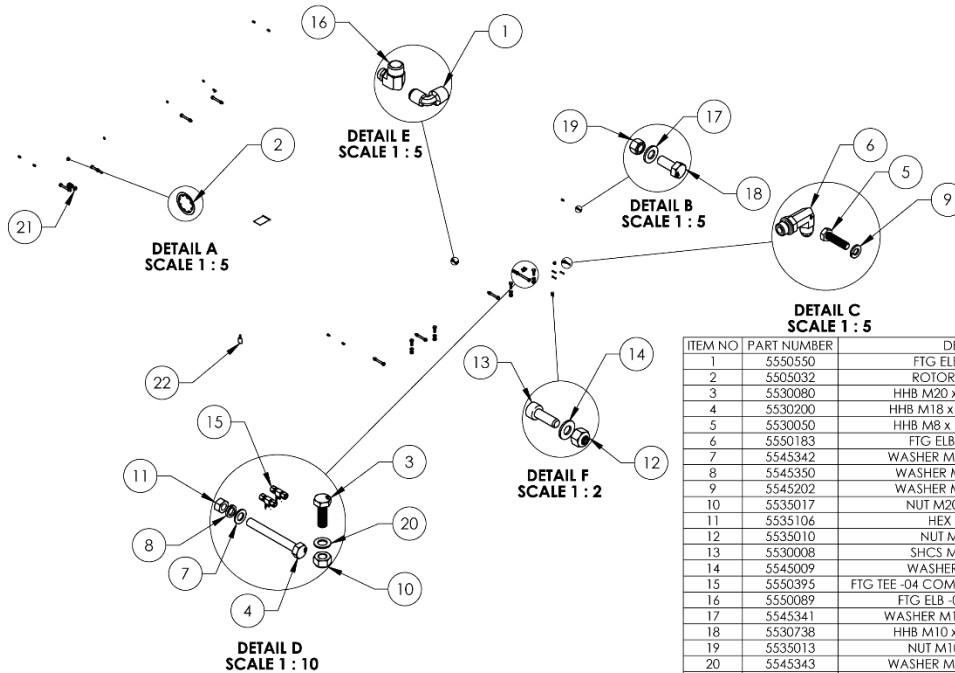

ITEM NO	PART NUMBER	DESCRIPTION	QTY
1	5550550	FTG ELB -06 JIC -06 NPT	1
2	5505032	ROTOR CLIP Ø18mm SS	4
3	5530080	HHB M20 x 2.5 x 60 FT. CL 10.9	4
4	5530200	HHB M18 x 1.25 x 30 FT. CL 10.9	8
5	5530050	HHB M8 x 1.25 x 30 FT. CL 10.9	4
6	5550183	FTG ELB -06 JIC -06L ORB	1
7	5545342	WASHER M18 x 34 FLAT, CL 10.9	8
8	5545350	WASHER M18 x 28 SL, CL 10.9	8
9	5545202	WASHER M8 x Ø15 SL, CL10.9	4
10	5535017	NUT M20 x 2.5 NL, CL 10.9	4
11	5535106	HEX NUT M18 x 2.5	8
12	5535010	NUT M4 x 0.7, NL CL8	2
13	5530008	SHCS M4 x 0.7 x 12 BOC	2
14	5545009	WASHER, M4 x 9mm FLAT	2
15	5550395	FTG TEE -04 COMP x -04 COMP x -04 COMP	3
16	5550089	FTG ELB -04 COMP x -06 NPT	2
17	5545341	WASHER M10 x Ø20 FLAT, CL10.9	8
18	5530738	HHB M10 x 1.5 x 25 FT. CL 10.9	8
19	5535013	NUT M10 x 1.5 NL, CL10.9	8
20	5545343	WASHER M20 x 37 FLAT, CL 10.9	4
21	5545535	C WASHER SHIM FOR LIFTS	20
22	5580012	LIQUID PTFE THREAD SEALANT 50ml	1

WHERE USED
HDS-18E
HDS-27 SERIES
HDS-40 SERIES

NOTE: UNLESS OTHERWISE SPECIFIED
 1. SEE SHIPPING INSTRUCTIONS FOR FINAL PACKAGING

NEXT ASSEMBLY
5250079
5250082
5250172
5250175
5250364
5250388

DO NOT SCALE DRAWING

NAME AC DATE 05/06/2009

BendPak
 1645 LEMONWOOD DR.
 SANTA PAULA, CA 93060

TITLE: HDS-18E/27/40
 PARTS BAG

SIZE DWG. NO. **A** 5174600 REV

SCALE: 1:50 SHEET 1 OF 1

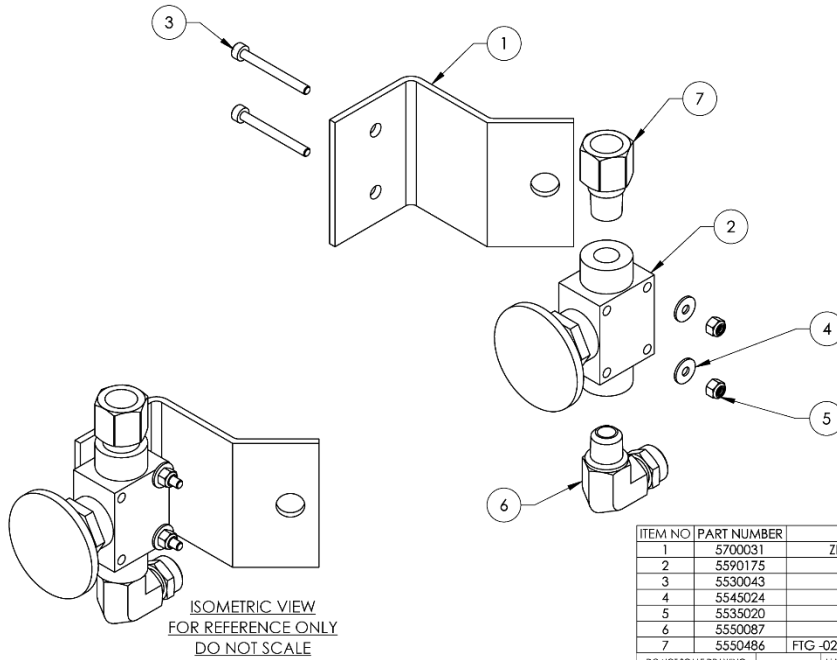

ITEM NO	PART NUMBER	DESCRIPTION	QTY
1	5700031	ZERO ANGLE MOUNTING BRACKET	1
2	5590175	PUSH BUTTON AIR VALVE	1
3	5530043	SHCS M3 x 0.5 x 30	2
4	5545024	WASHER, M3 x 9mm FLAT	2
5	5535020	NUT M3 x 0.5, NL CL8	2
6	5550087	FTG ELB -04 COMP x -02 NPT	1
7	5550486	FTG -02 NPTIF x -04 F NPTIF, STRAIGHT EXPANDER	1

DO NOT SCALE DRAWING

DRAWN	AC	03/14/2008	BendPak 1445 LEMONWOOD DR. SANTA PAULA, CA 93060
CHECKED	CA	09/02/2015	

THIRD ANGLE PROJECTION

TITLE: PUSH BUTTON AIR ASSEMBLY

SIZE DWG. NO. REV

A 5215096

SCALE: 2:3 SHEET 1 OF 1

PROPRIETARY AND CONFIDENTIAL
THE INFORMATION CONTAINED IN THIS DRAWING IS THE SOLE PROPERTY OF BENDPAK INC. ANY REPRODUCTION IN PART OR AS A WHOLE WITHOUT THE WRITTEN PERMISSION OF BENDPAK INC. IS PROHIBITED.

NEXT ASSEMBLY

HD SERIES
HDS SERIES
HDSO SERIES
PL-12000 SERIES
FL14 SERIES

- NOTE: UNLESS OTHERWISE SPECIFIED...**
- SEE SHIPPING INSTRUCTIONS FOR FINAL PACKAGING
 - ASSEMBLE ITEMS AS SHOWN

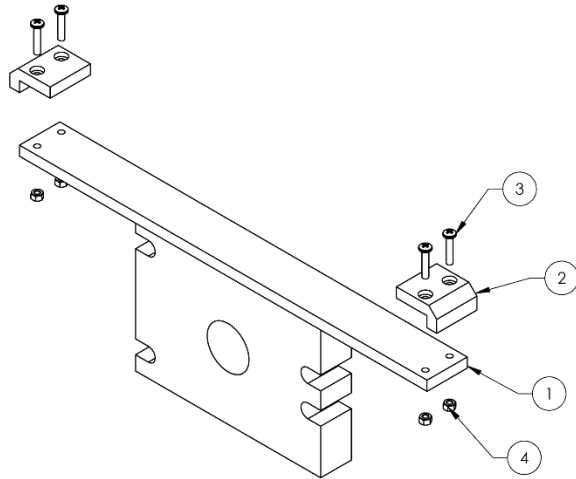

ITEM NO	PART NUMBER	DESCRIPTION	QTY
1	5620202	HDS-18/27 CYLINDER FLANGE ARM WELDMENT	1
2	5716153	HDS-18/27/40 SERIES ALIGNMENT BLOCK	2
3	5530095	BHPS M6 x 1 x 30mmL	4
4	5535357	NUT M6 x 1.0 NL	4

DO NOT SCALE DRAWING

DRAWN	GJE	10/21/2008	BendPak 1445 LEMONWOOD DR. SANTA PAULA, CA 93060
CHECKED	CA	10/30/2018	

THIRD ANGLE PROJECTION

TITLE: HDS-18/27 SERIES CYLINDER FLANGE ARM ASSEMBLY

SIZE DWG. NO. REV

A 5215159

SCALE: 1:4 SHEET 1 OF 1

PROPRIETARY AND CONFIDENTIAL
THE INFORMATION CONTAINED IN THIS DRAWING IS THE SOLE PROPERTY OF BENDPAK INC. ANY REPRODUCTION IN PART OR AS A WHOLE WITHOUT THE WRITTEN PERMISSION OF BENDPAK INC. IS PROHIBITED.

NEXT ASSEMBLY

5215157
5215164
5215657
5215689

- NOTE: UNLESS OTHERWISE SPECIFIED...**
- SEE SHIPPING INSTRUCTIONS FOR FINAL PACKAGING
 - ASSEMBLE ITEMS AS SHOWN

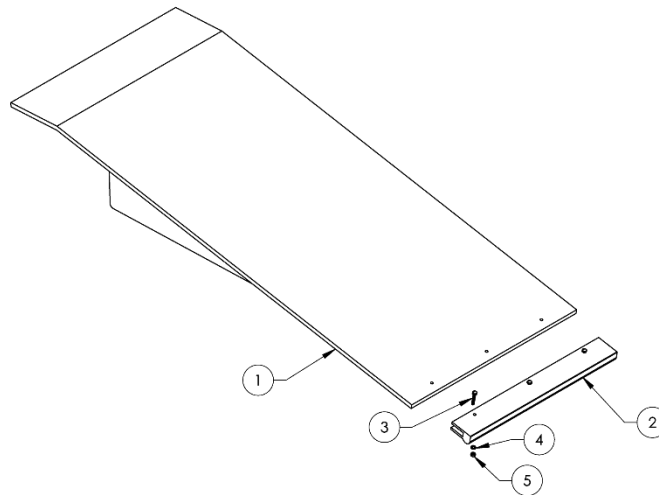
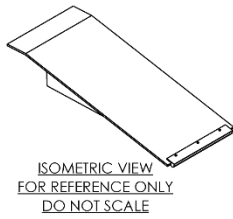

WHERE USED
HDS-18 SERIES
HDS-27 SERIES

NOTE: UNLESS OTHERWISE SPECIFIED

1. REFER TO MODEL FOR ADDITIONAL INFORMATION
2. SEE SHIPPING INSTRUCTIONS FOR FINAL PACKAGING
3. ASSEMBLE ITEMS AS SHOWN

NEXT ASSEMBLY
5245086
5245087
5245088
5245089
5245090

ITEM NO	PART NUMBER	DESCRIPTION	QTY
1	5600196	HDS-18/27 EXTENDED DRIVE UP RAMP WELDMENT	1
2	5716088	HDS-18/27 APPROACH RAMP EDGE GUARD	1
3	5530027	HHB M6 x 1.0 x 35 FT, CL 10.9	3
4	5545005	WASHER M6 x 12 FLAT, CL 10.9	3
5	5535357	NUT M6 x 1.0 NL, CL10.9	3

DO NOT SCALE DRAWING	NAME	DATE	 1445 LEMONWOOD DR. SANTA PAULA, CA 93060
	AC	05/04/2009	
	CHECKED	OR	12/13/2022
DIMENSIONS ARE IN MM	THIRD ANGLE PROJECTION		TITLE
 <small>PROPRIETARY AND CONFIDENTIAL THE INFORMATION CONTAINED IN THIS DRAWING IS THE SOLE PROPERTY OF BENDPAK INC. IT IS TO BE USED FOR THE MANUFACTURE OF BENDPAK EQUIPMENT ONLY. REPRODUCTION IN ANY MANNER WITHOUT THE WRITTEN PERMISSION OF BENDPAK INC. IS PROHIBITED.</small>			HDS-18/27 EXTENDED DRIVE UP RAMP ASSEMBLY
	SIZE DWG. NO.	REV	A 5215161

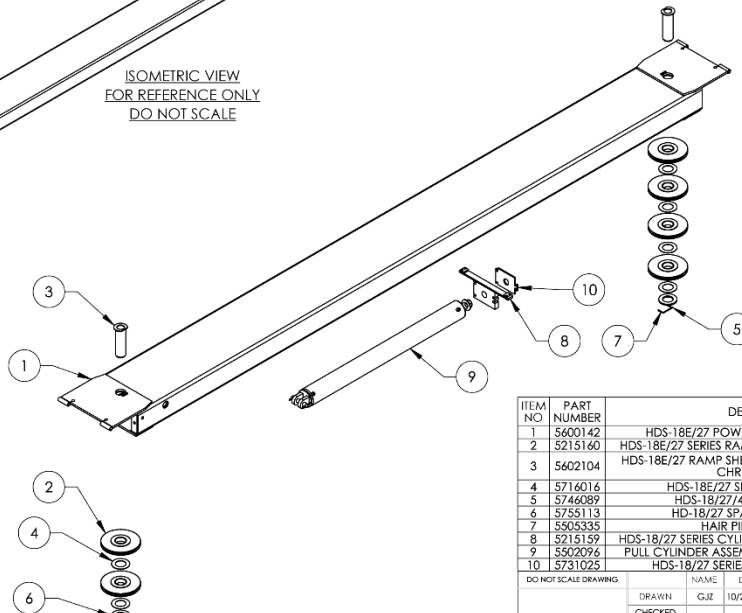
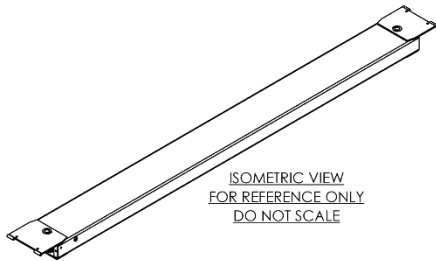

WHERE USED
HDS-18E
HDS-27

NOTE: UNLESS OTHERWISE SPECIFIED

1. REFER TO MODEL FOR ADDITIONAL INFORMATION
2. SEE SHIPPING INSTRUCTIONS FOR FINAL PACKAGING
3. ASSEMBLE ITEMS AS SHOWN
4. VERIFY CYLINDER PORTS ARE CAPPED OFF WITH 3/8" NPT STEEL PLUG

NEXT ASSEMBLY
5245088
5245090

ITEM NO	PART NUMBER	DESCRIPTION	QTY
1	5600142	HDS-18E/27 POWER SIDE RAMP WELDMENT	1
2	5215160	HDS-18E/27 SERIES RAMP SHEAVE ROLLER ASSEMBLY	6
3	5602104	HDS-18E/27 RAMP SHEAVE PIN WELDMENT, Ø80mm CHROME PLATED	2
4	5716016	HDS-18E/27 SERIES SHEAVE SPACER	6
5	5746089	HDS-18/27/40 SHEAVE SHAFT PIN	2
6	5755113	HD-18/27 SPACER, RAMP SHEAVE	2
7	5505335	HAIR PIN 3/32" x 1.5/8"	4
8	5215159	HDS-18/27 SERIES CYLINDER FLANGE ARM ASSEMBLY	1
9	5502096	PULL CYLINDER ASSEMBLY Ø25.0 x 60 - HYDRA LOCK	1
10	5731025	HDS-18/27 SERIES CABLE RETAINER PLATE	1

DO NOT SCALE DRAWING	NAME	DATE	 1445 LEMONWOOD DR. SANTA PAULA, CA 93060
	GJZ	10/23/2008	
	CHECKED		
DIMENSIONS ARE IN MM	THIRD ANGLE PROJECTION		TITLE
 <small>PROPRIETARY AND CONFIDENTIAL THE INFORMATION CONTAINED IN THIS DRAWING IS THE SOLE PROPERTY OF BENDPAK INC. IT IS TO BE USED FOR THE MANUFACTURE OF BENDPAK EQUIPMENT ONLY. REPRODUCTION IN ANY MANNER WITHOUT THE WRITTEN PERMISSION OF BENDPAK INC. IS PROHIBITED.</small>			HDS-18E/27 POWER SIDE RAMP ASSEMBLY
	SIZE DWG. NO.	REV	A 5215164

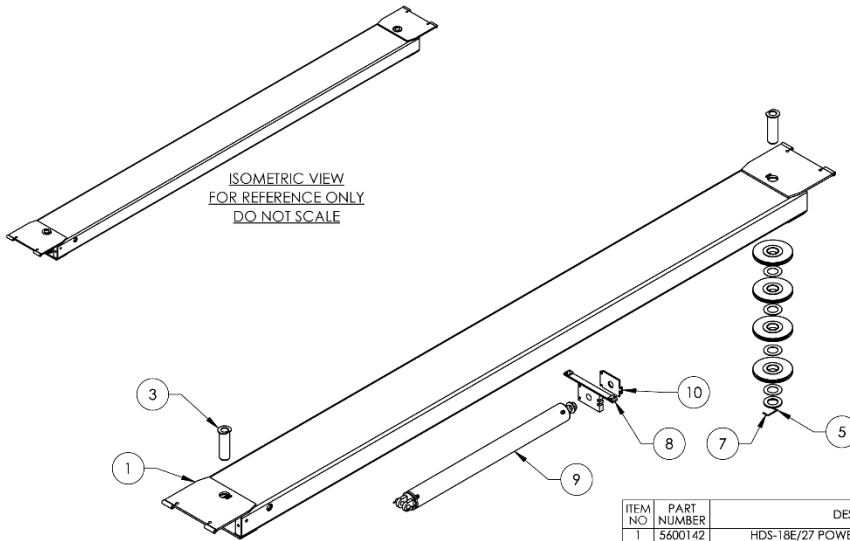

ISOMETRIC VIEW
FOR REFERENCE ONLY
DO NOT SCALE

WHERE USED
HDS-18E
HDS-27

NOTE: UNLESS OTHERWISE SPECIFIED

1. REFER TO MODEL FOR ADDITIONAL INFORMATION
2. SEE SHIPPING INSTRUCTIONS FOR FINAL PACKAGING
3. ASSEMBLE ITEMS AS SHOWN
4. VERIFY CYLINDER PORTS ARE CAPPED OFF WITH 3/8" NPT STEEL PLUG

ITEM NO	PART NUMBER	DESCRIPTION	QTY
1	5600142	HDS-18E/27 POWER SIDE RAMP WELDMENT	1
2	5215160	HDS-18E/27 SERIES RAMP SHEAVE ROLLER ASSEMBLY	6
3	5602104	HDS-18E/27 RAMP SHEAVE PIN WELDMENT, Ø80mm CHROME PLATED	2
4	5716016	HDS-18E/27 SERIES SHEAVE SPACER	6
5	5746089	HDS-18/27/40 SHEAVE SHAFT PIN	2
6	5755113	HD-18/27 SPACER, RAMP SHEAVE	2
7	5505335	HAIR PIN 3/32" x 1 5/8"	4
8	5215159	HDS-18/27 SERIES CYLINDER FLANGE ARM ASSEMBLY	1
9	5502096	PULL CYLINDER ASSEMBLY Ø5.0 x 60 - HYDRALOCK	1
10	5731025	HDS-18/27 SERIES CABLE RETAINER PLATE	1

DO NOT SCALE DRAWING

NAME: GJZ DATE: 10/23/2008

DRAWN: GJZ CHECKED: [Signature]

THIRD ANGLE PROJECTION

TITLE: HDS-18E/27 POWER SIDE RAMP ASSEMBLY

SIZE DWG. NO. A 5215164

SCALE: 1:32 SHEET 1 OF 2

PROPRIETARY AND CONFIDENTIAL
THE INFORMATION CONTAINED IN THIS DRAWING IS THE SOLE PROPERTY OF BENDPAK INC. NO PART OF THIS DRAWING IS TO BE REPRODUCED OR TRANSMITTED IN ANY FORM OR BY ANY MEANS WITHOUT THE WRITTEN PERMISSION OF BENDPAK INC.

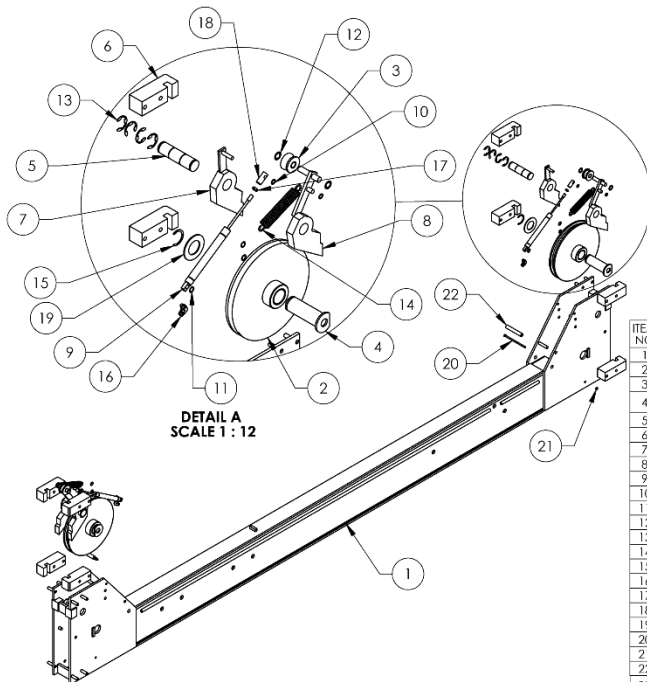

DETAIL A
SCALE 1:12

WHERE USED
HDS-18 SERIES
HDS-27 SERIES

NOTE: UNLESS OTHERWISE SPECIFIED

1. REFER TO MODEL FOR ADDITIONAL INFORMATION
2. SEE SHIPPING INSTRUCTIONS FOR FINAL PACKAGING
3. ASSEMBLE ITEMS AS SHOWN

ITEM NO	PART NUMBER	DESCRIPTION	QTY
1	5601832	HDS-18/27 CROSSTUBE WELDMENT, SMALL WINDOW	1
2	5215166	HDS-18/27 CROSSTUBE SHEAVE ASSEMBLY	2
3	5215169	HDS-18/27 SAFETY ROLLER ASSEMBLY	2
4	5602100	4 POST HEAVY DUTY CROSSTUBE SHEAVE PIN WELDMENT, Ø44mm	2
5	5505125	HDS-18/27/40 SAFETY PIN	2
6	5716152	HDS-18/27 POLYETHYLENE SLIDE BLOCK	8
7	5210359	HDS-18/27/40 SAFETY WELDMENT #1	2
8	5210358	HDS-18/27/40 SAFETY WELDMENT #2	2
9	5502335	AIR CYLINDER, Ø.75 x 4.0" STROKE	2
10	5505030	PUSH-ON CLIP Ø10mm SS	4
11	5505031	ROTOR CLIP Ø12mm SS	6
12	5505033	PUSH-ON CLIP Ø14mm SS	4
13	5540002	E RING Ø1.375" OD TRIARC X3133-137	8
14	5540060	SPRINGS Ø29 x 178mm, SLACK SAFETY	2
15	5540112	SNAP RING; TRIARC 5103-175	2
16	5550087	FTG ELB -Ø4 COMP x-Ø2 NPT	2
17	5535101	3/8-16 HEX NUT JAM	2
18	5550376	HDS-18/27/40 ADAPTER, 1" AIR CYLINDER	2
19	5545108	WASHER M45 x 80 FLAT	2
20	5530317	HHB M6 x 1 x 136	2
21	5535357	NUT M6 x 1.0 NL, CL10.9	2
22	5755158	CROSSTUBE END PLATE SPACER, 102mm	2

DO NOT SCALE DRAWING

NAME: TM DATE: 05/02/2022

DRAWN: TM CHECKED: [Signature]

THIRD ANGLE PROJECTION

TITLE: HDS-18/27 CROSSTUBE ASSEMBLY, SMALL WINDOW

SIZE DWG. NO. A 5216167

SCALE: 1:20 SHEET 1 OF 1

PROPRIETARY AND CONFIDENTIAL
THE INFORMATION CONTAINED IN THIS DRAWING IS THE SOLE PROPERTY OF BENDPAK INC. NO PART OF THIS DRAWING IS TO BE REPRODUCED OR TRANSMITTED IN ANY FORM OR BY ANY MEANS WITHOUT THE WRITTEN PERMISSION OF BENDPAK INC.

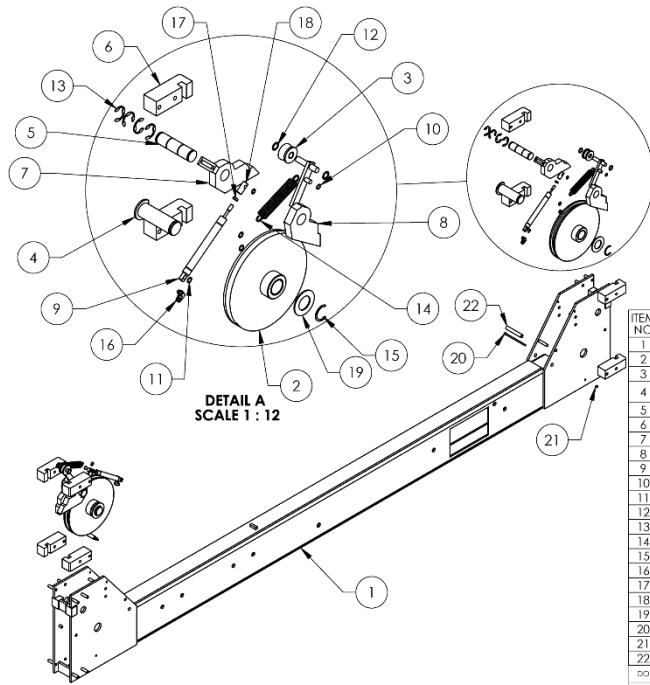

DETAIL A
SCALE 1 : 12

WHERE USED
HDS-18 SERIES
HDS-27 SERIES

NOTE: UNLESS OTHERWISE SPECIFIED

1. REFER TO MODEL FOR ADDITIONAL INFORMATION
2. SEE SHIPPING INSTRUCTIONS FOR FINAL PACKAGING
3. ASSEMBLE ITEMS AS SHOWN

ITEM NO	PART NUMBER	DESCRIPTION	QTY
1	5601831	HDS-18/27 CROSSTUBE WELDMENT, LARGE WINDOW	1
2	5215166	HDS-18/27 CROSSTUBE SHEAVE ASSEMBLY	2
3	5215169	HDS-18/27 SAFETY ROLLER ASSEMBLY	2
4	5602100	4 POST HEAVY DUTY CROSSTUBE SHEAVE PIN WELDMENT, Ø44mm	2
5	5505125	HDS-18/27/40 SAFETY PIN	2
6	5716152	HDS-18/27 POLYETHYLENE SLIDE BLOCK	8
7	5210359	HDS-18/27/40 SAFETY WELDMENT #1	2
8	5210358	HDS-18/27/40 SAFETY WELDMENT #2	2
9	5502335	AIR CYLINDER, Ø.75 x 4.0" STROKE	2
10	5505030	PUSH-ON CLIP Ø10mm SS	4
11	5505031	ROTOR CLIP Ø12mm SS	6
12	5505033	PUSH-ON CLIP Ø16mm SS	4
13	5540002	E RING Ø1.375" OD TRUARC X5133-137	8
14	5540060	SPRING Ø29 x 178mm, SLACK SAFETY	2
15	5540112	SNAP RING, TRUARC 5103-175	2
16	5550087	FTG-ELB-Ø4 COMP x-Ø2 INPT	2
17	5535101	3/8-16 HEX NUT JAM	2
18	5550376	HDS-18/27/40 ADAPTER, 1" AIR CYLINDER	2
19	5545108	WASHER M45 x 80 FLAT	2
20	5530317	HHB M6 x 1 x 136	2
21	5535357	NUT M6 x 1.0 NL, CL10.9	2
22	5755158	CROSSTUBE END PLATE SPACER, 102mm	2

DO NOT SCALE DRAWING

DRAWN	TM	05/02/2022
CHECKED		

1645 LEMONWOOD DR.
SANTA PAULA, CA 93060

BendPak

TITLE: HDS-18/27 CROSSTUBE ASSEMBLY, LARGE WINDOW

SIZE: DWG. NO. 5216168 REV

SCALE: 1:20 SHEET 1 OF 1

NEXT ASSEMBLY

5245086
5245087
5245088
5245089
5245090



THIRD ANGLE PROJECTION

PROPERTY AND CONFIDENTIAL INFORMATION OF BENDPAK INC. DRAWING IS THE PROPERTY OF BENDPAK INC. IT IS TO BE USED ONLY FOR THE PURPOSES SPECIFIED THEREIN. ALL RIGHTS RESERVED BY BENDPAK INC.

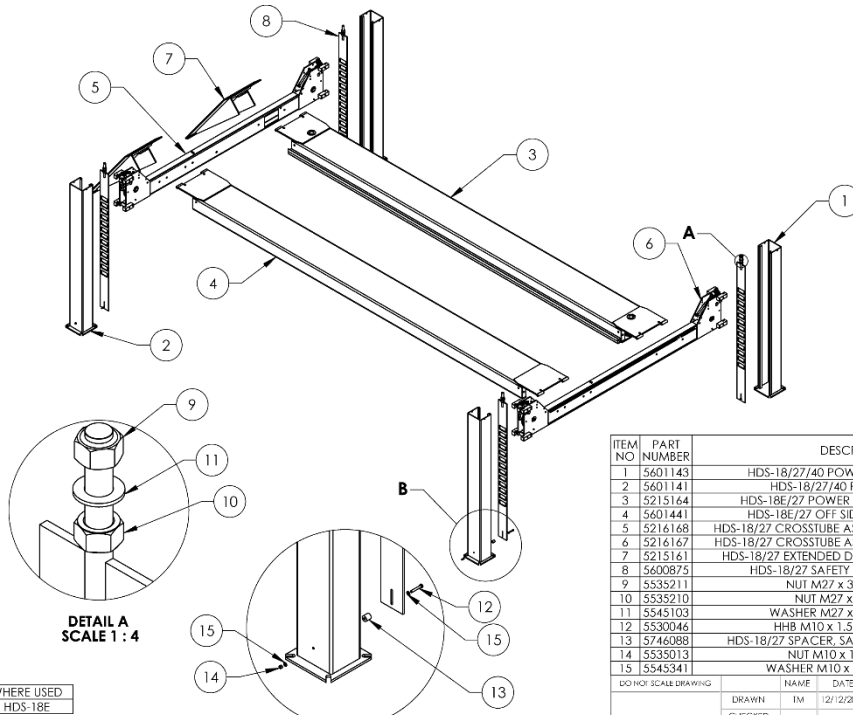

DETAIL A
SCALE 1 : 4

DETAIL B
SCALE 1 : 20

WHERE USED
HDS-18E

NOTE: UNLESS OTHERWISE SPECIFIED

1. REFER TO MODEL FOR ADDITIONAL INFORMATION
2. FASTEN NUTS AND WASHERS TO SAFETY LADDERS IN ORDER SHOWN FOR SHIPMENT
3. SEE SHIPPING INSTRUCTIONS FOR FINAL PACKAGING

ITEM NO	PART NUMBER	DESCRIPTION	QTY
1	5601143	HDS-18/27/40 POWER POST WELDMENT	1
2	5601141	HDS-18/27/40 POST WELDMENT	3
3	5215164	HDS-18E/27 POWER SIDE RAMP ASSEMBLY	1
4	5601441	HDS-18E/27 OFF SIDE RAMP WELDMENT	1
5	5216168	HDS-18/27 CROSSTUBE ASSEMBLY, LARGE WINDOW	1
6	5216167	HDS-18/27 CROSSTUBE ASSEMBLY, SMALL WINDOW	1
7	5215161	HDS-18/27 EXTENDED DRIVE UP RAMP ASSEMBLY	2
8	5600875	HDS-18/27 SAFETY LADDER WELDMENT	4
9	5535211	NUT M27 x 3.0 NL, CL 10.9	4
10	5535210	NUT M27 x 3.0, CL 10.9	4
11	5545103	WASHER M27 x 50 FLAT, CL 10.9	4
12	5530046	HHB M10 x 1.5 x 65 PT, CL 10.9	4
13	5746088	HDS-18/27 SPACER, SAFETY LADDER, 31mm LG	4
14	5535013	NUT M10 x 1.5 NL, CL10.9	4
15	5545341	WASHER M10 x Ø20 FLAT, CL10.9	8

DO NOT SCALE DRAWING

DRAWN	TM	12/12/2019
CHECKED		

1645 LEMONWOOD DR.
SANTA PAULA, CA 93060

BendPak

TITLE: HDS-18E LIFT SUPERSTRUCTURE

SIZE: DWG. NO. 5245088 REV

SCALE: 1:55 SHEET 1 OF 1

NEXT ASSEMBLY

5260604



THIRD ANGLE PROJECTION

PROPERTY AND CONFIDENTIAL INFORMATION OF BENDPAK INC. DRAWING IS THE PROPERTY OF BENDPAK INC. IT IS TO BE USED ONLY FOR THE PURPOSES SPECIFIED THEREIN. ALL RIGHTS RESERVED BY BENDPAK INC.

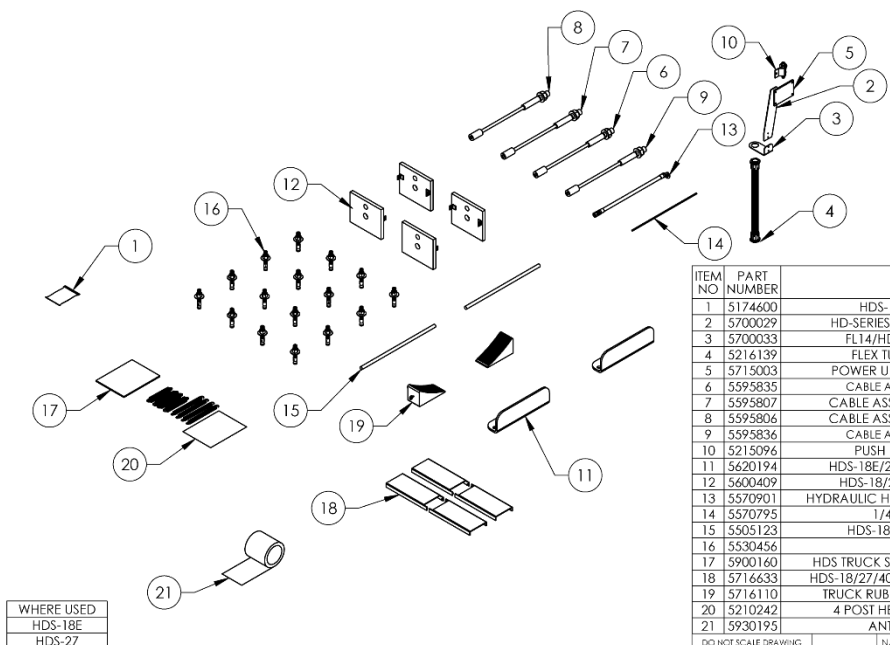

WHERE USED
HDS-18E
HDS-27

- NOTE: UNLESS OTHERWISE SPECIFIED**
- REFER TO MODEL FOR ADDITIONAL INFORMATION
 - SEE SHIPPING INSTRUCTIONS FOR FINAL PACKAGING
 - HOSES AND CABLES IN REPRESENTATIONAL FORM
 - (*) LENGTH FOR REFERENCE ONLY

ITEM NO.	PART NUMBER	DESCRIPTION	QTY.
1	5174600	HDS-18E/27/40 PARTS BAG	1
2	5700029	HD-SERIES FLEX TUBE BRACKET PLATE	1
3	5700033	FL14/HD/HDS FLEX TUBE ANGLE	1
4	5216139	FLEX TUBE KIT, UP TO 2000mm	1
5	5715003	POWER UNIT VIBRATION DAMPENER	1
6	5595835	CABLE ASSEMBLY Ø16 x 4127mm ST	1
7	5595807	CABLE ASSEMBLY Ø16 x 12215mm ST	1
8	5595806	CABLE ASSEMBLY Ø16 x 10483mm ST	1
9	5595836	CABLE ASSEMBLY Ø16 x 5855mm ST	1
10	5215096	PUSH BUTTON AIR ASSEMBLY	1
11	5620194	HDS-18E/27/40 TIRE STOP WELDMENT	2
12	5600409	HDS-18/27 TOP PLATE WELDMENT	4
13	5570901	HYDRAULIC HOSE ASSEMBLY Ø10 x 5385mm	1
14	5570795	1/4" POLY-FLO TUBING	24000mm*
15	5505123	HDS-18/27 DRIVE UP RAMP PIN	2
16	5530456	AB 3/4" x 4 - 3/4"	16
17	5900160	HDS TRUCK SERIES INSTALLATION MANUAL	1
18	5716633	HDS-18/27/40 CROSSTUBE COVER, PLASTIC	4
19	5716110	TRUCK RUBBER WHEEL CHOCK, SINGLE	2
20	5210242	4 POST HEAVY DUTY CE PARTS BAG	1
21	5930195	ANTI-SLIP TAPE, 6" x 24ft	1

NEXT ASSEMBLY
5260604
5260606

DO NOT SCALE DRAWING

DRAWN	NAME	DATE
TM		05/08/2013
CHECKED		

1445 LEMGONWOOD DR.
SANTA PAULA, CA 93060

BendPak

TITLE: HDS-18E/27 PARTS BOX

SIZE: DWG. NO. 5250172 REV

SCALE: 1:25 SHEET 1 OF 1

THIRD ANGLE PROJECTION

PROPRIETARY AND CONFIDENTIAL
THIS INFORMATION IS UNCLASSIFIED AND IS DRAWN BY
THE SOLE PROPERTY OF BENDPAK INC. ANY
REPRODUCTION OR TRANSMISSION IN ANY FORM OR BY ANY
MEANS WITHOUT THE WRITTEN PERMISSION OF BENDPAK INC. IS
PROHIBITED.

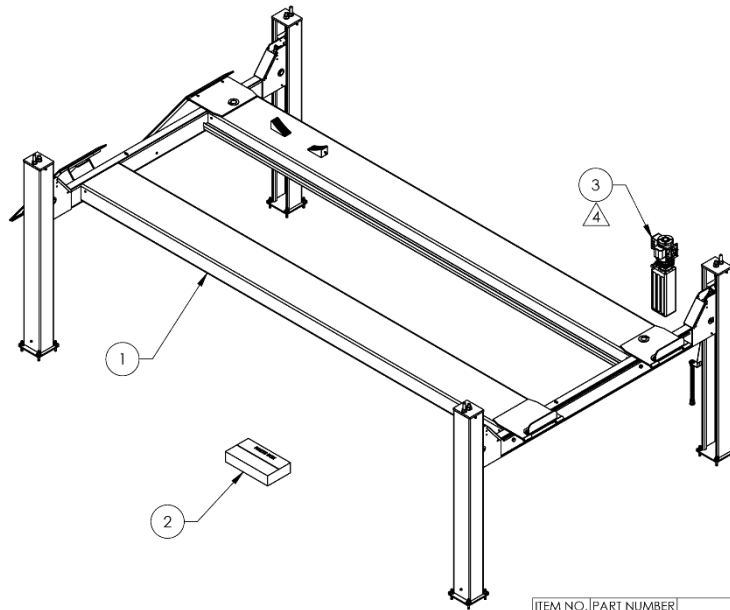

- NOTE: UNLESS OTHERWISE SPECIFIED**
1. REFER TO MODEL FOR ADDITIONAL INFORMATION
 2. SEE SHIPPING INSTRUCTIONS FOR FINAL PACKAGING
 3. SEE COLORS & GRAPHICS FOR LABEL PLACEMENT
 4. POWER UNIT REFERENCE ON PURCHASE ORDER

ITEM NO.	PART NUMBER	DESCRIPTION	QTY.
1	5245090	HDS-27 LIFT SUPERSTRUCTURE	1
2	5250172	HDS-18E/27 PARTS BOX	1
3	REF	POWER UNIT	1

DO NOT SCALE DRAWING		NAME	DATE	 1645 LEMONWOOD DR. SANTA PAULA, CA 93360
DRAWN	TM	12/17/2019		
DIMENSIONS ARE IN MM		THIRD ANGLE PROJECTION		TITLE
				HDS-27 PRODUCTION LIFT VER D (CE CERT)
<small>PROPRIETARY AND CONFIDENTIAL THE INFORMATION CONTAINED HEREIN IS UNCLASSIFIED EXCEPT WHERE SHOWN OTHERWISE AND IS TO BE CONTAINED HEREIN UNLESS SPECIFICALLY NOTED OTHERWISE BY THE ORIGINAL DEVELOPER OR BENDPAK INC. IS NOT TO BE REPRODUCED OR TRANSMITTED IN ANY FORM OR BY ANY MEANS, ELECTRONIC OR MECHANICAL, INCLUDING PHOTOCOPYING, RECORDING, OR BY ANY INFORMATION STORAGE AND RETRIEVAL SYSTEMS.</small>		SIZE	DWG. NO.	REV
		A	5260606	
			SCALE: 1:45	SHEET 1 OF 3

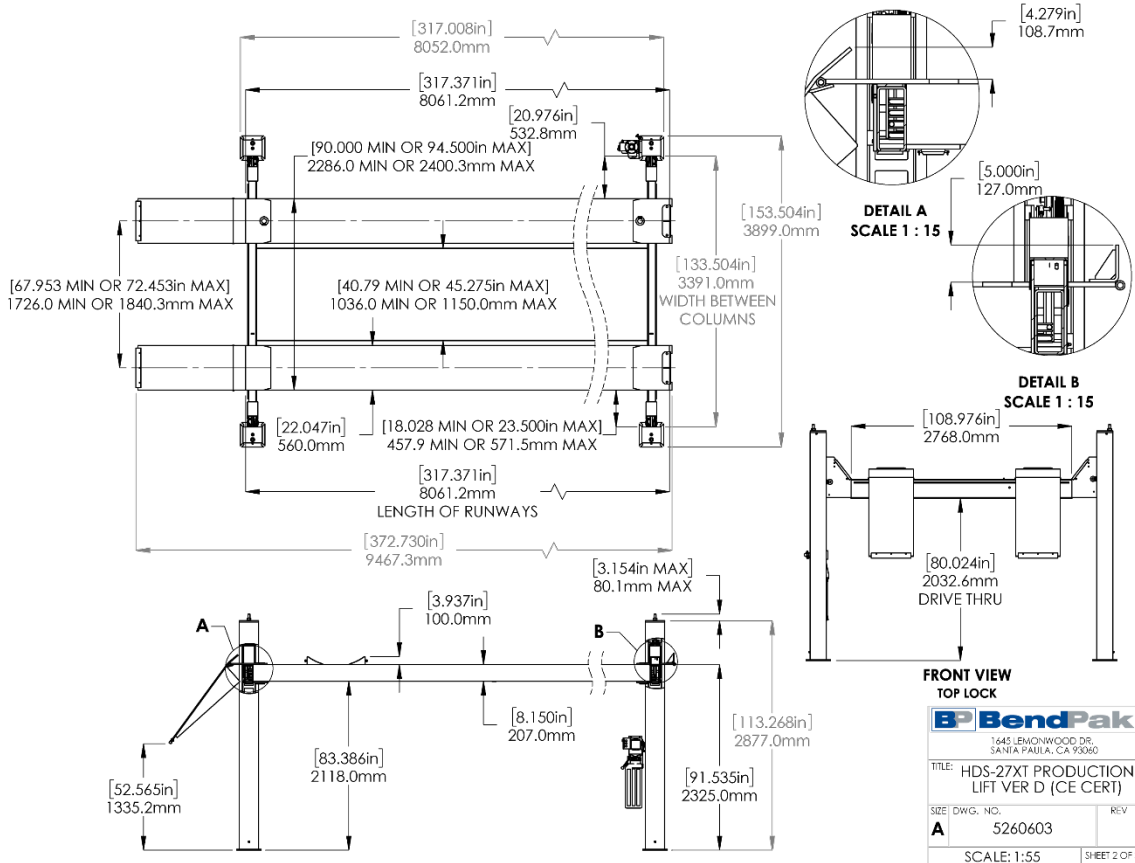

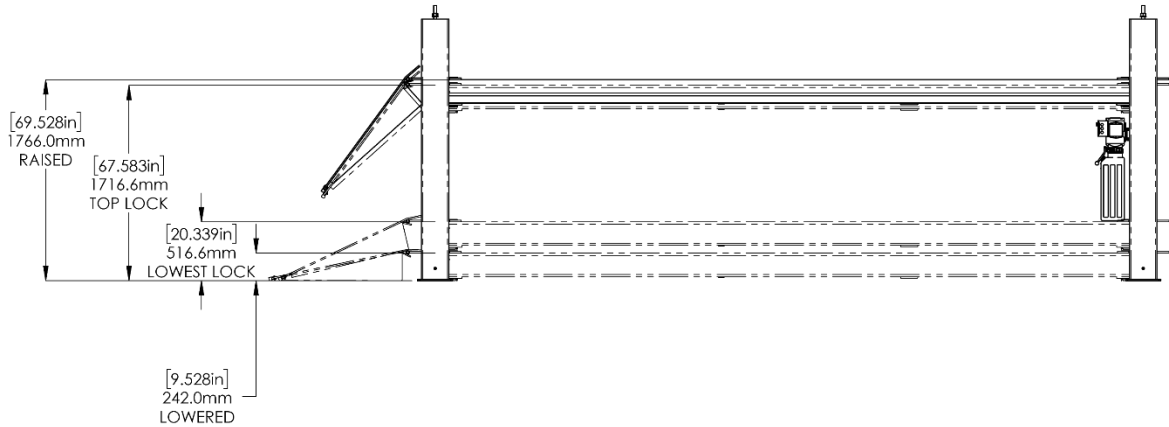

1. DIMENSIONS ARE WITH THE LOCK LADDER ADJUSTED ALL THE WAY UP
2. SAFETY LOCK POSITIONS: 13
3. SPACED EVERY: 100.0mm / 3.937"

BendPak
 1445 LEMONWOOD DR.
 SANTA PAULA, CA 93060

TITLE: HDS-27 PRODUCTION
 LIFT VER D (CE CERT)

SIZE DWG. NO. REV
A 5260606

SCALE: 1:40 SHEET 3 OF 3

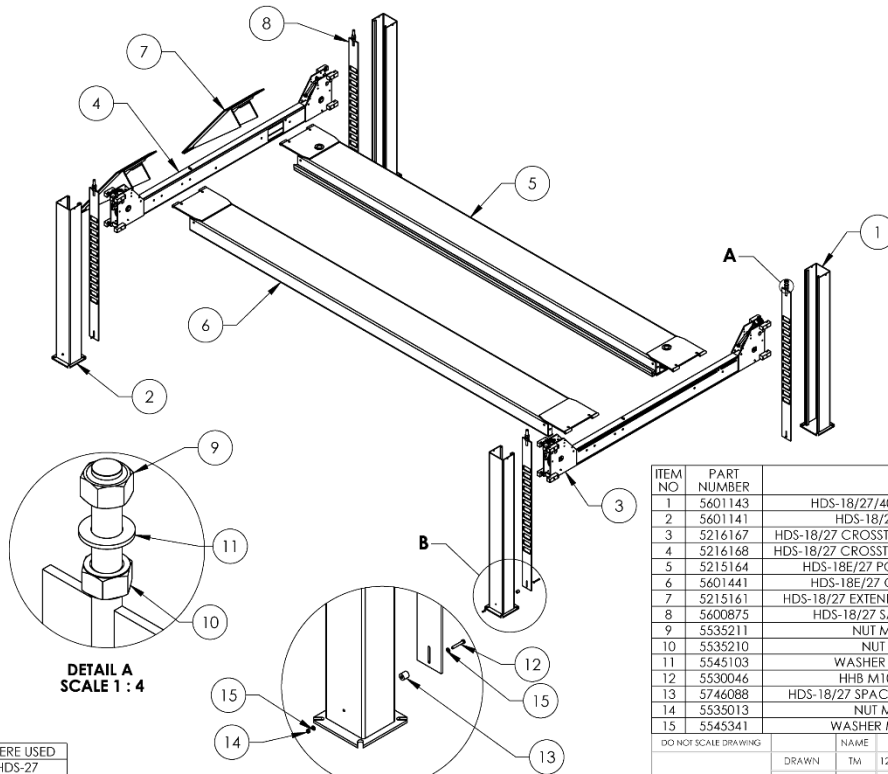

WHERE USED
 HDS-27

- NOTE: UNLESS OTHERWISE SPECIFIED**
1. REFER TO MODEL FOR ADDITIONAL INFORMATION
 2. SEE SHIPPING INSTRUCTIONS FOR FINAL PACKAGING
 3. FASTEN NUTS AND WASHERS TO SAFETY LADDERS IN ORDER SHOWN FOR SHIPMENT

NEXT ASSEMBLY
 5260606

ITEM NO	PART NUMBER	DESCRIPTION	QTY
1	5601143	HDS-18/27/40 POWER POST WELDMENT	1
2	5601141	HDS-18/27/40 POST WELDMENT	3
3	5216167	HDS-18/27 CROSSTUBE ASSEMBLY, SMALL WINDOW	1
4	5216168	HDS-18/27 CROSSTUBE ASSEMBLY, LARGE WINDOW	1
5	5215164	HDS-18E/27 POWER SIDE RAMP ASSEMBLY	1
6	5601441	HDS-18E/27 OFF SIDE RAMP WELDMENT	1
7	5215161	HDS-18/27 EXTENDED DRIVE UP RAMP ASSEMBLY	2
8	5600875	HDS-18/27 SAFETY LADDER WELDMENT	4
9	5535211	NUT M27 x 3.0 NL, CL 10.9	4
10	5535210	NUT M27 x 3.0, CL 10.9	4
11	5545103	WASHER M27 x 50 FLAT, CL 10.9	4
12	5530046	HHB M10 x 1.5 x 65 PT, CL 10.9	4
13	5746088	HDS-18/27 SPACER, SAFETY LADDER, 31mm LG	4
14	5535013	NUT M10 x 1.5 NL, CL10.9	4
15	5545341	WASHER M10 x Ø20 FLAT, CL10.9	8

DO NOT SCALE DRAWING

NAME DATE
 DRAWN TM 12/17/2019

BendPak
 1445 LEMONWOOD DR.
 SANTA PAULA, CA 93060

CHECKED

TITLE: HDS-27 LIFT
 SUPERSTRUCTURE

DIMENSIONS ARE IN MM

THIRD ANGLE PROJECTION

SIZE DWG. NO. REV
A 5245090

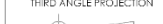

PROPRIETARY AND CONFIDENTIAL
 INFORMATION OF BENDPAK INC. DRAWINGS OR
 MODELS CANNOT BE REPRODUCED OR USED
 FOR ANY OTHER PURPOSES WITHOUT THE
 WRITTEN PERMISSION OF BENDPAK INC.

SCALE: 1:55 SHEET 1 OF 1

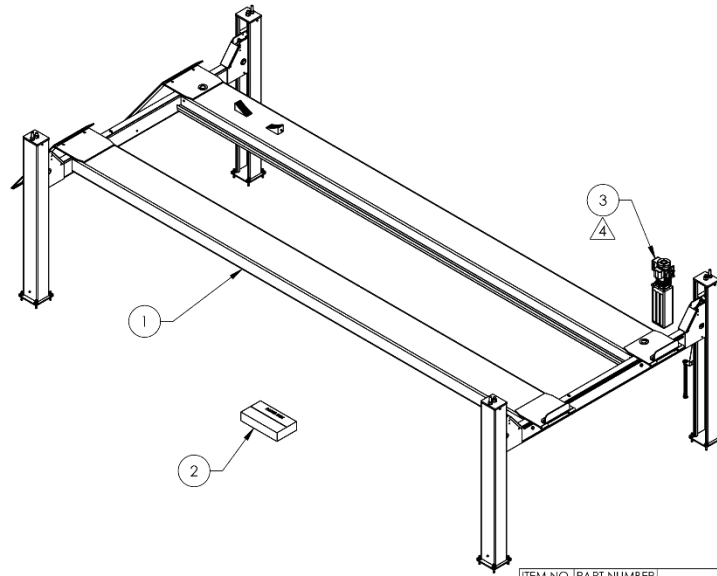

- NOTE: UNLESS OTHERWISE SPECIFIED**
1. REFER TO MODEL FOR ADDITIONAL INFORMATION
 2. SEE SHIPPING INSTRUCTIONS FOR FINAL PACKAGING
 3. SEE COLORS & GRAPHICS FOR LABEL PLACEMENT
 4. POWER UNIT REFERENCE ON PURCHASE ORDER

ITEM NO.	PART NUMBER	DESCRIPTION	QTY.
1	5245086	HDS-27X LIFT SUPERSTRUCTURE	1
2	5250175	HDS-27X PARTS BOX	1
3	REF	POWER UNIT	1

DO NOT SCALE DRAWING	NAME	DATE	BendPak	
DRAWN	CA	12/16/2019	1645 LEMONWOOD DR. SANTA PAULA, CA 93660	
CHECKED			TITLE: HDS-27X PRODUCTION LIFT VER D (CE CERT)	
THIRD ANGLE PROJECTION			SIZE	REV
			A	5260602
<small>PROFESSIONAL AND CERTIFICATION THE BENDPAK GROUP OF COMPANIES IS AN ISO 9001 REGISTERED COMPANY THE BENDPAK GROUP OF COMPANIES IS A MEMBER OF THE BENDPAK GROUP OF COMPANIES THE BENDPAK GROUP OF COMPANIES IS A MEMBER OF THE BENDPAK GROUP OF COMPANIES</small>			SCALE: 1:50	SHEET 1 OF 3

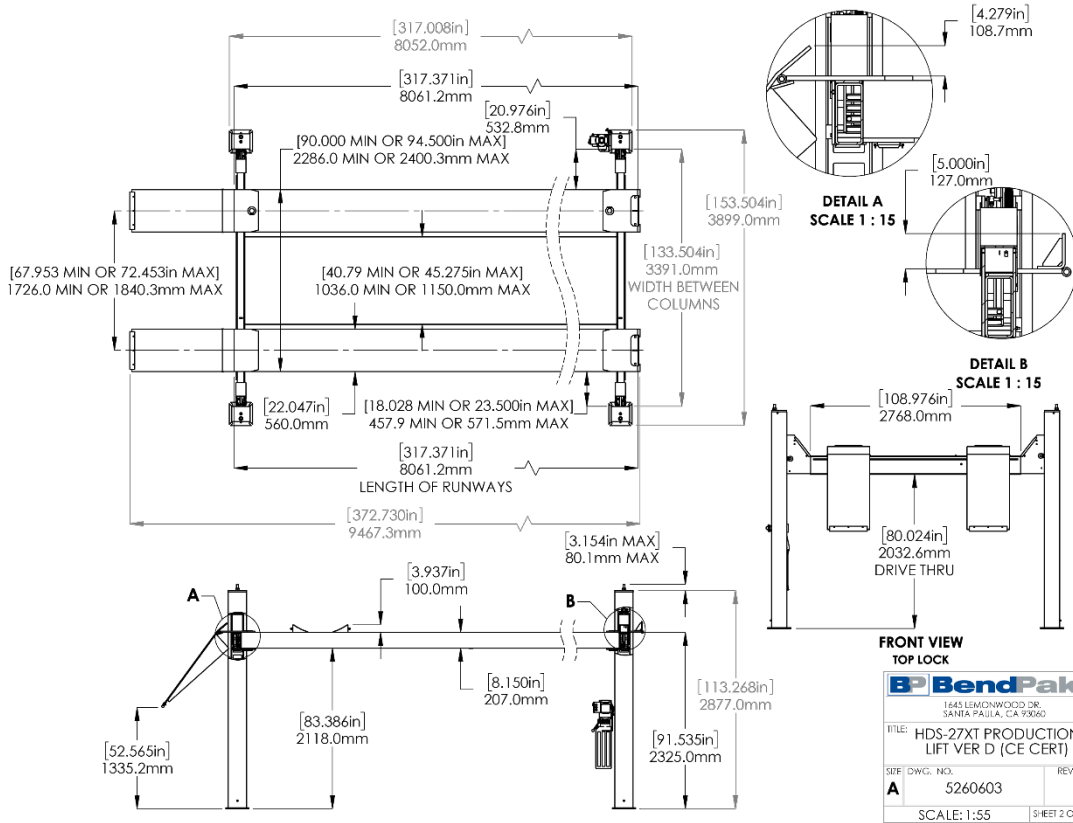

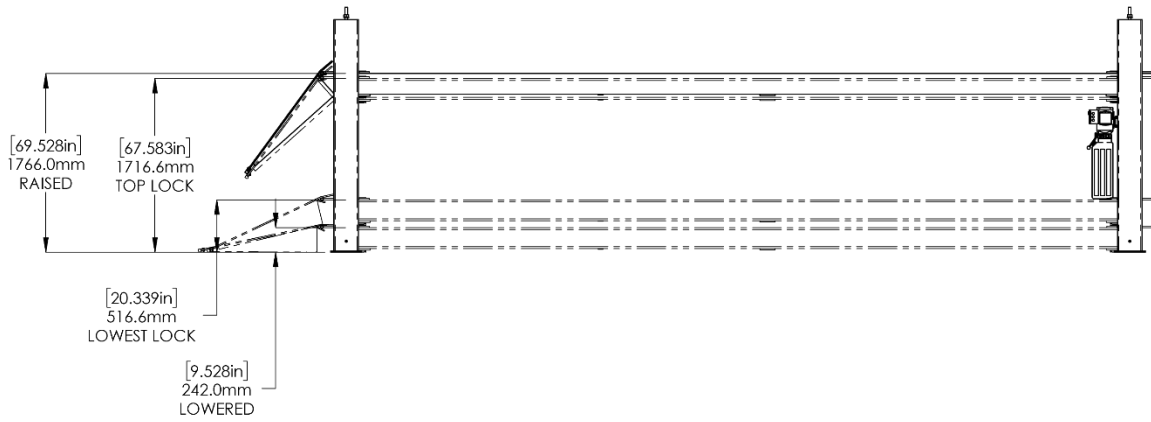

1. DIMENSIONS SHOWN ARE WITH THE LOCK LADDERS ADJUSTED ALL THE WAY UP
2. SAFETY LOCK POSITIONS: 13
3. SPACED EVERY: 100.0mm / 3.937"

BP BendPak.
 1645 LEMONWOOD DR.
 SANTA PAULA, CA 93060

TITLE: HDS-27X PRODUCTION LIFT VER D (CE CERT)

SIZE DWG. NO. 5260602 REV

SCALE: 1:45 SHEET 3 OF 3

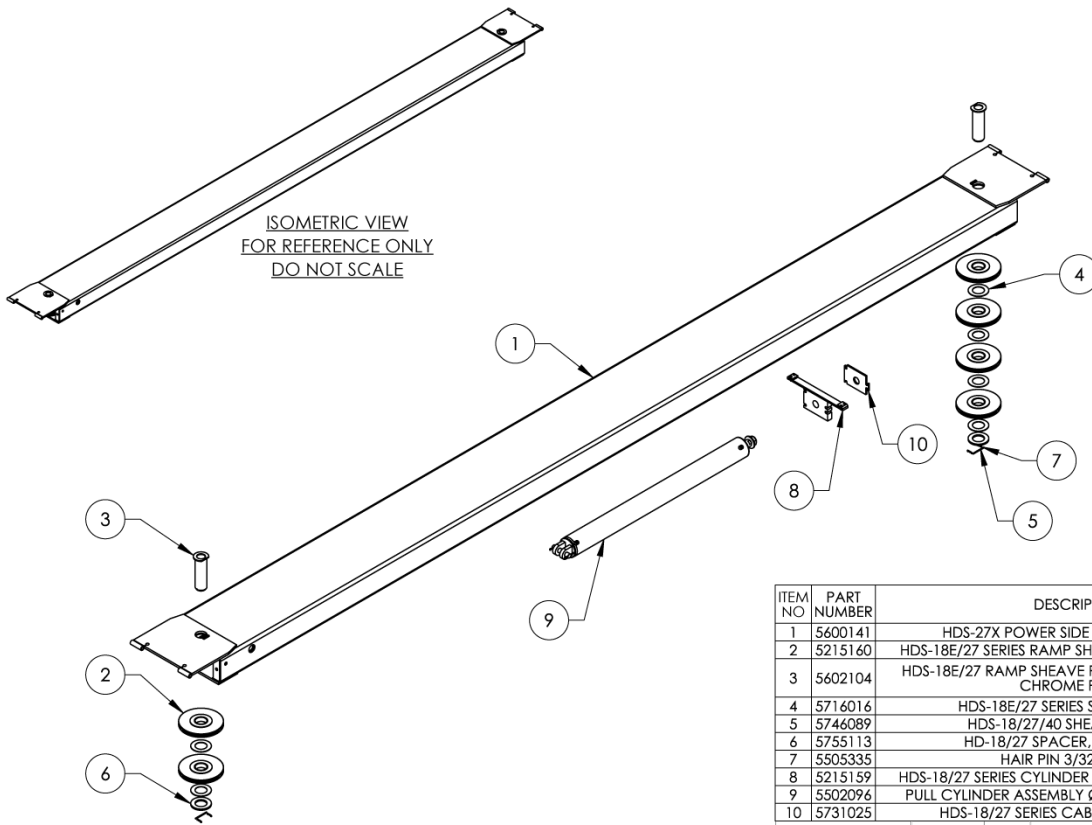

WHERE USED
HDS-27X

NOTE: UNLESS OTHERWISE SPECIFIED

1. REFER TO MODEL FOR ADDITIONAL INFORMATION
2. VERIFY CYLINDER PORTS ARE CAPPED OFF WITH 3/8" NPT STEEL PLUG
3. SEE SHIPPING INSTRUCTIONS FOR FINAL PACKAGING
4. ASSEMBLE ITEMS AS SHOWN

ITEM NO	PART NUMBER	DESCRIPTION	QTY
1	5600141	HDS-27X POWER SIDE RAMP WELDMENT	1
2	5215160	HDS-18E/27 SERIES RAMP SHEAVE ROLLER ASSEMBLY	6
3	5602104	HDS-18E/27 RAMP SHEAVE PIN WELDMENT, Ø80mm CHROME PLATED	2
4	5716016	HDS-18E/27 SERIES SHEAVE SPACER	6
5	5746089	HDS-18/27/40 SHEAVE SHAFT PIN	2
6	5755113	HD-18/27 SPACER, RAMP SHEAVE	2
7	5505335	HAIR PIN 3/32" x 1 5/8"	4
8	5215159	HDS-18/27 SERIES CYLINDER FLANGE ARM ASSEMBLY	1
9	5502096	PULL CYLINDER ASSEMBLY Ø5.0 x 60 - HYDRALOCK	1
10	5731025	HDS-18/27 SERIES CABLE RETAINER PLATE	1

DO NOT SCALE DRAWING

DRAWN GJZ 10/21/2008

CHECKED

DIMENSIONS ARE IN MM

THIRD ANGLE PROJECTION

PROPRIETARY AND CONFIDENTIAL
 THE INFORMATION CONTAINED IN THIS DRAWING IS THE SOLE PROPERTY OF BENDPAK INC. IT IS TO BE USED FOR THE PARTS IDENTIFIED HEREIN ONLY. REPRODUCTION IN ANY FORM OR BY ANY MEANS WITHOUT THE WRITTEN PERMISSION OF BENDPAK INC. IS PROHIBITED.

BP BendPak.
 1645 LEMONWOOD DR.
 SANTA PAULA, CA 93060

TITLE: HDS-27X POWER SIDE RAMP ASSEMBLY

SIZE DWG. NO. 5215157 REV

SCALE: 1:35 SHEET 1 OF 2

NEXT ASSEMBLY
5245086

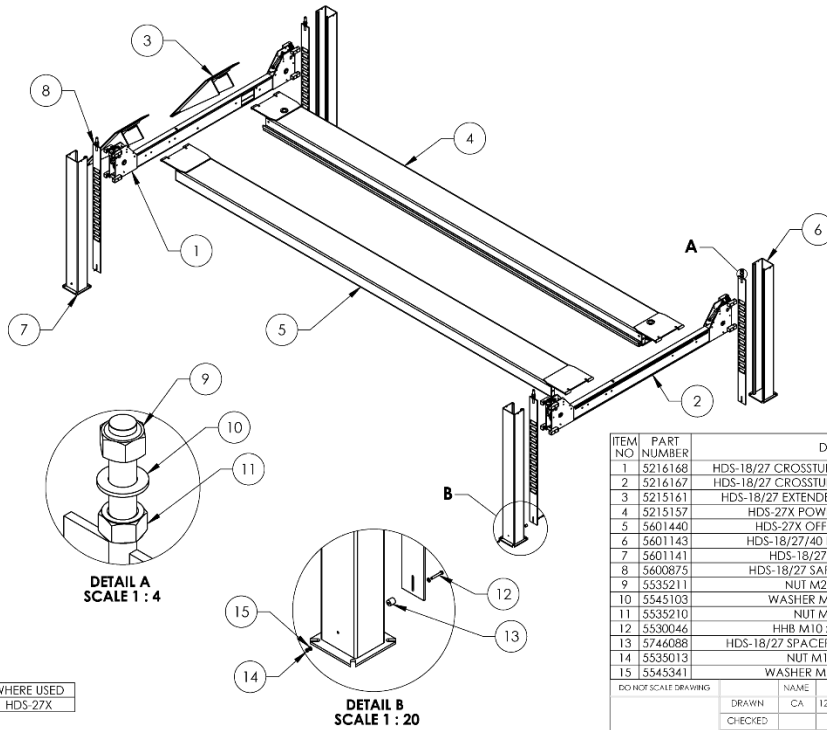

ITEM NO	PART NUMBER	DESCRIPTION	QTY
1	5216168	HDS-18/27 CROSSTUBE ASSEMBLY, LARGE WINDOW	1
2	5216167	HDS-18/27 CROSSTUBE ASSEMBLY, SMALL WINDOW	1
3	5215161	HDS-18/27 EXTENDED DRIVE UP RAMP ASSEMBLY	2
4	5215157	HDS-27X POWER SIDE RAMP ASSEMBLY	1
5	5601440	HDS-27X OFF SIDE RAMP WELDMENT	1
6	5601143	HDS-18/27/40 POWER POST WELDMENT	1
7	5601141	HDS-18/27/40 POST WELDMENT	3
8	5600875	HDS-18/27 SAFETY LADDER WELDMENT	4
9	5535211	NUT M27 x 3.0 NL, CL 10.9	4
10	5545103	WASHER M27 x 30 FLAT, CL 10.9	4
11	5535210	NUT M27 x 3.0, CL 10.9	4
12	5530046	HHB M10 x 1.5 x 45-PT, CL 10.9	4
13	5746088	HDS-18/27 SPACER, SAFETY LADDER, 31mm LG	4
14	5535013	NUT M10 x 1.5 NL, CL 10.9	4
15	5545341	WASHER M10 x Ø20 FLAT, CL 10.9	8

DO NOT SCALE DRAWING

DRAWN: CA DATE: 12/16/2019

CHECKED:

THIRD ANGLE PROJECTION

SMILEY FACE

PROPRIETARY AND CONFIDENTIAL

THE INFORMATION CONTAINED HEREIN IS THE SOLE PROPERTY OF BENDPAK INC. AND IS TO BE USED FOR THE EXCLUSIVE USE OF THE CUSTOMER FOR THE PROJECT SPECIFICALLY IDENTIFIED HEREIN. ANY REPRODUCTION OR TRANSMISSION OF THIS INFORMATION WITHOUT THE WRITTEN PERMISSION OF BENDPAK INC. IS PROHIBITED.

BendPak
1645 LEMORWOOD DR.
SANTA PAULA, CA 95060

TITLE: HDS-27X LIFT SUPERSTRUCTURE

SIZE: A DWG. NO.: 5245086 REV: 1

SCALE: 1:60 SHEET 1 OF 1

NOTE: UNLESS OTHERWISE SPECIFIED

- REFER TO MODEL FOR ADDITIONAL INFORMATION
- SEE SHIPPING INSTRUCTIONS FOR FINAL PACKAGING
- FASTEN NUTS AND WASHERS TO SAFETY LADDERS IN ORDER SHOWN FOR SHIPMENT

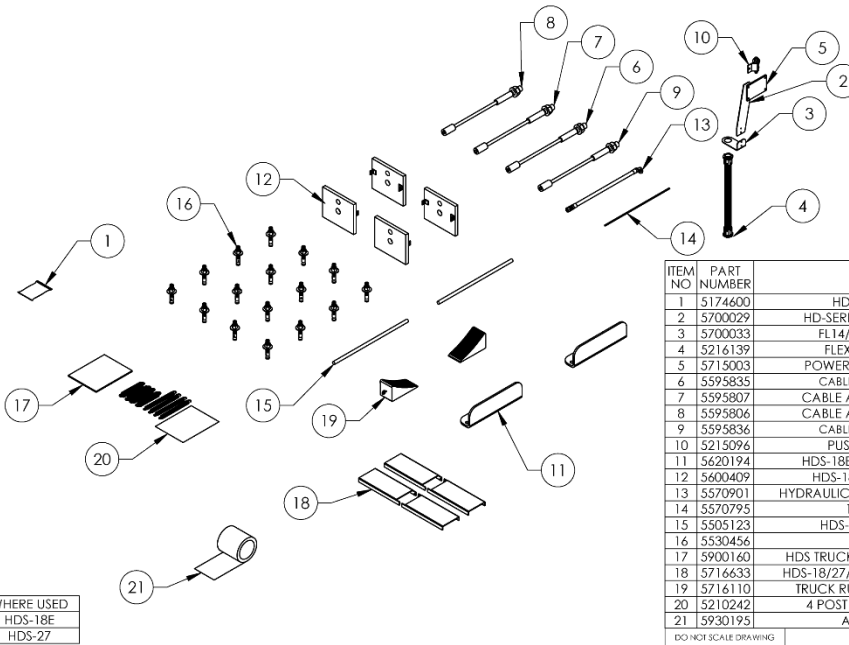

ITEM NO	PART NUMBER	DESCRIPTION	QTY.
1	5174600	HDS-18E/27/40 PARTS BAG	1
2	5700029	HD-SERIES FLEX TUBE BRACKET PLATE	1
3	5700033	FL14/HD/HDS FLEX TUBE ANGLE	1
4	5216139	FLEX TUBE KIT, UP TO 2000mm	1
5	5715003	POWER UNIT VIBRATION DAMPENER	1
6	5595835	CABLE ASSEMBLY Ø16 x 4127mm ST	1
7	5595807	CABLE ASSEMBLY Ø16 x 12215mm ST	1
8	5595806	CABLE ASSEMBLY Ø16 x 10483mm ST	1
9	5595836	CABLE ASSEMBLY Ø16 x 5855mm ST	1
10	5215096	PUSH BUTTON AIR ASSEMBLY	1
11	5620194	HDS-18E/27/40 TIRE STOP WELDMENT	2
12	5600409	HDS-18/27 TOP PLATE WELDMENT	4
13	5570901	HYDRAULIC HOSE ASSEMBLY Ø10 x 5385mm	1
14	5570975	1/4" POLY-FLO TUBING	24000mm*
15	5505123	HDS-18/27 DRIVE UP RAMP PIN	2
16	5530456	AB 3/4" x 4 - 3/4"	16
17	5900160	HDS TRUCK SERIES INSTALLATION MANUAL	1
18	5716633	HDS-18/27/40 CROSSTUBE COVER, PLASTIC	4
19	5716110	TRUCK RUBBER WHEEL CHOCK, SINGLE	2
20	5210242	4 POST HEAVY DUTY CE PARTS BAG	1
21	5930195	ANTI-SLIP TAPE, 6" x 24ft	1

DO NOT SCALE DRAWING

DRAWN: IM DATE: 05/08/2013

CHECKED:

THIRD ANGLE PROJECTION

SMILEY FACE

PROPRIETARY AND CONFIDENTIAL

THE INFORMATION CONTAINED HEREIN IS THE SOLE PROPERTY OF BENDPAK INC. AND IS TO BE USED FOR THE EXCLUSIVE USE OF THE CUSTOMER FOR THE PROJECT SPECIFICALLY IDENTIFIED HEREIN. ANY REPRODUCTION OR TRANSMISSION OF THIS INFORMATION WITHOUT THE WRITTEN PERMISSION OF BENDPAK INC. IS PROHIBITED.

BendPak
1645 LEMORWOOD DR.
SANTA PAULA, CA 95060

TITLE: HDS-18E/27 PARTS BOX

SIZE: A DWG. NO.: 5250172 REV: 1

SCALE: 1:25 SHEET 1 OF 1

NOTE: UNLESS OTHERWISE SPECIFIED

- REFER TO MODEL FOR ADDITIONAL INFORMATION
- SEE SHIPPING INSTRUCTIONS FOR FINAL PACKAGING
- HOSES AND CABLES IN REPRESENTATIONAL FORM
- (*) LENGTH FOR REFERENCE ONLY

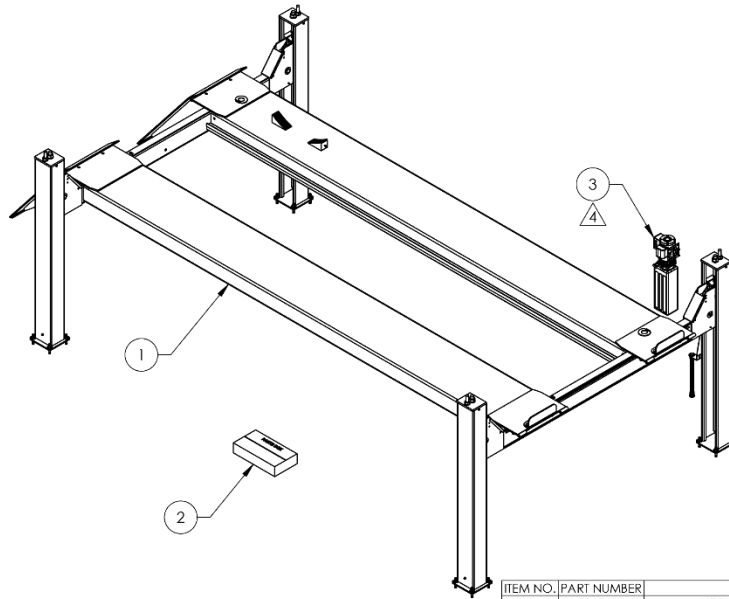

ITEM NO.	PART NUMBER	DESCRIPTION	QTY.
1	5245091	HDS-40 LIFT SUPERSTRUCTURE	1
2	5250079	HDS-40 PARTS BOX	1
3	REF	POWER UNIT	1

DO NOT SCALE DRAWING	NAME	DATE	 1645 LEMONWOOD DR. SANTA PAULA, CA 93060
DIMENSIONS ARE IN MM	DRAWN TM	12/17/2019	
 THIRD ANGLE PROJECTION	CHECKED		TITLE
			HDS-40 PRODUCTION LIFT VER D (CE CERT)
PROPRIETARY AND CONFIDENTIAL THE INFORMATION CONTAINED HEREIN IS THE PROPERTY OF BENDPAK, INC. AND IS TO BE KEPT CONFIDENTIAL BY ALL TO WHOM IT IS FURNISHED. PERMISSION TO REPRODUCE IS NOT GRANTED WITHOUT THE WRITTEN PERMISSION OF BENDPAK, INC.		SIZE	REV
		A	5260607
		SCALE: 1:45 SHEET 1 OF 3	

NOTE: UNLESS OTHERWISE SPECIFIED

1. REFER TO MODEL FOR ADDITIONAL INFORMATION
2. SEE SHIPPING INSTRUCTIONS FOR FINAL PACKAGING
3. SEE COLORS & GRAPHICS FOR LABEL PLACEMENT
4. POWER UNIT REFERENCE ON PURCHASE ORDER

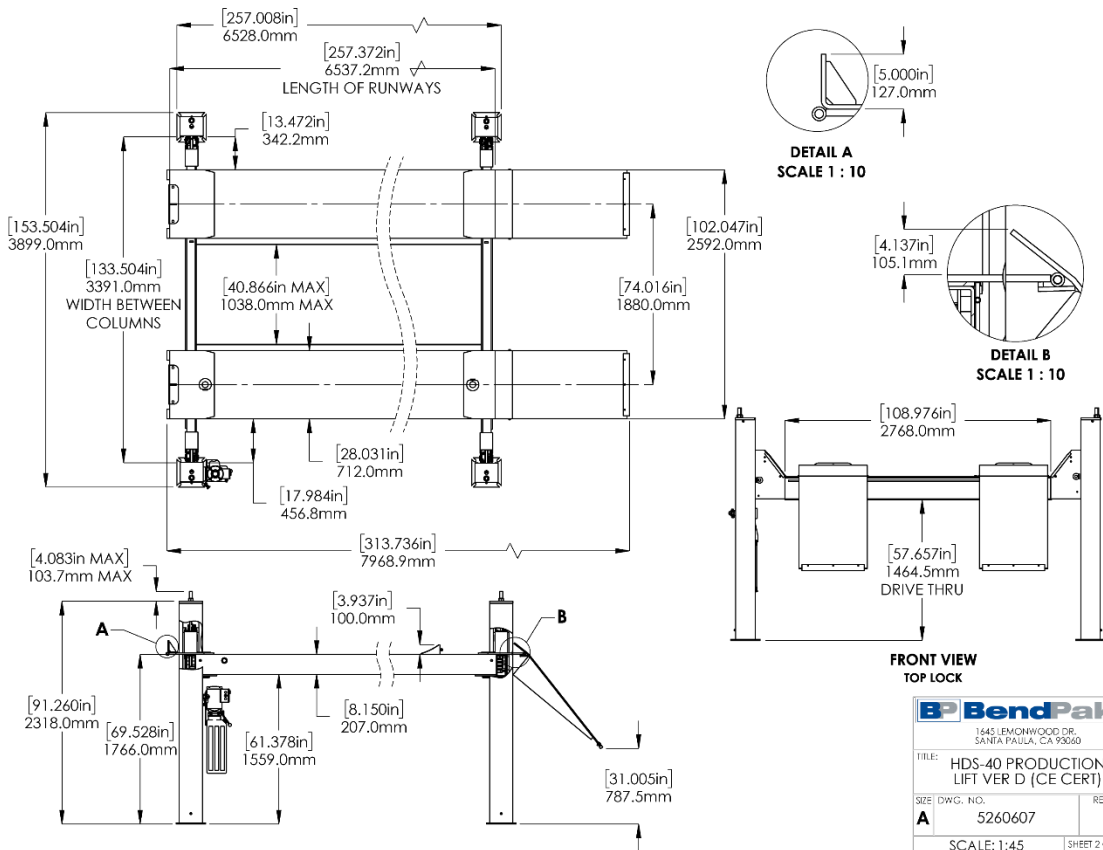

 1645 LEMONWOOD DR. SANTA PAULA, CA 93060	
TITLE	
HDS-40 PRODUCTION LIFT VER D (CE CERT)	
SIZE	REV
A	5260607
SCALE: 1:45 SHEET 2 OF 3	

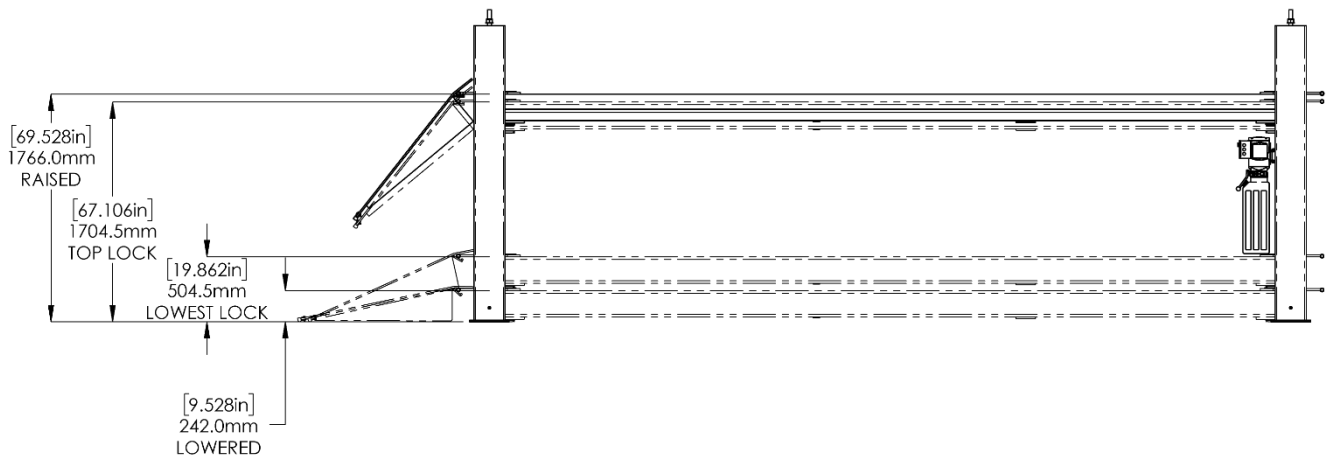

1. ALL DIMENSIONS SHOWN ARE WITH LOCK LADDER ADJUSTED ALL THE WAY UP
2. SAFETY LOCK POSITIONS: 13
3. SPACED EVERY: 100.0mm / 3.937"

BendPak
 1645 LEMONWOOD DR.
 SANTA PAULA, CA 93060

TITLE: HDS-40 PRODUCTION LIFT VER D (CE CERT)

SIZE DWG. NO. 5260607 REV

SCALE: 1:40 SHEET 3 OF 3

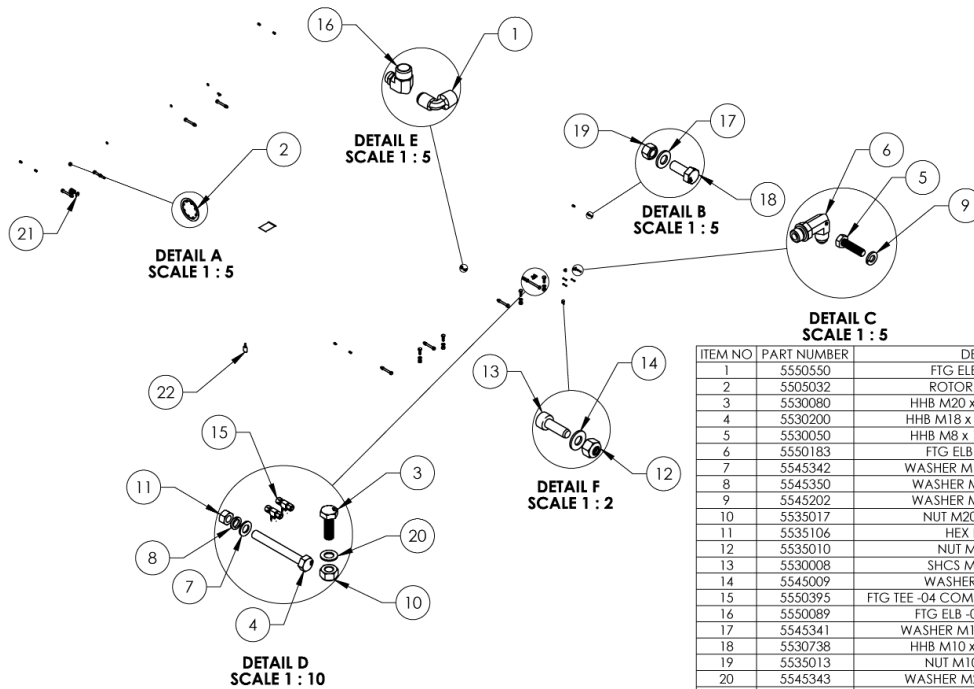

ITEM NO	PART NUMBER	DESCRIPTION	QTY
1	5550550	FTG ELB -06 JIC -06 NPT	1
2	5505032	ROTOR CLIP Ø18mm SS	4
3	5530080	HHB M20 x 2.5 x 60 FT, CL 10.9	4
4	5530200	HHB M18 x 2.5 x 150 FT, CL 10.9	8
5	5530050	HHB M8 x 1.25 x 30 FT, CL 10.9	4
6	5550183	FTG ELB -06 JIC -06L ORB	1
7	5545342	WASHER M18 x 34 FLAT, CL 10.9	8
8	5545350	WASHER M18 x 28 SL, CL 10.9	8
9	5545202	WASHER M8 x Ø15 SL, CL10.9	4
10	5535017	NUT M20 x 2.5 NL, CL 10.9	4
11	5535106	HEX NUT M18 x 2.5	8
12	5535010	NUT M4 x 0.7, NL CL8	2
13	5530008	SHCS M4 x 0.7 x 12 BOC	2
14	5545009	WASHER, M4 x 9mm FLAT	2
15	5550395	FTG TEE -04 COMP x -04 COMP x -04 COMP	3
16	5550089	FTG ELB -04 COMP x -06 NPT	2
17	5545341	WASHER M10 x Ø20 FLAT, CL10.9	8
18	5530738	HHB M10 x 1.5 x 25 FT, CL 10.9	8
19	5535013	NUT M10 x 1.5 NL, CL10.9	8
20	5545343	WASHER M20 x 37 FLAT, CL 10.9	4
21	5545535	C WASHER SHIM FOR LIFTS	20
22	5580012	LIQUID PTFE THREAD SEALANT 50ml	1

WHERE USED
 HDS-18E
 HDS-27 SERIES
 HDS-40 SERIES

NOTE: UNLESS OTHERWISE SPECIFIED
 1. SEE SHIPPING INSTRUCTIONS FOR FINAL PACKAGING

NEXT ASSEMBLY

5250079
5250082
5250172
5250175
5250364
5250388

DO NOT SCALE DRAWING

DRAWN AC 05/06/2009

CHECKED

THIRD ANGLE PROJECTION

PROPRIETARY AND CONFIDENTIAL
 THE INFORMATION CONTAINED IN THIS DRAWING IS THE SOLE PROPERTY OF BENDPAK INC. ANY REPRODUCTION OR TRANSMISSION OF THIS DRAWING WITHOUT THE WRITTEN PERMISSION OF BENDPAK INC. IS PROHIBITED.

BendPak
 1645 LEMONWOOD DR.
 SANTA PAULA, CA 93060

TITLE: HDS-18E/27/40 PARTS BAG

SIZE: DWG. NO. 5174600 REV

SCALE: 1:50 SHEET 1 OF 1

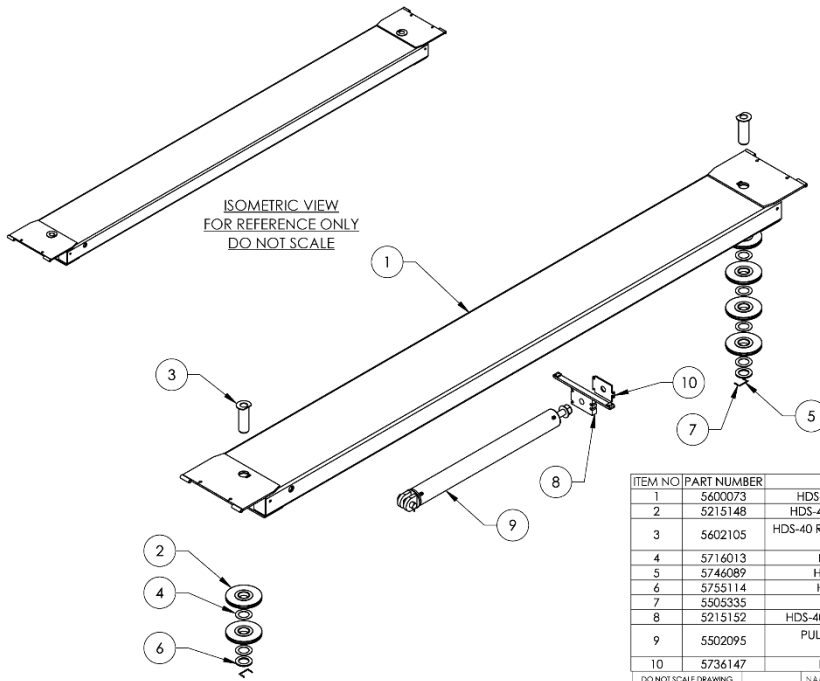

WHERE USED
HDS-40

NOTE: UNLESS OTHERWISE SPECIFIED

1. REFER TO MODEL FOR ADDITIONAL INFORMATION
2. VERIFY CYLINDER PORTS ARE CAPPED OFF WITH 3/8" NPT STEEL PLUG
3. SEE SHIPPING INSTRUCTIONS FOR FINAL PACKAGING
4. ASSEMBLE ITEMS AS SHOWN

NEXT ASSEMBLY
5245091

ITEM NO	PART NUMBER	DESCRIPTION	QTY
1	5600073	HDS-40 POWER SIDE RAMP WELDMENT	1
2	5215148	HDS-40 RAMP SHEAVE ROLLER ASSEMBLY	6
3	5602105	HDS-40 RAMP SHEAVE PIN WELDMENT, Ø85mm CHROME PLATED	2
4	5716013	HDS-40 SERIES SHEAVE SPACER	6
5	5746089	HDS-18/27/40 SHEAVE SHAFT PIN	2
6	5755114	HDS-40 SPACER, RAMP SHEAVE	2
7	5505335	HAIR PIN 3/32" x 1 5/8"	4
8	5215152	HDS-40 CYLINDER FLANGE ARM ASSEMBLY	1
9	5502095	PULL CYLINDER ASSEMBLY Ø5.5 x 60 - HYDRALOCK	1
10	5736147	HDS-40 CABLE RETAINER PLATE	1

DO NOT SCALE DRAWING

DRAWN: GJZ DATE: 10/17/2008

CHECKED:

DIMENSIONS ARE IN INCH

THIRD ANGLE PROJECTION

SMILEY FACE

PROPRIETARY AND CONFIDENTIAL
ALL RIGHTS RESERVED BY BENDPAK INC. REPRODUCTION IN ANY MANNER WITHOUT THE WRITTEN PERMISSION OF BENDPAK INC. IS PROHIBITED.

BendPak
1645 LEMMONWOOD DR.
SANTA PAULA, CA 95060

TITLE: HDS-40 POWER SIDE RAMP ASSEMBLY

SIZE: DWG. NO. 5215240

SCALE: 1:35

SHEET 1 OF 2

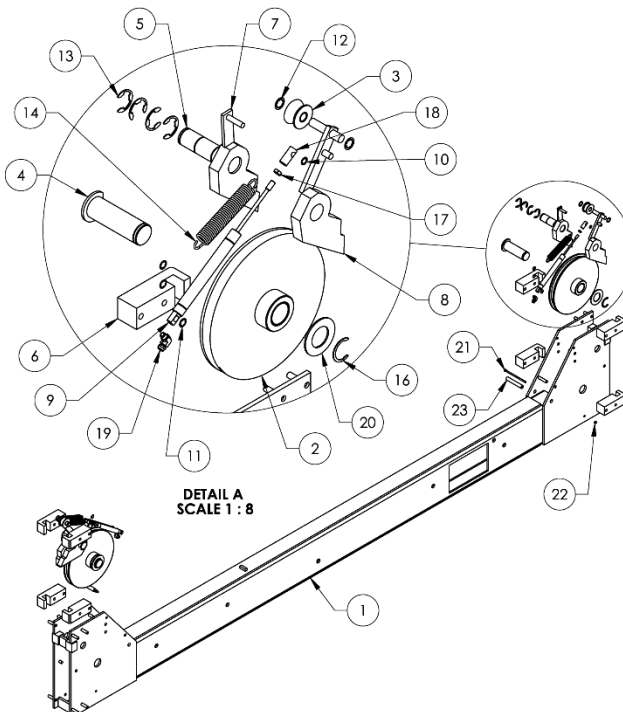

WHERE USED
HDS-40 SERIES

NOTE: UNLESS OTHERWISE SPECIFIED

1. REFER TO MODEL FOR ADDITIONAL INFORMATION
2. SEE SHIPPING INSTRUCTIONS FOR FINAL PACKAGING
3. ASSEMBLE ITEMS AS SHOWN

NEXT ASSEMBLY
5245076
5245091
5245092

ITEM NO	PART NUMBER	DESCRIPTION	QTY
1	5601833	HDS-40 CROSSTUBE WELDMENT, LARGE WINDOW	1
2	5215139	HDS-40 CROSSTUBE SHEAVE ASSEMBLY	2
3	5215143	HDS-40 SAFETY ROLLER ASSEMBLY	2
4	5602100	4 POST HEAVY DUTY CROSSTUBE SHEAVE PIN WELDMENT, Ø44mm	2
5	5505125	HDS-18/27/40 SAFETY PIN	2
6	5716043	HDS-40 POLYETHYLENE SLIDE BLOCK	8
7	5210359	HDS-18/27/40 SAFETY WELDMENT #1	2
8	5210358	HDS-18/27/40 SAFETY WELDMENT #2	2
9	5502335	AIR CYLINDER, Ø.75 x 4.0" STROKE	2
10	5505030	PUSH-ON CLIP Ø10mm SS	3
11	5505031	ROTOR CLIP Ø12mm SS	6
12	5505033	PUSH-ON CLIP Ø16mm SS	4
13	5540002	E RING Ø1.375" OD TRUARC X51133-137	8
14	5540060	SPRING Ø29 x 178mm, SLACK SAFETY	3
15	5540055	SPRING Ø19 x 241mm, AIR CYLINDER	1
16	5540112	SNAP RING; TRUARC S103-175	2
17	5535101	3/8-16 HEX NUT JAM	2
18	5550376	HDS-18/27/40 ADAPTER, 1" AIR CYLINDER	2
19	5550087	FTG ELB -04 COMP x -02 NPT	2
20	5545108	WASHER M45 x 80 FLAT	2
21	5530317	HHB M6 x 1 x 136	2
22	5535357	NUT M6 x 1.0 NL CL10.9	2
23	5755158	CROSSTUBE END PLATE SPACER, 102mm	2

DO NOT SCALE DRAWING

DRAWN: TM DATE: 05/03/2022

CHECKED:

DIMENSIONS ARE IN INCH

THIRD ANGLE PROJECTION

SMILEY FACE

PROPRIETARY AND CONFIDENTIAL
ALL RIGHTS RESERVED BY BENDPAK INC. REPRODUCTION IN ANY MANNER WITHOUT THE WRITTEN PERMISSION OF BENDPAK INC. IS PROHIBITED.

BendPak
1645 LEMMONWOOD DR.
SANTA PAULA, CA 95060

TITLE: HDS-40 CROSSTUBE ASSEMBLY, LARGE WINDOW

SIZE: DWG. NO. 5216169

SCALE: 1:20

SHEET 1 OF 1

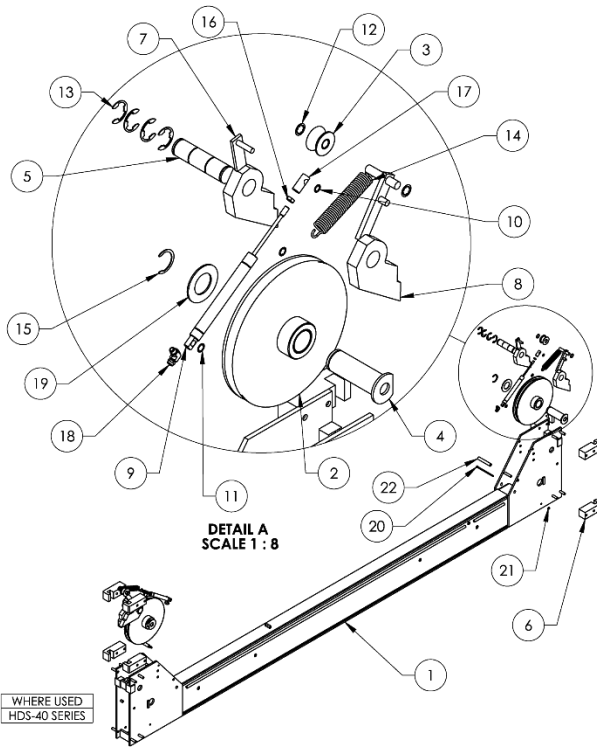

ITEM NO	PART NUMBER	DESCRIPTION	QTY
1	5601834	HDS-40 CROSSTUBE WELDMENT, SMALL WINDOW	1
2	5215139	HDS-40 CROSSTUBE SHEAVE ASSEMBLY	2
3	5215143	HDS-40 SAFETY ROLLER ASSEMBLY	2
4	5602100	4 POST HEAVY DUTY CROSSTUBE SHEAVE PIN WELDMENT, Ø24mm	2
5	5505125	HDS-18/27/40 SAFETY PIN	2
6	5716043	HDS-40 POLYETHYLENE SLIDE BLOCK	8
7	5210359	HDS-18/27/40 SAFETY WELDMENT #1	2
8	5210358	HDS-18/27/40 SAFETY WELDMENT #2	2
9	5502335	AIR CYLINDER, Ø.75 x 4.0" STROKE	2
10	5505030	PUSH-ON CLIP Ø10mm SS	2
11	5505031	ROTOR CLIP Ø12mm SS	4
12	5505033	PUSH-ON CLIP Ø16mm SS	4
13	5540002	E RING Ø1.375" OD TRUARC X5133-137	8
14	5540060	SPRING Ø29 x 178mm, SLACK SAFETY	2
15	5540112	SNAP RING; TRUARC 5103-175	2
16	5535101	3/8-16 HEX NUT JAM	2
17	5550376	HDS-18/27/40 ADAPTER, 1" AIR CYLINDER	2
18	5550087	FIG ELB -04 COMP x -02 NPT	2
19	5545108	WASHER M45 x 80 FLAT	2
20	5530317	HHB M6 x 1 x 136	2
21	5535357	NUT M6 x 1.0 NL, CL10.9	2
22	5755158	CROSSTUBE END PLATE SPACER, 102mm	2

NOTE: UNLESS OTHERWISE SPECIFIED

1. REFER TO MODEL FOR ADDITIONAL INFORMATION
2. SEE SHIPPING INSTRUCTIONS FOR FINAL PACKAGING
3. ASSEMBLE ITEMS AS SHOWN

NEXT ASSEMBLY
5245076
5245091
5245092

DO NOT SCALE DRAWING

DRAWN: TM 05/03/2022
CHECKED: [Signature]

THIRD ANGLE PROJECTION

PROPRIETARY AND CONFIDENTIAL
THE INFORMATION CONTAINED HEREIN IS THE PROPERTY OF BENDPAK INC.
REPRODUCTION IN WHOLE OR IN PART WITHOUT THE WRITTEN PERMISSION OF BENDPAK INC. IS PROHIBITED.

BendPak
1445 LEMONWOOD DR.
SANTA PAULA, CA 93060

TITLE: HDS-40 CROSSTUBE ASSEMBLY, SMALL WINDOW

SIZE: DWG. NO. A 5216170

SCALE: 1:25 SHEET 1 OF 1

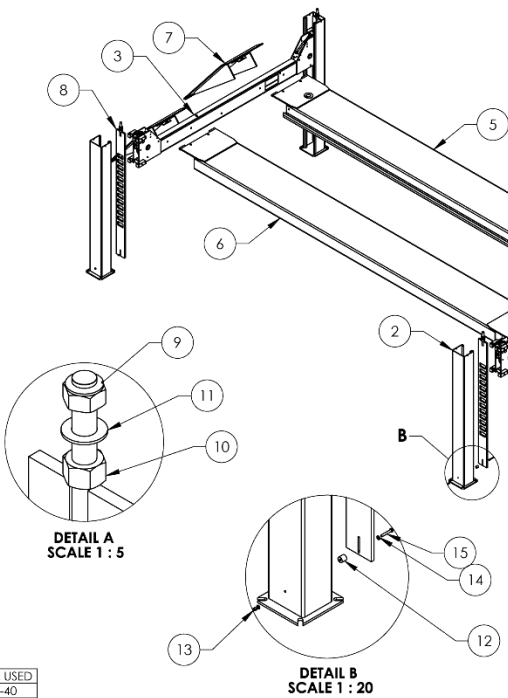

ITEM NO	PART NUMBER	DESCRIPTION	QTY
1	5601143	HDS-18/27/40 POWER POST WELDMENT	1
2	5601141	HDS-18/27/40 POST WELDMENT	3
3	5216169	HDS-40 CROSSTUBE ASSEMBLY, LARGE WINDOW	1
4	5216170	HDS-40 CROSSTUBE ASSEMBLY, SMALL WINDOW	1
5	5215240	HDS-40 POWER SIDE RAMP ASSEMBLY	1
6	5601447	HDS-40 OFF SIDE RAMP WELDMENT	1
7	5215162	HDS-40 EXTENDED DRIVE UP RAMP ASSEMBLY	2
8	5601246	HDS-40 SAFETY LADDER WELDMENT	4
9	5535104	NUT M30 x 3.5 NL	4
10	5535212	NUT M30 x 3.5	4
11	5545415	WASHER M30 x 56 FLAT	4
12	5746369	HDS-40 SPACER, SAFETY LADDER, 30mm LG	4
13	5535013	NUT M10 x 1.5 NL, CL10.9	4
14	5545341	WASHER M10 x Ø20 FLAT, CL10.9	8
15	5530046	HHB M10 x 1.5 x 65 PT, CL 10.9	4

NOTE: UNLESS OTHERWISE SPECIFIED

1. REFER TO MODEL FOR ADDITIONAL INFORMATION
2. SEE SHIPPING INSTRUCTIONS FOR FINAL PACKAGING
3. FASTEN NUTS AND WASHERS TO SAFETY LADDERS IN ORDER SHOWN FOR SHIPMENT

NEXT ASSEMBLY
5260607

DO NOT SCALE DRAWING

DRAWN: TM 12/17/2019
CHECKED: [Signature]

THIRD ANGLE PROJECTION

PROPRIETARY AND CONFIDENTIAL
THE INFORMATION CONTAINED HEREIN IS THE PROPERTY OF BENDPAK INC.
REPRODUCTION IN WHOLE OR IN PART WITHOUT THE WRITTEN PERMISSION OF BENDPAK INC. IS PROHIBITED.

BendPak
1445 LEMONWOOD DR.
SANTA PAULA, CA 93060

TITLE: HDS-40 LIFT SUPERSTRUCTURE

SIZE: DWG. NO. A 5245091

SCALE: 1:60 SHEET 1 OF 1

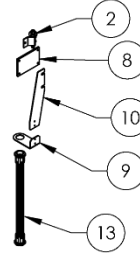
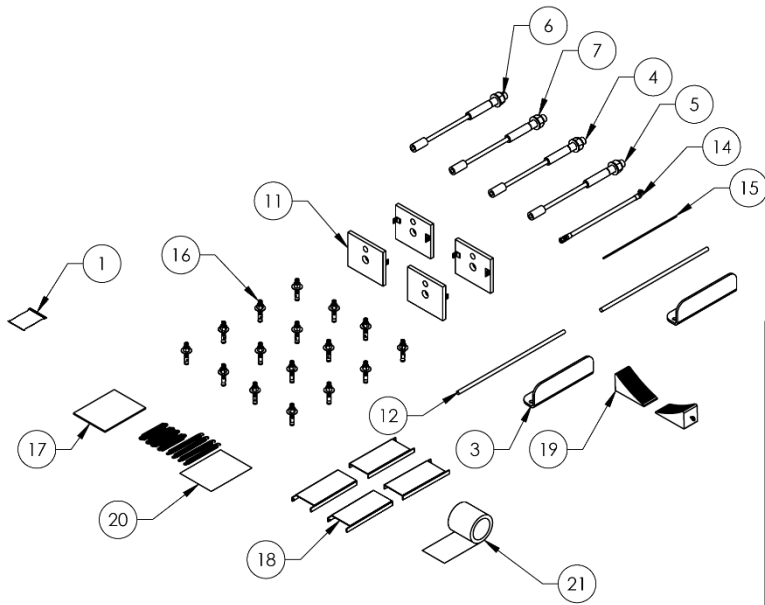

WHERE USED
HDS-40

NOTE: UNLESS OTHERWISE SPECIFIED:

1. REFER TO MODEL FOR ADDITIONAL INFORMATION
2. SEE SHIPPING INSTRUCTIONS FOR FINAL PACKAGING
3. HOSES AND CABLES IN REPRESENTATIONAL FORM
4. (*) LENGTH FOR REFERENCE ONLY

NEXT ASSEMBLY
5260607

ITEM NO.	PART NUMBER	DESCRIPTION	QTY.
1	5174600	HDS-18E/27/40 PARTS BAG	1
2	5215096	PUSH BUTTON AIR ASSEMBLY	1
3	5620194	HDS-18E/27/40 TIRE STOP WELDMENT	2
4	5595558	HDS-40 CABLE ASSEMBLY Ø19 x 4102mm ST	1
5	5595559	HDS-40 CABLE ASSEMBLY Ø19 x 5836mm ST	1
6	5595564	HDS-40 CABLE ASSEMBLY Ø19 x 10452mm ST	1
7	5595565	HDS-40 CABLE ASSEMBLY Ø19 x 12167mm ST	1
8	5715003	POWER UNIT VIBRATION DAMPENER	1
9	5700033	FL14/HD/HDS FLEX TUBE ANGLE	1
10	5700029	HD-SERIES FLEX TUBE BRACKET PLATE	1
11	5600410	HDS-40 TOP PLATE WELDMENT	4
12	5505129	HDS-40 HINGE PIN	2
13	5216139	FLEX TUBE KIT, UP TO 2000mm	1
14	5570149	HDS-40 HYDRAULIC HOSE ASSY Ø10 x 5385mm	1
15	5570795	1/4" POLY-FLO TUBING	24000mm*
16	5530456	AB 3/4" x 4 - 3/4"	16
17	5900160	HDS TRUCK SERIES INSTALLATION MANUAL	1
18	5716633	HDS-18/27/40 CROSSTUBE COVER, PLASTIC	4
19	5716110	TRUCK RUBBER WHEEL CHOCK, SINGLE	2
20	5210242	4 POST HEAVY DUTY CE PARTS BAG	1
21	5930195	ANTI-SLIP TAPE, 6" x 24ft	1

DO NOT SCALE DRAWING		NAME	DATE
DRAWN	TS	10/02/2018	
CHECKED			
DIMENSIONS ARE IN MM		THIRD ANGLE PROJECTION	
		TITLE: HDS-40 PARTS BOX	
		SIZE: DWG. NO. A 5250079	REV
<small>PROPRIETARY AND CONFIDENTIAL THE INFORMATION CONTAINED IN THIS DRAWING IS THE SOLE PROPERTY OF BENDPAK INC. ANY REPRODUCTION IN WHOLE OR IN PART WITHOUT THE WRITTEN PERMISSION OF BENDPAK INC. IS PROHIBITED.</small>		SCALE: 1:25 SHEET 1 OF 1	

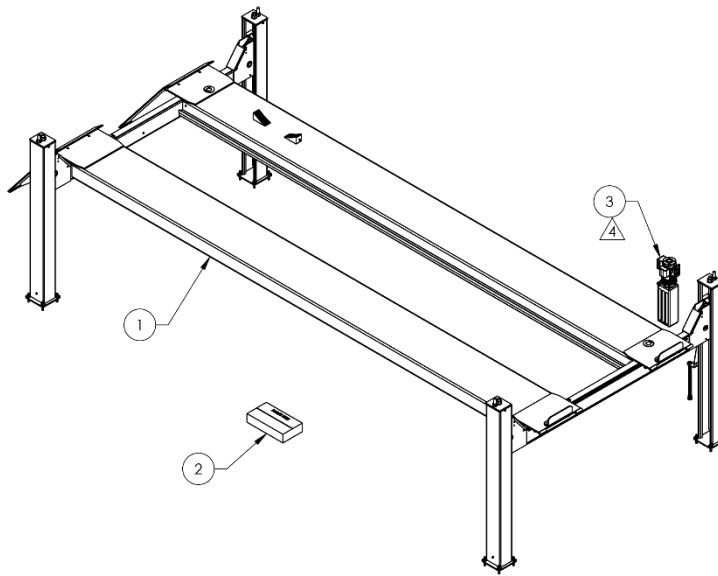

ITEM NO.	PART NUMBER	DESCRIPTION	QTY.
1	5245092	HDS-40X LIFT SUPERSTRUCTURE	1
2	5250082	HDS-40X PARTS BOX	1
3	REF	POWER UNIT	1

DO NOT SCALE DRAWING

DRAWN	IM	DATE	12/18/2019
CHECKED			
THIRD ANGLE PROJECTION			
<small>PROPRIETARY AND CONFIDENTIAL THE INFORMATION CONTAINED HEREIN IS THE PROPERTY OF BENDPAK INC. AND IS NOT TO BE REPRODUCED OR TRANSMITTED IN ANY FORM OR BY ANY MEANS, ELECTRONIC OR MECHANICAL, WITHOUT THE WRITTEN PERMISSION OF BENDPAK INC.</small>			
TITLE: HDS-40X PRODUCTION LIFT VER D (CE CERT)		1445 ELMONWOOD DR. SANTA PAULA, CA 93060	
SIZE	DWG. NO.	REV	
A	5260608		
SCALE: 1:50		SHEET 1 OF 3	

NOTE: UNLESS OTHERWISE SPECIFIED

1. REFER TO MODEL FOR ADDITIONAL INFORMATION
2. SEE SHIPPING INSTRUCTIONS FOR FINAL PACKAGING
3. SEE COLORS & GRAPHICS FOR LABEL PLACEMENT
4. POWER UNIT REFERENCE ON PURCHASE ORDER

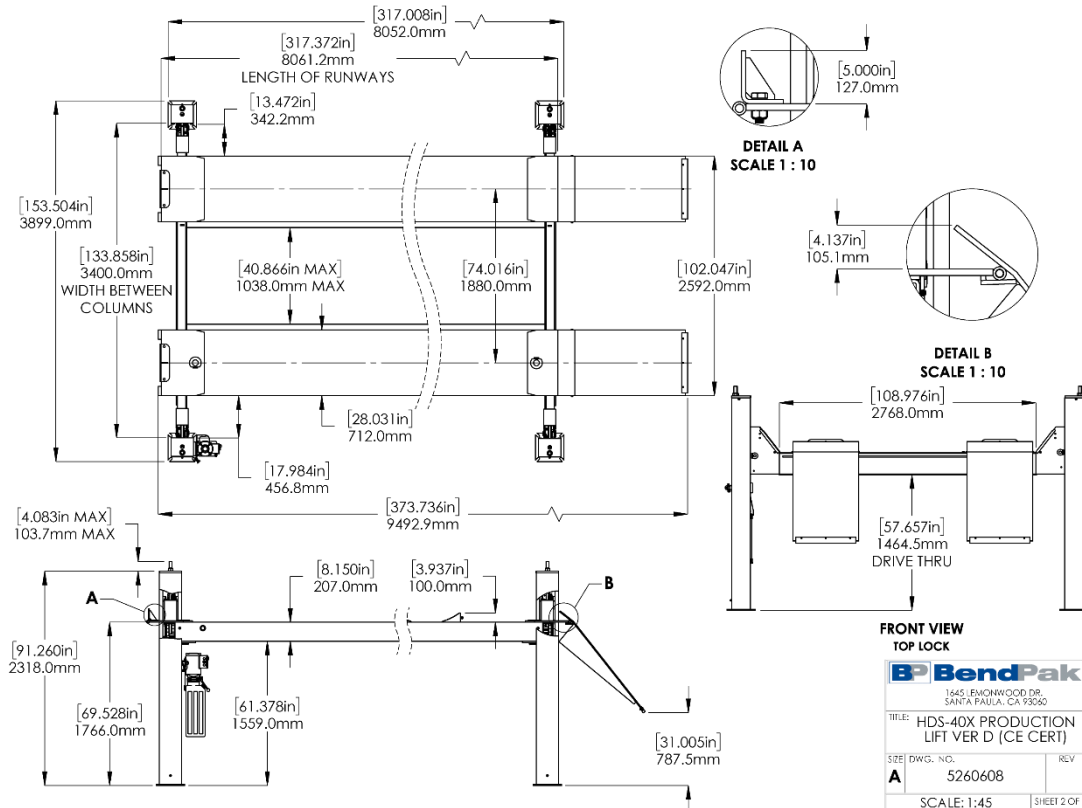

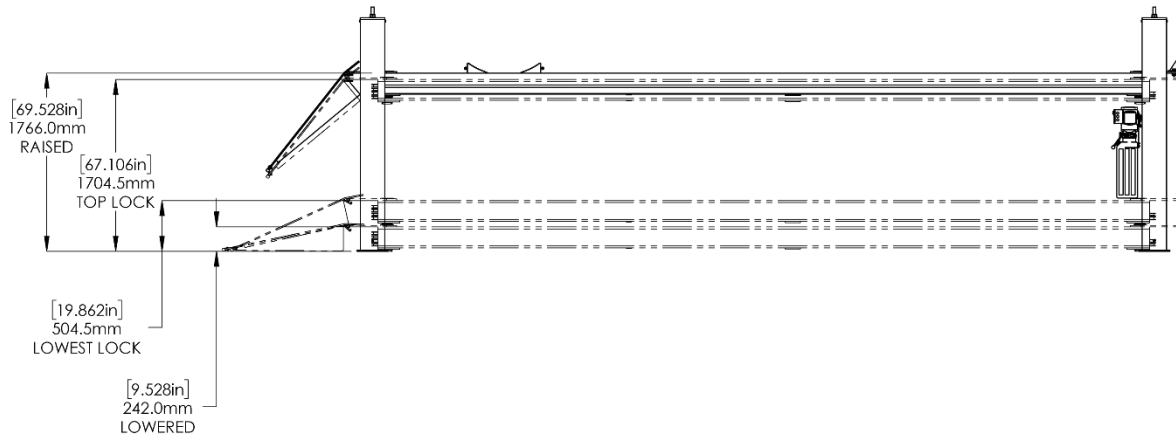

1. DIMENSIONS SHOWN ARE WITH THE LOCK LADDERS ADJUSTED ALL THE WAY UP
2. SAFETY LOCK POSITIONS: 13
3. SPACED EVERY: 100.0mm / 3.937"

BendPak
 1645 LEMONWOOD DR.
 SANTA PAULA, CA 93060

TITLE: HDS-40X PRODUCTION LIFT VER D (CE CERT)

SIZE DWG. NO. A 5260608 REV

SCALE: 1:45 SHEET 3 OF 3

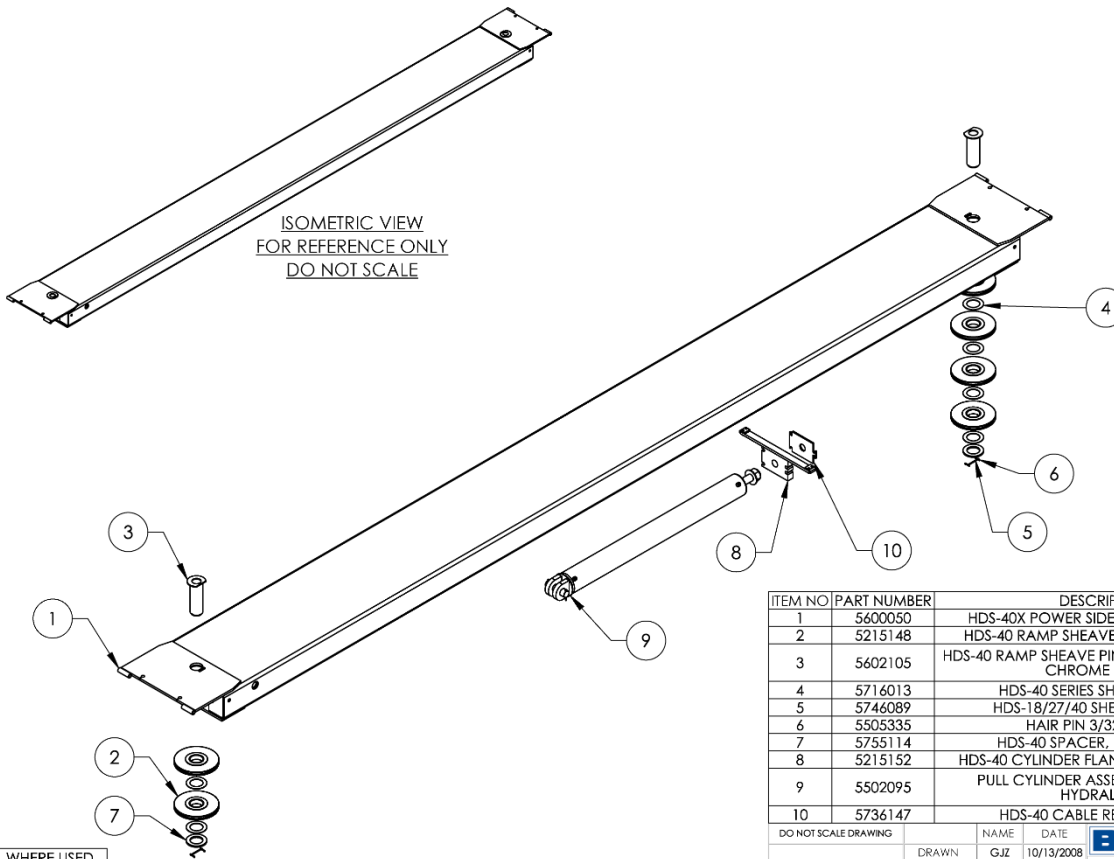

WHERE USED
 HDS-40X

NOTE: UNLESS OTHERWISE SPECIFIED

1. REFER TO MODEL FOR ADDITIONAL INFORMATION
2. SEE SHIPPING INSTRUCTIONS FOR FINAL PACKAGING
3. ASSEMBLE ITEMS AS SHOWN
4. VERIFY CYLINDER PORTS ARE CAPPED OFF WITH 3/8" NPT STEEL PLUG

NEXT ASSEMBLY
 5245092

ITEM NO	PART NUMBER	DESCRIPTION	QTY
1	5600050	HDS-40X POWER SIDE RAMP WELDMENT	1
2	5215148	HDS-40 RAMP SHEAVE ROLLER ASSEMBLY	6
3	5602105	HDS-40 RAMP SHEAVE PIN WELDMENT, Ø85mm CHROME PLATED	2
4	5716013	HDS-40 SERIES SHEAVE SPACER	6
5	5746089	HDS-18/27/40 SHEAVE SHAFT PIN	2
6	5505335	HAIR PIN 3/32" x 1 5/8"	4
7	5755114	HDS-40 SPACER, RAMP SHEAVE	2
8	5215152	HDS-40 CYLINDER FLANGE ARM ASSEMBLY	1
9	5502095	PULL CYLINDER ASSEMBLY Ø5.5 x 60 - HYDRA LOCK	1
10	5736147	HDS-40 CABLE RETAINER PLATE	1

DO NOT SCALE DRAWING

DRAWN GJZ 10/13/2008
 CHECKED

DIMENSIONS ARE IN MM



NAME DATE
 GJZ 10/13/2008

THIRD ANGLE PROJECTION

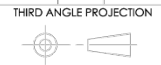

PROPRIETARY AND CONFIDENTIAL
 THE INFORMATION CONTAINED IN THIS DRAWING IS THE SOLE PROPERTY OF BENDPAK INC. ANY REPRODUCTION IN PART OR AS A WHOLE WITHOUT THE WRITTEN PERMISSION OF BENDPAK INC. IS PROHIBITED.

BendPak
 1645 LEMONWOOD DR.
 SANTA PAULA, CA 93060

TITLE: HDS-40X POWER SIDE RAMP ASSEMBLY

SIZE DWG. NO. A 5215149 REV
 SCALE: 1:35 SHEET 1 OF 2

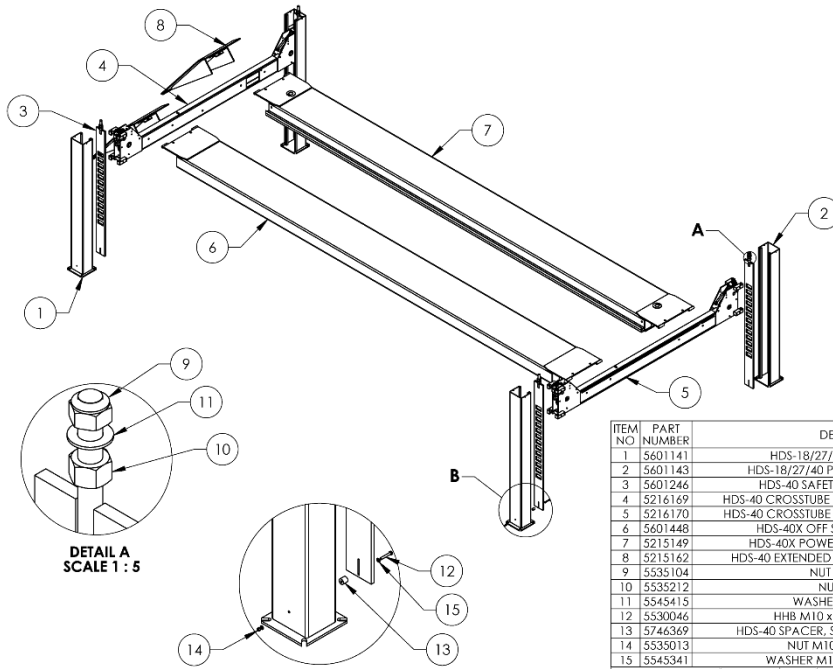

WHERE USED
HDS-40X

NOTE: UNLESS OTHERWISE SPECIFIED.

1. REFER TO MODEL FOR ADDITIONAL INFORMATION
2. SEE SHIPPING INSTRUCTIONS FOR FINAL PACKAGING
3. FASTEN NUTS AND WASHERS TO SAFETY LADDERS IN ORDER SHOWN FOR SHIPMENT

ITEM NO	PART NUMBER	DESCRIPTION	QTY
1	5601141	HDS-18/27/40 POST WELDMENT	3
2	5601143	HDS-18/27/40 POWER POST WELDMENT	1
3	5601246	HDS-40 SAFETY LADDER WELDMENT	4
4	5216169	HDS-40 CROSSTUBE ASSEMBLY, LARGE WINDOW	1
5	5216170	HDS-40 CROSSTUBE ASSEMBLY, SMALL WINDOW	1
6	5601448	HDS-40X OFF SIDE RAMP WELDMENT	1
7	5215149	HDS-40X POWER SIDE RAMP ASSEMBLY	1
8	5215162	HDS-40 EXTENDED DRIVE UP RAMP ASSEMBLY	2
9	5535104	NUT M30 x 3.5 NL	4
10	5535212	NUT M30 x 3.5	4
11	5545415	WASHER M30 x 56 FLAT	4
12	5530046	HHB M10 x 1.5 x 65 PL, CL 10.9	4
13	5746369	HDS-40 SPACER, SAFETY LADDER, 30mm LG	4
14	5535013	NUT M10 x 1.5 NL, CL10.9	4
15	5545341	WASHER M10 x Ø20 FLAT, CL10.9	8

DO NOT SCALE DRAWING

NAME: IM DATE: 12/18/2019

DRAWN: IM CHECKED: [Signature]

THIRD ANGLE PROJECTION

TITLE: HDS-40X LIFT SUPERSTRUCTURE

SIZE: A DWG. NO.: 5245092

SCALE: 1:60

PROPERTY AND CONFIDENTIAL INFORMATION OF BENDPAK INC. ALL RIGHTS RESERVED. PHOTOGRAPHY AND REPRODUCTION OF THIS DRAWING WITHOUT THE WRITTEN PERMISSION OF BENDPAK INC. IS PROHIBITED.

NEXT ASSEMBLY: 5260608

SHEET 1 OF 1

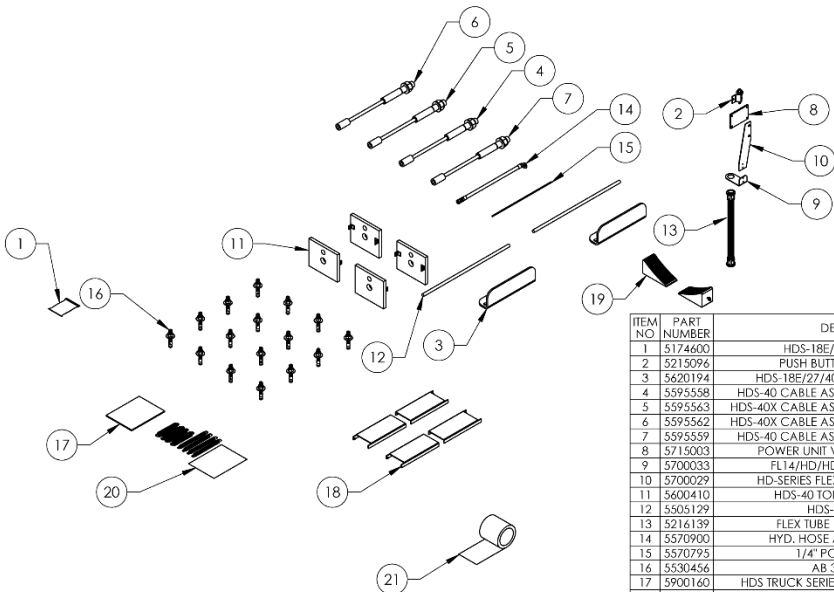

WHERE USED
HDS-40X

NOTE: UNLESS OTHERWISE SPECIFIED.

1. REFER TO MODEL FOR ADDITIONAL INFORMATION
2. SEE SHIPPING INSTRUCTIONS FOR FINAL PACKAGING
3. HOSES AND CABLES IN REPRESENTATIONAL FORM
4. (*) LENGTH FOR REFERENCE ONLY

ITEM NO	PART NUMBER	DESCRIPTION	QTY.
1	5174600	HDS-18E/27/40 PARTS BAG	1
2	5215096	PUSH BUTTON AIR ASSEMBLY	1
3	5620194	HDS-18E/27/40 TIRE STOP WELDMENT	2
4	5595558	HDS-40 CABLE ASSEMBLY Ø19 x 4102mm ST	1
5	5595563	HDS-40X CABLE ASSEMBLY Ø19 x 13742mm ST	1
6	5595562	HDS-40X CABLE ASSEMBLY Ø19 x 12027mm ST	1
7	5595559	HDS-40 CABLE ASSEMBLY Ø19 x 5836mm ST	1
8	5715003	POWER UNIT VIBRATION DAMPENER	1
9	5700033	FL14/HD/HDS FLEX TUBE ANGLE	1
10	5700029	HD-SERIES FLEX TUBE BRACKET PLATE	1
11	5600410	HDS-40 TOP PLATE WELDMENT	4
12	5505129	HDS-40 HINGE PIN	2
13	5216139	FLEX TUBE KIT, UP TO 2000mm	1
14	5570900	HYD. HOSE ASSY Ø10 x 6782mm	1
15	5570795	1/4" POLY-FLO TUBING	24000mm*
16	5530456	AB 3/4" x 4 - 3/4"	16
17	5900160	HDS TRUCK SERIES INSTALLATION MANUAL	1
18	5716633	HDS-18/27/40 CROSSTUBE COVER, PLASTIC	4
19	5716110	TRUCK RUBBER WHEEL CHOCK, SINGLE	2
20	5210242	4 POST HEAVY DUTY CE PARTS BAG	1
21	5930195	ANTI-SLIP TAPE, 6" x 24ft	1

DO NOT SCALE DRAWING

NAME: TS DATE: 10/03/2018

DRAWN: TS CHECKED: [Signature]

THIRD ANGLE PROJECTION

TITLE: HDS-40X PARTS BOX

SIZE: A DWG. NO.: 5250082

SCALE: 1:25

PROPERTY AND CONFIDENTIAL INFORMATION OF BENDPAK INC. ALL RIGHTS RESERVED. PHOTOGRAPHY AND REPRODUCTION OF THIS DRAWING WITHOUT THE WRITTEN PERMISSION OF BENDPAK INC. IS PROHIBITED.

NEXT ASSEMBLY: 5260608

SHEET 1 OF 1

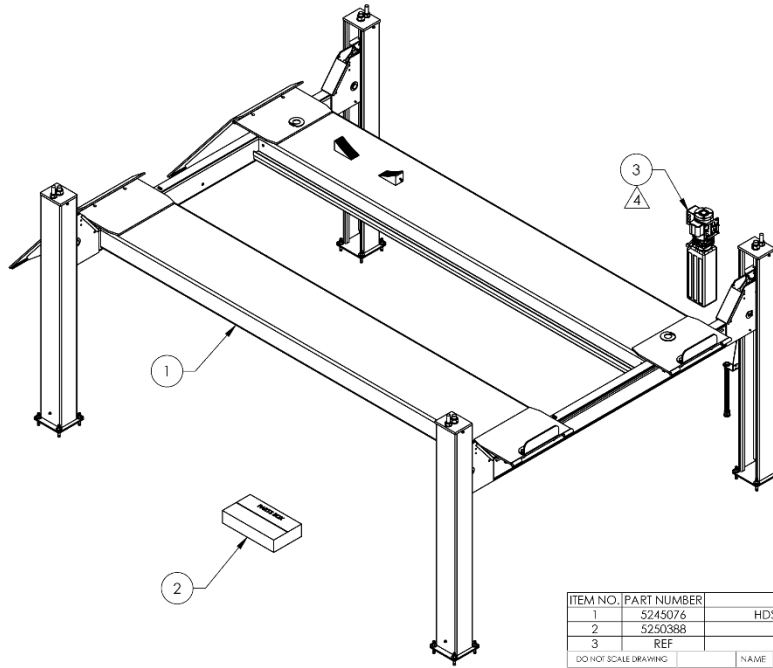

- NOTE: UNLESS OTHERWISE SPECIFIED**
1. REFER TO MODEL FOR ADDITIONAL INFORMATION
 2. SEE COLORS & GRAPHICS FOR LABEL PLACEMENT
 3. SEE SHIPPING INSTRUCTIONS FOR FINAL PACKAGING
- POWER UNIT REFERENCE ON PURCHASE ORDER

ITEM NO.	PART NUMBER	DESCRIPTION	QTY.	REV
1	5245076	HDS-40FL LIFT SUPERSTRUCTURE	1	C
2	5250388	HDS-40FL PARTS BOX	1	B
3	REF	POWER UNIT	1	-

DO NOT SCALE DRAWING		NAME	DATE	BP BendPak 3340 AGORA RD. AGORA, ILL., GA 91301
DRAWN	TM	10/19/2023		
CHECKED				
THIRD ANGLE PROJECTION		TITLE: HDS-40FL PRODUCTION LIFT VER A		
DIMENSIONS ARE IN MM		SIZE	DWG. NO.	REV
		A	5260649	
		SCALE: 1:35		SHEET 1 OF 3

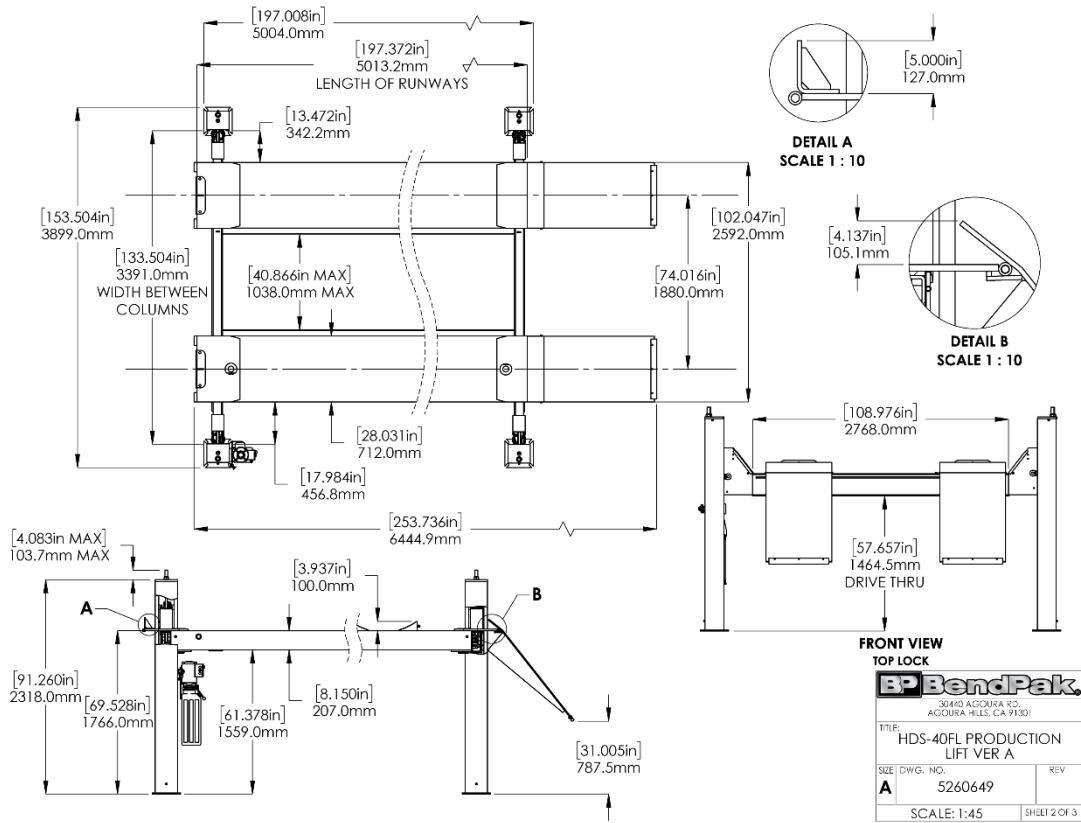

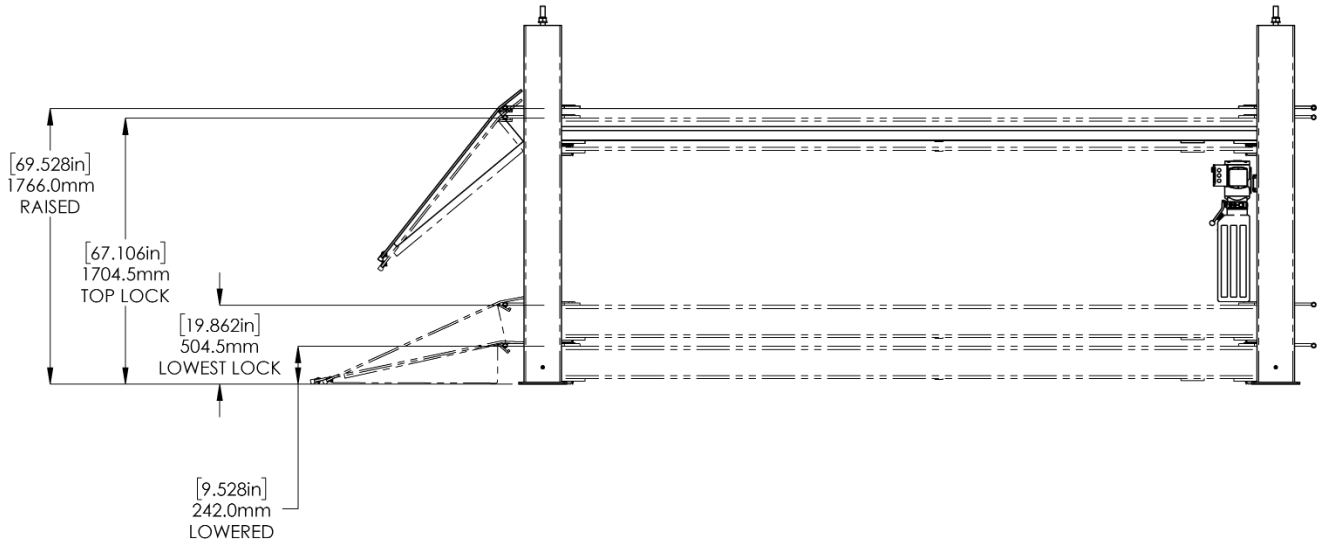

1. ALL DIMENSIONS SHOWN ARE WITH LOCK LADDER ADJUSTED ALL THE WAY UP
2. SAFETY LOCK POSITIONS: 13
3. SPACED EVERY: 100.0mm / 3.937"

BP BendPak.	
30440 AGOURA RD. AGOURA HILLS, CA 91301	
TITLE: HDS-40FL PRODUCTION LIFT VER A	
SIZE:	REV
A	5260649
SCALE: 1:33	
SHEET 3 OF 3	

Automotive Lift Institute (ALI) Store

You probably checked the [ALI's Directory of Certified Lifts](http://www.autolift.org/ali-directory-of-certified-lifts/) (www.autolift.org/ali-directory-of-certified-lifts/) before making your most recent Lift purchase, but did you know the **ALI Store** (www.autolift.org/ali-store/) offers a wide variety of professional, easy-to-use, and reasonably priced training and safety materials that will make your garage a safer place to work?

The ALI Store is your trusted source for workplace safety!



Lifting It Right Online Certificate Course. Make *sure* you and your people are lifting vehicles the right way.



ALI Lift Inspector Certification Program Registration. Become a **ALI Certified Lift Inspector**.

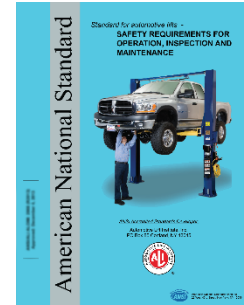

ANSI/ALI ALOIM Standard for Automotive Lifts. Safety Requirements for Operation, Inspection, and Maintenance.

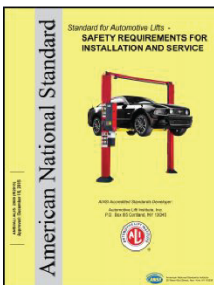

ANSI/ALI ALIS Standard. Safety Requirements for Installation and Service.



Guide to Identifying Vehicle Lifting Points for Frame-Engaging Lifts. Don't eyeball your lifting points, **know** where they are.



Lift Operator Safety Materials. Five safety documents in a single package.

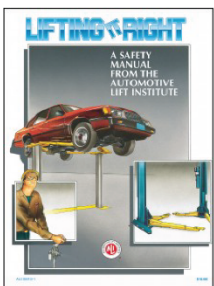

Lifting It Right. A hardcopy version of the *Lifting It Right* safety manual from the Automotive Lift Institute.



Uniform Warning Labels and Placards for 2-Posts. Labels in Mandarin, French Canadian, and Spanish are also available.



Safety Tips Card. Reminds your people of 13 key safety tips to follow daily.

Visit today and get the training and materials you need to work safely: www.autolift.org/ali-store/.