

Commercial Grade Four-Post Lift

Installation and Operation Manual

Manual P/N 5900161 — Revision H — September 2024

Models:

- HDS-14
- HDS-14X
- HDS-14XT

*Original instructions in
the English language.*

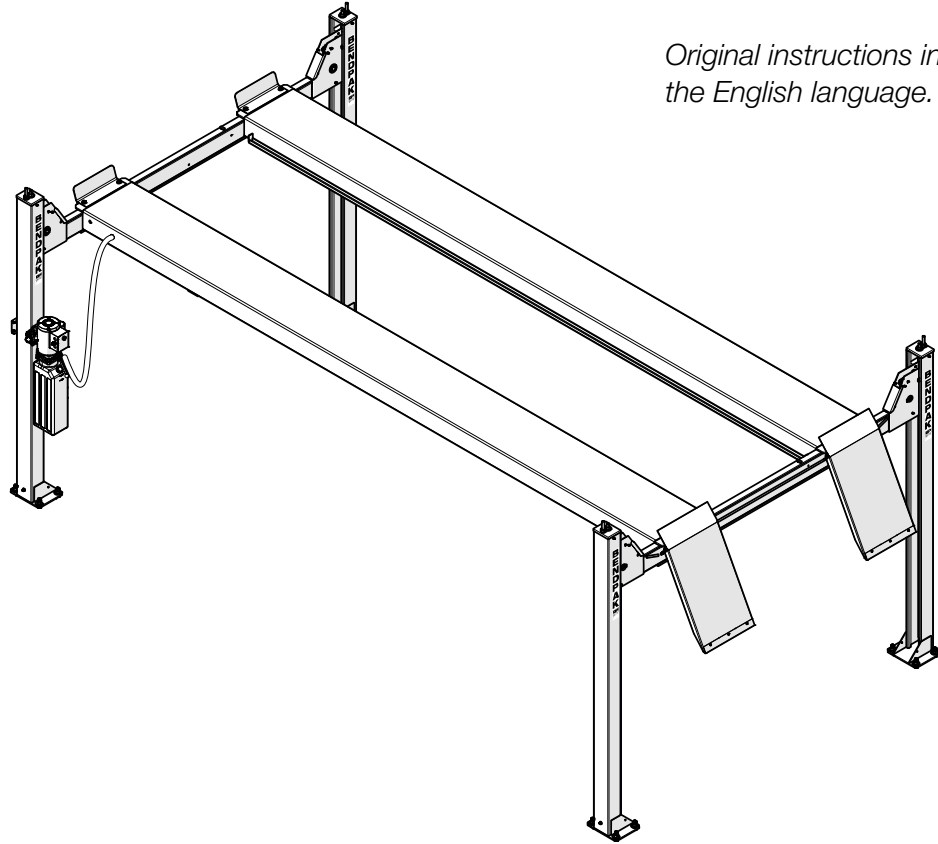

Designed and engineered by BendPak Inc. in Southern California, USA. Made in China.

 **DANGER**

IMPORTANT SAFETY INSTRUCTIONS, SAVE THESE INSTRUCTIONS! Read this manual thoroughly before installing, operating, servicing or maintaining this Lift. Failure to follow the instructions and safety precautions in this manual can result in serious injury or death. Make sure all other operators also read this manual. Keep the manual near the product for future reference. ***By proceeding with installation and operation, you agree that you fully understand the contents of this manual and assume full responsibility for product use.***

Manual. HDS-14 / HDS-14X / HDS-14XT Commercial Grade Four-Post Lift, *Installation and Operation Manual*, Manual P/N 5900161, Revision H, Released September 2024.

Copyright. Copyright © 2024 by BendPak Inc. All rights reserved. You may make copies of this document if you agree that: you will give full attribution to BendPak Inc., you will not make changes to the content, you do not gain any rights to this content, and you will not use the copies for commercial purposes.

Trademarks. BendPak and the BendPak logo are registered trademarks of BendPak Inc. All other company, product, and service names are used for identification only. All trademarks and registered trademarks mentioned in this manual are the property of their respective owners.

Limitations. Every effort has been made to make sure complete and accurate instructions are included in this manual. However, product updates, revisions, and/or changes may have occurred since this manual was published. BendPak reserves the right to change any information in this manual without incurring any obligation for equipment previously or subsequently sold. BendPak is not responsible for typographical errors in this manual. You can always find the latest version of the **manual for your product on the BendPak website**.



SCAN FOR
DIGITAL PDF

Warranty – The BendPak warranty is more than a commitment to you: it is also a commitment to the value of your new product. Contact your nearest BendPak dealer.

Safety – Your product was designed and manufactured with safety in mind. However, your safety also depends on proper training and thoughtful operation. Do not install, operate, maintain, or repair the unit without reading and understanding this manual and the labels on the unit; **do not use your Lift unless you can do so safely!**

Owner Responsibility – In order to ensure operator safety and maintain your product properly, it is the responsibility of the product owner to read and follow these instructions:

- Follow all setup, operation, and maintenance instructions.
- Make sure product setup and use conforms to all applicable local, state, and federal codes, rules, and regulations, such as state and federal OSHA regulations and electrical codes.
- Read and follow all safety instructions. Keep them readily available for operators.
- Make sure all operators are properly trained, know how to safely operate the unit, and are properly supervised.
- Do not operate the product until you are certain all parts are in place and operating correctly.
- Carefully inspect the product on a regular basis and perform all maintenance as specified.
- Service and maintain the unit only with approved replacement parts.
- Keep all instructions permanently with the product and make sure all labels are clean and visible. BendPak makes no promises, guarantees or assurances that our products meet any state, county, federal or international mandated permit, license, code, standard, certification, or any other mandate other than what is listed or shown on BendPak website(s), or any BendPak or Ranger online or published catalog. Not all BendPak lift models meet the standards as prescribed by ANSI/ALI ALCTV-(current edition) or ANSI/UL 201. Consult www.autolift.org for a complete list of lift models that meet ANSI/ALI ALCTV-(current edition) or ANSI/UL 201, or contact BendPak via contact@bendpak.com. Buyer assumes full responsibility for any state, county, federal or international mandated permit, license, code, standard, certification, or any other mandate required related to the installation and/or operation of any BendPak or Ranger product. BENDPAK will not be responsible for any charges, fines, liens, or other levies imposed on the Buyer related to any special or regional structural, seismic or any other building code and/or codes such as the Uniform Building Code (UBC), International Building Code (IBC), or any other state, county, federal or international mandated permit, license, code, standard, certification, or other mandate, law, rule, regulation or directive by any other agency, government, administrations, or corporations whether state, county, federal, or international mandated.
- **Only use the Lift if it can be used safely!**

Unit Information. Enter the Model Number, Serial Number, and the Date of Manufacture from the label on your unit. This information is required for part or warranty issues.

Model: _____

Serial: _____

Date of Manufacture: _____

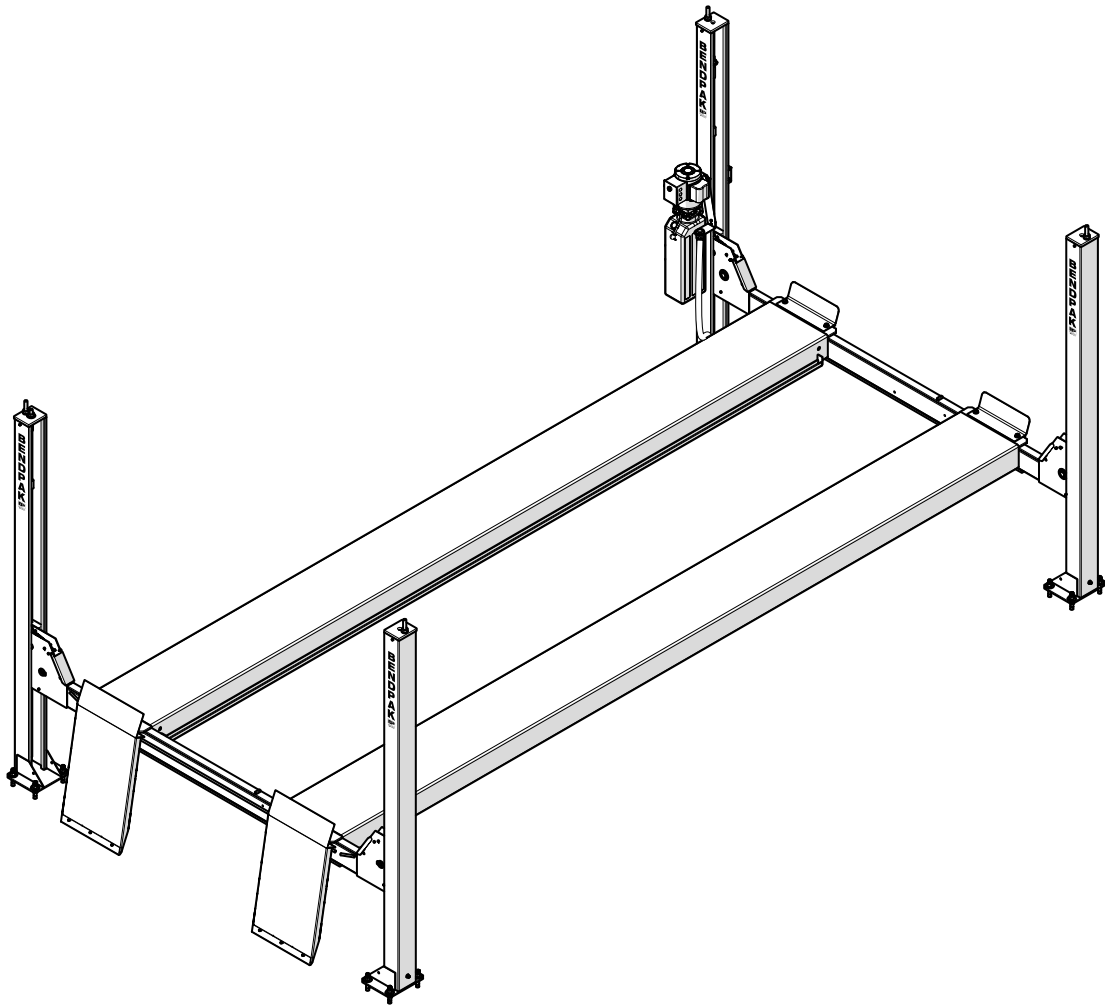

Table of Contents

Introduction	3	Maintenance	73
Shipping Information	5	Troubleshooting	80
Safety Considerations	5	Wiring Diagrams	82
Components	8	Labels	84
Specifications	10	Parts Drawings	88
FAQs	13	Certificate of Conformity	103
Installation Checklist	14	ALI Store	105
Installation	15	Maintenance Logs	106
Operation	69		

Introduction

This manual describes the following BendPak Four-Post Lifts:

- **HDS-14.** Four-Post Lift with an overall width of 131.75 in. (3,346 mm) raising Vehicles up to 14,000 lbs. (6,350 kg).
- **HDS-14X.** Has the same overall width as the HDS-14, but with an **extended length**, raising Vehicles up to 14,000 lbs. (6,350 kg).
- **HDS-14XT.** Has the same overall width as the HDS-14, but with an **extended length and height**, raising Vehicles up to 14,000 lbs. (6,350 kg).

All three models are certified by the **Automotive Lift Institute** (ALI).

This manual is mandatory reading for all users of the HDS-14 Series Lifts, including anyone who installs, uses, maintains, repairs, or wants to know more about them.

Keep this manual on or near the equipment so that anyone who uses or services it can read it. If you are having issues, refer to the **Troubleshooting** section of this manual for assistance.

⚠ DANGER Use care when installing, operating, maintaining, or repairing this equipment; failure to do so could result in property damage, product damage, injury, or in very rare cases, death. Make sure only authorized personnel operate this equipment. An authorized technician must perform all repairs. Do not make modifications to the unit; this voids the warranty and increases the chances of injury or property damage. Make sure to read and follow the instructions in this manual and on the labels on the unit.

Shipping Information

Your equipment was carefully checked before shipping. Nevertheless, you should thoroughly inspect the shipment **before** you sign to acknowledge that you received it.

When you sign a bill of lading, it tells the carrier that the items on the invoice were received in good condition. *To protect yourself, do not sign until **after** you have inspected the shipment.* If any of the items listed on the bill of lading are missing or are damaged, do not accept the shipment until the carrier makes a notation on the bill of lading that lists the missing and/or damaged goods.

If you discover missing or damaged goods **after** you receive the shipment and have signed the bill of lading, notify the carrier at once and request the carrier to make an inspection. If the carrier will not make an inspection, prepare a signed statement to the effect that you have notified the carrier (on a specific date), and that the carrier has failed to comply with your request.

It is difficult to collect for loss or damage after you have given the carrier a signed bill of lading. If this happens to you, file a claim with the carrier promptly. Support your claim with copies of the bill of lading, freight bill, invoice, and photographs, if available. ***Our willingness to assist in helping you process your claim does not make us responsible for collection of claims or replacement of lost or damaged materials.***

Safety Considerations

Read this entire manual carefully before installing or using the product. Do not install or operate the product until you are familiar with all operating instructions and warnings. Do not allow anyone else to operate it until they are familiar with all operating instructions and warnings. Keep this manual on or near the product for future reference.

 **WARNING** **California Proposition 65.** This product can expose you to chemicals including styrene and vinyl chloride which are on the list of over 900 chemicals identified by the State of California to cause cancer, birth defects or reproductive harm. Always use this product in accordance with BendPak's instructions. For more information, visit www.p65warnings.ca.gov.

Important Safety Information

Save these instructions!

1. Read all instructions.
2. Care must be taken as burns can occur from touching hot parts.
3. Do not operate equipment with a damaged cord or if the equipment has been dropped or damaged – until a qualified service person has examined it.
4. Do not let a cord hang over the edge of a table, bench, or counter, or come in contact with hot manifolds or moving fan blades.
5. If an extension cord is necessary, a cord with a current rating equal to or more than that of the equipment should be used. Cords with a current rating less than the equipment may overheat. Care should be taken to arrange the cord so that it will not be tripped over or pulled.

-
6. Always unplug the equipment from the electrical outlet when not in use. Never use the cord to pull the plug from the outlet. Grasp the plug and pull to disconnect.
 7. Let the equipment cool completely before putting away. Loop cord loosely around equipment when storing.
 8. To reduce the risk of fire, do not operate in the vicinity of open containers of flammable liquids (gasoline).
 9. Adequate ventilation should be provided when working on operating internal combustion engines.
 10. Keep hair, loose clothing, fingers, and all parts of body away from moving parts.
 11. To reduce the risk of electric shock, do not use on wet surfaces or expose to rain.
 12. Use only as described in this manual. Use only BendPak recommended attachments.
 13. ALWAYS WEAR SAFETY GLASSES. Everyday eyeglasses only have impact resistant lenses, they are not safety glasses.
 14. To reduce the risk of injury, close supervision is necessary when this product will be used around children.
 15. To reduce the risk of injury, **never** attempt to lift more than the rated capacity. Refer to loading instructions.
 16. The Lift uses electrical energy; if your organization has Lockout/Tagout policies, make sure to implement them after connecting the Lift to a power source.
 17. Refer to markings for proper load on electrical receptacles.
 18. Only operate your Lift between temperatures of +41°F to +104°F (+5°C to +40°C).
 19. The Lift should **only** be operated by authorized personnel. Keep children and untrained personnel away from the Lift.
 20. Do not make any modifications to the Lift; this voids the warranty and increases the chances of injury or property damage.
 21. Do not use the Lift while tired or under the influence of drugs, alcohol, or medication.
 22. Consider the work environment. Keep the work area clean. Cluttered work areas invite injuries. Keep areas well lit.
 23. **Always** make sure the Lift is secured on Safety Locks before attempting to work on or near a Vehicle.
 24. Make a thorough inspection of the product at least once a year. Replace any damaged or severely worn parts, decals, or warning labels. Replace worn or damaged parts with BendPak or BendPak approved parts and assemblies only.
 25. BendPak recommends referring to the ANSI/ALI ALIS Standard *Safety Requirements for Installation and Service* for more information about safely installing, using, and servicing your Lift.
 26. **HDS-14 / HDS-14X / HDS-14XT** are Four-Post Vehicle Lifts. **Use them only for their intended purpose.**
 27. You **must** always wear OSHA-APPROVED (publication 3151) personal protective equipment when installing, using, maintaining, or repairing the Lift. Leather gloves, steel-toed work boots, eye protection, back belts, and hearing protection are **mandatory**.
 28. Keep loads balanced on the Runways. Clear the area immediately if a Vehicle is in danger of falling off the Lift. Do not make any modifications to the Lift.

-
29. Modifications void the warranty and increases the chances of injury or property damage. *Do not modify any safety-related features in any way.*
30. Make sure all operators read and understand this Installation and Operation Manual. *Always keep the manual near the Lift.*
31. While handling a Hydraulic Cylinder or a Hydraulic Hose, **always** wear gloves. In rare cases, a needle-like stream of hydraulic fluid (even at low pressure) can penetrate fingers, hands, or arms; such a puncture can feel like a bite, electric shock, or a prick. While it may seem like a minor issue, any amount of Hydraulic Fluid injected into the human body is a serious issue. Anyone suffering such a puncture wound should be **immediately** taken to a hospital emergency room to determine the extent of the injury. Explain the circumstances of the injury to the attending physician, including what kind of Hydraulic Fluid was involved. Do not assume a puncture wound that could have been caused by Hydraulic Fluid is a minor issue; it could be life threatening.
32. Make an inspection of the Lift **before** using it. Check for damaged, worn, or missing parts. Do not use it if you find any of these issues. Instead, take it out of service, then contact an authorized repair facility, your dealer, or BendPak **(805) 933-9970** or email support@bendpak.com.
33. To reduce the risk of property damage, personal injury, or loss of life, **NEVER** park any vehicle on the Lift's runways without placing suitable wheel chocks behind each rear tire so that the vehicle cannot roll backward from Lift. Vehicles parked on Lift **MUST** also be placed in Park or First Gear (Manual Transmission) with the Parking Brake fully applied.

 **DANGER** Always refer to the lubricant and hydraulic fluid manufacturer's Material Safety Data Sheet (MSDS) for proper handling and disposal of chemicals.

Symbols

Following are the symbols used in this manual:

 **DANGER** Calls attention to an immediate hazard that **will** result in death or severe injury.

 **WARNING** Calls attention to a hazard or unsafe practice that **could** result in death or severe personal injury.

 **CAUTION** Calls attention to a hazard or unsafe practice that could result in minor personal injury, product damage, or property damage.

NOTICE Calls attention to a situation that, if not avoided, could result in product or property damage.



Tip

Calls attention to information that can help you use your product better.

Liability Information

BendPak Inc. assumes **no** liability for damages resulting from:

- Use of the equipment for purposes other than those described in this manual.
- Modifications to the equipment without prior, written permission from BendPak.
- Injury or death caused by modifying, disabling, overriding, or removing safety features.
- Damage to the equipment from external influences.
- Incorrect operation of the equipment.

Components

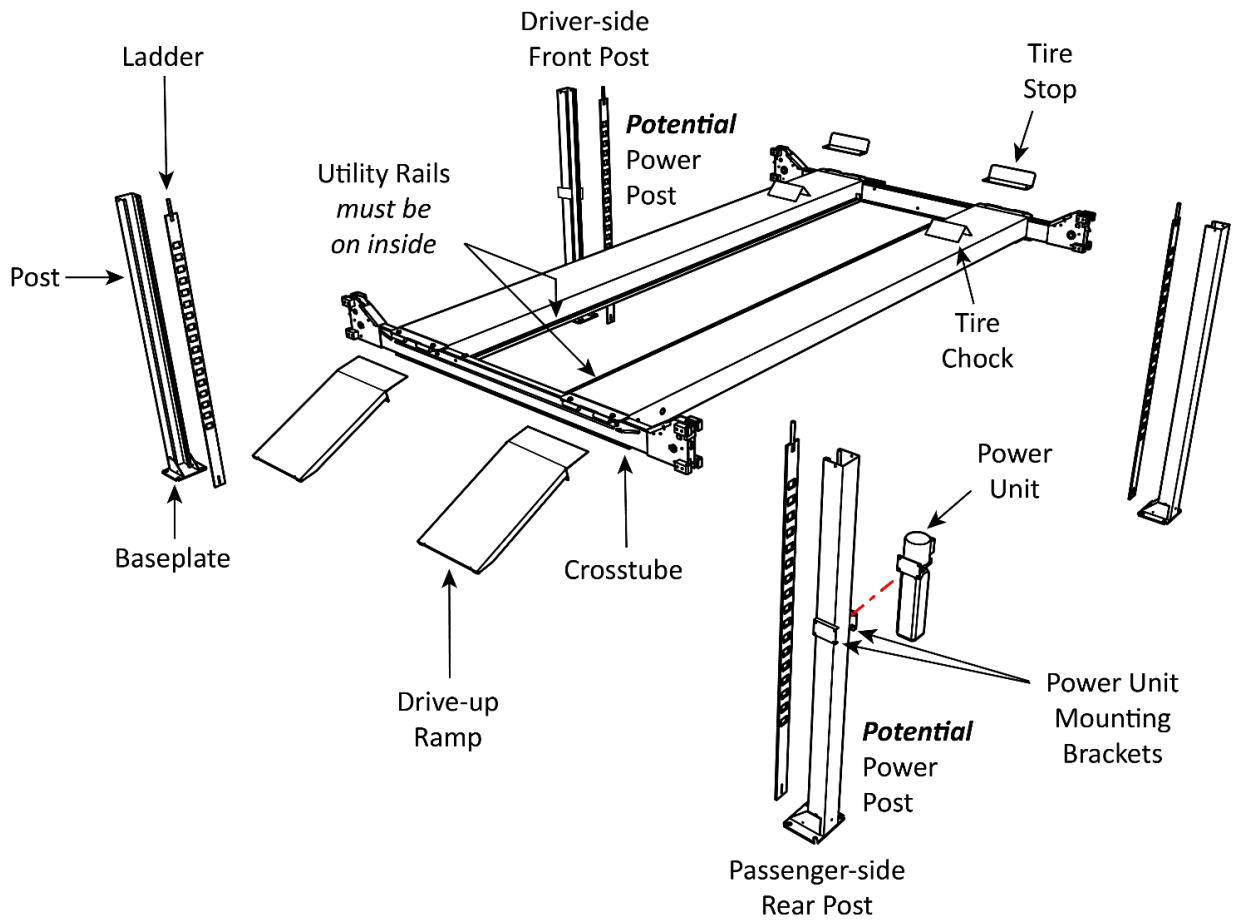

Drawing shows the two possible Power Post locations; only one Post has Mounting Brackets for the Power Unit. Not all components are shown.

The main components of the HDS-14 Series Lift include:

- **Power Post.** The Post that holds the Power Unit. **The Power Post can be in either of two locations.** The Power Post may be identified by the two Power Unit Mounting Brackets.
- **The other three Posts.** These Posts are interchangeable.
- **Power Unit.** An electric/hydraulic unit that connects to an electric power source and then provides Hydraulic Fluid to the Hydraulic Cylinder that raises and lowers the Runways.
- **Powerside Runway.** On the same side as the Power Post. The Powerside Runway has the Hydraulic Cylinder and the Lifting Cables under them. The Powerside Runway **must** go next to the Power Post.
- **Offside Runway.** The other Runway. It does not have a Hydraulic Cylinder or Lifting Cables underneath.
- **Flex Tube.** *Not shown.* A flexible, black tube that attaches to an opening on the Powerside Runway on one end and to the bottom of the Flex Tube Bracket Plate (near the Power Unit) on the other end. Used for routing the Air Line, Return Line, and Hydraulic Hose to the Power Unit.
- **Utility Rails.** Hold the optional Rolling Jacks. Utility Rails **must** go on the inside of the Lift.
- **Crosstubes.** Go at each end of the Lift. The Crosstubes are hollow; the Lifting Cables that raise and lower the Runways are routed through the Crosstubes. The Crosstubes are *not* interchangeable; each Crosstube has an opening (called a ‘Window’) that faces the inside of the Lift. **Make sure to install the Lift so that the Windows open to the inside of the Lift only.**
- **Drive-up Ramps.** One for each Runway. Use them to drive onto and off the Runways.
- **Tire Stops.** Located at the Front of the Lift, Tire Stops prevent the Vehicle’s Front Tires from going any further forward. Additionally, we strongly recommend chocking the Vehicle’s Rear Tires.
- **Safety Locks.** Once engaged, they hold the Runways in position, even if the power goes out or there is a leak in the Hydraulic Hoses. **Only leave the Runways on the ground or engaged on a Safety Lock.**
- **Pushbutton Air Valve.** Includes a Pushbutton that moves the Safety Locks away from the Safety Ladder so that they do not engage as the Runways lower. Used only to lower the Runways. Located next to the Power Unit.
- **Safety Ladders.** Part of the Safety Lock System installed at the back of each Post, somewhat resembles a Ladder.
- **Rolling Bridge Jacks.** An optional, separate product that raises wheels of the vehicle on the Lift off the Runway, making it much easier to perform brake jobs and suspension work while the vehicle is still on the Lift. Refer to the [Rolling Bridge Jack page on the BendPak website](#) for more information.

Specifications

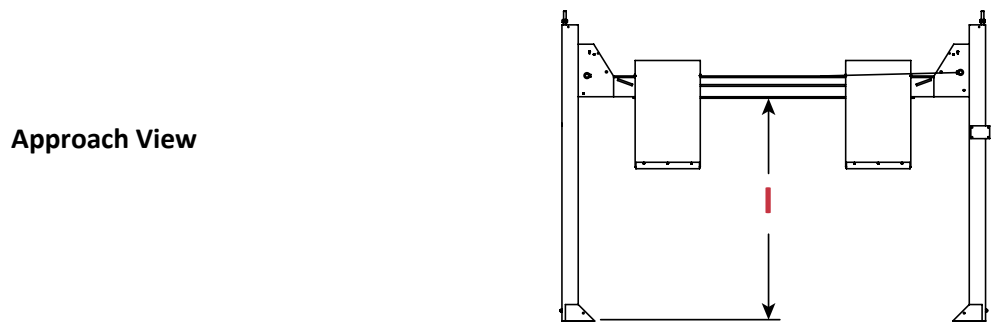
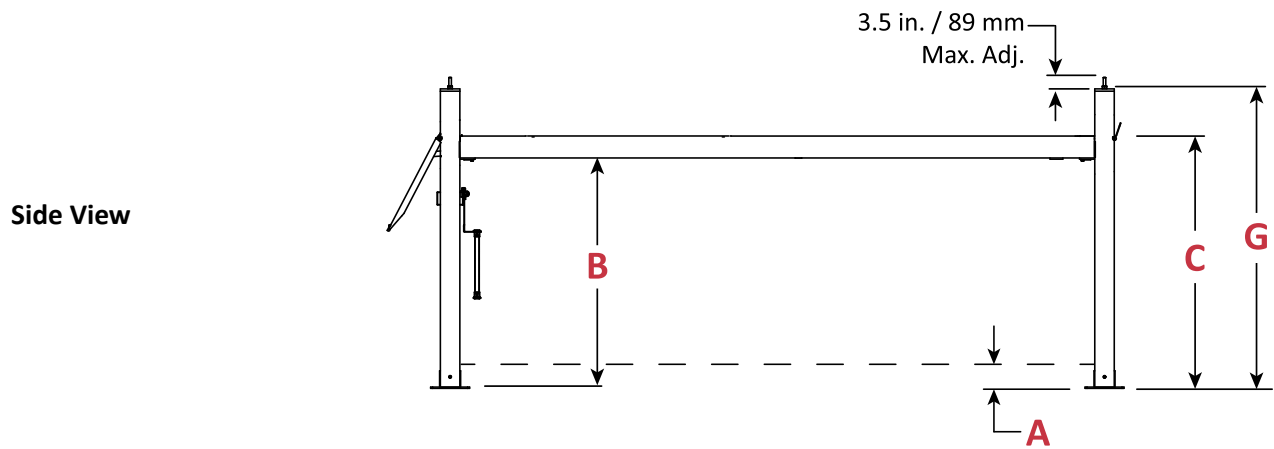
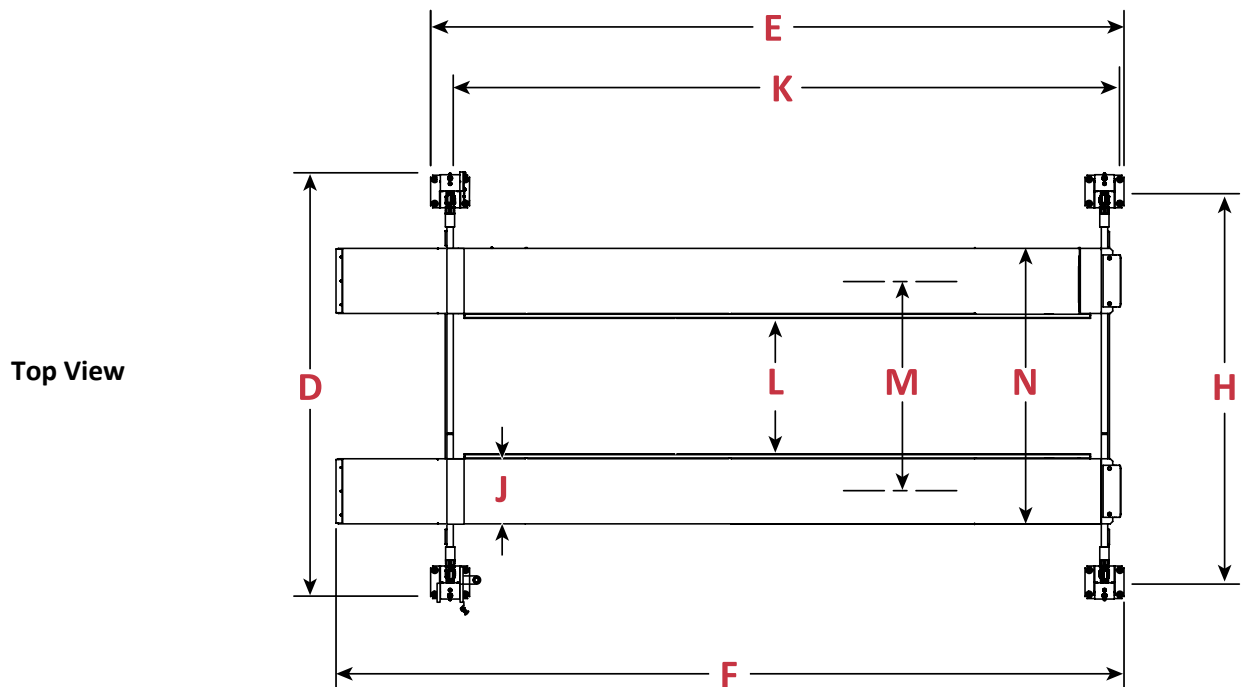

Model	HDS-14	HDS-14X	HDS-14XT
Lifting Capacity	14,000 lbs. (6,350 kg)		
Max capacity at Front Axle	7000 lbs. (3,175 kg)		
Max capacity at Rear Axle	7000 lbs. (3,175 kg)		
A Min. runway height	7.25 in. (187 mm)		7.5 in. (192 mm)
B Maximum rise	70.75 in. (1,799 mm)		82.75 in. (2,104mm)
C Maximum lifting height	77.5 in. (1,970 mm)		89.5 in. (2,275mm)
D Overall width ¹	130 in. (3,304 mm) d1 :131.25 in. (3,334 mm)		
E Outside length	213 in. (5,408 mm)	243 in. (6,170 mm)	
F Overall length	241 in. (6,131 mm)	272 in. (6,908 mm)	
G Height of post	92 in. (2,338 mm)		104 in. (2,643 mm)
H Width between posts	120 in. (3,050 mm)		
I Drive-thru clearance	68.75 in. (1,747 mm)		80.75 in. (2,052 mm)
J Runway width	20 in. (508 mm)		
K Runway length	197.5 in. (5,016 mm)	227.5 in. (5,778mm)	
L Width between runways	34.5 in. or 41.5 in. (876 or 1,058 mm)		
M Runway centerline to centerline distance	57.5 or 64.5 in. (1,460 or 1,642 mm)		
N Outside edge to outside edge of runways	77.5 or 84.5 in. (1,968 or 2,150 mm)		
Min. wheelbase @ rated capacity ²	140 in. (3,556 mm)	160 in. (4,064 mm)	
Min. wheelbase @ 75 capacity ²	120 in. (3,048 mm)	140 in. (3,556 mm)	
Min. wheelbase @ 50 capacity ²	100 in. (2,540 mm)	115 in. (2,921 mm)	
Min. wheelbase @ 25 capacity ²	80 in. (2,032 mm)	95 in. (2,413 mm)	
Safety Lock positions	13, spaced every 4 in. (101 mm)		18, spaced every 4 in. (101 mm)
Lifting time	60 seconds		90 seconds
Motor ³	220 VAC, 50/60 Hz, 1Ph 3HP 11A Typ. (Special voltages available upon request)		
Hydraulic Pressure at Max. Load	2600 psi		
Compressed Air Requirement	3 to 25 cfm at 50 to 150 psi max.		

¹ Overall Width is defined as the dimension outside to outside of the Baseplates. Use **d** measurement listed above for creating Chalk Lines. The **d1** measurement above includes the Bolt, Washer and Nut extending out near the bottom of the Posts used for securing the Safety Ladders.

² The Lift supports less weight than its rated capacity if the Vehicle's wheelbase is shorter; this is because the wheels are closer to the middle of the Runways, where there is less strength. For example, the maximum weight allowed on the Lift for a Vehicle with a wheelbase of 100 in. (2,540 mm) is 50 percent of the Lift's rated capacity (or 7,000 lbs. when the rated capacity is 14,000 lbs.).

Specifications subject to change without notice. Dimensions rounded to the nearest 0.25 in. (6.3 mm).

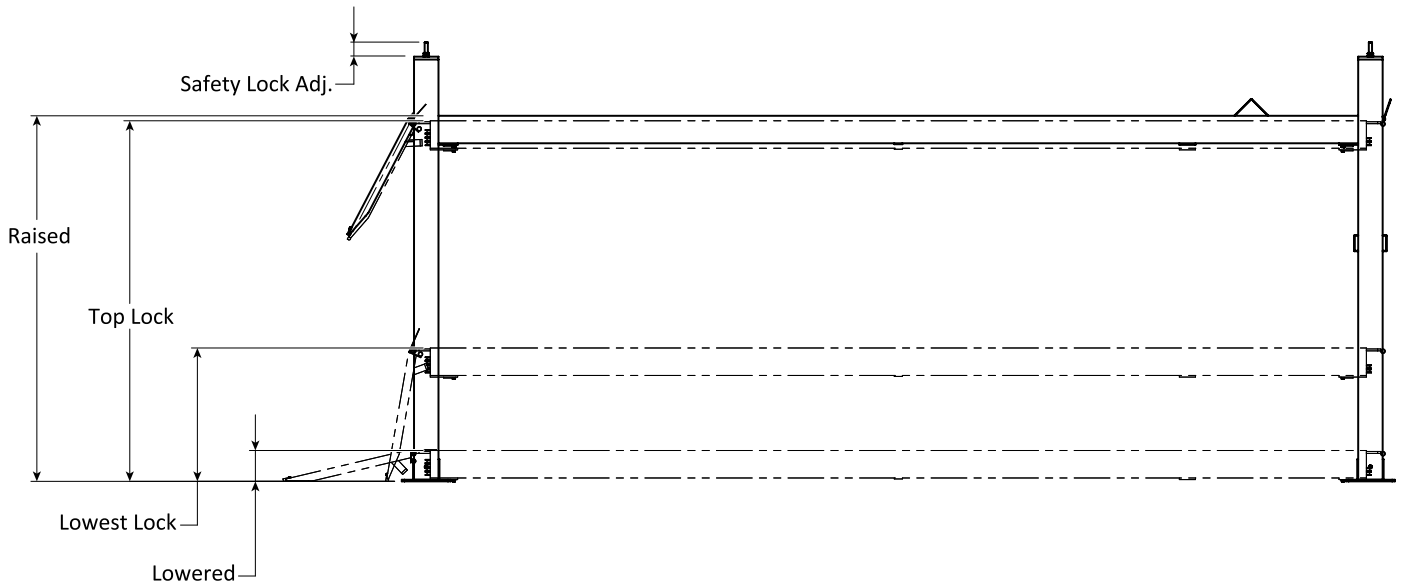

	HDS-14	HDS-14X	HDS-14XT
Raised	77.5 in. (1,970 mm)	77.5 in. (1,970 mm)	89.5 in. (2,275 mm)
Top Lock	76.25 in. (1,934 mm)	76.25 in. (1,934 mm)	88.25 in. (2,244 mm)
Lowest Lock	20.5 in. (520 mm)	20.5 in. (520 mm)	32.75 in. (830 mm)
Lowered Height	7.5 in. (192 mm)	7.5 in. (192 mm)	7.5 in. (192 mm)
Number of Safety Lock Positions	13	13	18
Spacing between Lock Positions	4 in. (101mm)		
Max. Safety Ladder Adj.	3.5 in. (89 mm)		

Note: All dimensions are measured with the Safety Ladders adjusted to their maximum height.

Frequently Asked Questions

Question: What kinds of Vehicles can I put on my Lift?

Answer: Cars, trucks, SUVs; anything that fits on the Runways, up to 14,000 lbs. (6,350 kg).

Q: Can any of the four Posts be the 'Power Post'?

A: No; the only two possible locations for the Power Post are either the *Front Driver-Side* or the *Rear Passenger-Side*.

Q: How can my Lift fit both narrow and wide Vehicles on the Runways?

A: The Offside Runway (the Runway without the cylinder) can be easily switched between the narrow and wide settings. Just unbolt the Offside Runway on both ends, slide it over to the other position, and then bolt it into position.

Q: Does the Lift have to be anchored in place?

A: Yes, BendPak **strongly** advises that the Lift be anchored. If there are plans to use the optional Rolling Bridge Jack, the Lift **must** be anchored.

Q: How high must the ceiling be?

A: It depends on the height of the Vehicles placed on the Runways and how high the Runways are raised.

Q: Does it matter if I drive my Vehicles in front first or back them in?

A: BendPak strongly recommends driving the Vehicle in front first, because that makes it easier to center the wheels on the Runways. Also, remember to put the front wheels up against the Tire Stops and always chock the rear wheels.

Q: Will the Lifting Cables really hold the Vehicles?

A: Yes. The Lift uses 12 mm thick, aircraft-quality wire rope that runs through oversized Sheaves, reducing friction and extending their life with minimal maintenance.

Q: How many Safety Locks does my Lift have?

A: The HDS-14, and HDS-14X Lifts have 15 Safety Lock Positions. The HDS-14XT has 18 Safety Lock positions.

Q: How long can I leave a Vehicle on a raised Runway?

A: As long as desired, **if the Runways are resting on their Safety Locks**. Once the Lift is engaged on a Safety Lock, gravity holds it in position, so a loss of power has no impact. Always leave the Runways either fully lowered or engaged on a Safety Lock.

Q: Can the Lift be installed outside?

A: Your Lift is approved for indoor installation and use only. **Outdoor installation is prohibited.**

Q: How many Rolling Bridge Jacks can I use on the Four Post Lift?

A: Two Rolling Jacks. **Never** place the Rolling Bridge Jack towards the middle of the Runways, they **must** be installed at the Front or Rear of the Lift. See **Usable Area** for more information.

Installation Checklist

Following are the steps required to install the HDS-14 Series Lift. Perform them in the order shown.

- 1. Review the safety rules.
- 2. Verify the necessary tools are available.
- 3. Plan for Electrical work.
- 4. Select the installation location.
- 5. Check the Clearances.
- 6. Decide the Lift Orientation.
- 7. Unload and unpack the Lift components.
- 8. Create Chalk Line Guides.
- 9. Move the Posts into position.
- 10. Install the Crosstubes.
- 11. Review About Safety Locks.
- 12. Install the Ladders and Top Caps.
- 13. Raise the Crosstubes.
- 14. Secure the Ladders.
- 15. Remove the Sheaves.
- 16. Install the Runways.
- 17. Route the Lifting Cables.
- 18. Review Working with Compression Fittings and Tubing.
- 19. Install the Air Line.
- 20. Install the Return Line.
- 21. Learn about Hydraulic Contamination.
- 22. Learn about Thread Sealants.
- 23. Install the Hydraulic Hose.
- 24. Install the Power Unit.
- 25. Install the Flex Tube Bracket Plate and Angle Plate.
- 26. Install the Flex Tube.
- 27. Install the Pushbutton Air Valve and connect the Air Lines.
- 28. Connect the Return Line.
- 29. Connect the Hydraulic Hose.
- 30. Contact the Electrician.
- 31. Connect to a power source (**Electrician required**).
- 32. Install the Power Disconnect Switch (**Electrician required**).
- 33. Install the Thermal Disconnect, if required by local electrical code (**Electrician required**).
- 34. Review About Effective Embedment.
- 35. Anchor the Posts.
- 36. Perform final leveling.
- 37. Install the Accessories.
- 38. Lubricate the Lift.
- 39. Test the Lift.
- 40. Review the final checklist.
- 41. Leave the Manual with the owner/operator.

Installation

The installation process requires multiple steps. Perform them in the order listed.

Read the entire Installation section before beginning. Do so will provide a better understanding of the process.

 **WARNING** **Only use the factory-supplied parts that came with your Lift.** If you use parts from a different source, you void your warranty and compromise the safety of everyone who installs or uses the Lift. If parts are missing, visit bendpak.com/support or call **(800) 253-2363**, then follow the prompts.

Being Safe

While installing this equipment, your safety depends on proper training and thoughtful operation.

 **WARNING** Do not install this equipment unless you have automotive Lift installation training. Always use proper lifting tools, such as a Forklift or Shop Crane, to move heavy components. Do not install this equipment without reading and understanding this manual and the safety labels on the unit.

 **WARNING** Many of the Lift components are heavy and awkward to work with. Installation should be accomplished by competent personnel ensuring all heavy components are properly rigged and balanced for lifting. Installation personnel should have knowledge, training, and experience in lifting, rigging, and securing heavy objects.

Only fully trained personnel should be involved in installing this equipment. Always pay attention. Use appropriate tools and lifting equipment. Stay clear of moving parts.

BendPak recommends referring to the current version of the ANSI/ALI ALIS Standard *Safety Requirements for Installation and Service* for more information about safely installing, using, and servicing the Lift.

 **WARNING** You **must** always wear OSHA-APPROVED (publication 3151) personal protective equipment when installing, using, maintaining, or repairing the Lift: leather gloves, steel-toed work boots, eye protection, back belts, and hearing protection are **mandatory**.

Required Tools

You may need some or all of the following tools:

- Rotary hammer drill or similar
- 3/4 in. (19 mm) carbide bit (conforming to ANSI B212.15)
- Hammer, crow bar, and two sawhorses
- Four-foot level and 12 ft. (3,657 mm) ladder
- Open-end wrench set, SAE and metric
- Socket and ratchet set, SAE and metric
- Red and White Lithium Grease
- Hex key wrench set
- Medium crescent wrench, torque wrench, pipe wrench
- Chalk line
- Medium-sized flat screwdriver and needle-nose pliers
- Tape measure 25 ft. min. (7,620 mm)
- Forklift, Shop Crane, or heavy-duty rolling dolly

Planning for Electrical Work

A licensed Electrician is required to connect the Lift to electrical power.

Notify your Electrician in advance so that they arrive prepared with appropriate wiring or cable with a Plug for connecting to the power source, a Power Disconnect Switch, and a Thermal Disconnect (if required by local electrical code).

NOTICE Wiring must be provided by the Electrician; it is not supplied with the Lift.

⚠ DANGER All wiring **must** be installed by a licensed Electrician. Verify electrical work conforms to all applicable local and federal codes, rules and regulations, such as state and federal OSHA regulations and electrical codes.

The Electrician is required to:

- **Connect the Power Unit to an electric power source.** An electric power source is required. The Power Unit comes with a pigtail for wiring to a power source. Have your Electrician remove the pigtail and wire from inside the Electrical Box on the Power Unit to a Power Cord and Plug or have them wire it directly into the electrical system at the Lift location.

Note: Installing the Power Unit and connecting the Power Unit to the power source are *separate* procedures and are completed at different times in the installation process. You do not need an Electrician to install the Power Unit, but an Electrician is **required** to connect the Power Unit to the power source.

- **Install a Power Disconnect Switch.** Ensures you can quickly and completely interrupt electrical power to the Lift in the event of an electrical circuit fault, emergency, or when equipment is undergoing service or maintenance. Put it within sight and reach of the Lift operator.
- **Installing a Thermal Disconnect Switch.** The Power Unit supplied with this Lift **does not** include thermal overload protection. Under NEC 430, UL 201, and CSA C22.2 No. 68 intermittent duty motors are **not** required to include thermal protection. Local electrical codes may vary, and other requirements may exist that the installing electrician will address, as required.

⚠ DANGER If local Electrical codes require the installation of a Thermal Disconnect, the disconnecting device and the installation **must** be provided and installed by a licensed Electrician in accordance with local electrical codes. Do not perform **any** maintenance or installation on the Lift without first verifying that main electrical power has been disconnected from the Lift and **cannot** be re-energized until all procedures are complete.

Electrical Information

⚠ DANGER All wiring **must** be performed by a licensed Electrician in accordance with national and local codes. Do not perform any maintenance until main electrical power has been disconnected from the Lift and cannot be re-energized until all procedures are complete.

Important electrical information:

- Improper electrical installation can damage the Power Unit motor, which is not covered by the warranty.
- The Lift uses electrical energy; if your organization has Lockout/Tagout policies, make sure to implement them after connecting to a power source.
- Use a separate circuit breaker for each Power Unit.
- Protect each circuit with a time delay fuse or circuit breaker:
 - For a 208 to 230 VAC, single phase circuit, use a 25 amp fuse.
 - For a 208 to 230 VAC, three phase circuit, use a 20 amp fuse.
 - For a 380 to 440 VAC, three phase circuit, use a 15 amp fuse.

Selecting a Location

When selecting the location for your Lift, consider:

- **Architectural plans.** Consult the architectural plans for your desired installation location. Make sure there are no issues between what you want to do and what the plans show.
- **Available space.** Make sure there is enough space for the Lift: front, back, sides, and above.
- **Overhead Clearance.** Check for overhead obstructions such as building supports, heaters, electrical lines, low ceilings, hanging lights, and so on. Use the maximum lifting height of your Lift model plus the height of the tallest Vehicle you plan on raising to determine how much height you will need at the Lift location.
- **Power.** You need an appropriate power source for the Power Unit.

 **DANGER** Risk of explosion: The Power Unit has internal arcing or parts that may spark and should not be exposed to flammable vapors. This Motor should **not** be located in a recessed area or below floor level.

 **DANGER** Never expose the Power Unit motor to rain or other damp environments. Damage to the motor caused by water is **not** covered by the warranty.

- **Outdoor installations.** Your Lift is approved for indoor installation and use only. **Outdoor installation is prohibited.**
- **Floor.** Only install the Lift on a flat, concrete floor; do not install on asphalt or any other surface. The surface must be level; do not install if the surface has more than three degrees of slope.

 **WARNING** Installing your Lift on a surface with more than three degrees of slope could lead to injury or even death. Only install the Lift on a level floor (defined as no more than 3/8 of an inch difference over the installation area). If your floor is not level, consider making the floor level or using a different location.

- **Shimming.** If your concrete floor is not completely level, you can use Shims under the bases of the Posts, as needed, to level the Lift. To estimate your Shim requirements, use a transit level and targets to check for flatness. Use the provided Shims as necessary.

NOTICE Do not shim a Post more than half an inch using the provided Shims and Anchor Bolts. A maximum shim of 2 in. (51 mm) is possible by ordering optional Shim Plates. Contact BendPak at **(800) 253-2363**, follow the prompts to order.

-
- **Concrete specifications.** Do not install the Lift within 6 in. (152 mm) of cracked or defective concrete. Make sure the concrete is at least 4.25 in. (108 mm) thick, 3,000 PSI, and cured for a minimum of 28 days.

⚠ CAUTION BendPak lifts are supplied with installation instructions and Concrete anchors that meet the criteria set by the current version of the American National Standard “Automotive Lifts – Safety Requirements for Construction, Testing, and Validation”, ANSI/ALI ALCTV. You are responsible for any special regional structural and/or seismic anchoring requirements specified by any other agencies and/or codes such as the Uniform Building Code (UBC) and/or International Building Code (IBC).

Be sure to check your floor for the possibility of it being a **post-tension slab**. In this case, contact the building architect **before** drilling. Use of ground penetrating radar may be required find the tensioned steel.

⚠ WARNING Cutting through a tensioned Cable can result in injury or death. Do not drill into a post-tension slab unless the building architect confirms the area is free of tensioned steel or you have located it using ground penetrating radar. **If colored sheath comes up during drilling, stop drilling immediately.**

- **Multi-Lift installations.** In a Multi-Lift layout, there must be a *minimum* spacing of 5 in. (127 mm) from the edge of the Baseplates to the edge of the Baseplate on the next Lift.

⚠ WARNING Installing a Lift closer than 5 in. (127 mm) from the next Lift compromises the holding strength of the Anchor Bolts, putting anyone near the Lifts in danger.

Checking Clearances

Clearance around and above the Lift is **required for safety**. Refer to the figure below.

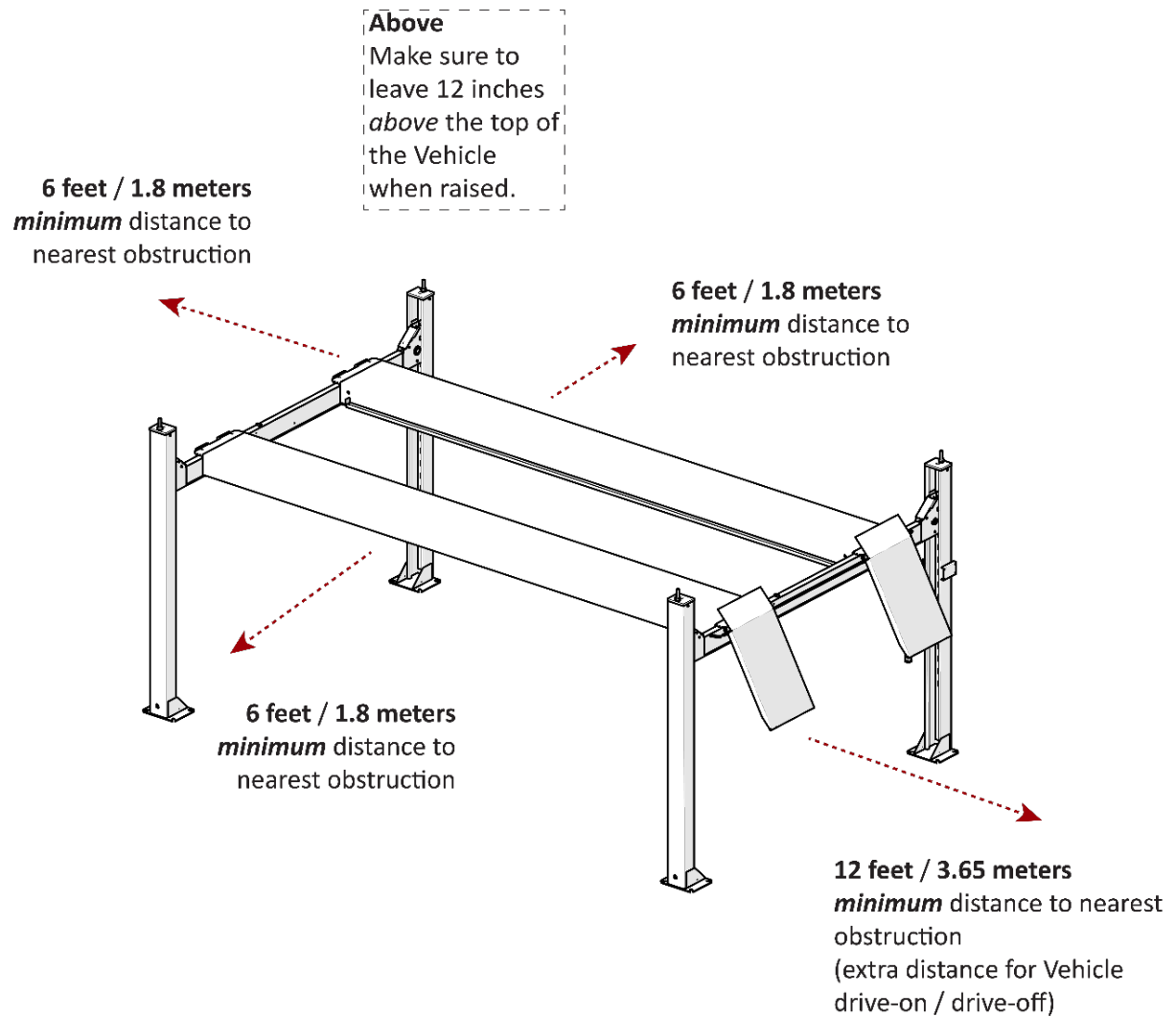

Usable Area

The strength of the Runways is reduced in the middle. Do **not** place the Wheels of a Vehicle you are raising in this area. The same restriction applies to Rolling Jacks and Bottle-Jack Trays; they must **not** be used in this middle section of the Runways.

⚠ CAUTION Do not load Vehicles so that the Wheels are in the middle of the Runways or use Rolling Jacks or Bottle-Jack Trays in that area; it could permanently damage the Runways. Damage caused by this **unsupported** use of the Lift is **not** covered by the Warranty.

This will not impact the use of the Lift in most cases, as the wheelbase length of most Vehicles put the Wheels in the Usable Areas.

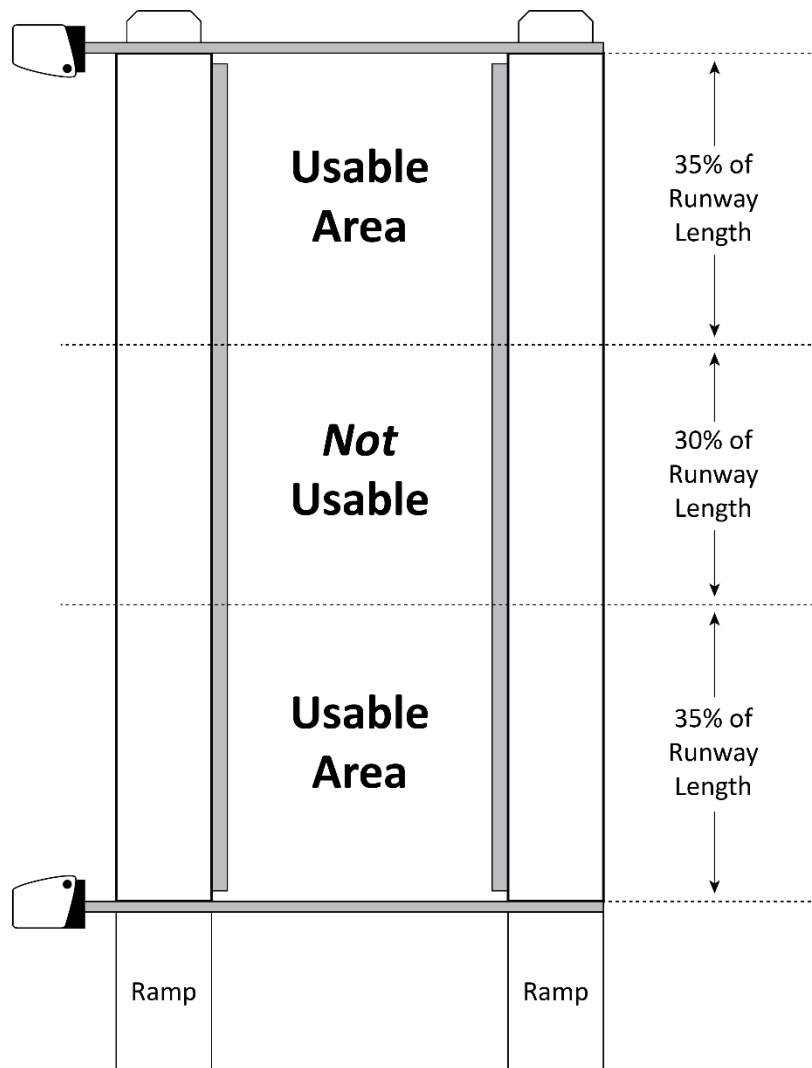

Top view. Drawing not to scale. Not all components shown.

For more information about the BendPak Rolling Jacks, visit our [Rolling Jacks website page](#).

Deciding the Lift Orientation

Before proceeding, decide how the Lift is to be oriented. This decision affects where the Power Post will be placed and the positioning of the Runways and their approach, which are **not** interchangeable.

The Powerside Runway **must** be installed next to the Power Post. You can choose to position the Power Post at either the **Front Driver-Side** or the **Rear Passenger-Side**. The Drive-up Ramps are not affected by the Power Post location.

Many figures in this manual display the Power Post at the **Rear Passenger-Side**. In many cases, the main factor is the location of the power source; many customers prefer to place their Power Post (which holds the Power Unit) near the power source. If power access is not an issue, choose the option that best suits the installation.

Important: Installers, the Lift orientation must be decided before placing the Posts into position.

Power Post Location – Front Driver-side

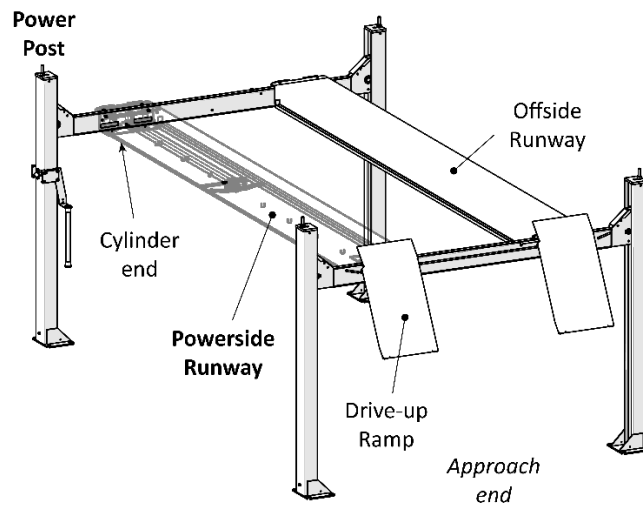

Power Post Location – Rear Passenger-side

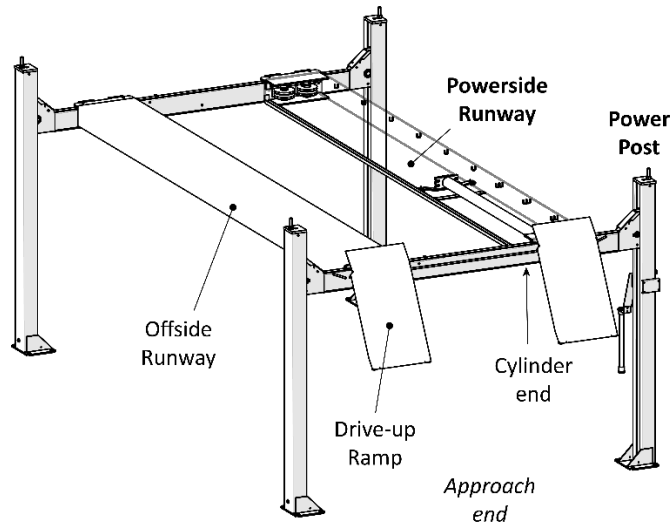

Creating Chalk Line Guides

Create the Chalk Line Guides so that the outside edges of all four Posts fit into the four corners created by the Chalk Line Guides.

See **Specifications** to determine the **Overall Width** and **Outside Length** values for the Lift.

Note: Do **not** use the **Overall Length** value; this includes the Ramps, which are not taken into consideration for creating Chalk Line Guides.

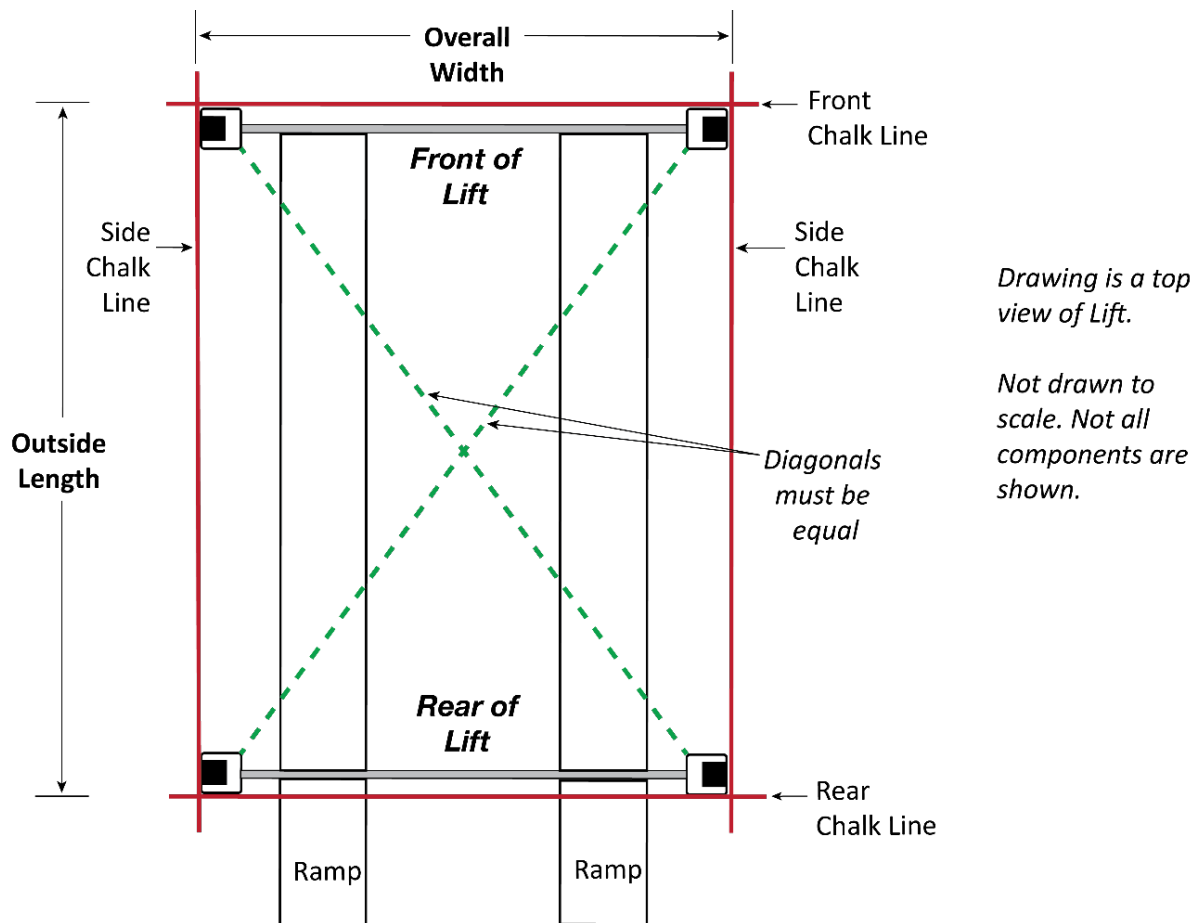

To create Chalk Line Guides:

1. Create the Front and Rear Chalk Lines; make the Front and Rear Chalk Line *longer* than the **Overall Width** setting.

The Front and Rear Chalk Lines **must** also be parallel to each other; *measure to verify that they are parallel.*

2. Create the two Side Chalk Lines at 90° angles to the Front Chalk Line and parallel to each other; make the Side Chalk Lines longer than the **Outside Length** setting

3. Before moving the Posts into position, measure **diagonally** to make sure the two diagonal measurements are the same. This ensures your layout is correct.

Do not forget to check the diagonals.

4. When you move the Posts into position, put the corners of the Base Plates inside the corners created by the four Chalk Lines.

Unloading and Unpacking

The Lift includes a number of heavy components, the closer you unload them to the installation site, the easier the installation task will be.

⚠ CAUTION Some Lift components are very heavy; if handled incorrectly, they can damage materials like tile, sandstone, and brick. Try to handle the Lift components twice: once when delivered and once when moved into position. A Forklift or Shop Crane will be required to move them into position. Use care when moving these components.

⚠ WARNING The Posts and Runways are delivered with stabilizing structures on each end. Be very careful when removing these stabilizing structures; the Posts and Runways can shift or even fall. If they fall on a person, they could cause serious injury.



Moving the Posts into Position

Use a Forklift or Shop Crane to move the Posts, one at a time, to the inside corners of the Chalk Line Guides.

Important: Position the Power Post at your chosen location. Remember, the Power Post can only go in two possible locations: the **Front Driver-Side** or the **Rear Passenger-Side**. The other three Posts can go at any of the remaining Post locations. Refer to **Deciding the Lift Orientation** for more information.

⚠ DANGER The Posts are extremely heavy; use caution when handling them. If they shift position or fall, they could cause serious injury. Only allow trained personnel move the Post and use appropriate lifting devices, such as a Forklift or Shop Crane.

Do not stand up the Posts yet; some of the following procedures are easier to complete if the Posts are laying on the ground.

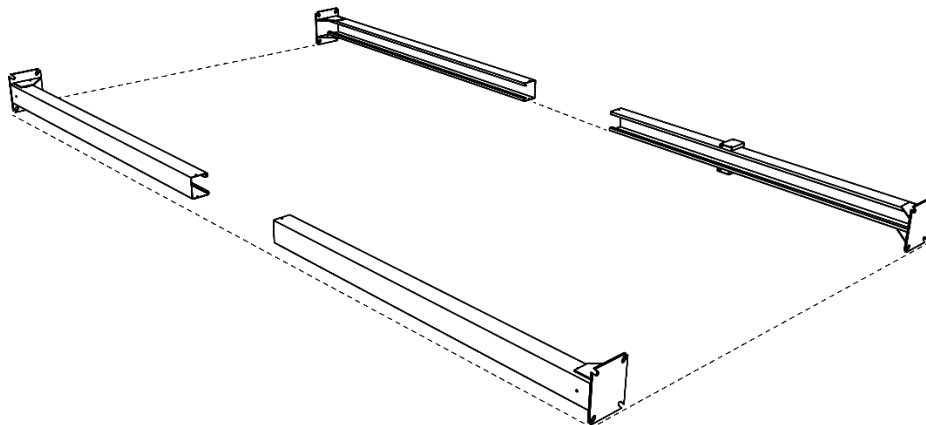

To move the Posts into position:

1. Using a proper lifting device, move the Posts, one at a time, to the inside corners of the Chalk Line Guides.
2. Do not anchor the Posts at this point.

Installing the Crosstubes

The HDS-14 Series Lift has two Crosstubes:

- **Crosstube with a Large Window:** Installed on the end of the Lift *opposite* of the Power Post, with the Large Window facing to the inside of the Lift.
- **Crosstube with a Small Window:** Installed adjacent to the Power Post, with the Small Window facing to the inside of Lift.

Important: It is possible to install the Crosstubes **incorrectly** in several different ways. Take your time now and get it right the first time.

The following drawing shows the correct locations for the Crosstubes.

Power Post Location:
Rear Passenger-side

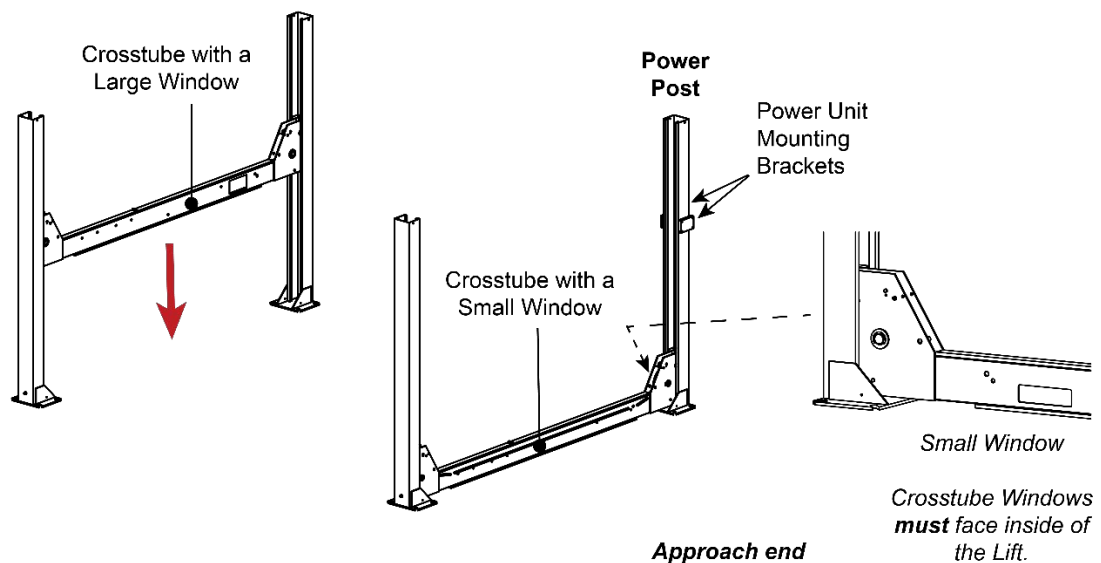

To install the Crosstubes:

1. Orient the Crosstubes in their required locations.
2. Put the black Slide Blocks (5716005) into place on the outside ends of each Gusset, four Slide Blocks per each Crosstube Gusset.

Align the holes in the Slide Blocks with the rods on the side of the Gusset, then press the Slide Blocks in. Make sure the Slide Blocks are oriented so that they create a Slot when pushed in.

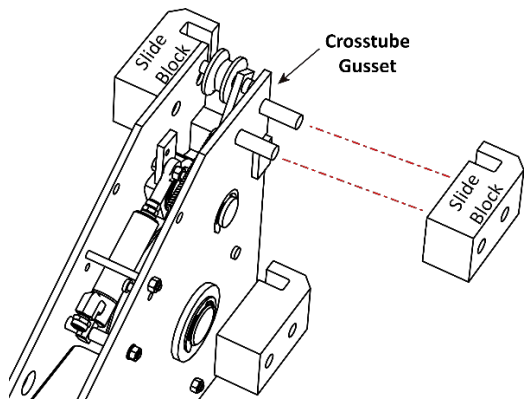

Top View. Drawing shows how to properly install two Slide Blocks onto the Crosstube Gusset.

Not all components are shown.

The four Slide Blocks on a Gusset create two slots. There is one Slot at the top of the Gusset and a second Slot at the bottom; the Ladder **must** go through **both** Slots in the Gusset.

⚠ WARNING If the Slide Blocks are not correctly installed, then the Slots for the Ladder are not created. In such a case, the Safety Locks will not work correctly, which endangers everyone who uses the Lift. Make sure to correctly install the Slide Blocks.

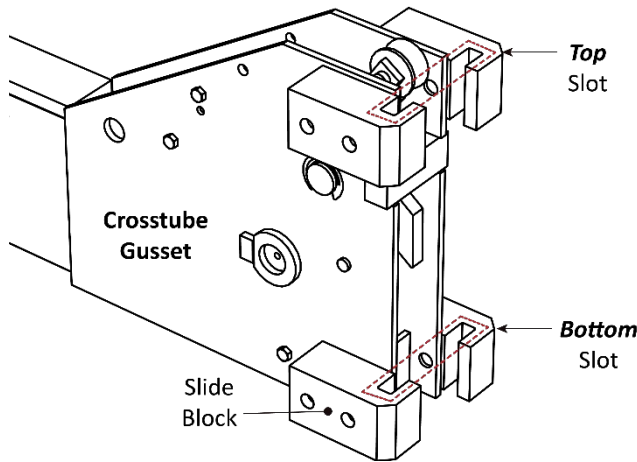

Front View. Drawing shows the Top and Bottom Slots created by the Slide Blocks.

Not all components are shown.

3. Put the Crosstubes into place by doing either of the following:

- Lean over the two Posts at one end of the Lift (some people put them on sawhorses, some people lay them on the ground), slide the Crosstubes into place, then carefully stand up the Posts; make sure to put them back in their correct locations inside the Chalk Line guides.
- Carefully stand up the Posts, use a Forklift or Shop Crane to raise the Crosstube above the top of the two Posts that it goes between, and then slide the Crosstube down to the bottom.

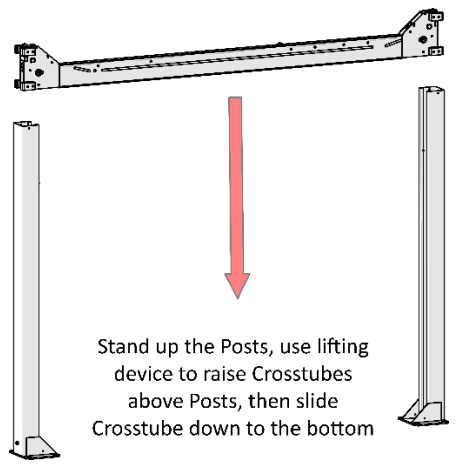
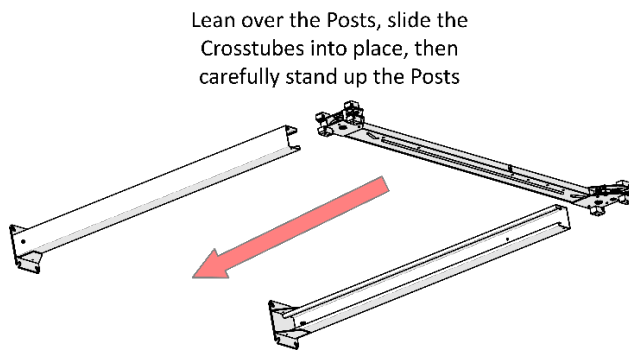

⚠ WARNING Use care when installing the Crosstubes, as the Posts are not anchored in place at this point. Dropping or knocking over the Posts may cause permanent damage equipment damage or serious personal injury. The Crosstubes and Posts are heavy; do not lift without proper assistance.

4. Perform Steps 2 and 3 for the other Crosstube.

About Safety Locks

Once engaged, Safety Locks hold the Runways in place, even if the power goes out or the Hydraulic Hoses break or leak. The Safety Locks are spaced every 4 in. (100 mm). Each Post has its own Safety Ladder and set of Safety Locks.

Important: Simply raising the Runways does **not** engage them on the Safety Locks. You must back the Runways down onto the Safety Locks to engage them.

⚠ WARNING Safety Locks are dependent on correct installation of the 'Safety Ladders'. Pay careful attention when installing the Ladders, thus ensuring correct operation of the Safety Locks.

The Ladders, one per Post, are steel pieces with holes spaced every 4 in. (100 mm). As you raise the Runways, the Safety Locks snap into the openings in the Ladder. When you move the Runways back down a little after passing a Safety Lock, the Safety Lock engages. Once they are engaged, Safety Locks remain engaged until you are ready to lower the Runways.

⚠ WARNING Always leave the Runways either fully lowered or engaged on their Safety Locks. When you engage the Safety Locks at a desired height, verify that all four Safety Locks (one per Post) are properly engaged.

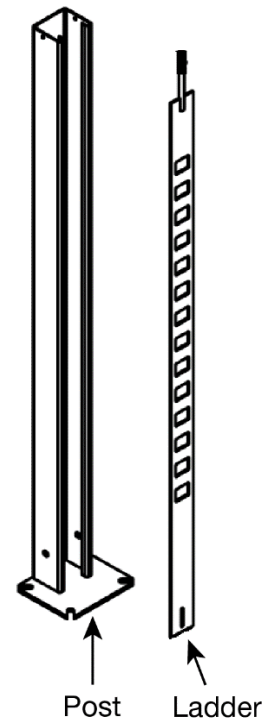

To lower the Runways, *raise* them a few inches (to move them off the Safety Ladder), then **press and hold down** the pushbutton on the Pushbutton Air Valve. While you hold down the pushbutton, the Safety Locks are pulled away from the Ladders; in this position, they cannot engage, which allows the Runways to be lowered.

Out of an abundance of caution, your Lift has a second, independent Safety Lock system called a Slack Safety.

- **Safety Locks:** The primary system to hold up the Runways on the Lift are the Safety Locks. When you move the Runways up, you can hear clicks as the Safety Locks snap into the openings in the Safety Ladders. When you want to keep the Runways at a certain height, move the Runways slightly above the height, then lower the Safety Locks down in to the openings in the Safety Ladders to engage them.
- **Slack Safety:** The Slack Safeties are next to the Safety Locks on the ends of the Crosstube Gussets. They are different from the Safety Locks in that when the Cables are taut (during normal operation), they hold the Slack Safeties away from the Safety Ladder so that the Slack Safeties cannot engage. However, if a Cable were to break (which rarely happens), the Slack Safety for the broken Cable immediately engages, preventing the Runways from falling.

The Slack Safety Locks are engaged during installation when you raise the Crosstubes (see **Raising the Crosstubes**). Make sure to disengage them immediately after raising the Crosstubes.

Installing the Safety Ladders and Top Cap

Each Post has a Safety Ladder; each is installed on the inside back of a Post. Ladders are secured at the top and the bottom.

Make sure to install each Ladder through **both slots** formed by the Slide Blocks on each Crosstube Gusset.

NOTICE: It is much easier to secure the bottom of the Ladders once the Crosstubes have been raised, so that portion of installing the Ladders is described in **Securing the Ladders**.

⚠ WARNING Make sure to install the Ladders correctly. If they are not installed correctly, the Safety Locks on the Lift may not hold the weight of a Vehicle, putting anyone under the Lift in danger. The Ladders must never rest on the base of the Post or damage to the Lift may occur.

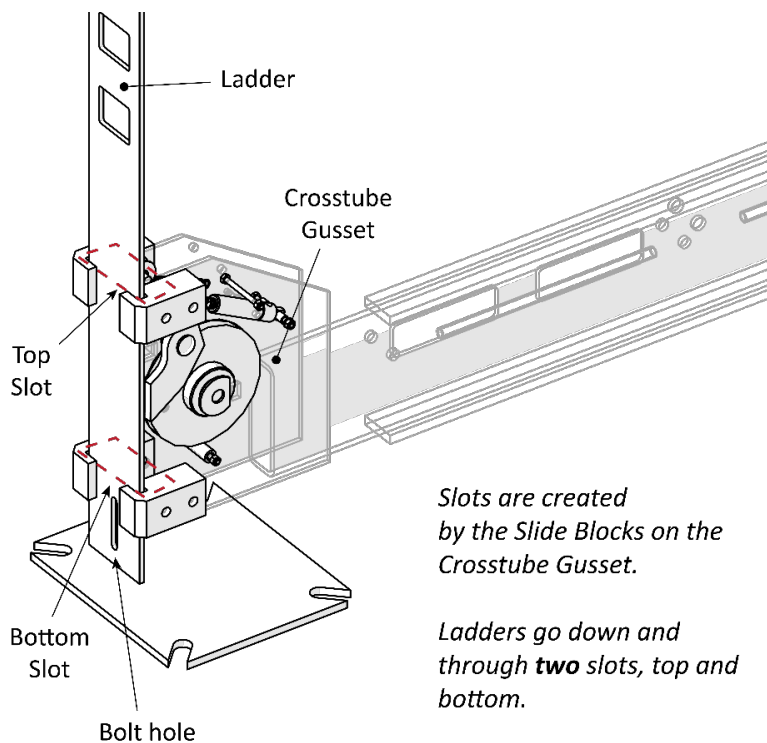

Figure to the left displays the Safety Ladders route through both Slots created by the Slide Blocks.

Not all components shown. Post not shown for clarity.

Slots are created by the Slide Blocks on the Crosstube Gusset.

*Ladders go down and through **two** slots, top and bottom.*

Post not shown in graphic.

To install the Safety Ladders and the Top Caps:

1. Retrieve a Safety Ladder and slide it down the back of the Post, with the Bolt Hole end at the bottom, as shown in the graphic above.

Verify the Safety Ladder is routed through both Slots on each Gusset.

⚠ WARNING It is easy to see the top Slot created by the Slide Blocks. It is difficult to see the bottom Slot, but it is **required** that the Ladder be routed through **both** Slots.

2. Install the remaining three Ladders in the same manner.

3. **Moving to the top of the Ladders**, put the M20 Nut on the Threaded Bolt at the top; move the M20 Nut down half an inch below the top of the Post.

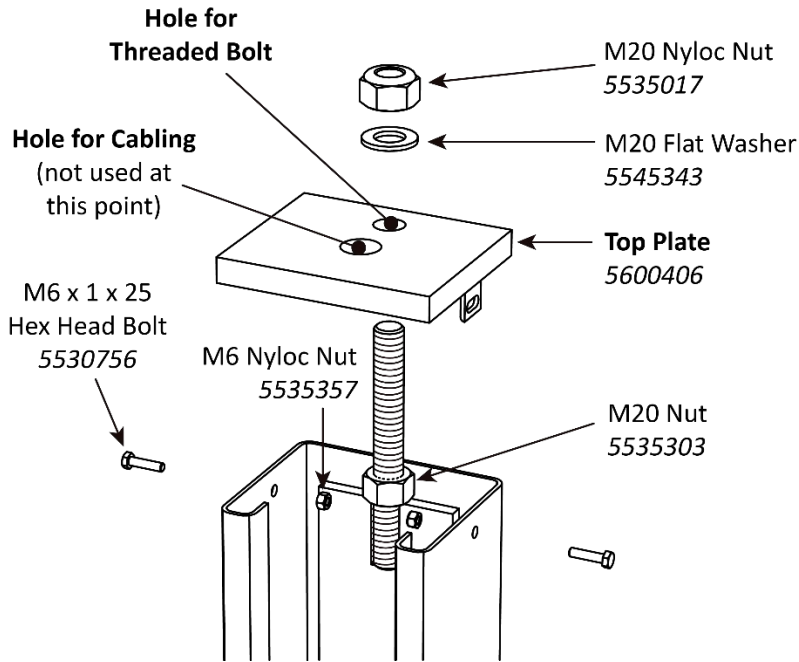

Drawing shows connections to make to the Top Cap, near the top of the Posts.

Not all components shown.

4. Put the Top Caps in place and secure the sides with two M6 Hex Bolts (5530756).
5. Attach an M20 Nyloc Nut on each Safety Ladder until **1 in. (25 mm)** of thread is above the top of the Top Nut.

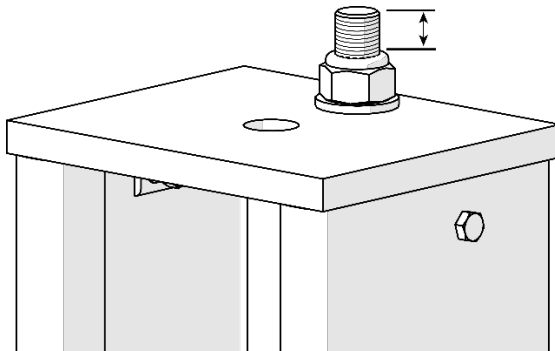

Figure to the Left details the threads exiting above the Top Nut. Adjust as required.

Not all components shown.

Important: Do not securely tighten the Top Nut at the top of the Top Cap at this point; they can be securely tightened after the final leveling to the Lift.

6. Install the remaining Top Caps in the same manner.

Raising the Crosstubes

Manually raise the Crosstubes, which will ease the rest of the installation tasks. The Crosstubes need to be raised the same height, and to the same Safety Lock window on all four posts.

⚠ WARNING Never walk or work under the lift until all four safety locks are securely engaged.

⚠ WARNING Use care when raising the Crosstubes, as the Posts are not anchored in place at this point. Dropping or knocking over the Posts may cause permanent equipment damage or serious personal injury. The Crosstubes and Posts are heavy; do not lift without assistance. BendPak strongly recommends having at least two people work together to raise the Crosstubes.

To raise the Crosstubes:

1. Use a Forklift or Shop Crane to carefully raise each Crosstube. Raise the Crosstubes at least two feet off the ground, to provide enough room to work under it, and making it easier to route the Lifting Cables and Lines.

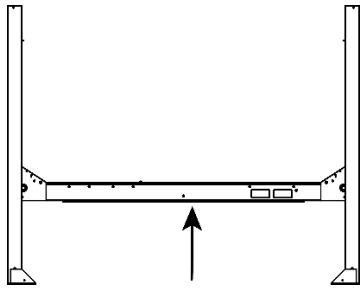

Important: *The Slack Safeties cannot be engaged as you continue with the installation.* Because the Cables are not in place yet, the Slack Safeties are going to engage when you manually raise the Crosstubes. You need to disengage them after you have raised the Crosstubes. The Primary Safeties are not impacted; they will engage normally when you manually raise each Crosstube.

2. To disengage the Slack Safeties after raising a Crosstube: raise and hold one end of a Crosstube so the Primary and Slack Safety Locks are disengaged, push and hold the Sheave in towards the Ladder and the back of the Post (this moves the Slack Safety Lock so it cannot to engage), lower the end of the Crosstube, then release the Sheave.

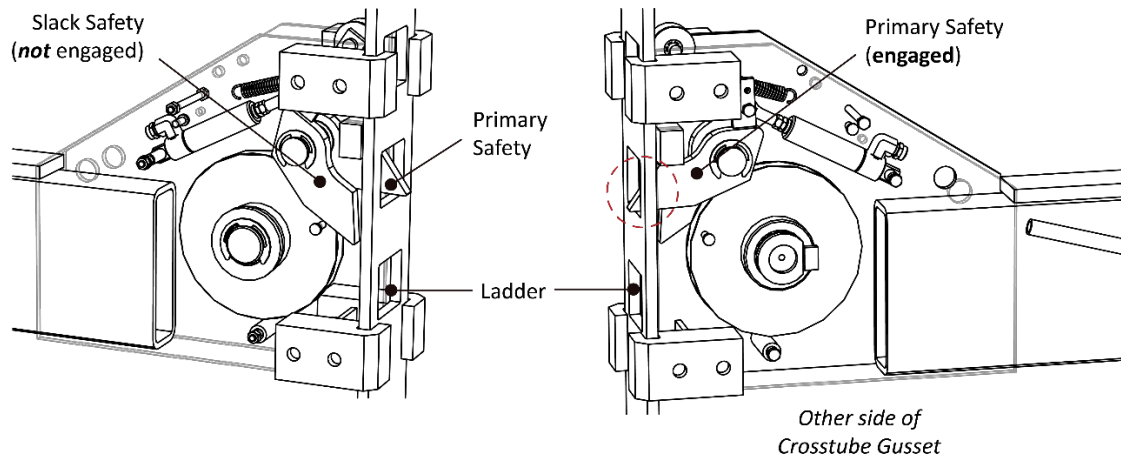

3. Disengage the other three Slack Safety Locks as done in Step 2.

- Once both Crosstubes are in position, **all four Primary Safeties are engaged**, and all four Slack Safeties have been **disengaged**, continue with the installation.

Securing the Ladders

The following procedure assumes that the Safety Ladders are in place and secured at the top. If this is **not** the case, return to **Installing the Ladders and Top Cap**.

To secure the Ladders:

- Locate the required 4 Hex Head Bolts, 8 Flat Washers, 4 Safety Spacers, and 4 Nyloc Nuts.
- Secure the bottom of the Ladders as shown in the drawing below, making sure to orient the Spacer between the Ladder and the back of the Post.

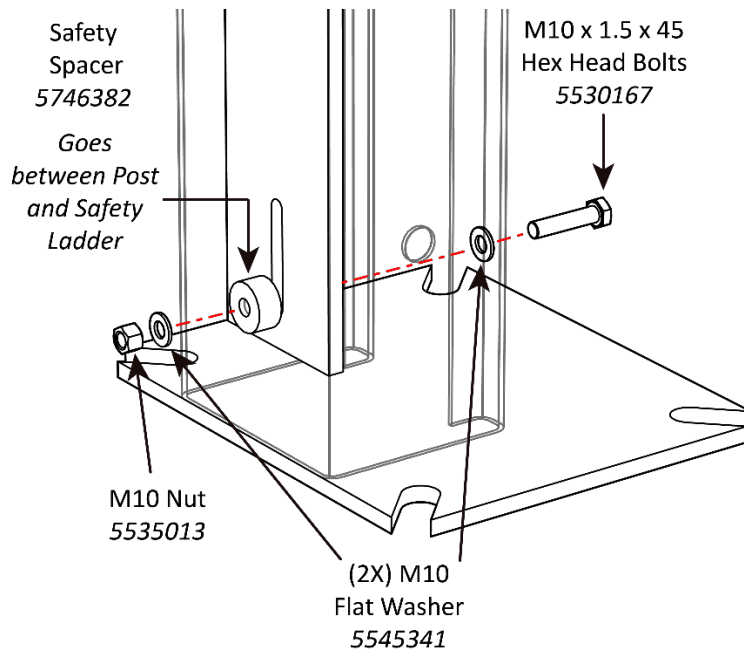

Figure to the left displays the bolted connections to make on the bottom of the Post.

Not all components are shown. Some components removed for clarity.

- Perform the same procedure to secure the other three Safety Ladders on the Lift.
- Verify the four Primary Safety Locks are engaged.

⚠ DANGER Do not continue with the installation until you have visually confirmed that all four Primary Safety Locks are engaged. If they are not engaged, the Runways could move or fall, possibly causing injury (even death) or product damage.

- If it has not already been done, stand up each Post. Have at least two people work together to stand up the Post and Crosstube.

⚠ CAUTION Use caution when walking around the Posts; they are not anchored down at this point, so it is possible to knock them over, which could cause injury.

- Use a Transit Level to estimate the Shim requirements: use a target to find the difference in height between the Posts. The difference is the estimated amount of Shim thickness you will need. Do not shim more than 1/2 in. (13 mm).

Do not tighten the nuts on the anchors at this point.

Removing the Sheaves

In order to route the Lifting Cables, first remove the Cable Sheaves on the underside of the Powerside Runway and the four Gusset Sheaves and their Lock Pins.

When removing the Sheaves, **keep the components together**. You will be reinstalling them in the same order at the same location, using the same components.

⚠ WARNING Use caution when handling the Sheave components as they can fall and become damaged, if dropped. Make sure to reinstall the Sheave Shaft Lock Screws when adjustments and installation is complete.

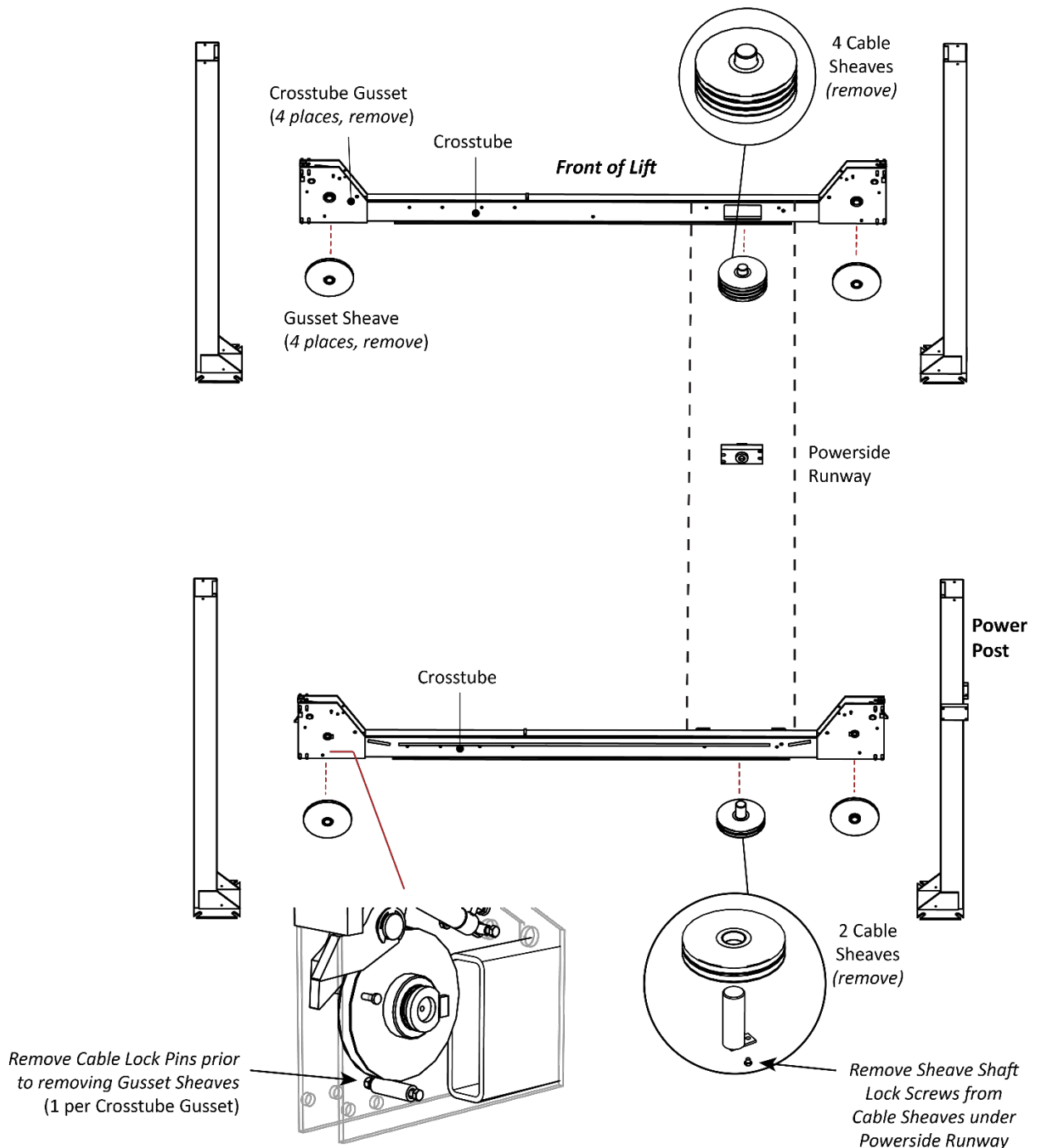

Installing the Runways

Your Lift has two Runways:

- **Powerside Runway:** Holds the Hydraulic Cylinder underneath. Includes a hole on the outside rear for the Flex Tube. Cable routing begins under the Powerside Runway.
- **Offside Runway:** The Offside Runway does not have a Hydraulic Cylinder under it, nor are there any Lifting Cables. It can be installed in the wide or narrow setting.

The figure below illustrates the correct orientation of the Runways for both Power Post locations.

Power Post: Front Driver-side

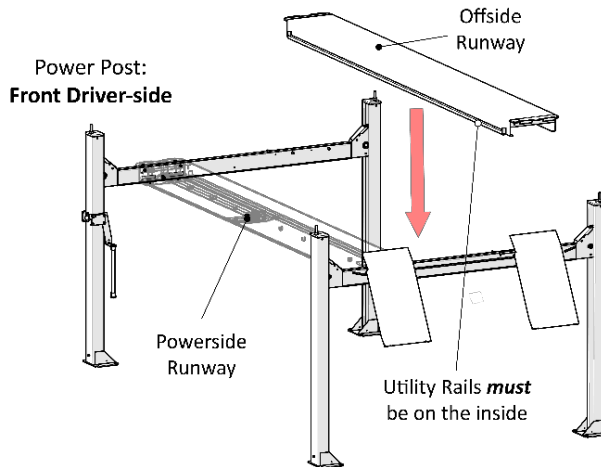

Power Post: Rear Passenger-side

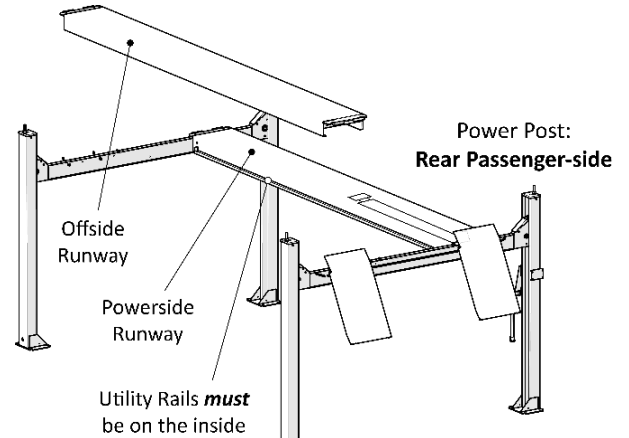

Top View. Not all components shown.

⚠ WARNING Never walk or work under the lift until all four safety locks are securely engaged.

⚠ WARNING Pay close attention when moving the Runways into position; they are very heavy, awkward and long. They could shift during movement and fall, potentially causing serious injury.

To install the Runways:

1. Correctly orient the Powerside Runway and the Offside Runway.
2. Verify the Sheaves have been removed on both ends of the Powerside Runway.

Front of Runway

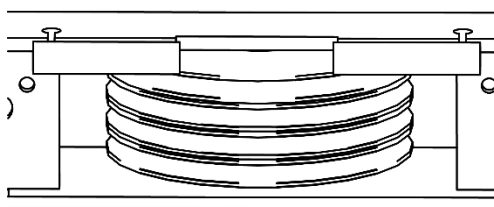

Rear of Runway

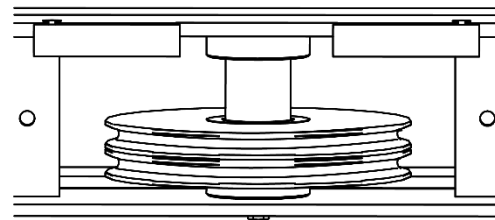

Keep the components close, you will be reinstalling them at the same location with the same components later in the installation.

3. Use a Forklift or Shop Crane to pick up the Runways, one at a time, and move them into place.

4. Bolt both Runways into place, two Hex Head Bolts on each end of the Runways.

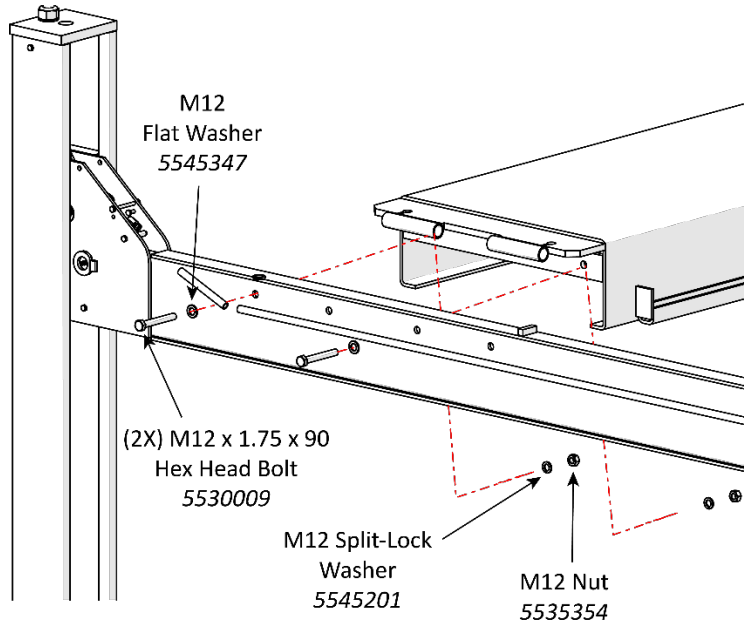

Figure to the left illustrates how to secure the Runways to the Crosstubes.

Two Bolts on each end of the Runway.

Not all components shown.

NOTICE: Both Runways **must** be bolted on both ends when using the optional Rolling Jack.

5. Verify all four Primary Safety Locks are engaged.

⚠ WARNING Do not continue with the installation until it is visually confirmed all four Safety Locks are engaged. If they are not engaged, the Runways could move or fall, possibly causing severe personal injury or product damage.

6. Before routing the Cables, extend the Piston on the Hydraulic Cylinder.

To extend the Piston:

1. Remove the Shipping Plug from the Return Line Connector.

The Return Line Connector is on the Cylinder end closest to where the Power Unit will be.

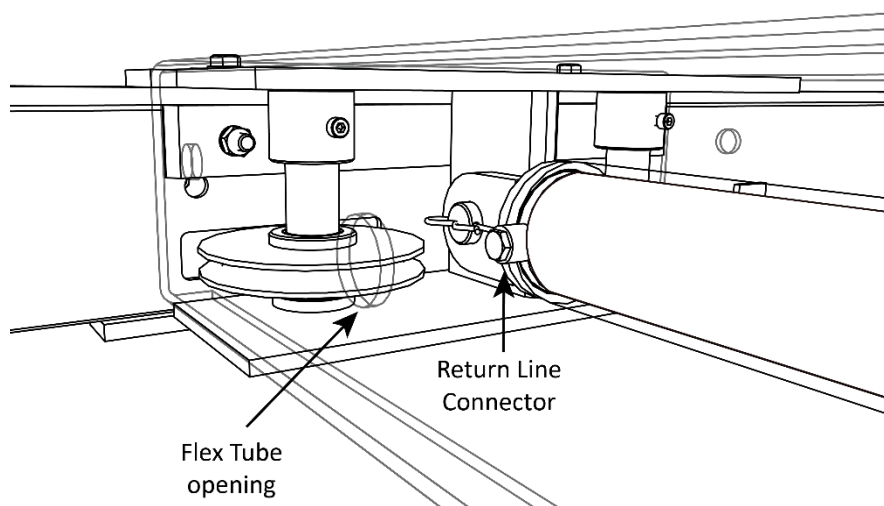

2. Attach an air pressure source to the Return Line Connector.
3. Use the air pressure to extend the Hydraulic Cylinder's Piston and Retaining Block.

Do not exceed 50 psi.

If the Cylinder does not move, stop using air pressure; instead, use a pulling device (such as a Come Along Tool) to extend the Piston and Retaining Block; use care not to damage the Piston.

4. Disconnect the Air Line and reinstall the Shipping Plug to the Return Line Connector.

Routing the Lifting Cables

The following drawing shows **all four Cable routes** in one drawing.

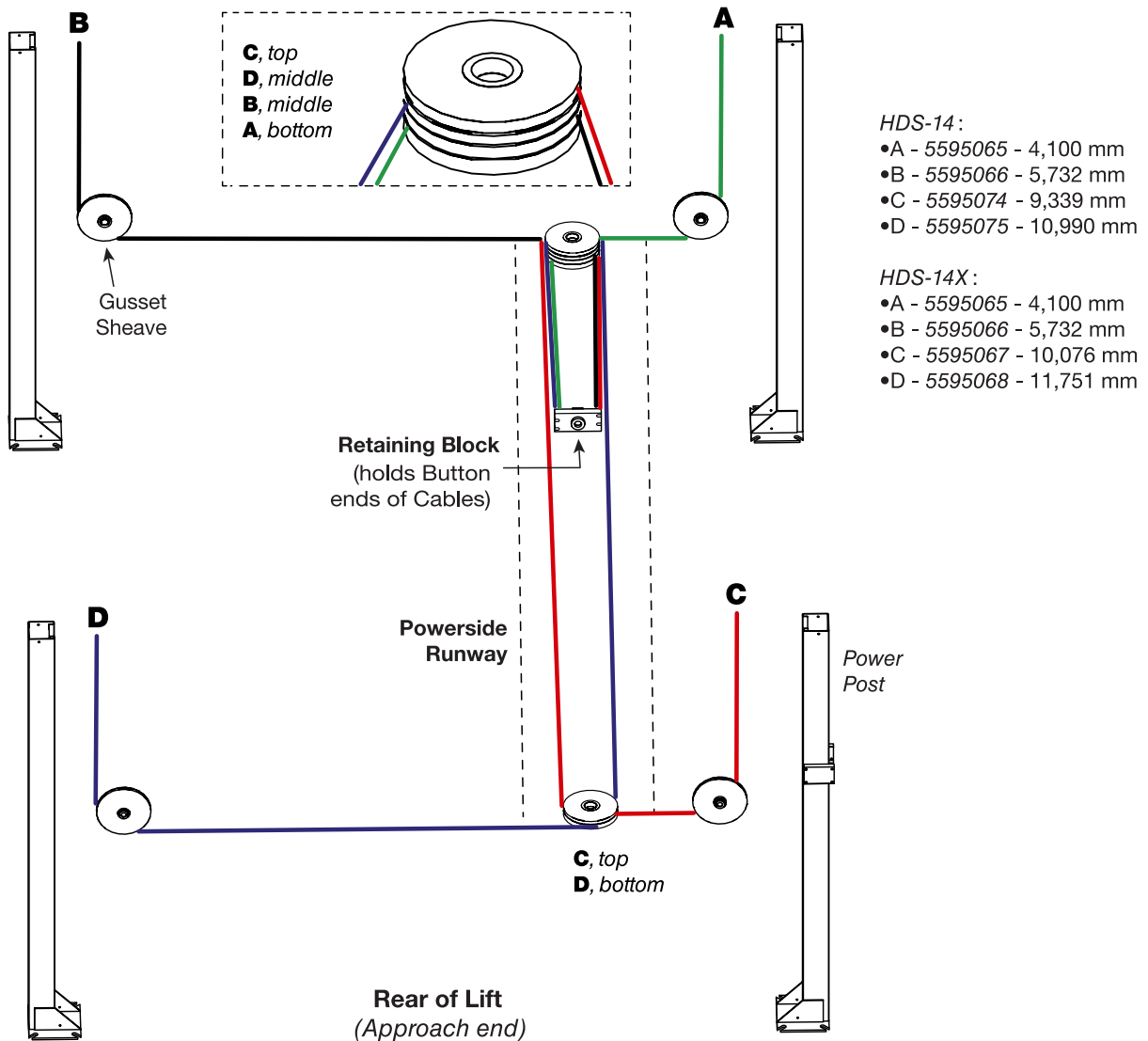

The following illustration displays the Cable Sheave Pairings underneath the Powerside Runway.

Lubricate the Cable Sheave Pins and Bores with Red Lithium Grease.

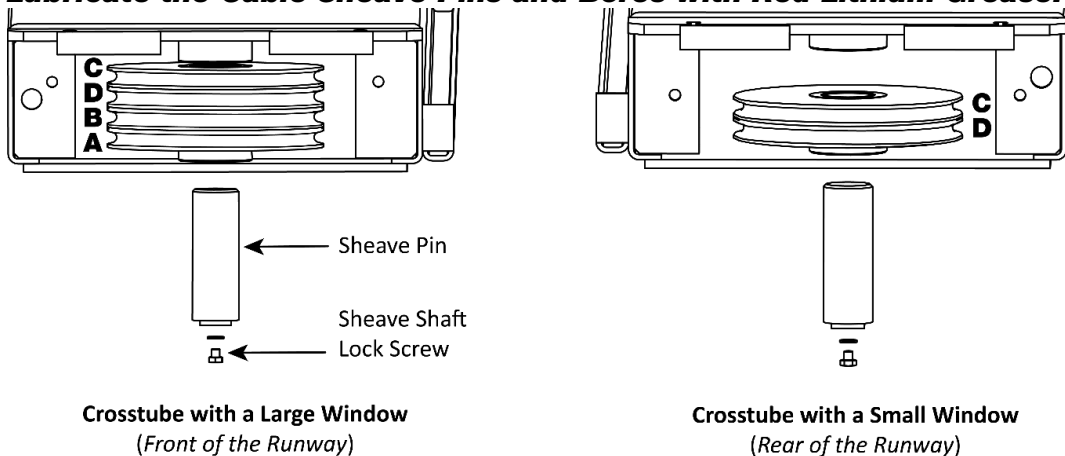

⚠ WARNING Failure to route the Lifting Cables as described may lead to equipment damage and/or serious personal injury to anyone near the Lift.

The following procedure assumes the four Lifting Cables and Sheaves removed prior to installing the Runways are near at hand.

To route Lifting Cables A and C:

1. **Starting with Lifting Cable A**, remove the Nut and Washer from the Threaded End (but keep it nearby). Check the label to verify the correct Lifting Cable is being installed.
2. Route the Threaded End of Lifting Cable A into its Large Window on the Crosstube, push it towards Post A, and then pull the Threaded End out of the Crosstube at the bottom of the Gusset.
3. Route the Threaded End of Lifting Cable A under where the Gusset Sheave will go when it is reinstalled, then route it up past the top of the Crosstube Gusset.

The figure below details the Lifting Cable route through the Gusset.

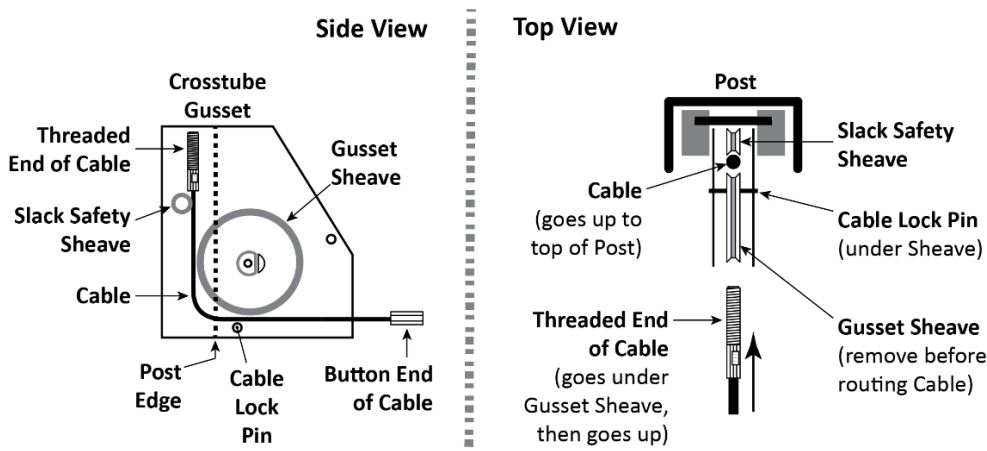

NOTICE: When routing a Lifting Cable in its Post, the Cable must run **under** the Gusset Sheave on the side of the Slack Safety Sheave. When the Cables are pulled tight, the Cable prevents the Slack Safety from engaging. If the Cable is **not in this exact location**, the Slack Safeties will **not** function correctly.

4. With the Lifting Cable in place, reinstall the Gusset Sheave (lubricate the pin and bore with Red Lithium Grease) and the Cable Lock Pin in Post A.
5. Verify that Lifting Cable A is in the correct position: in between the Gusset Sheave and the Slack Safety Sheave, with the Cable Lock Pin **under** it.
6. Push the Threaded End of Lifting Cable A up to and through the Top Cap at the top of the Post and **hand tighten** it in place with the Nut and Washer removed earlier. Only hand tighten the Nut until there is still a little play in the cabling. All four Cable nuts will be adjusted after the Final Leveling.

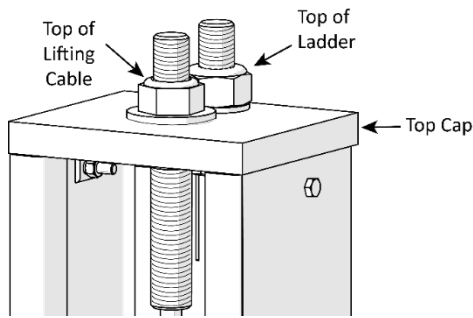

Drawing shows the Threaded end of the Lifting Cable in position in the Top Cap.

View is from the top of the Post.

Not all components are shown.

7. **Switching to Lifting Cable C**, repeat Steps 1 through 7 for Lifting Cable C, starting at the Small Window near the bottom of Post C (the Power Post).
8. Position the Double Cable Sheave in the Crosstube with a Small Window and then make sure Lifting Cable C is correctly positioned in the Top Cable Sheave in the Small Window.
9. Under the Powerside Runway, move the rest of Lifting Cable C back towards the Crosstube with a Large Window.
10. Visually inspect that Lifting Cable A is seated in the **Bottom** Sheave and Lifting Cable C is seated in the **Top** Sheave, as shown below.

The following illustration shows a detailed view of the **Retaining Block** and **Retaining Plate**.

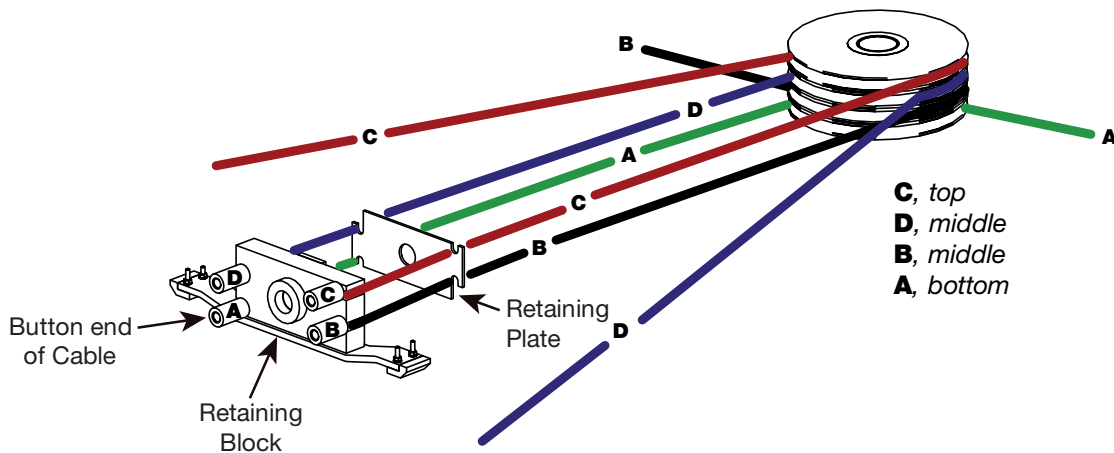

11. Near the Hydraulic Cylinder, loosen the Retaining Plate enough to provide room to slip the Button End of each Cable into its slot on the Retaining Block.

Do not remove the Retaining Plate, just loosen it.

12. Pull the Button Ends of Lifting Cables A and C back towards the middle of the Runway, past the Retaining Plate, and into its slot on the Retaining Block.

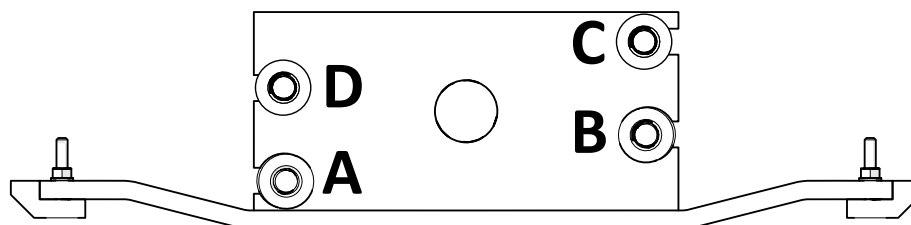

Figure shows the Retaining Block Button ends facing the viewer.

Not all components are shown.

Lifting Cables A and C are now correctly routed to their Posts.

NOTICE: Routing Lifting Cables B and D is the same process as routing Lifting Cables A and C, just to the other two Posts and using a different set of Sheaves. Refer to the figures in the previous section.

CAUTION After routing the Lifting Cables, visually inspect that all four Lifting Cables are properly positioned and remain within the grooves of **all** Sheaves. Make sure to tighten the Sheave Shaft Lock Screws.

Working with Compression Fittings and Tubing

The Lift is delivered with a roll of 1/4 in., black, polyethylene Tubing (also called Poly-Flo® Tubing) that is used with Compression Fittings for the Return Line and for the Air Lines.

Important: While both lines use Tubing and Compression Fittings, the Return Line and Air Lines are used for completely separate purposes; do not connect the two together.

Note: Compression Fittings are different from Hydraulic Fittings. This section covers Compression Fittings only.

The components involved with Compression Fittings include:

- **1/4 in. black, polyethylene Tubing.** Use a single piece of Tubing for the Return Line. The Air Lines require multiple Tubing pieces. Create the Tubing pieces for both the Return Line and the Air Lines by cutting lengths from the long roll of Tubing supplied with your Lift.
- **Elbow Compression Fittings.** The Hydraulic Cylinder uses an Elbow Compression Fitting and then one Elbow Compression Fitting goes on the Power Unit.
- **Tee Compression Fittings.** The Air Line segments require three Tee Compression Fittings.
- **Nuts, Ferrules, Rods, and Threads.** Each connector on Elbow and Tee Compression Fittings have a Nut, Ferrule, Rod, and Threads (see drawing below). The Nut holds the Tubing and Fitting together. The Ferrule compresses when you tighten the Nut on the Threads to make a secure connection. The Rod goes inside the Tubing so that nothing leaks out.

The following drawing shows the components of a connector on a Tee Compression Fitting.

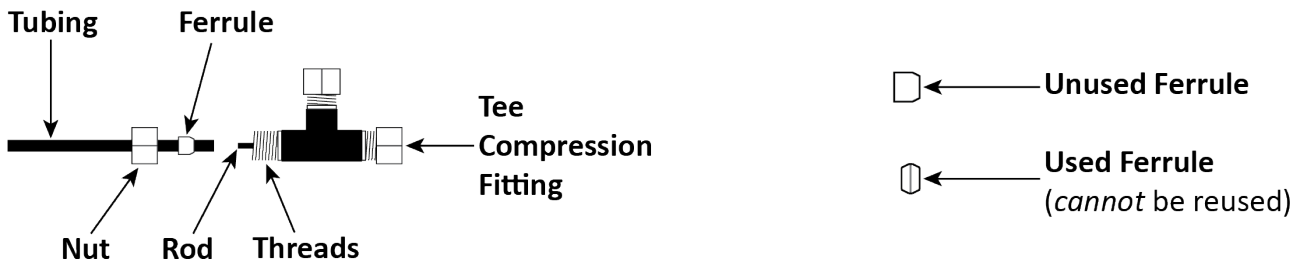

NOTICE: **Ferrules can only be tightened once.** When you tighten the Nut on the Threads, the Ferrule gets compressed; it literally changes shape and **cannot** be used again.

To connect Tubing to a Compression Fitting:

1. Push the Tubing through the Nut and over the Rod.
Do not push hard; the Tubing need only to go a little way over the Rod. The Ferrule is not seen at this point, but the Tubing must route through the Ferrule and over the Rod.
2. Slide the Nut on the Tubing **away from the Fitting**; if the Nut is still on the Threads, unscrew it from the Threads and then slide it away from the Fitting. See the drawing above.
3. Slide the Ferrule over the Tubing, away from the Fitting and towards the Nut.

4. With the Nut and the Ferrule out of the way, push the Tubing further over the Rod until it stops.

5. Slide the Ferrule and the Nut back to the Threads on the Fitting.

The Ferrule routes around the Rod and under the Threads. The Nut is tightened onto the threads.

6. Tighten the Nut.

Remember that the Ferrule can only be used once; do not tighten the Nut until everything is ready.



IMPORTANT! PLEASE READ NOW



Hydraulic Fluid Contamination

Hydraulic Fluid Contamination poses a **serious** issue for the Lift; contaminants such as water, dirt, or other debris can get into the Hydraulic Hoses and Fittings on the Lift, making it inoperable.

The Lift is shipped with clean components; however, BendPak strongly recommends that you take secondary precaution to clean all Hydraulic Hoses and Fittings prior to making connections. It is better and less costly to take these extra steps now so that there is no need to take your Lift out of service later to fix issues that could have been prevented at the time of installation.

There are several ways to clean Hydraulic Hoses and Fittings:











- **Compressed Air.** Use an air compressor to blow out contaminants from each Hydraulic Hose and Fitting prior to installation. Clean, dry air is preferred. Wear eye protection (safety glasses, goggles, or face shield) when using compressed air for cleaning. Never point an air hose nozzle at any part of your body or any other person.
- **Fluid Flushing.** As long as the Hydraulic Fluid is clean and compatible with the system fluid, flush Hoses and Fittings to create turbulent flow and remove particulates. Always ensure that the fluid itself is contaminant-free.

Some additional steps that will help keep the Hydraulic Fluid clean:

- **Remove old thread seal tape.** Some ports on the Hydraulic Cylinders are shipped with temporary plugs secured with thread seal tape, so make sure to thoroughly remove any leftover thread seal tape that may inadvertently enter the Hydraulic System.
- **Use a liquid thread sealant only.** Teflon paste-type thread sealant or Loctite™ 5452 thread sealant is recommended for all NPT Fittings. Do not over tighten NPT Fittings or they may crack. Never use thread seal tape on JIC Fittings or ORB O-Ring Fittings.
- **Always use clean equipment.** If a dirty bucket or funnel is used to transfer the Hydraulic Fluid into the Hydraulic Fluid Reservoir, the contaminants will likely be introduced into the Fluid. When using cleaning rags, use a lint-free rag.
- **Proper storage.** Keep the Hydraulic Fluid sealed in its container until ready for use; store the Fluid in a clean, dry, and cool area.
- **Cover the Hoses and Fittings.** Before installation, do not leave the ends of the Fittings exposed; the same applies for the Hydraulic Hoses. As a general rule, keep the Hydraulic Hoses and Fittings capped and kept clean in a clean area until ready for use.
- **Filter the new Hydraulic Fluid.** Just because it is new does not necessarily mean it is *clean*. Use an offline filtration cart or kidney loop system to make sure the Hydraulic Fluid is clean before being transferred into the Hydraulic Fluid Reservoir (even using a heavy duty nylon mesh screen is better than trusting what is left at the bottom of the barrel).
- **Avoid mixing different types of Hydraulic Fluid.** If Hydraulic Fluid needs to be replaced, make sure to flush the old Hydraulic Fluid out of the system before adding the replacement Fluid; do not mix the two together.

Hydraulic System Dangers and Warnings

Before applying power to the Hydraulic System, note the following Dangers and Warnings:

-  **DANGER** Failure to observe these warnings can result in serious personal injury including, in rare cases, death.
-  **DANGER** The Power Unit is a Hydraulic Pump capable of developing pressures in excess of 5,000 psi (345 BAR). A pressure relief valve is used to set the pressure at the desired level. Tampering with, adjusting, modifying, or removing the relief valve is extremely dangerous and is not permitted. Only trained Hydraulics technicians are permitted to adjust the relief valve, using calibrated hydraulic pressure gauges to ensure the proper pressure setting is achieved.
-  **DANGER** Changes to the output pressure may render the power unit incompatible with pressure limitations of other components in the hydraulic circuit. This may cause catastrophic failure of those components, and could result in property damage, severe personal injury, or death.
-  **DANGER** The Hydraulic System can contain high pressure which, if suddenly released, can cause severe injury or death.
-  **WARNING** The Hydraulic hoses and connections **must** be inspected before any attempt to raise a Vehicle is made.
-  **WARNING** **Verify** all Hydraulic Hose connections and fittings, including unused auxiliary port plugs on the Power Unit, the Flow Divider, the Cylinders and anywhere else in the Hydraulic System are tightened.
-  **WARNING** Do **not** attempt to connect or disconnect Hydraulic Hoses while the equipment is loaded or while a Vehicle is on the Lift or the Hydraulic System is under pressure.
-  **WARNING** Keep bare hands away from Hydraulic Fluid; always wear gloves when handling Hydraulic Fluid, Cylinders or Hydraulic Hoses.
-  **WARNING** When handling Hydraulic Fluid, always observe the manufacturer's safe handling instructions found in their Material Safety Data Sheet (MSDS).
-  **WARNING** **Always** promptly clean any Hydraulic Fluid spills. If a leak is the source of the spill, lockout the Lift to prevent use until the Hydraulic System is repaired.

About Thread Sealants

Liquid Thread Sealant lubricates and fills the gaps between the **NPT Fitting** threads and leaves no residue that could otherwise contaminate the Hydraulic Fluid.

Other types of Thread Sealants (like Teflon Tape) can shred during installation or removal and eventually enter the Hydraulic System.

Liquid Thread Sealant is largely designed for use with NPT connectors.

Apply the thread sealant when the ambient temperature is between +46.5°F to +70°F (+8°C to 21°C)

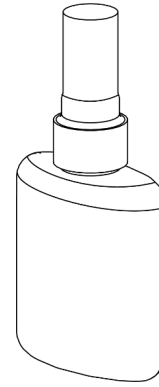

To apply Thread Sealant:

1. Make sure the Fittings and connectors are clean and dry.

If adding Thread Sealant to a Fitting or connector that has already been used with a different sealant, use a wire brush to thoroughly remove the old sealant before adding more.

2. Skipping the first thread, apply a small amount of Thread Sealant to the next four threads of the Fitting.

⚠ WARNING Always wear the proper protective equipment when handling Thread Sealant.

Only a small amount of sealant is required as it will spread to the other threads as the fitting is tightened into place.

If too much sealant is used, the excess liquid will be pushed out when the Fitting is tightened; use a rag to wipe away the excess.

3. Tighten the Fitting into the connector; do **not** over tighten the Fitting.
4. Allow the **24-hour** manufacturer-recommended curing time before pressurizing the system.

Identifying Hydraulic Fittings

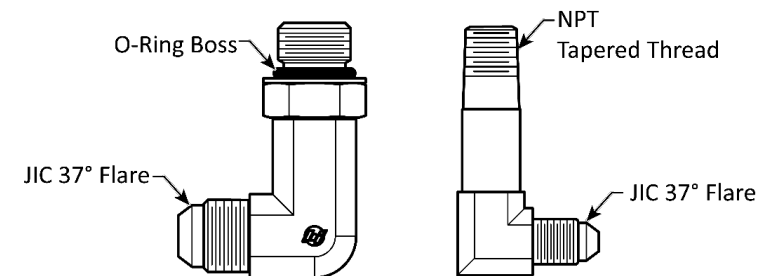

Joint Industry Council (JIC)

Installing the Hydraulic Hose

The Hydraulic System moves hydraulic force from the Power Unit to the Hydraulic Cylinders, which use that force to raise and lower the Runways.

To install the Hydraulic Hose, the following components are required:

- **The Hydraulic Hose.** HDS-14 (5570152) / HDS-14X (5570151) / HDS-14XT (5570306). The Hydraulic Hose has a Curved end and Straight end.
- **JIC to NPT Hydraulic Elbow Fitting.** 5550106. The JIC end goes to the Hydraulic Hose and the NPT end goes to the Hydraulic Cylinder.
- **JIC to ORB Hydraulic Elbow Fitting.** 5550008. The JIC end connects to the Hydraulic Hose and the ORB end connects to the Power Unit. *Not connected at this point.*

The following drawing shows the connections to make to the Hydraulic Hose.

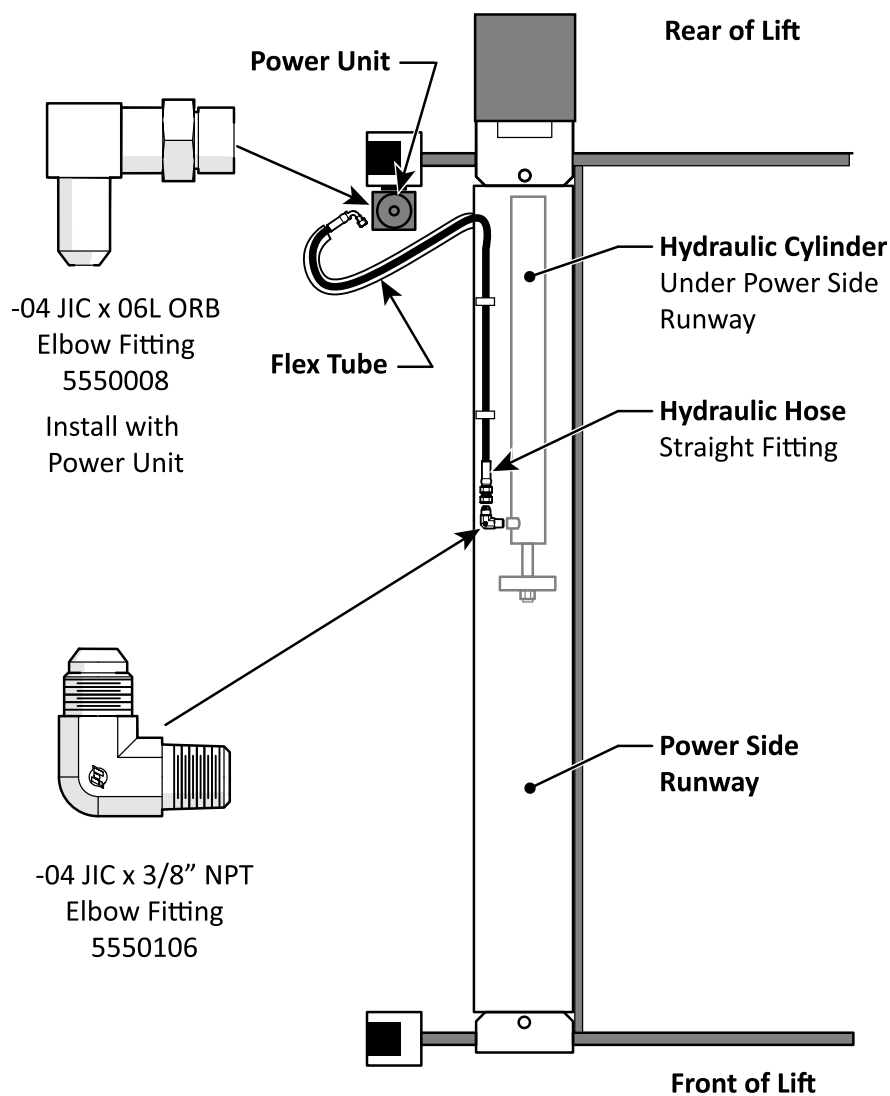
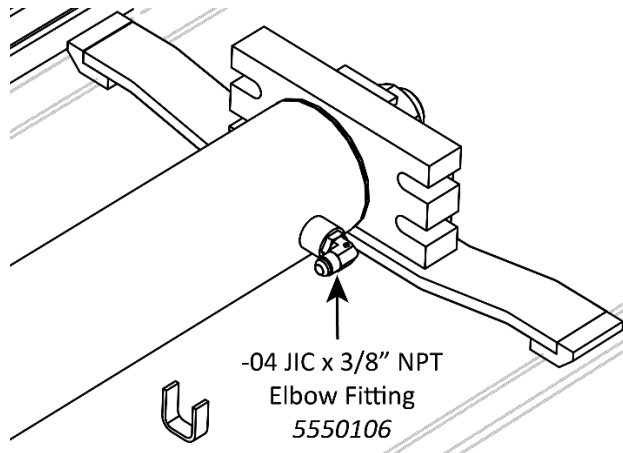

Figure above represents a top view of the Powerside Runway. Not all components shown.

To install the Hydraulic Hose:

1. Locate the Hydraulic Hose and a Hydraulic Elbow Fitting (5550106).
2. Prepare the Hydraulic components using the information in **Hydraulic Fluid Contamination**.
3. On the Hydraulic Cylinder, remove the Shipping Plug from the Port at the Piston Rod end.
4. Attach the NPT end of the Elbow Fitting to the Port and tighten it.

Use Thread Sealant on NPT Threads only.



View is looking through the Powerside Runway. Not all components are shown.

5. Pass the straight end of the Hydraulic Hose through the Flex Tube and up into the Power Side Runway.
6. Attach the Straight end of the Hydraulic Hose to the JIC end and tighten it.
7. Take the Curved end of the Hydraulic Hose and, starting at the Hydraulic Cylinder, route the Curved end through the Retaining Rings along the inside edge of the Runway and then through the Flex Tube opening.

NOTICE Once completed, the hydraulic hose radius end should be exiting the Flex Tube opening near the Power Unit.

8. The radius end of the Hydraulic Hose will be connected to the Power Unit later in the process.

Installing the Return Line

The Return Line takes excess Hydraulic Fluid coming out of the Hydraulic Cylinder and sends it back into the Fluid Reservoir on the Power Unit.

To install the Return Line, retrieve the following components:

- **The Return Line.** 5570795. The Return Line is a single piece of 1/4 in., black, Poly-Flo Tubing and Elbow Compression Fittings on each end. Measure and cut a piece of the supplied Tubing to the length required to create the Return Line.
- **(2X) COMP to NPT Hydraulic Elbow Fittings.** 5550089. The compression end connects the Poly-Flo Return Line and the NPT end connects to the Power Unit and the Hydraulic Cylinder.

Important: The Return Line uses the same 1/4 in., black, Poly-Flo Tubing as the Safety Lock Air Lines. **Do not** confuse the two; the Return Line and the Air Lines do completely different things and **must** be kept separate from each other.

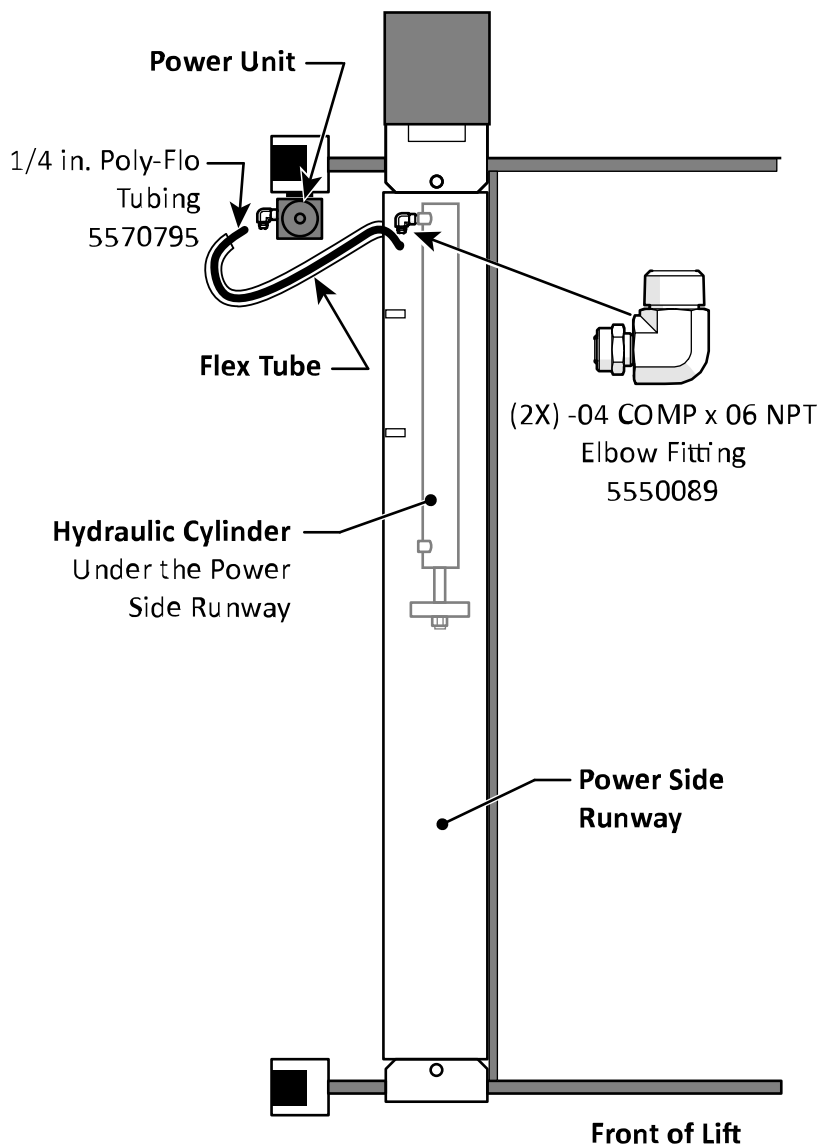

The figure above is a top view of the Powerside Runway. Not all components shown.

To install the Return Line:

1. Measure the distance from the Return Line Port on the Hydraulic Cylinder to the Return Line Port on the Power Unit.
2. Cut a piece of Tubing to the measured length from the roll delivered with the Lift.
It is better to cut the Tubing a little too long rather than a little too short.
3. Route the Tubing from the Hydraulic Cylinder through the Flex Tube, and out to where the Power Unit will be installed.
4. Remove the Shipping Plug from the Return Line Port on the Hydraulic Cylinder, then connect and tighten the Compression Elbow Fitting (5550089) into the Return Port.

Use Thread Sealant on NPT threads only.

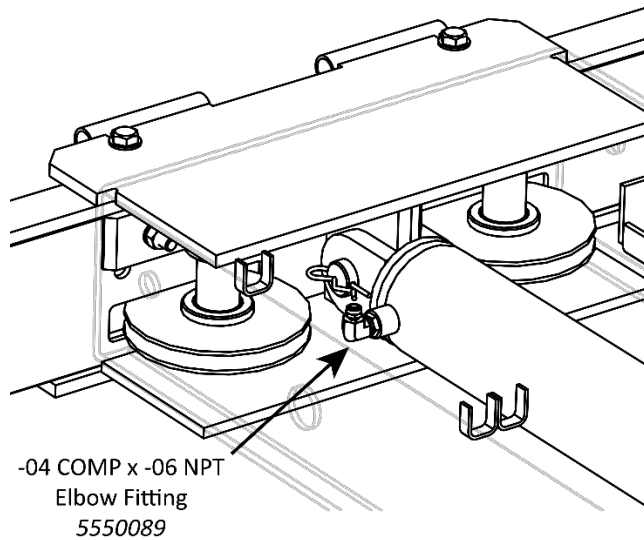

View looking through the Powerside Runway, near the Cylinder end. Not all components shown.

5. Connect one end of the Return Line to the COMP end of the Fitting.
Refer to **Working with Compression Fittings and Tubing** for instructions.
6. Leave the Power Unit end of the Return Line hanging out of the Flex Tube opening for the moment.

Installing the Air Lines

The Air Lines deliver compressed air used to disengage the Safety Locks on each Lift Post to lower the Runways. Use the 1/4 in. (6 mm), black, polyethylene Tubing (5570795) that came with the Lift and three Air Line Tee Connectors to install the Air Lines.

An Air Supply (3 to 25 cfm at 50 – 150 psi) is required to disengage the Safety Locks.

⚠ CAUTION **Do not let the Air Supply exceed 150 psi;** the Air Lines could burst or the Safety Locks malfunction.

The Air Line Elbow Connectors on the Air Cylinders come installed from the factory.

⚠ CAUTION Do not confuse the Air Lines with the Return Line. They use the same Tubing and similar-looking connectors, but they are used for completely different things; the two systems cannot be connected to each other.

The Compression Elbow Fittings on the Crosstube Gussets are delivered already installed from the factory.

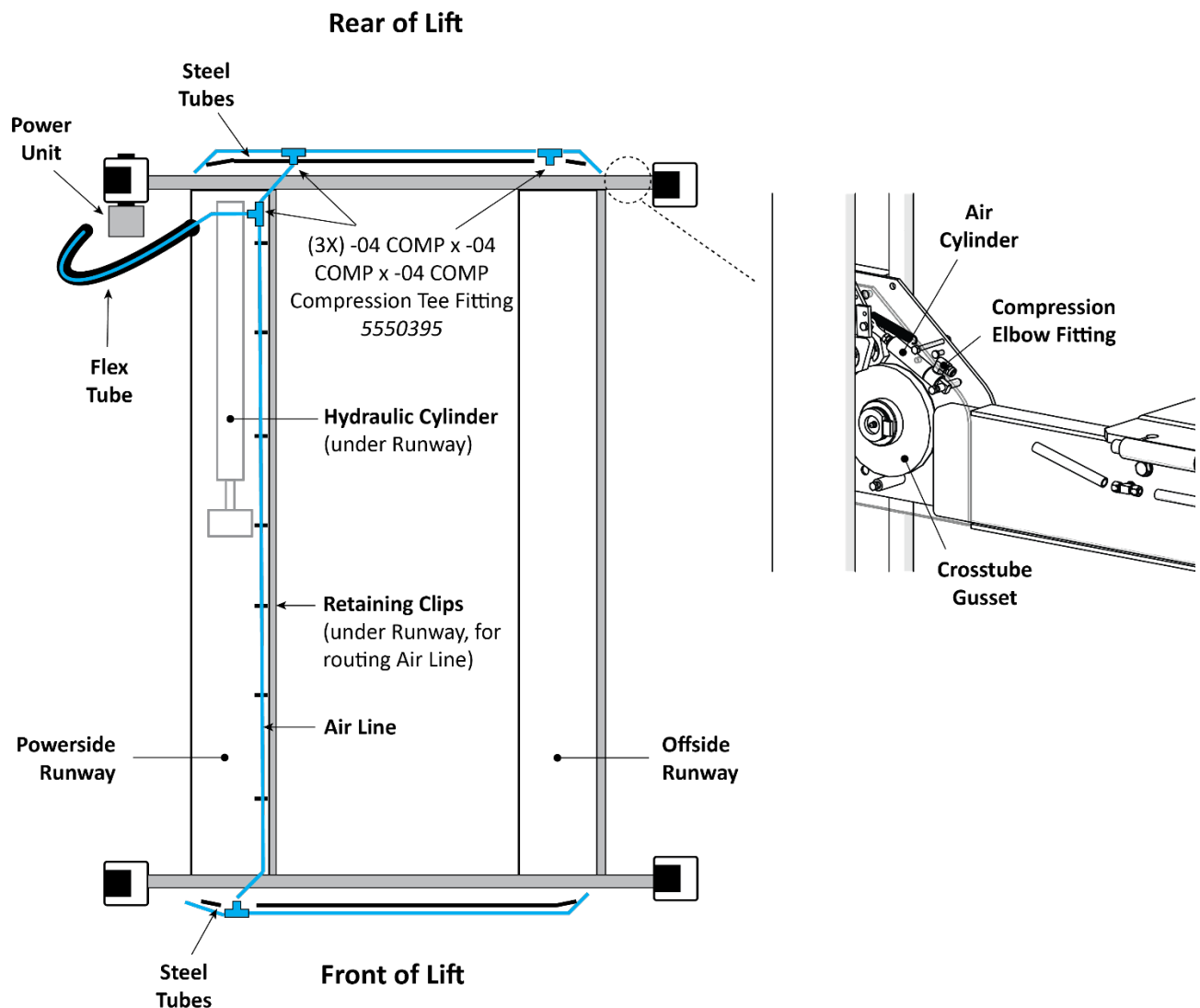

Air Lines shown outside Steel Tubes for clarity. Drawing not to scale. Some components not shown.

To install the Air Lines:

1. Find the roll of supplied 1/4 in., black, polyethylene Tubing and three Tee Compression Fittings.
2. Measure the distances for each of the seven (7) Tubing pieces required for the Air Lines. Refer to the previous figure for the locations of the Tubing pieces.
3. Cut seven pieces of Tubing to the measured lengths from the roll of Tubing.
4. Connect the various pieces of Tubing to the Tee Compression Fittings on the Lift, as shown in the figure on the previous page detailing the locations of the Tubing pieces.

Make sure to position the three Tee Compression Fittings as shown in the previous figure.

5. Route the long Tubing piece routed under the Powerside Runway through the Retaining Clips. These Clips keep the Air Lines away from the Lift Cables.

 **WARNING** Make sure to route the Tubing pieces on the **outside** ends of the Front and Rear Crosstubes through the Steel Tubes on the ends of the Crosstubes. These tubes keep the Air Lines and the Tee Connectors from being damaged as the Lift is in use. If the Air Lines are damaged, the Safety Locks on the Lift may not function correctly. If the Tubing has become disconnected or damaged, take the Lift out of service and until the Air Lines are repaired.

Refer to **Working with Compression Fittings and Tubing** for more information about connecting the Tubing to the Tee Compression Fittings.

6. Leave the Power Unit end of the Air Line hanging out of the Flex Tube opening for now. It will be connected to a Tee Compression Fitting and the Pushbutton Air Valve later.

Installing the Power Unit

This section describes how to **install**, but not make the connections to, the Power Unit for this Lift. An Electrician is **not** required to install the Power Unit; one is required to connect the Power Unit to its power source.

The Power Unit **must** be installed on the Power Post; attach it to one of the two Mounting Brackets, whichever is more convenient for the installation.

⚠ DANGER Risk of explosion: The Power Unit has internal arcing or parts that may spark and should not be exposed to flammable vapors. **Never expose** the Power Unit motor to rain or other damp environments. Damage to the motor caused by water is **not** covered by the warranty. **Never mount** the power unit motor lower than 18 in. above the ground.

⚠ CAUTION The Power Unit is heavy. BendPak recommends one person hold the Power Unit while another person bolts it in to place.

The figure below details attaching the Power Unit to the Power Post.

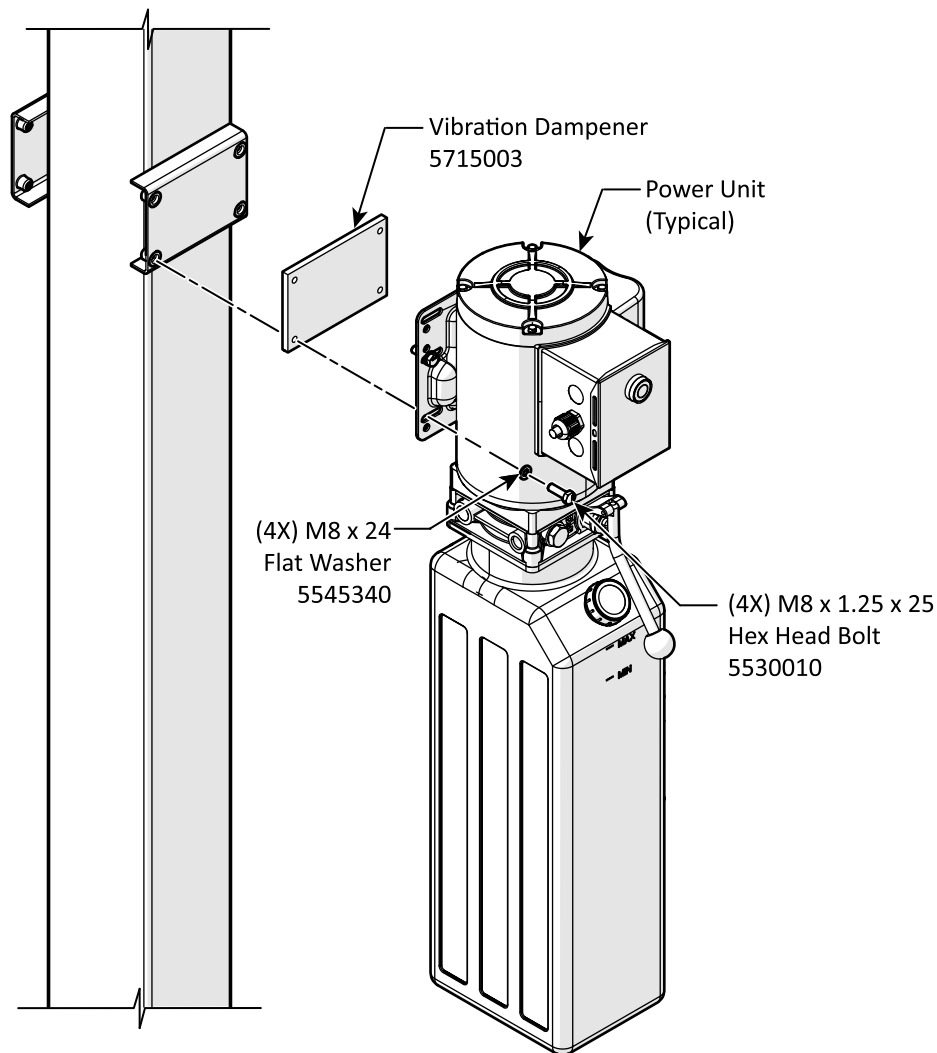

NOTICE Typical Power Unit pictured. The Power Unit delivered with the Lift may differ from the figures in this manual.

To install the Power Unit:

1. Retrieve the Power Unit, Vibration Dampener, and the required M8 hardware.
2. Line up the openings on the Mounting Plate and Vibration Dampener with the four holes in the Mounting Bracket. Use all four holes to secure the Power Unit.
3. Secure the Power Unit and Vibration Dampener to the Mounting Plate using the supplied fasteners.

Filling the Hydraulic Fluid Reservoir

Fill the Power Unit with an approved Hydraulic Fluid.

Approved hydraulic fluids include any general-purpose AW-32 hydraulic oil, and any synthetic multi-vehicle automatic transmission fluid.

 **DANGER** Always refer to the lubricant and hydraulic fluid manufacturer's Material Safety Data Sheet (MSDS) for information on the proper handling and disposal of chemicals.

 **WARNING** Do not run your Power Unit without Hydraulic Fluid; you will damage it.

To fill the Hydraulic Fluid Reservoir:

1. Remove the Reservoir Cap and set it aside.
Take care to **keep contaminants out** of the Hydraulic Fluid Reservoir.
2. Fill the Hydraulic Fluid Reservoir on the Power Unit with the appropriate amount of Hydraulic Fluid.
The Hydraulic Reservoir holds from 3.6 to 4.5 gallons, depending on your Power Unit.
 - **5585285**: 3.7 gallons (14 liters)
 - **5585785**: 3.6 gallons (13.5 liters)
 - **5585175**: 4.5 gallons (17 liters)
 - **5585780**: 3.6 gallons (13.5 liters)
 - **5585229**: 3.7 gallons (14 liters)
 - **5585247**: 3.7 gallons (14 liters)
 - **5585176**: 4.5 gallons (17 liters)
3. When the Reservoir is filled, replace the Reservoir Cap.

Do not connect the Power Unit to a power source at this point.

Installing the Flex Tube

To connect the Flex Tube to the Power Unit, first connect the Flex Tube Bracket and the Flex Tube Angle Bracket.

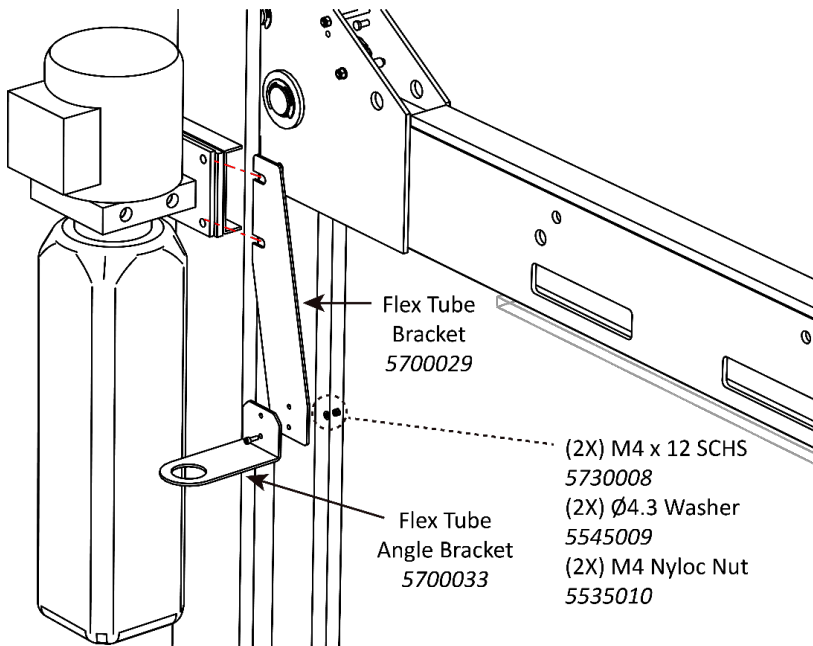

BendPak recommends orienting the Flex Tube so that the Hydraulic, Pressure and Return Lines exiting the Flex Tube are near where it connects on the Power Unit and to the Pushbutton Air Valve.

To connect the Flex Tube:

1. Retrieve the Flex Tube Bracket and the Flex Tube Angle Bracket and Flex Tube from the Parts Box.
2. Install the Flex Tube Bracket Plate. Location options are between the Mounting Bracket and the Back Plate or between the Back Plate and the retaining Nut.

NOTICE It is common to install the Flex Tube Bracket Plate between the Mounting Bracket and the Back Plate. This allows the Zero Angle Bracket (which holds the Pushbutton Air Valve and is described in the next section) to be installed between the Back Plate and the retaining Nut. This configuration is common, but not required.

3. Connect the Flex Tube Angle Plate to the Flex Tube Bracket Plate using two Bolts, Washers, and Nuts. The Flex Tube Angle Plate can be connected on either side of the Flex Tube Bracket Plate.
4. When the Flex Tube Angle Plate is in place, unscrew the Plastic Collar of the Flex Tube.
5. Holding the Flex Tube by the Plastic Collar, put the Threads through the hole on the Power Side Runway.
6. Slide the Flex Tube over the Hydraulic, Pressure, and Return Lines and twist into the plastic connector on the Powerside Runway.
7. Find the Flex Tube length in the **Table**.
8. Measure, mark, then cut the Flex Tube at the correct length for your Lift. Cut to the length indicated $\pm 25\text{mm}$ (± 1 in).

Flex Hose Length Table		
Model	In.	mm
HDS-14	52	1320
HDS-14X	52	1320
HDS-14XT	64	1626

9. Secure the other end of the Flex Tube to the Angle Plate **from underneath**.
10. Screw the Plastic Nut back onto the threads and tighten.

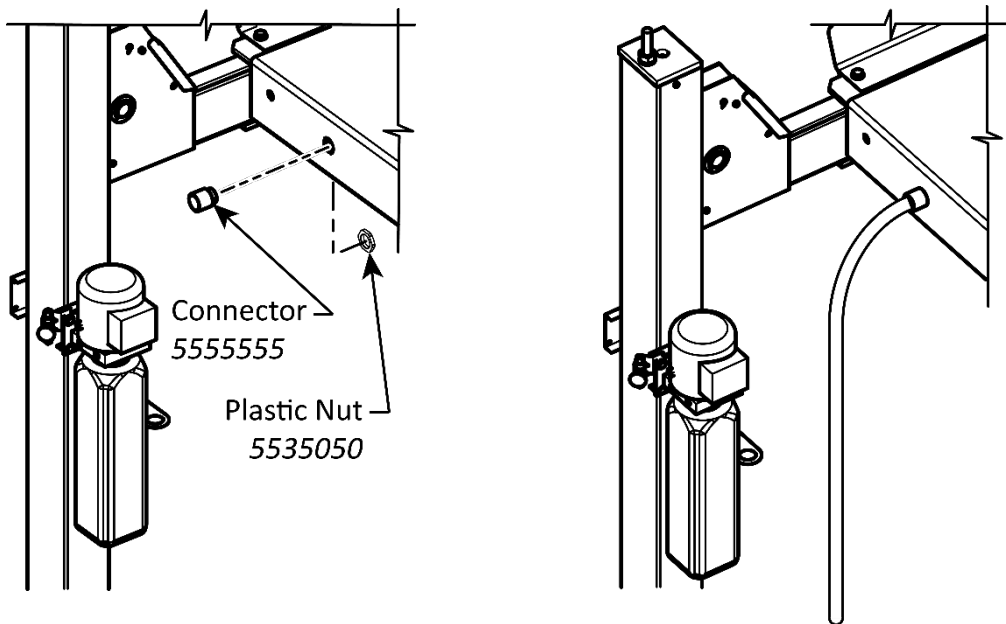

Installing the Pushbutton Air Valve

The Pushbutton Air Valve is used to lower the Runways. It can go on either side of the Power Unit, but we recommend placing it on the side facing away from the Lift to be out of the way.

For the customer-supplied air pressure, a minimum of 50 to 150 psi / 3 to 25 cfm is required.

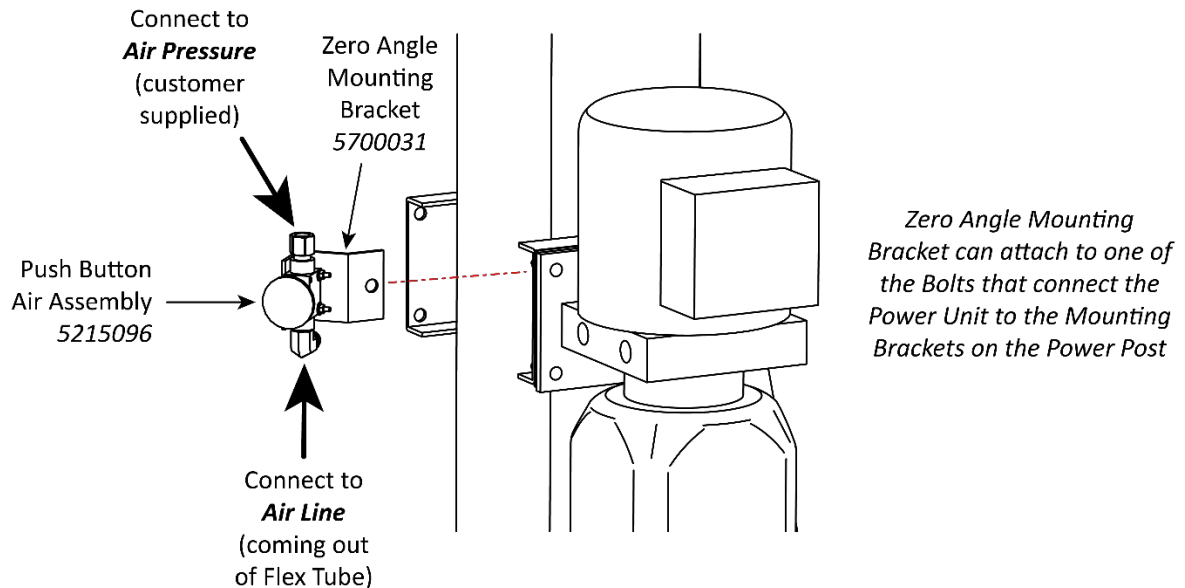

Drawing shows the Pushbutton Air Valve Assembly and its connections to the Mounting Bracket on the Power Post. Not all components shown. Sample Power Unit shown.

To install the Pushbutton Air Valve:

1. Find the necessary components: Zero Angle Bracket and the Pushbutton Air Valve Assembly.
2. Connect the Zero Angle Bracket at the desired location.

The best location is one that is visible and easily reached by the Lift operator.

3. Connect the Pushbutton Air Valve to the Zero Angle Bracket.

Use the two holes on the Pushbutton Air Valve on the side away from the actual pushbutton. If the holes next to the pushbutton are used, the Zero Angle Bracket interferes with the pushbutton when attempting to use it.

4. Connect the Air Line Compression Elbow Fitting and the Straight Expander Fitting to the appropriate locations on the Pushbutton Air Valve.

The Elbow Fitting connects to the opening labelled **CYL**. The Straight Fitting to the opening labelled **IN**. See the drawing above.

5. Attach the Air Line to the Compression Fitting and the customer-supplied air to the Straight Fitting.

Important: The Return Line also comes out of the Flex Tube and is the same kind of tubing as the Air Line. **Do not attach the Return Line to the Pushbutton Air Valve by mistake.** Double check to make sure you are attaching the Air Line to the Pushbutton Air Valve.

Connecting the Return Line

One end of the Return Line is already connected to the Hydraulic Cylinder; the other end of the Return Line needs to be connected to the Power Unit's return port.

To attach the Return Line to the Power Unit:

1. Remove the Shipping Plug from the Hydraulic Return Port on the Power Unit, then attach a 04 COMP – 06 NPT Elbow Compression Fitting (5550089) to the Port.

Use Thread Sealant on NPT Threads only.

2. Attach the Return Line (coming out of the Flex Tube) to the other end of the Fitting.

For information about connection compression fittings, refer to **Working with Compression Fittings and Tubing**.

See **Connecting the Power Source** for the possible connector locations.

Important: Make sure you are attaching the Return Line to the Power Unit and not the Air Line. **Do not attach the Air Line to the Power Unit by mistake.**

Connecting the Hydraulic Hose

One end of the Hydraulic Hose is already connected to the Hydraulic Cylinder; the other end of the Hydraulic Hose needs to be connected to the Power Unit.

To connect the Hydraulic Hose to the Power Unit:

1. Locate the Hydraulic Power Port on the Power Unit to be used and remove the Shipping Plug, then attach a 04 JIC – 06L ORB Hydraulic Fitting (5550008) to the Port.
See **Connecting the Power Source** for the possible Power Port connector locations. Usually labelled P1 or P2.
2. Apply a few drops of clean hydraulic fluid to the ORB Fitting O-ring to prevent damage.
3. Connect and securely tighten the ORB end of the Fitting to the Hydraulic Power Out on the Power Unit.
4. Connect and securely tighten the JIC end of the Fitting to the Hydraulic Hose. Do not over tighten.

Connecting the Power Source

The standard Power Unit for your Lift is 220 VAC, 60 Hz, single phase. The Power Unit must be connected to an appropriate power source.

Refer to **Wiring Diagrams** for wiring information.

⚠ DANGER All wiring **must** be performed by a licensed Electrician in accordance with local and national electrical codes. Do not perform any maintenance or installation on the Lift without first verifying that the electrical power has been disconnected from the Lift and **cannot** be re-energized until all procedures are complete. If your organization has Lockout/Tagout policies, make sure to implement them before and after connecting to a power source.

Important electrical information:

- Improper electrical installation can damage the motor; this is not covered under warranty.
- Use a separate circuit breaker for each Power Unit.
- Protect each circuit with a time-delay fuse or circuit breaker. For a 220 VAC, single phase circuit, use a circuit breaker or fuse appropriately rated for the Power Unit being installed.

The Hydraulic Power Ports are usually labeled **P1/P2** on the Power Unit; the Hydraulic Return Ports are commonly labeled **T1/T2** or **CV1/CV2**.

The following figure Displays the standard configuration for the Power Unit.

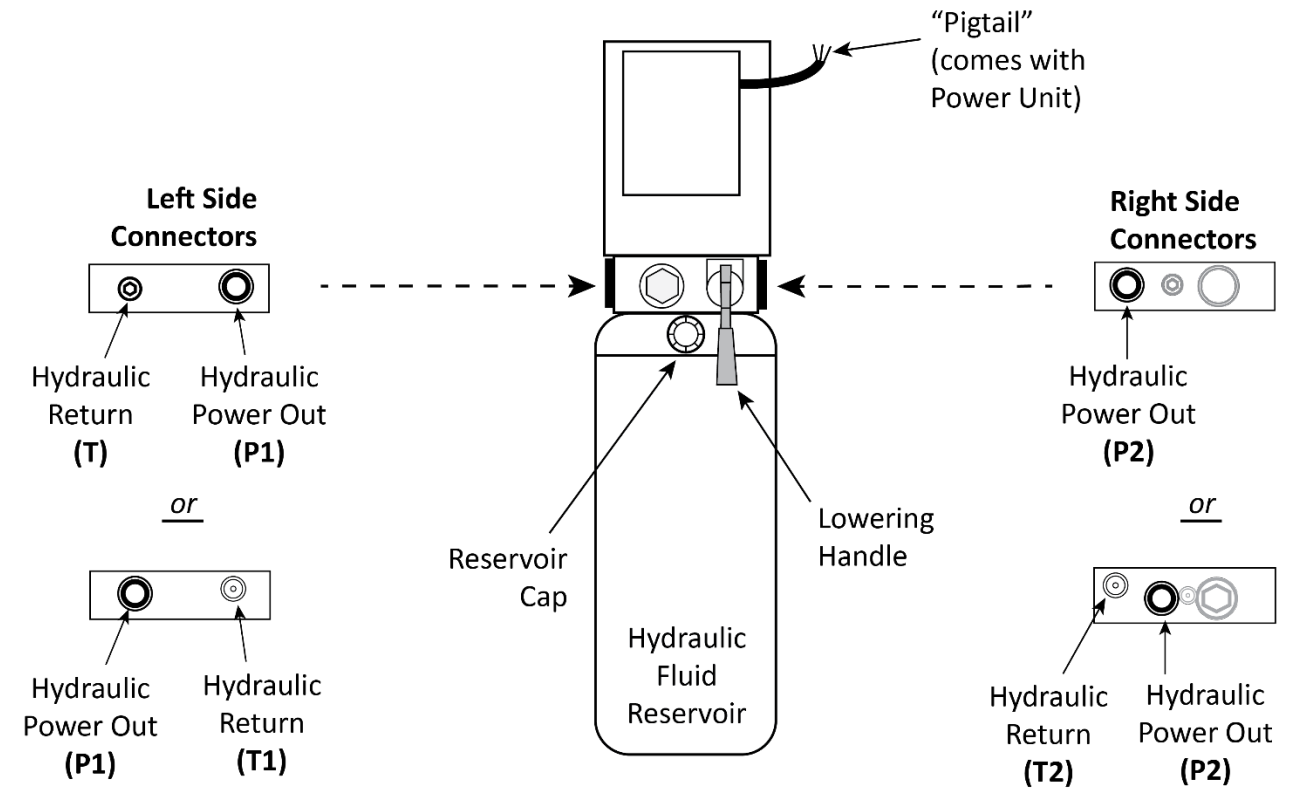

Not drawn to scale. Not all components shown.

To connect the Lift to a power source:

1. Have a licensed Electrician locate the Pigtail exiting the Electrical Junction Box on the Power Unit.
2. Open the Electrical Box, *remove* the Pigtail, and then either:
 - Wire the Power Unit directly into the facility’s electrical system and protect using an appropriate circuit breaker.
 - Wire a Power Cord (with appropriate plug) inside the Electrical Box to the wiring that was connected to the Pigtail.

Do not use the Pigtail.

NOTICE The Power Cord and Plug are **not** supplied with the Lift.

See **Wiring Diagrams** for wiring information.

3. Close the Electrical Junction Box.

Installing a Power Disconnect Switch

⚠ WARNING A main Power Disconnect Switch is **not** provided with this equipment.

A Power Disconnect Switch is a National Electrical Code (NEC) requirement. They are designed to interrupt electrical power in the event of an electrical circuit fault, emergency, or when equipment is undergoing service or maintenance.

BendPak strongly recommends that you install a Power Disconnect Switch that is properly rated for the incoming power.

⚠ DANGER All wiring **must** be performed by a licensed Electrician in accordance with national and local codes.

Your Power Disconnect Switch must be readily accessible and installed so that it is in easy reach of the Lift operator. It must be clearly and legibly marked to indicate its purpose.

The figure to the right shows a toggle Power Disconnect Switch between the Lift's power source and its Power Unit. A quick flip of the switch immediately cuts power to the Lift.

Make sure to have a licensed Electrician install the Power Disconnect Switch.

Make sure the electrician selects a **UL-listed** Power Disconnect Switch.

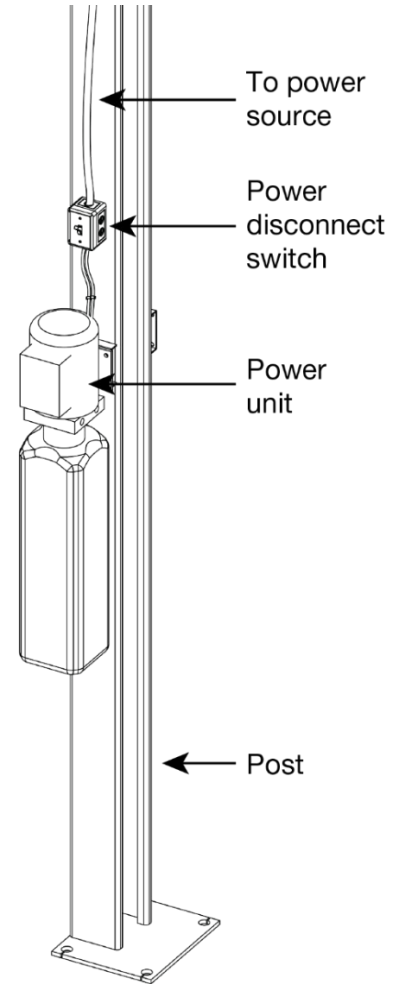

Installing a Thermal Disconnect Switch

The Power Unit supplied with this Lift **does not** include thermal overload protection. Under NEC 430, UL 201, and CSA C22.2 No. 68 intermittent duty motors are not required to include thermal protection. Local electrical codes may vary, and other requirements may exist that the installing electrician will address, if required.

⚠ DANGER If local Electrical codes require the installation of a Thermal Disconnect, the disconnecting device and the installation **must** be provided by a licensed Electrician in accordance with local electrical codes. Do not perform **any** maintenance or installation on the Lift without first verifying that main electrical power has been disconnected from the Lift and **cannot** be re-energized until all procedures are complete.

About Effective Embedment

Anchor Bolts (also called Wedge Anchors) obtain their holding strength from how far down into the Hole the Anchor Bolt's Expansion Sleeve presses into the Concrete (called Effective Embedment) and how forcefully the Expansion Sleeve presses into the Concrete (based on the width of the hole and how much Torque is applied).

The further down the Expansion Sleeve is in the hole, the greater the Effective Embedment and thus the greater the holding strength of the Anchor Bolt. The hole should be drilled the same width as the Anchor Bolt with no wobbling. The correct amount of Torque is a range; too little Torque and the Anchor Bolts hold with less strength, too much Torque and you could damage the Concrete and lessen the Anchor Bolt's holding strength.

Note: Some people confuse Effective Embedment with *Nominal* Embedment, which is how far down into the Hole the *bottom* of the Anchor Bolt is. The two are **not** the same; Nominal Embedment does not tell you anything about the holding strength of the Anchor Bolt.

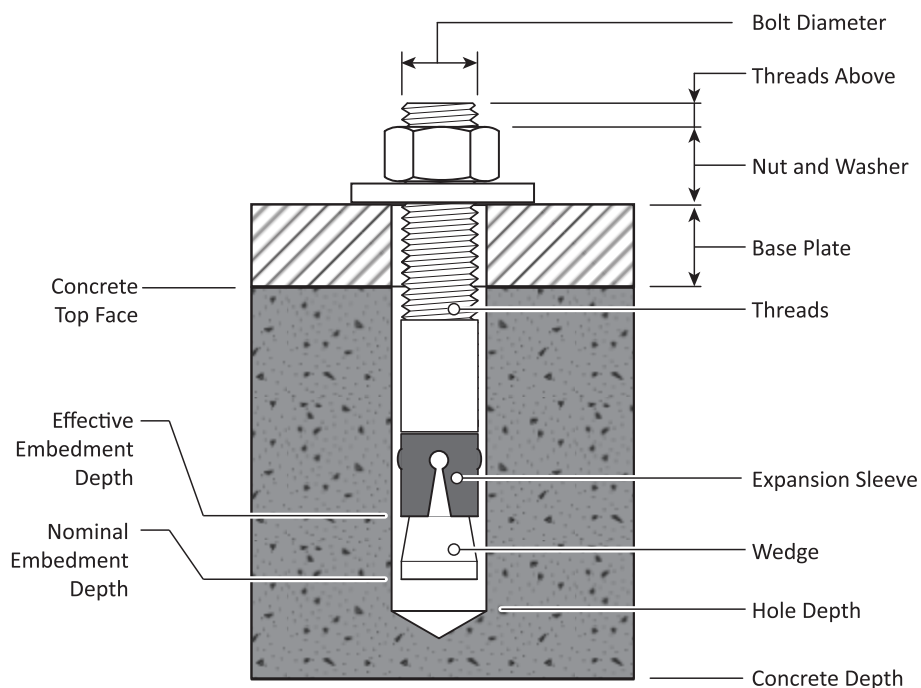

Make sure to carefully follow the specifications and instructions in the following procedure.

⚠ WARNING Use only the Anchor Bolts delivered with the Lift. Only install the Lift on a Concrete floor. Make sure to achieve the correct amount of Effective Embedment and use the correct amount of Torque.

Anchoring the Posts

Install one Anchor Bolt in each corner of each Base Plate, 4 per Post, 16 Anchor Bolts total.

Concrete specifications are:

- **Depth:** 4.25 in., (108 mm) min.
- **PSI:** 3,000 psi, (20.7 N/mm²) min.
- **Cured:** 28 days, minimum
- **Steel Reinforced**

Anchor Bolt specifications are:

- **Length:** 4.75 in. (121 mm)
- **Diameter:** .75 in. (19 mm)
- **Anchor torque:** 85-95 ft. lbs. (115-125 Nm)
(Torque no less than 80 or more than 95 ft. lbs.)

⚠ DANGER The Concrete and Anchor Bolts **must** meet these specifications. Only install the Lift on a Concrete surface. Installing a Lift on asphalt or any surface other than concrete, or using Concrete or Anchor Bolts that do not meet these specifications, can lead to product damage, Vehicle damage, severe injury, or even death.

BendPak Lifts are supplied with installation instructions and concrete fasteners meeting the criteria as prescribed by the American National Standard “Automotive Lifts – Safety Requirements for Construction, Testing, and Validation” ANSI/ALI ALCTV.

⚠ WARNING Use only the Anchor Bolts delivered with your Lift. If you use components from a different source, you void your warranty and compromise the safety of everyone who installs or operates the Lift.

Lift buyers are responsible for conforming to all regional, structural, and seismic anchoring requirements specified by any other agencies and/or codes, such as the Uniform Building Code and/or International Building Code.

To anchor the Posts:

1. Locate the hardware you will need: four Anchor Bolts, four Nuts, and four washers **per Post**.
2. Using the Base Plates as guides, drill the holes —one hole in each corner of the Base Plate, four holes total per Base Plate.

Important: Do **not** drill all the way through the concrete; if you punch completely through the slab, you compromise the holding strength of the Anchor Bolt once put into place.

Drill straight, in the center of the hole; do not let the drill wobble.

Use a carbide bit (conforming to ANSI B212.15).

The diameter of the drill bit must be the same as the diameter of the Anchor Bolt. If using a ¾ inch diameter Anchor Bolt, use a ¾" diameter drill bit.

3. Vacuum each hole clean.

⚠ CAUTION You must wear the proper safety gear for all drilling operations.

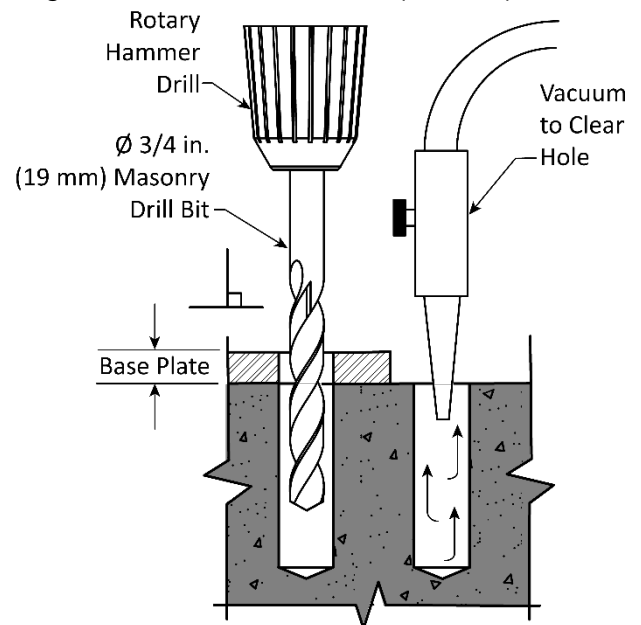

Important: The holding strength of an Anchor Bolt is partially based on the how cleanly the Expansion Sleeve presses against the Concrete. If the hole is dirty, the Expansion Sleeve will not press as cleanly, which means less holding strength. If the hole is too wide, the Expansion Sleeve will not press against the Concrete with as much force, again resulting in less holding strength.

4. Make sure the Washer and Nut are in place, **with the top of the Nut flush with the top of the Anchor Bolt**, then insert the Anchor Bolt into the hole.
5. Hammer or mallet the Anchor Bolt down into the hole.
6. Hammer or mallet the Anchor Bolt the rest of the way down into the hole. **Stop when the Washer is snug against the Base Plate.**
7. Plumb each Post; install any needed Shims.

Do not shim a Post more than half an inch using the provided Shims. A maximum of 2 in. (51 mm) is possible by ordering optional Shim Plates. Contact BendPak at **(800) 253-2363**, then follow the prompts to order. Please have the model and serial number of your Lift available.

Take your time while plumbing and shimming the Posts; **it is important to make the Lift level as possible.**

8. Wrench each Nut **clockwise** to the recommended installation torque, 85-95 ft. lb. (115-129 Nm), using a Torque Wrench.

Important: Do **not** use an impact wrench to torque the Anchor Bolts.

Wrenching the Nut forces the Wedge up, forcing out the Expansion Sleeve and pressing it tightly against the Concrete.

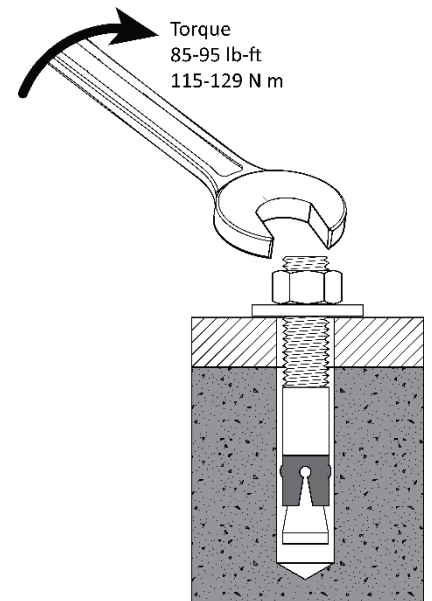
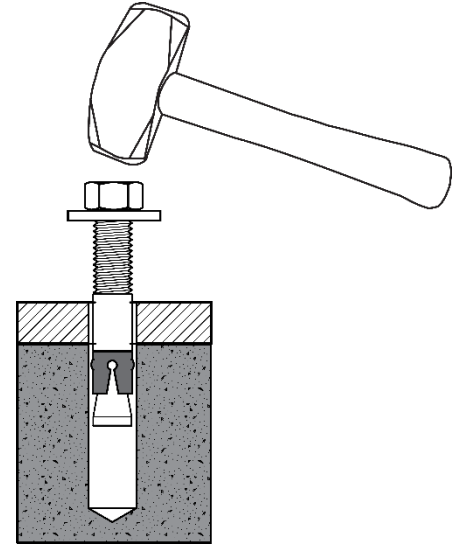

Final Leveling

The following procedure describes how to fine tune how level your Lift is. The goal is that the four Safety Locks engage at the same time.

To complete the final leveling on the Lift:

1. Raise the Runways up to at least the first Lock position (the primary Safety Locks, not the Slack Safety Locks).
2. Use a transit level or other leveling mechanism to evaluate how level the Posts and Runways are to each other.
3. If a Runway requires an adjustment for level, use the Top Nut and Stop Nut on the Top Cap of each Post to adjust the Safety Ladder in that Post. After leveling the Runways through the four Safety Ladders adjust the Lift Cables in the next step.
4. Use a step ladder to access the top of the Lift Post and adjust one Lift Cable. Observe the Crosstube position and slowly tighten the Lift Cable until the top of the Crosstube is even with the bottom edge of the Safety Ladder Window. Refer to the figure below.

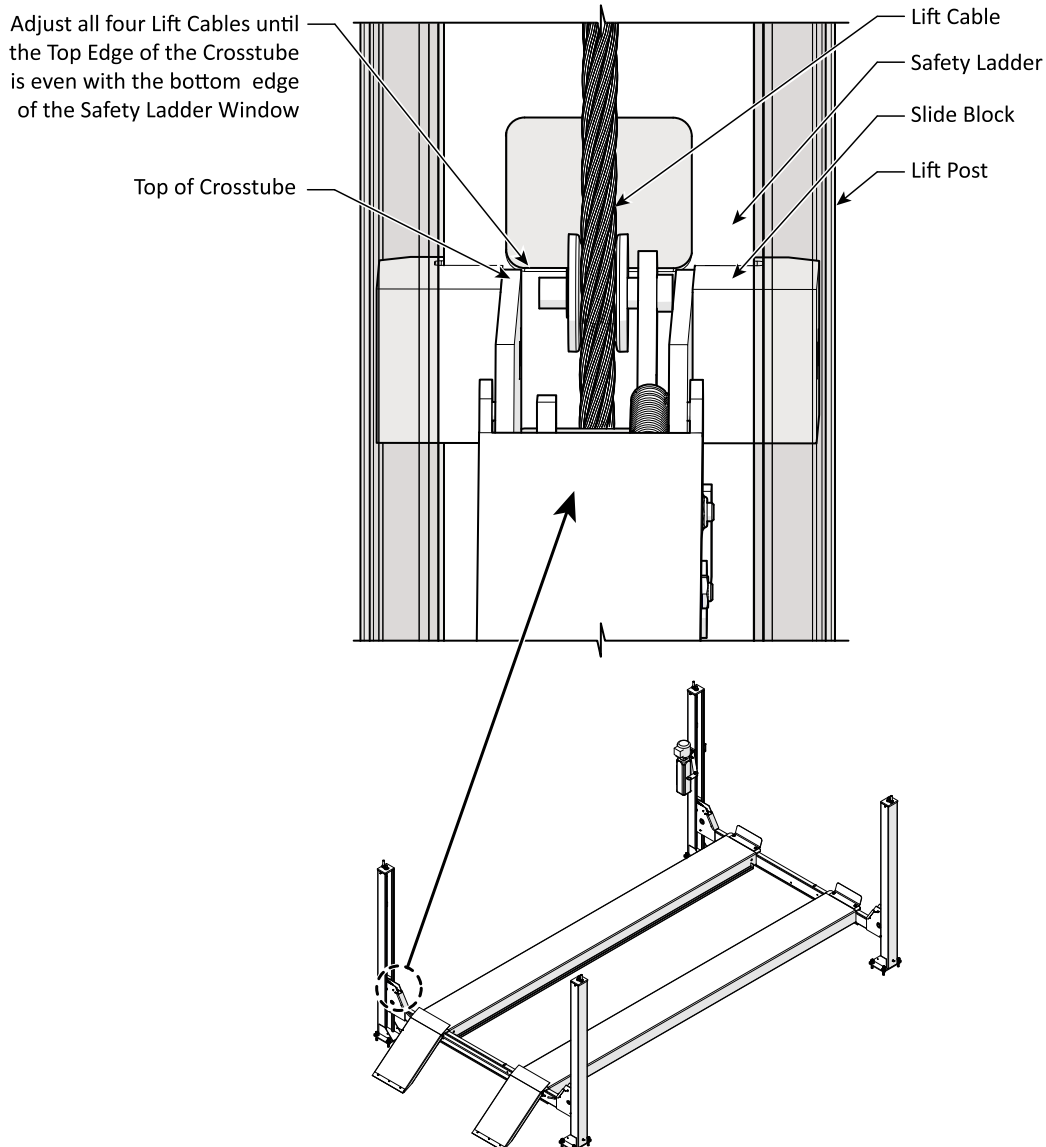

5. Repeat for the remaining Lift Cables. The top of all Crosstubes should now be even with the bottom of the Safety Ladder Window in each Lift Post. Do not stand on the Runways when adjusting the Lift Cables.

6. Raise the Lift to its maximum height, listening as the Safety Locks engage.

If the Safety Locks are engaging at the same time, no further adjustments are necessary.

If the Safety Locks are *not* engaging at the same time, adjust the Lift Cables, check the leveling, make necessary adjustments, and then lower and raise the Lift again and listen as the Safety Locks engage.

⚠ DANGER **Stop lowering immediately, if one corner of the runway is higher than the other three corners.** This condition indicates one Safety Lock has not disengaged while the operator has allowed the Lift to descend. Refer to **Troubleshooting**.

7. When satisfied the Lift is level, and the Locks are engaging at about the same time, **firmly secure the Safety Ladder Nut and Stop Nuts at the top of each Post**. Verify a minimum of about 1 in. (25 mm) of thread is visible above the Lift Cable Nut.

Installing Accessories

The accessories available for your HDS-14 Series Lift include:

Tire Stops

Tire Stops are installed at the Front of the Lift; they prevent the Tires of your Vehicle from moving too far forward.

To install the Tire Stops:

1. Find the two Tire Stops, four M14 x 40 Hex Head Bolts, M14 Washers, M14 Split-lock Washers, and M14 Nuts.
2. Put a Tire Stop in position over the front of the Runway, then secure in place with a Bolt, Washer, Split-Lock Washer, and Nut in each hole.

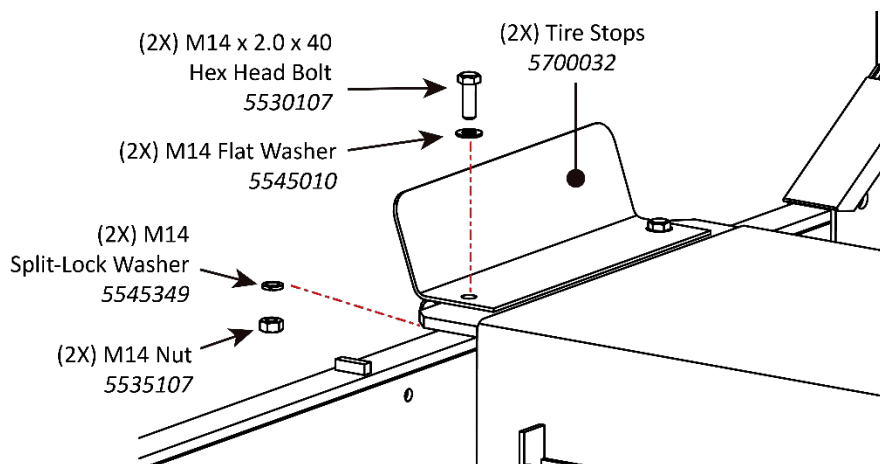

3. Repeat Steps 1 and 2 for the other Tire Stop.

Drive-up Ramps

The HDS-14 Series Lifts use Drive-up Ramps for Vehicles to be easily driven onto and off the Runways.

To install the Drive up Ramps:

1. Find the required components: two Ramps, two Ramp Pins, and four Rotor Clips.
2. Put a Ramp into position at the rear of the Runway, with the Ramp Tube aligned between the two tubes attached to the Runway.
3. Slide a Ramp Pin through the top Runways tubes, then put two Rotor Clips on both ends of the Ramp Pin.

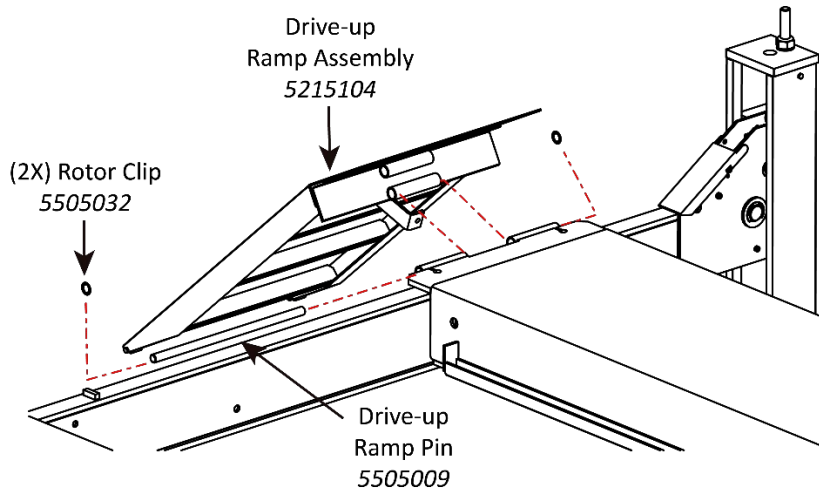

Note: The Ramps are heavy and awkward, consider having two people install them.

4. Repeat Steps 2 and 3 for the other Ramp.

Crosstube Covers

The HDS-14 Series Lifts use Crosstube Covers to protect the Gusset components.

To install the Crosstube Covers:

1. Find the four Crosstube Covers from the Parts Box.
2. Attach the Cover to the top of the Crosstube Gusset; do the same for the remaining Gussets.

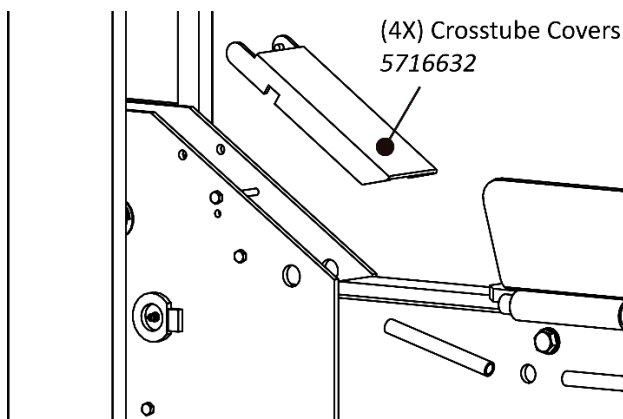

Applying Anti-Slip Tape

The Anti-Slip Tape (SKU 5930195) is provided in a single roll measuring 6 in. x 24 ft. (152 mm x 7.3 m). BendPak suggests cutting the Tape into four equal lengths 72 in. (1,829 mm) long each.

IMPORTANT! **Surface preparation is important. If the runway is in poor condition with gouges, holes, or jagged edges the Anti-Slip Tape will not adhere. Lift Runways must be clean, dry, and smooth.**

To apply the Anti-Slip Tape:

1. Clean the runway. Use a broom or brush to remove loose dirt and debris from the runway.
2. Thoroughly wash, rinse, and dry the runway using a mild solution of soap and clean water to remove any oils, grease, and water soluble contamination. Dry the runway with a clean cloth and allow to air dry.
3. Cut the Anti-Slip Tape into four equal pieces. Suggested length is 72 in. (1,829 mm).
4. Verify the Runway is dry and clean. It is critical for maximum adhesion of the Anti-Slip Tape that the runway be dry, free of dirt, oils, and grease.
5. Measure and mark the runways with pencil guide lines to outline the tape installation area on the ramp. Refer to the figure on the next page for a suggested layout of the Anti-Slip Tape.

IMPORTANT! Do not install this Tape directly on the edge of a Runway. Stay at least 1 in. (25 mm) away from edges. Do not attempt to bend this Tape over an edge.

6. Wash your hands. The Anti-Slip Tape's adhesive side is protected by a paper or plastic film. You will remove this film a few inches at a time to apply the Tape to the Runway.

IMPORTANT! Handle the tape by its edges. Minimize contact between the adhesive and your hands. The oils from your hands will reduce the adhesive's long-term effectiveness.

IMPORTANT! BendPak recommends two people work together to install the Tape. One person removes the backing and applies the Tape to the Runway while the second holds the Tape in place over the guide lines marked on the Runway.

7. Lay one piece of the Anti-Slip Tape on the runway and peel back about 2 in. (50 mm) of the protective film. Apply the adhesive side to the Runway inside the guide lines you created in step 5.
8. Slowly remove the film as you press the exposed Tape's adhesive side into the Runway. Work slowly and apply 2 to 5 in. (51 to 127 mm) at a time to stay within your guide lines.
9. After applying the Tape use a heavy rubber roller to press the Tape into the Runway and to ensure firm contact with the adhesive.
10. Apply the Anti-Slip Tape to the remaining area of the Lift's runways similar to the figure on the next page.

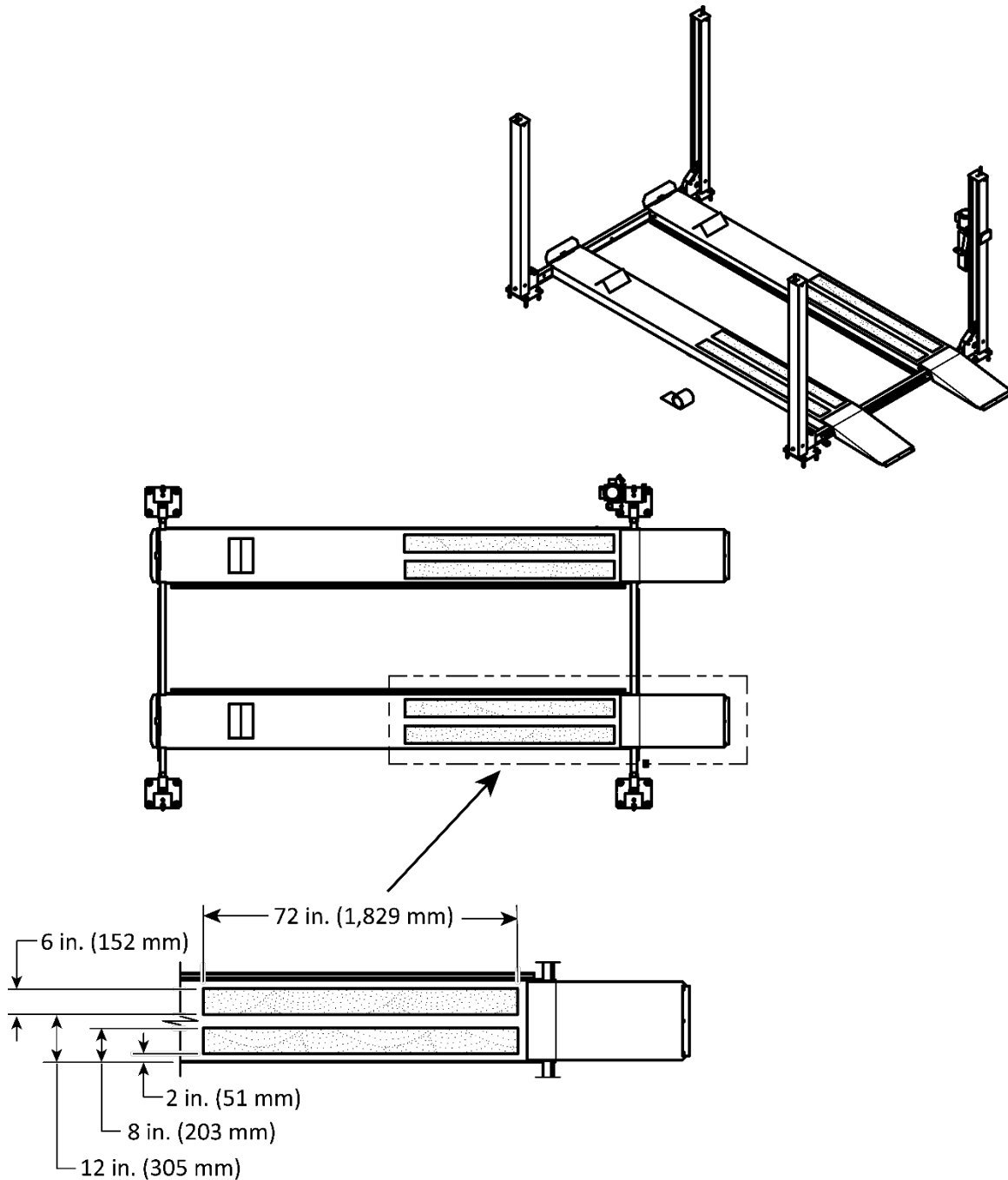

Technical support and service is available from your dealer, on the Web at bendpak.com/support, by email at support@bendpak.com, or by phone at **(800) 253-2363**, extension 196. You may also contact BendPak for parts replacement information (please have the model and serial number of your unit available) at **(800) 253-2363**, follow the prompts.

Bleeding the Hydraulic Cylinder

The Hydraulic Cylinder on the Lift is self-bleeding, which means that in most cases any air in the system can be removed by raising and lowering the Runways a few times.

Symptoms of air in the Hydraulic System include Runways moving erratically and/or making odd noises. These could be caused by other situations; refer to **Troubleshooting** for more information.

⚠ WARNING Before performing any maintenance on your Lift, make sure the Runways are fully lowered, and the power source has been completely disconnected. If your organization has Lockout/Tagout policies, make sure to implement them after connecting to the power source.

To bleed the Hydraulic System:

1. Raise and lower the Runways up to six times; **pause for at least one minute between each cycle.**

⚠ CAUTION The Lift's motor cannot run continuously; it is designed for regular use, but not continuous use.

2. Watch the Runways as they raise and lower. When the Lift stops moving erratically or stops squeaking, you can stop the process.
3. Check the Hydraulic Fluid Reservoir on the Power Unit.

Bleeding the Hydraulic System may significantly lower the amount of Hydraulic Fluid in the reservoir. Add more Hydraulic Fluid, if necessary.

If your Lift is still moving erratically or making odd noises after bleeding the Hydraulic System, refer to **Troubleshooting** for more information.

Lubrication

See **Lubrication Procedure** in the Maintenance Section

The sheave pins and bores should have already been lubricated with Red Lithium Grease.

Lightly Lubricate the inside of the Lift Posts where the Slide Blocks contact the Lift Post with White Lithium Grease. Refer to the figure below.

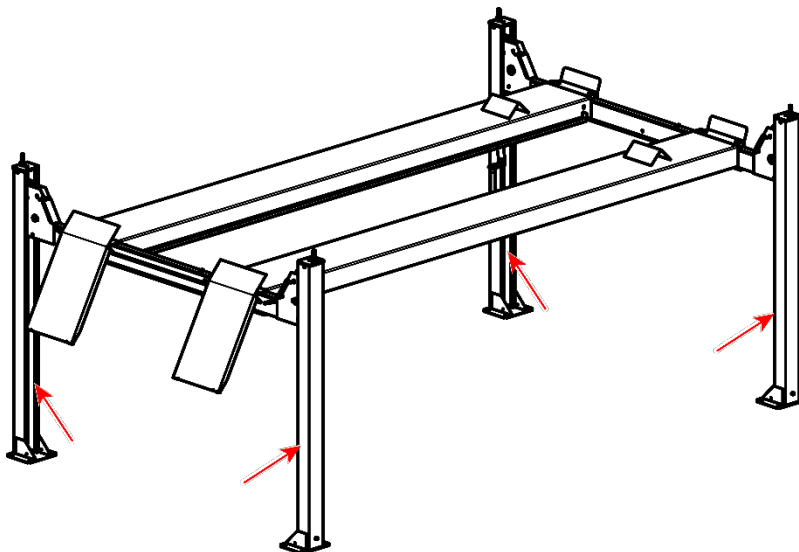

Perform an Operational Test



BendPak recommends performing an operational test of your Lift with a standard Vehicle on the Runways before starting normal service (a typical Vehicle is not required but is recommended).

NOTICE Residual air in the Hydraulic Systems can cause the Lift to shake, move erratically, or squeak when you start using it; this is normal. If it happens, do not worry; it will go away as the Hydraulic System is self-bleeding. If it does not go away soon, try bleeding the Cylinder of air. If it still does not go away, see **Troubleshooting** for more information.

To test your Lift:

1. Before beginning to use the Lift, verify there are no people, pets, or objects that might be in the path of the Lift as you raise and lower it.
 2. Carefully and slowly drive the Vehicle onto the Runways; try to center the Vehicle's Tires in the middle of each Runway.

Put the Vehicle into park, put on the parking brake, put it in gear if it is a manual transmission, and chock the wheels.
 3. Press and hold the **Up** button.

After the Runways pass three or four Safety Locks (you will hear them), release the **Up** button.
 4. Press and hold the pushbutton on the Pushbutton Air Valve, then press and hold the Lowering Handle.
-  **WARNING** Never leave the Lift without making sure that all four Safety Locks have engaged on locking positions at the same height. If one of the four Safety Locks do not fully engage, the Runways will not be level, and you could risk damaging any Vehicles sitting on or underneath the Runways.
5. Press the **Up** button for a few seconds to disengage the Runways from the Safety Locks, then release the **Up** button.
 6. Press and hold the Pushbutton Air Valve while simultaneously pressing and hold the Lowering Handle. When the Runways reach the ground, release the Lowering Handle. Wait for one minute.
-  **CAUTION** Always take a break between cycles. The Power Unit's motor is **not** constant duty; it cannot be run continuously.
7. Repeat the process, this time raising the Runways to a higher Safety Lock.
 8. If the Lift is working without shaking, moving erratically, or squeaking, there is no need to repeat the procedure.

If the Lift is shaking, moving erratically, or squeaking (which is normal during the start-up period), repeat the procedure a couple more times, with at least a one-minute break between cycles.
- If you continue to have issues, refer to **Troubleshooting** for assistance.

Final Checklist

Verify the following tasks have been done **before** putting the Lift into service:

- Review the **Installation Checklist** to make sure all steps have been performed.
- Make sure the Power Unit is receiving power from the power source.
- Check the Hydraulic Fluid Reservoir on the Power Unit; it must be full of approved Hydraulic Fluid or automatic transmission fluid. **You can damage the motor by running it without enough fluid.** Check the Hydraulic System for leaks. Check for any loose Hydraulic Fittings and Auxiliary Port Plugs. Inspect for pinched or damaged Hydraulic Hoses and replace them **before** operation.
- Verify all four Posts are properly anchored, shimmed, level, and stable.
- Verify all Lift Cables are properly seated in their Cable Sheaves.
- Verify all Safety Locks are operating normally. Make sure nothing is interfering with the Safety Locks.
- Make sure the backup Slack Safety Locks are **not** engaged.
- If it has not already been done, lubricate all Cable Sheave Pins and the Cable Sheave Bores with red lithium grease or similar.
- If it has not been done already, perform an Operational Test of the Lift with a typical Vehicle. Refer to **Test the Lift**.

Leave the Manual with the Owner/Operator

Make sure to leave the *Installation and Operation Manual* with the owner/operator so that it is available for anyone who needs to read it.



Operation

This section describes how to operate your Lift.

 **DANGER** When you even hear the words “automotive lift”, your brain should automatically remember that lifting a Vehicle is a serious endeavor with life-threatening risks. Focus on what you are doing. Automotive Lifts are dangerous tools when used by inexperienced or impaired operators. **Do not assume you are going to be safe this time because nothing happened last time.**

 **WARNING** Never walk or work under the lift until **all four safety locks are securely engaged.**

Safety Considerations

Do the following every time **before** raising a Vehicle on the Lift:

- **Check the Lift.** Walk all the way around the Lift, checking for any missing, heavily worn, or damaged parts. Always verify all Hydraulic connections including Hydraulic Fittings, Hydraulic Hoses, and Auxiliary Ports are secure. Do not operate the Lift if you find any issues; instead, take it out of service, then contact your dealer, email support@bendpak.com, or call **(800) 253-2363**, then follow the prompts.
- **Check the area.** Keep the area around and under the Lift clean and free of obstructions; anything that could cause a problem or interfere with driving a Vehicle onto or off the Lift. Do not forget to check **above** the Lift. If an obstruction is found, move it out of the way. If any other issues are found, resolve them before using the Lift. Do not allow any people or animals within 30 feet of the Lift while it is in motion.
- **Check the operators.** Make sure everyone who is going to operate the Lift has been trained in its use, has read the labels on the unit, and has read the manual. Only the operator at the Controls should be within 10 feet of the Lift when it is in motion.

Do not allow children to operate the Lift. Do not allow anyone under the influence of drugs, alcohol, or medication to operate the Lift. Do not allow any unauthorized personnel to operate the Lift.

- **Check for safety.** Make sure everyone who is going to be walking near the Lift is aware of its presence and takes appropriate safety measures. Only put Vehicles on the Runways.

When raising a Vehicle, do not leave it until the Platform is engaged on a Safety Lock. When lowering the Lift, do not leave it until it is on the ground.

- **Check the Vehicle.** Never exceed the Lift’s weight rating. Do not allow people inside a Vehicle you are going to raise. Double check everything needed is out of the Vehicle before raising the Lift. Make sure the Vehicle is not overbalanced on either end or either side.

Using the Controls

The Controls for the HDS-14 Series Lift include:

- **Up button.** Press and hold to raise the Runways. Located near the top of the Power Unit.

To put Runways onto a Safety Lock position: Raise the Runways a little above the desired height, then press and hold the Lowering Handle to back the Runways down onto the nearest Safety Lock position (do not press and hold the pushbutton on the Pushbutton Air Valve). When the Runways stop moving down, they are engaged on a Safety Lock.

Before leaving the Lift, verify all four corners are engaged on their Safety Locks.

- **Lowering Handle.** Press and hold to lower the Runways. Found near the middle of the Power Unit.

To lower raised Runways down to the ground: press and hold the Pushbutton on the Pushbutton Air Valve first, then **press and hold** the Lowering Handle.

Watch the Runways as they go down to make sure they are coming down evenly. If they are not, stop lowering the Lift and troubleshoot the problem.

⚠ WARNING: Never walk or work under the Lift until all four Safety Locks are securely engaged. If any of the Safety Locks cannot be engaged, lower the Lift to the ground and arrange for repair.

⚠ WARNING: Never leave the Lift until all Safety Locks are securely engaged or it has been lowered to the ground.

- **Pushbutton Air Valve.** Press and hold the Pushbutton on the Pushbutton Air Valve as part of the process to lower the Runways. Located on one side or the other of the Power Unit (depending on where it was installed). Pressing and holding the Pushbutton Air Valve disengages the Safety Locks to lower the Runways.

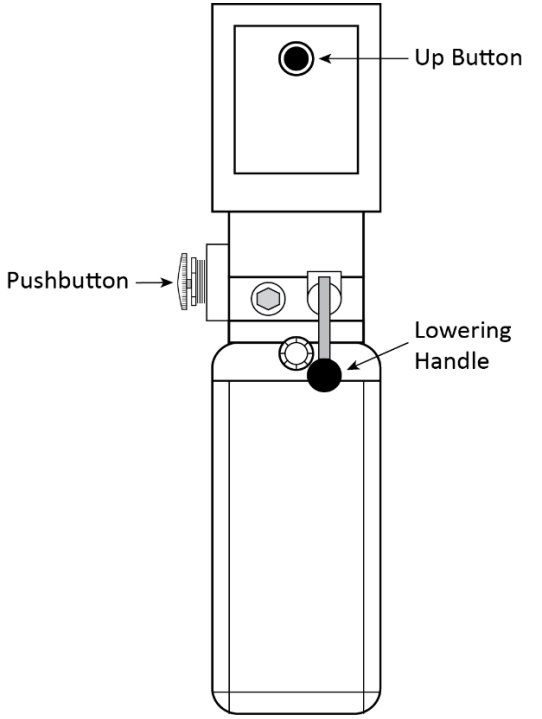
<p>To raise Runways to a Safety Lock:</p> <ol style="list-style-type: none"> 1. Press and hold Up Button. 2. When just past desired height, release Up Button. 3. Press and hold Lowering Handle. 4. Runways stop moving down when engaged on a Safety Lock; release the Lowering Handle when they stop. <p><i>Do not press and hold the Pushbutton Air Valve.</i></p>	 <p>The diagram shows a vertical control panel. At the top is a circular 'Up Button'. Below it is a 'Pushbutton' on the left side. At the bottom is a 'Lowering Handle' in the center. Arrows point from the text labels to their respective components in the diagram.</p>	<p>To lower Runways:</p> <ol style="list-style-type: none"> 1. Press the Up Button for a second or two. This disengages the Runways from the Safety Locks. 2. Press and hold Pushbutton <i>and</i> Lowering Handle <i>at the same time.</i> Runways begin lowering. 3. When Runways are fully lowered, release Pushbutton and Lowering Handle. 4. Drive Vehicle off Runways.
---	---	---

Raising and Lowering Vehicles

Keep the following in mind when operating your Lift:

- **Be safe.** Make sure to check for people, pets, and objects that might be in the path of the Lift as you raise or lower it. If there is something in the way, stop the Lift and move it out of the way. Watch the Lift carefully as it raises and lowers.

 **DANGER** Pay careful attention when you are raising or lowering your Lift. If a person or pet gets stuck under the Lift, they could be injured or, in rare cases, killed.

- **The Power Disconnect Switch exists for a reason.** We hope you never have to use it, but if something unexpected happens, use the **Power Disconnect Switch** to immediately stop the Lift from moving.
- **Get what you need out of the Vehicle before lifting it.** It is frustrating to raise a Vehicle and then realize you left something inside. **Never raise your Lift with people in the Vehicle.**
- **Make sure the Vehicle is balanced.** If there is extra weight on one end or the other, remove it or balance it before raising the Vehicle.
- **Center the Vehicle's wheels on the Runway.** Centered wheels keep the Vehicle balanced.

To raise a Vehicle:

1. Verify the Runways are on the ground. If they are not, lower them to the ground.
2. Carefully drive the Vehicle onto the Runways. Put the Vehicle into park and put on the parking brake.

If your Vehicle has a manual transmission, place the transmission in first gear, not in neutral.

3. Chock the Tires.
4. Walk around the Lift to make sure no obstructions will interfere with the Vehicle being lifted.
5. Press and hold the **Up** button.
6. When the Runways get to the desired locking position, go up a little bit more, then release the **Up** button and **Press and hold** the Lowering Handle.

 **WARNING** Only leave your Lift either engaged on Safety Locks or fully lowered.

7. With the Runways engaged on the Safety Locks, check around the Vehicle to make sure everything looks good.

If you see anything wrong, fix it before anyone gets near the Runways or goes under them.



To lower a Vehicle:

⚠ DANGER **Pay close attention while lowering the Lift! Verify all four corners are descending evenly!** If one corner remains on its Safety Lock while the other three corners descend, stop lowering immediately and raise the Lift Platforms to return the runways to the Safety Lock where all the Locks are engaged. Refer to the **Troubleshooting Section**.

⚠ DANGER **Crushing hazard and pinch points.** Do not place any part of your body between the top platform and any moving part of the Lift unless visual confirmation is made that the safety locks are fully engaged.

1. Double check that no one except the Lift operator is within 10 feet of the Lift.
2. Press the **Up** button to disengage the Runways from the Safety Locks.
After a second or two, release the **Up** button.
3. Press and hold the Pushbutton Air Valve **and** the Lowering Handle *at the same time*.
4. If all four corners of the Lift are descending evenly, bring the Runways all the way to the ground then release the Pushbutton Air Valve and the Lowering Handle.
5. Remove the Tire Chocks, then carefully drive the Vehicle off the Runways.



Maintenance

-  **DANGER** Before performing any maintenance on your HDS-14 Lift, verify it is completely disconnected from power. The Lift uses electrical energy; if your organization has Lockout/Tagout policies, make sure to implement them before performing any maintenance. Contact with high voltage can cause severe injury or death.
-  **DANGER** **Crushing hazard and pinch points.** Do not place any part of your body between the top deck and any moving part of the Lift unless visual confirmation is made that the safety lock is fully engaged, and that the Lift's downward motion is blocked by a Jack Stand, Forklift or other Load-Holding device that will prevent the Lift's downward movement while working under it.
-  **DANGER** Always refer to the lubricant and hydraulic fluid manufacturer's Material Safety Data Sheet (MSDS) for proper handling and disposal of chemicals.

Important: Unless stated otherwise, all Lift maintenance may be carried out by the owner/employee and does not require trained Lift personnel.

Read your manual and understand how this equipment works before using, maintaining or repairing. Routine maintenance and adjustments are the responsibility of the owner/user and are not covered under warranty. Routine maintenance and adjustments should be carried out on a regular basis. *Unless stated otherwise, all maintenance may be performed by the owner/employer and does not require trained lift service personnel.* Replace worn, damaged or broken parts with original BendPak or BendPak approved parts or with parts that meet or exceed the original specifications.

To maintain your Lift:

- **Daily:** Keep the HDS-14 Lift clean. Wipe up any spills, clean any dirt.
-  **WARNING:** Work with care. The Lift is slippery when wet or icy.
- **Daily:** Make a visual inspection of all moving parts and check for damage or excessive wear. Replace any damaged or worn parts before using the Lift.
-  **DANGER** Do not use the Lift if the Cables are damaged or extremely worn. If a Vehicle is raised when you notice the damage or extreme wear, very carefully lower the Vehicle to the ground. When the Lift is on the ground, take it out of service, disconnect it from power, and make arrangements to fix the damage or wear. Service and maintain the unit only with factory-approved replacements parts.
- **Daily:** Make sure all Safety Locks are in good operating condition. Do not use your Lift if the Safety Locks are damaged or excessively worn.
- **Monthly:** Check all labels on the Lift. Replace them if they are illegible or missing.
- **Monthly:** Grease all lubrication points on the Lift. Refer to the Lubrication procedure that follows this section.
- **Monthly:** Check Hydraulic Fluid levels. Refill if low.
- **Monthly:** Lubricate the wire rope (Cables). Use a wire-rope lubricant such as 90-WT gear oil or ALMASOL® Wire Rope Lubricant.
- **Monthly:** Check cable connections, bolts, and pins for proper mounting and torque.
- **Monthly:** Check Cable Adjustment as per the Cable adjustment procedure found in this section.

- **Every two months:** Check all Anchor Bolts to verify they are properly torqued. If they are loose, tighten them.
- **As required.** Take the Lift out of service and then replace the Lifting Cables if there are signs of damage or extreme wear. See **HDS-14 Wire Rope Inspection and Maintenance**.
- If the Lift becomes inoperative in a raised position, see the **Troubleshooting** section.

⚠ WARNING Do not operate your Lift if you find maintenance issues; instead, take the Lift out of service, then contact your dealer, visit [bendpak.com/support](https://www.bendpak.com/support), email support@bendpak.com, or call **(800) 253-2363**, then follow the prompts.

Lubrication Procedure

⚠ DANGER Always refer to the lubricant and hydraulic fluid manufacturer's Material Safety Data Sheet (MSDS) for proper handling and disposal of chemicals.

To Lubricate the Inside of the Lift Posts:

1. Verify all personnel are clear of the Lift area and no obstructions will interfere with the Lift platforms.
2. Lower the Lift Ramps to the Ground.
3. Spray the inside of the Lift Posts with White Lithium Grease.
4. Raise the Lift to its maximum height and lower again to distribute the lubricant evenly.

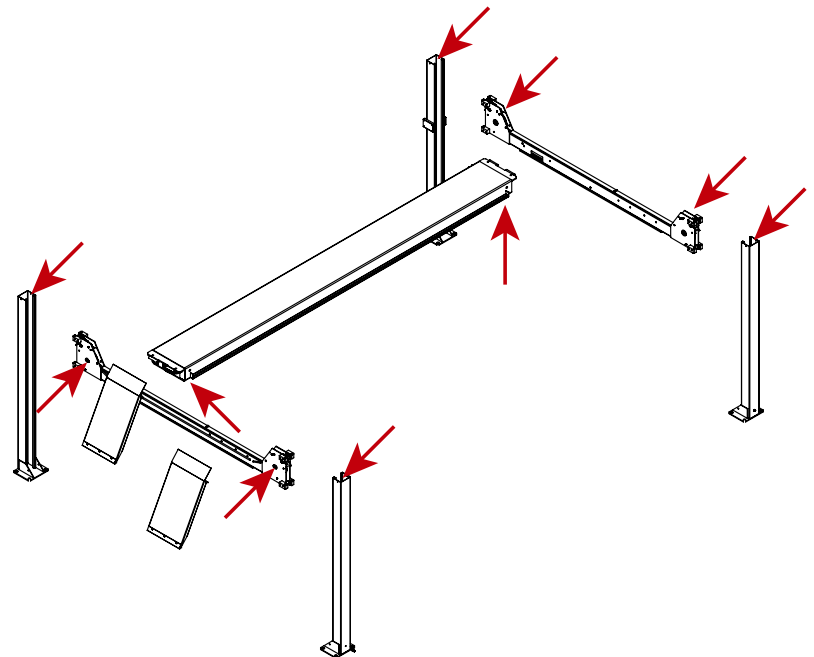

To Lubricate the Sheaves:

1. Verify all personnel are clear of the Lift area and no obstructions will interfere with the Lift Runways' motion.
2. Raise the Lift to its maximum rise and press the lower lever to bring the platforms to rest on the Top Lock.
3. Continue to press the lower lever until a bit of slack appears in the Lift Cables.
4. Lock out power to the Lift to prevent anyone from attempting to operate the Lift while maintenance is underway.

5. Remove each Sheave Pin and apply red lithium grease to the Sheave Bore and the Pin.
6. Reassemble the Pin into the Sheave and secure.
7. Repeat for every Sheave.

To Lubricate the Wire Rope:

See [Wire Rope Inspection and Maintenance](#).

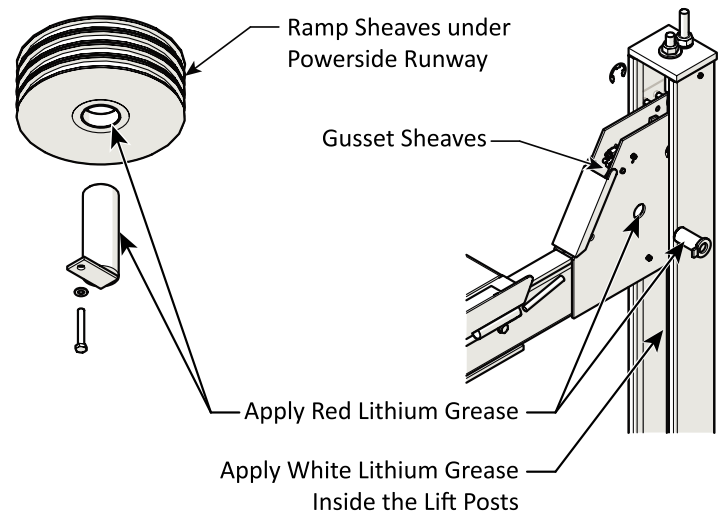

Lift Cable Adjustment Procedure

All Lift Cables will stretch over time. Longer Cables will stretch more than shorter Cables. This procedure is designed to adjust the Safety Lock engagement and disengagement to compensate for this effect. **Tools Required:** Step Ladder, Level, and Open End Wrenches.

⚠ WARNING You **must** wear OSHA-approved (publication 3151) personal protective equipment at all times when maintaining, or repairing the Lift: leather gloves, steel-toed work boots, eye protection, back belts, and hearing protection are **mandatory**.

1. Verify the Crosstubes are resting on the same Safety Lock measured from the bottom on all four Lift Posts.
2. Use a level to verify the Runways are flat before attempting to adjust the Cables.
 - a. If a Runway requires adjustment, use a wrench to loosen the stop nut under the Top Cap. Adjust the Safety Ladder up and down using the Safety Ladder Adjustment nut on top of the Lift Post as required to achieve a level Runway.
 - b. Once level, tighten the Stop Nut under the Top Cap and verify the Safety Ladder Adjust Nut is snug against the Top Cap as well.
3. Verify the threaded Lift Cable End is secured to the Top Cap on each Lift Post.
4. Verify *all four Cables* are under *slight* tension, no slack should be present anywhere in the system.
5. Use a Step Ladder to access the top of one Lift Post. **Do not stand on the Runway** while adjusting the Lift Cables.

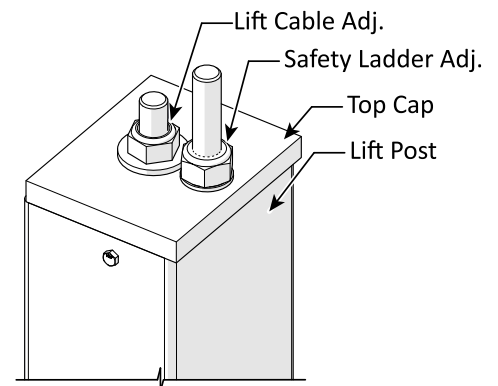

6. Adjust *all four Cables* until the top of the Crosstube is even with the bottom of the Safety Ladder Window on each Lift Post. Refer to the figure on the below.
7. Raise and then lower the Lift Platforms while observing all four corners to verify the Lift is descending evenly. If one corner is **not** descending, stop the Lift and refer to **Troubleshooting**.

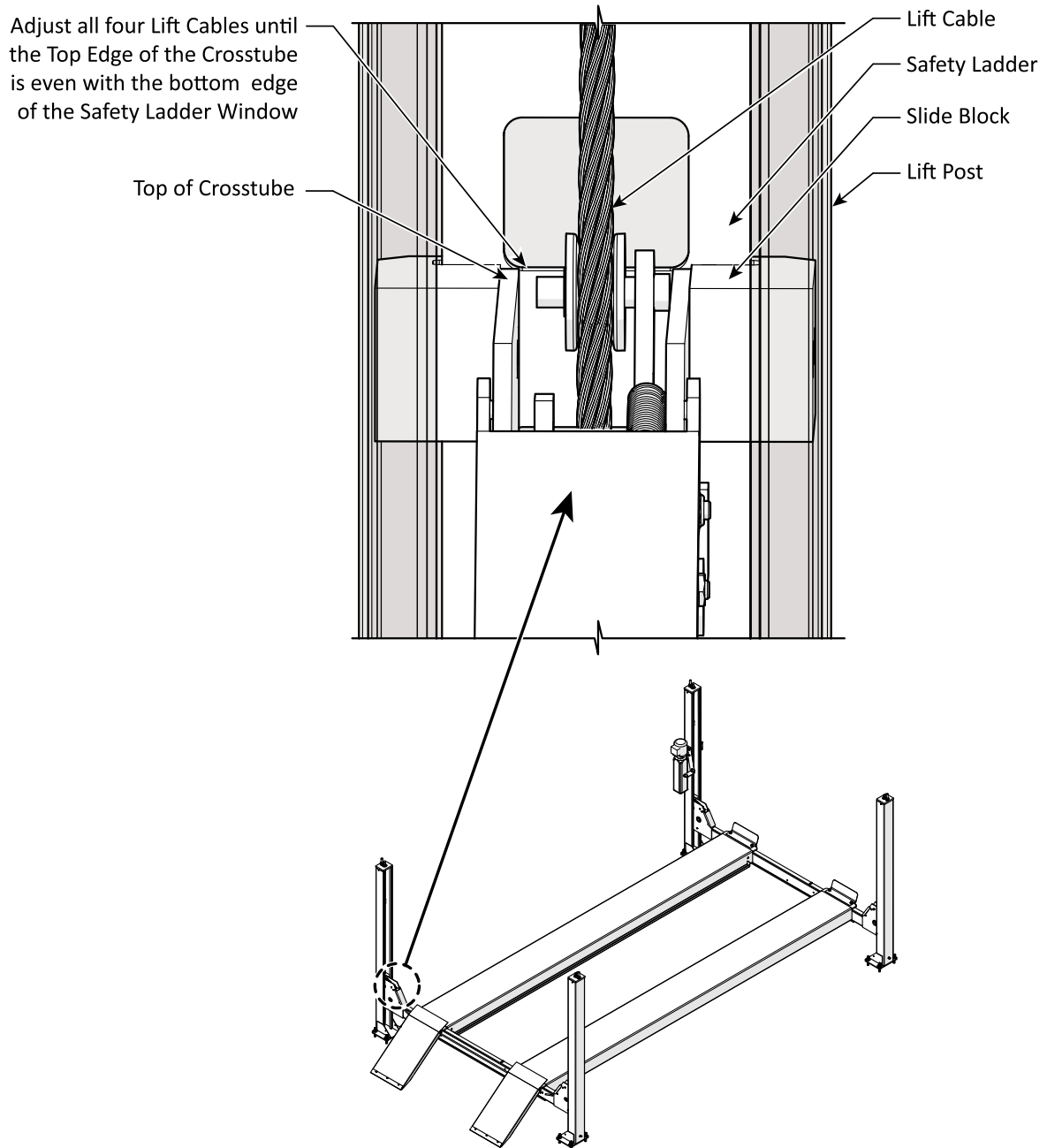

HDS-14 Wire Rope Inspection and Maintenance

Your Lift's Cables, which are a wire rope, should be inspected regularly:

- Wire rope should be replaced when there are visible signs of damage or extreme wear. *Do not use the Lift if it has damaged or worn Cables; **take it out of service!***

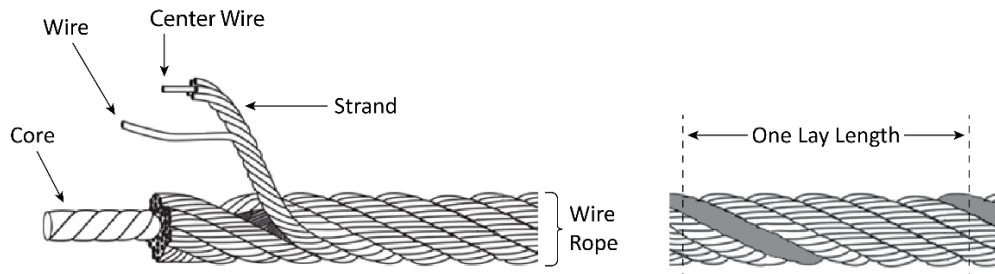

- Wire rope should be always maintained in a well-lubricated condition.

Wire rope is only fully protected when each wire strand is lubricated both internally and externally. Excessive wear shortens the life of wire rope. Use a wire-rope lubricant that penetrates to the core of the rope and provides long-term lubrication between each individual strand, such as 90-WT gear oil or ALMASOL® Wire Rope Lubricant. To make sure that the inner layers of the rope remain well lubricated, lubrication should be done at least every three months during normal operation.

- All Sheaves and guide rollers that contact moving wire rope should be given regular visual checks for surface wear and lubricated to make sure they run freely. This should be done every three months during normal operation.

For all sheave axles, use standard wheel bearing grease. For all Sheaves and/or guide rollers, use 90-WT gear oil or a similar heavy lubricant, applied by any method including pump/spray dispensing, brush, hand, or swabbing.

- How often should you inspect?

Wire rope should be visually inspected at least once each day when in use, as suggested by American Petroleum Institute's Recommended Practice 54 guidelines. Any wire rope that meets the criteria for removal must be immediately replaced.

- When should you replace wire rope due to broken wires?

Wire rope should be removed from service if you see six randomly distributed broken wires within any one lay length (where a single strand makes a full turn around the rope) or three broken wires in one strand within one lay length.







- Are there other reasons to replace your wire rope?

Yes. Corrosion that pits the wires and/or connectors, evidence of kinking, crushing, cutting, bird-caging, or a popped core, wear that exceeds 10% of a wire's original diameter, or heat damage.

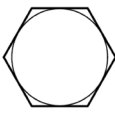
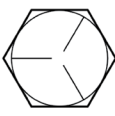
- How do you find broken wires?

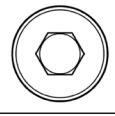
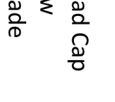
- a. Relax your rope to a stationary position and move the pick-up points off the Sheaves. Clean the surface of the rope with a cloth — a wire brush, if necessary — so you can see any breaks.
- b. Flex the rope to expose any broken wires hidden in the valleys between the strands.
- c. Visually check for any broken wires. One way to check for crown breaks is to run a cloth along the rope to check for possible snags.
- d. With an awl, probe between wires and strands and raise any wires that appear loose.

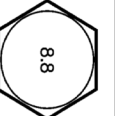
Fastener Torque

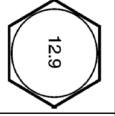
FASTENER TORQUE CHART													
Bolt Size (SAE)	Bolt Size (Metric)	Tightening Torque			Tightening Torque			Tightening Torque			Tightening Torque		
		Lubricated (ft-lbs)	Zinc Plated (ft-lbs)	Plain & Dry (ft-lbs)	Lubricated (ft-lbs)	Zinc Plated (ft-lbs)	Plain & Dry (ft-lbs)	Lubricated (ft-lbs)	Zinc Plated (ft-lbs)	Plain & Dry (ft-lbs)	Lubricated (ft-lbs)	Zinc Plated (ft-lbs)	Plain & Dry (ft-lbs)
	Bolt Grade (SAE)		SAE Grade 0-1-2		SAE Grade 5		SAE Grade 8		Socket Head Cap Screw		SAE Grade		
	Bolt Class (Metric)		Metric Class 4.6		Metric Class 8.8		Metric Class 10.9		Metric Class 12.9				
1/4-20	M6 x1.0	2.3	2.6	3.0	5.8	6.6	7.7	8.3	9.4	11.1	9.7	11.0	13.0
5/16-18	M8 x 1.25	3.8	4.3	5.0	9.7	11.0	13.0	13.9	15.8	18.5	16.3	18.4	21.7
3/8-16	M10 x 1.50	10.8	12.3	14.4	27.9	31.6	37.2	39.9	45.2	53.2	46.7	52.9	62.2
7/16-14	N/A	24.0	27	30.0	35.0	42	50.0	55.0	59	70.0	61.0	68	76.0
1/2-13	M12 x 1.75	18.9	21.4	25.2	48.7	55.1	64.9	69.6	78.9	92.8	81.4	92.2	108.5
9/16-12	M14 x 2.00	30.2	34.2	40.2	77.8	88.1	103.7	111.3	126.1	148.4	130.0	147.4	173.4
5/8-11	M16 x 2.00	47	53	62	121	137	161	173	196	230	202	229	269
3/4-10	M18 x 2.50	65	73	86	167	189	222	239	270	318	279	316	372
7/8-9	M22 x 2.50	136	155	182	320	365	430	460	515	600	510	575	640

WARNING! Prior to installation, inspect all accompanying manuals, parts lists and catalogs to ensure you have all the necessary parts. Identify all fasteners and their proper torque settings as illustrated on this chart. Proper torquing practices cannot be over emphasized. Torque values are provided as a convenient method of achieving correct pre-loading of highly stressed fasteners. If the fasteners are not properly plated, the fastener threads are not clean and free of deformation, or are not properly lubricated, the correct fastener pre-load will not be achieved even though the given torque value is reached. For this reason, it is critical that all fasteners be inspected for proper plating, thread form and correct lubrication prior to torquing. Failure to verify a fastener's serviceability or to correctly lubricate the fastener prior to assembly and torquing will result in the fastener not being properly pre-loaded and subsequent failure of the fastener may occur. The torque values can only be achieved if the nut (or tapped hole) has a proof load greater than or equal to the bolt's minimum ultimate tensile strength. Clamp loads estimated as 75% of proof load for specified bolts. Torque values are listed in foot-pounds. Torque wrenches should be calibrated on an annual basis. Never use an impact driver on a torque multiplier.

Lift and Hydraulic Fluid Disposal - End of Service Life

Once your Lift has reached the end of its service life it must be disposed of properly. Metal recyclers will be able to advise on methods and costs to remove the Lift and will *reuse* the materials, diverting them from landfills. The best option is to contact a metal recycling center and discuss the size and weight of the Lift to determine if the facility can deconstruct and recover the usable components and metals.

The Hydraulic Fluid, Cylinders, Hoses, Fittings, and the Power Unit itself must be disposed of in accordance with current national, state, and local regulations governing the use and disposal of hazardous materials. These components and any used Hydraulic Fluid **must not** be disposed of by dropping it into the trash or dumping it into the street. The Hydraulic Fluid contains toxic ingredients that are harmful to the environment.

These components and the Hydraulic Fluid are required to be recycled or must be delivered to a hazardous waste collection facility.

If you have large amounts of Hydraulic Fluid, consider contacting a commercial waste disposal company. In all cases, the best approach is to find an appropriate facility and contact them — in advance — to ask them: what kinds of fluids and materials they accept, what kind of containers it must be in, what hours they are open, their location, and any other information specific to their facility.

If you are unable to find an appropriate facility, the website [earth911.com](https://www.earth911.com) has resources that may be of help.

Troubleshooting

This section describes how to troubleshoot your Lift.

NOTICE If your Lift is not functioning correctly, you must take it out of service until it is fixed.

Important: Replace worn, damaged or broken parts with original BendPak or BendPak approved parts or with parts that meet or exceed the original manufacturer specifications.

⚠ DANGER Before performing troubleshooting on your Lift, verify it is disconnected from power. The Lift uses electrical energy; if your organization has Lockout/Tagout policies, implement them before performing any maintenance. If you come into contact with high voltage, you could be injured or killed.

Lift becomes inoperative in a raised position.	Verify there is sufficient Hydraulic Fluid in the reservoir. Verify the Lift Carriages are above and clear of the Safety Locks. Verify none of the Hydraulic Hoses are pinched or leaking. Verify the Power Unit is getting power. Make sure the Lift is not overloaded. Make sure the load on the Lift is balanced. Contact bendpak.com/support or by phone at (800) 253-2363 , then follow the prompts.
Runways do not lower past the nearest Safety Lock even when pressing and holding the pushbutton.	Problem with the Air Lines; check to make sure all sections of the Air Line are connected and not leaking.
Runways move erratically or squeak when in use.	Move the Runways up and down a few times to flush any residual air from the Hydraulic System. Make sure to pause for at least 2 minutes between cycles.
Runways do not stay up.	Check for leaking Hydraulic Fluid. Make sure the Runways are left on their Safety Locks.
Motor not running.	Check the connection to the power source; make sure it is plugged in and of the appropriate voltage. Check the wiring diagram.
Hydraulic Fluid is dirty.	Replace the dirty fluid with clean, approved Hydraulic Fluid.
Runways make odd noises.	Lubricate the Bushings on the Sheaves on the sides of the Crosstubes using white lithium grease. If the Lift is new, a break-in period may be needed; run the Lift several times each day. If the noises persist, contact BendPak Support.
One corner of a Platform is lower than the other three corners.	The Safety Lock on the lower corner is not engaged. Raise the Runways up, then lower them down onto the Safety Locks. Inspect to verify all four Safety Locks are engaged on Safety Locks at the same height.
One corner of a Platform is higher than the other three corners.	One Safety Lock has not disengaged.

One Corner of the Runway is higher than the other three corners.

⚠ DANGER **Stop lowering immediately! Clear the area of personnel!** This condition indicates one Safety Lock has not disengaged while the operator has allowed the Lift to descend.

1. Place the Lift into a safe condition by raising the Lift until all four corners are equal.
2. Once all four corners are equal, attempt to lower the Lift until it rests on the closest Safety Lock. This puts the Lift into a safe condition with all 4 Crosstube ends on their Safety Locks.

3. If the Lift cannot be put into a safe condition, then contact BendPak support, go to bendpak.com/support, email support@bendpak.com, or call **(800) 253-2363**, then follow the prompts.
4. Once the Lift is in a safe condition, inspect to verify no damage has occurred. It is critical to inspect the inner rails of the Lift Post. If any significant bending or distortion to the formed rails has occurred, then the Lift Post(s) may need to be replaced.

The figure below describes the forces and damage that can be expected if the operator allows one Safety Lock to remain engaged while the other three are allowed to descend. **Failure to operate or maintain the Lift properly can lead to damage of the columns as illustrated in the figure below.**

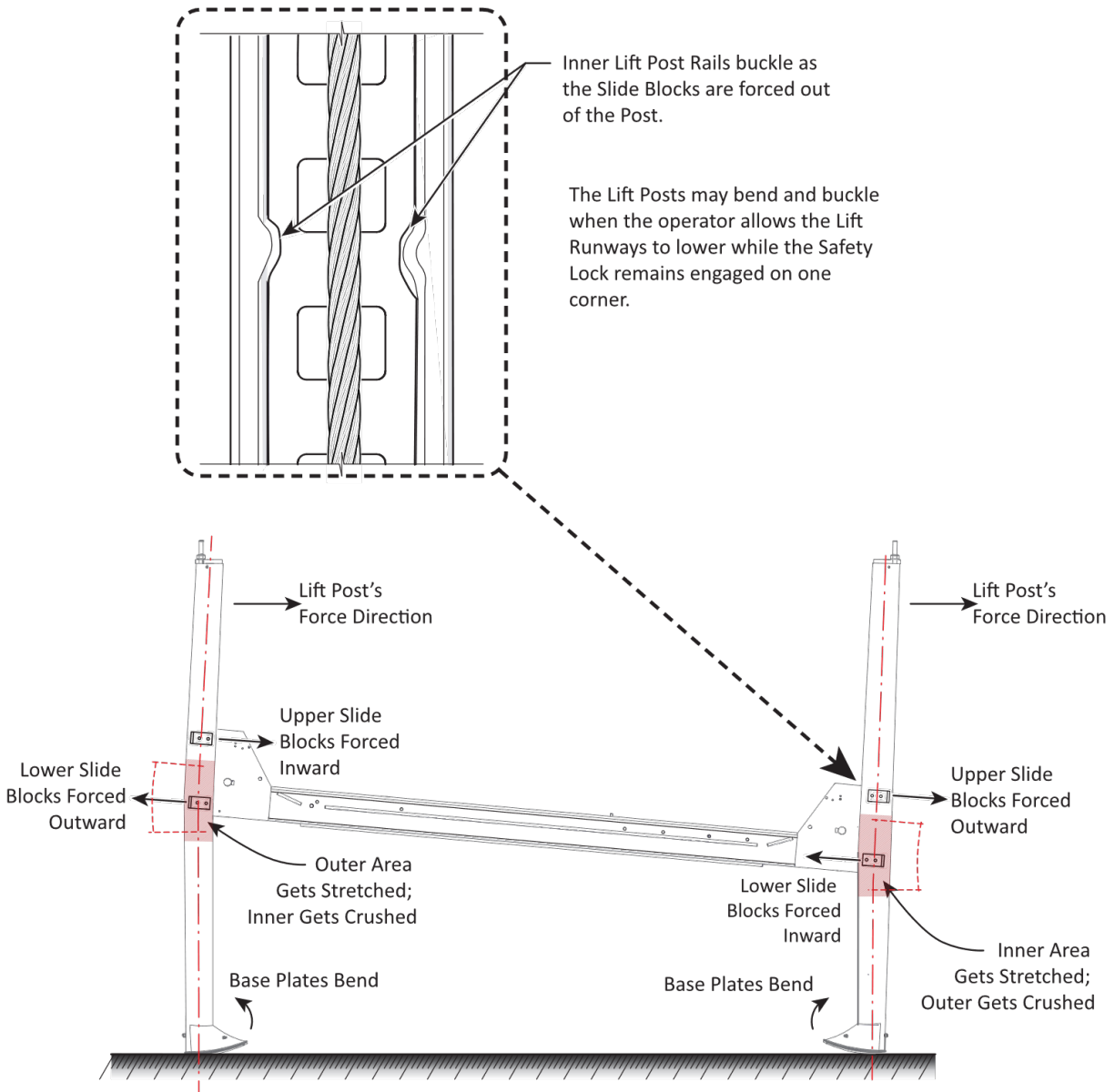

5. If no damage is found, perform the **Lift Cable Adjustment Procedure** found in the **Maintenance** section.

If you continue to have issues with your Lift, take it out of service, then contact your dealer, go to bendpak.com/support, email support@bendpak.com, or call **(800) 253-2363**.

Wiring Diagrams

5585285

208-240VAC
1 PH., 50/60HZ.
3HP

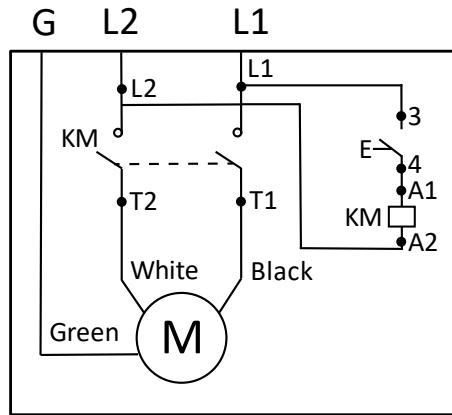

5585785 & 5585780

208-240VAC
1 PH., 50/60 HZ.
2 HP

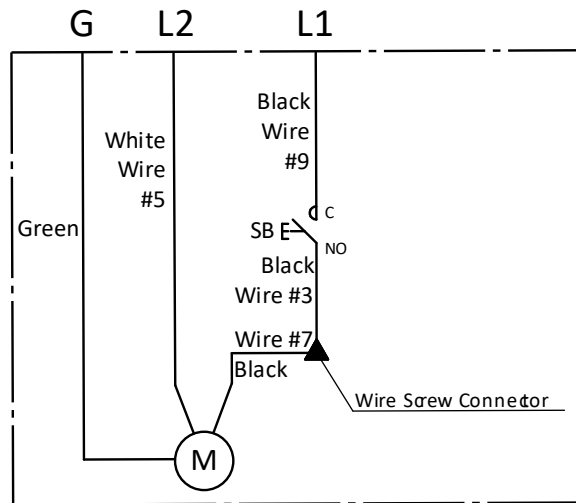

5585175

208-230VAC, 1 PH., 60 HZ. 2HP
220VAC @ 50 HZ.

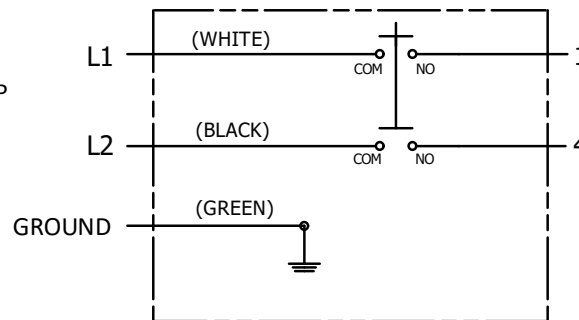

5585285

208-240VAC
1 PH., 50/60HZ.
3HP

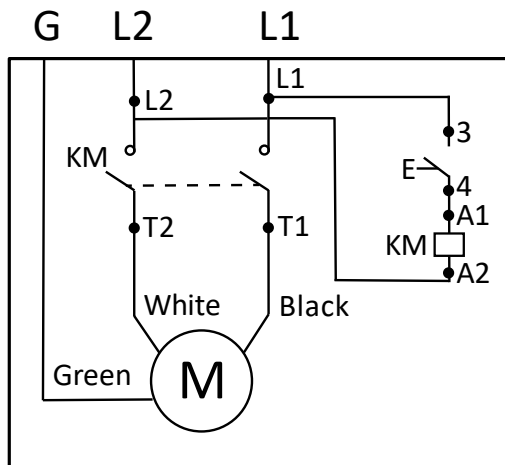

5585785

208-240VAC
1 PH., 50/60 HZ.
2 HP

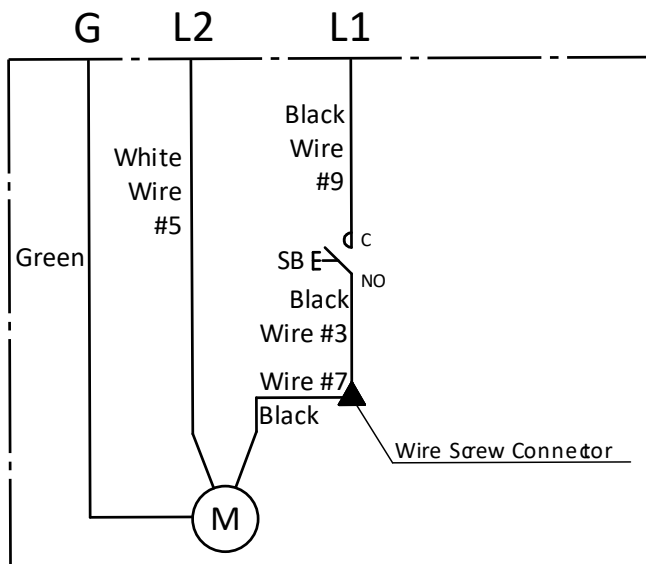

5585175

208-230VAC, 1 PH., 60 HZ. 2HP
220VAC @ 50 HZ.

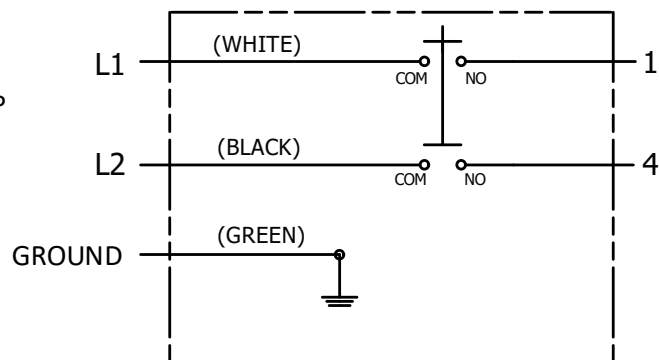

Labels

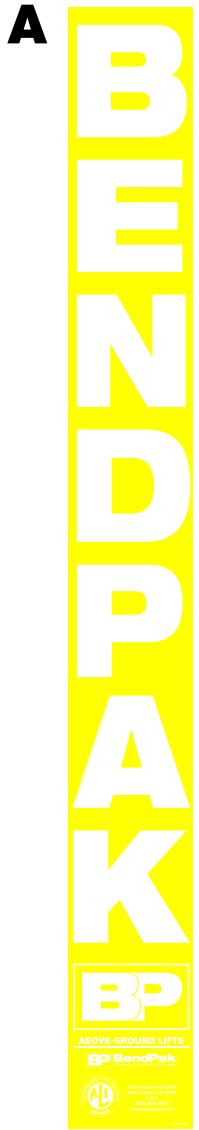

PN 5905311

A DANGER

VISUALLY CONFIRM THAT ALL PRIMARY SAFETY LOCKS ARE ENGAGED BEFORE ENTERING WORK AREA.

Support components on this lift are intended to raise and lower the lift and are not designed to support a load or under a suspended lift. Visual confirmation is made that the lift is supported on the primary safety locks by the manual for proper Safety Lock procedures and additional instructions.

VÉRIFIER VISUELLEMENT QUE TOUTS LES VERROUS DE SÉCURITÉ PRIMAIRES SONT ENGAGÉS AVANT D'ENTRER DANS LA ZONE DE TRAVAIL.

Les composants de suspension de cet élévateur sont destinés à élever et abaisser l'ascenseur, ce ne sont pas des dispositifs de maintien de la charge. Ne pasessayer de soulever ou de maintenir une charge sans avoir vérifié la confirmation visuelle que l'ascenseur est engagé sur ses verrous de sécurité. Reportez-vous au manuel pour connaître les procédures de verrouillage de sécurité et les instructions supplémentaires.

WARNING

Wire Rope Inspection and Maintenance

- Inspect lifting cables for wear or damage as noted, such as excessive fraying, broken strands, corrosion, or other defects.
- Keep wire rope in a safe condition at all times, the rope shall be replaced if it is found to be damaged or worn.
- Do not use damaged or worn cables. Do not use cables that are damaged or worn in any way.
- Do not use cables that are damaged or worn in any way.
- Do not use cables that are damaged or worn in any way.

Failure to read, understand, and follow these instructions may cause death or serious injury. Read and understand these instructions before using lift.

ATTENTION

Inspection et maintenance des câbles

- Inspectez les câbles de levage à l'arrêt de la charge et vérifiez qu'ils ne sont pas usés, endommagés, rouillés ou autrement détériorés.
- Gardez les câbles de levage dans un état sûr à tout moment. Remplacez les câbles de levage usés, endommagés, rouillés ou autrement détériorés.
- Ne pas utiliser de câbles de levage usés, endommagés, rouillés ou autrement détériorés.
- Ne pas utiliser de câbles de levage usés, endommagés, rouillés ou autrement détériorés.
- Ne pas utiliser de câbles de levage usés, endommagés, rouillés ou autrement détériorés.

Read and comprehend these instructions avant d'utiliser l'ascenseur. Ne pas lire, comprendre et suivre ces instructions peut provoquer des blessures graves, voire mortelles.

IMPORTANT OPERATION / MAINTENANCE INSTRUCTIONS - PLEASE READ

TO LOWER LIFT

1. Lower the lift to the ground.
2. Lower the lift to the ground.
3. Lower the lift to the ground.
4. Lower the lift to the ground.
5. Lower the lift to the ground.
6. Lower the lift to the ground.
7. Lower the lift to the ground.
8. Lower the lift to the ground.
9. Lower the lift to the ground.
10. Lower the lift to the ground.

TO LOWER LIFT

1. Abaissez le bras de levage à l'arrêt de la charge.
2. Abaissez le bras de levage à l'arrêt de la charge.
3. Abaissez le bras de levage à l'arrêt de la charge.
4. Abaissez le bras de levage à l'arrêt de la charge.
5. Abaissez le bras de levage à l'arrêt de la charge.
6. Abaissez le bras de levage à l'arrêt de la charge.
7. Abaissez le bras de levage à l'arrêt de la charge.
8. Abaissez le bras de levage à l'arrêt de la charge.
9. Abaissez le bras de levage à l'arrêt de la charge.
10. Abaissez le bras de levage à l'arrêt de la charge.

REGULAR MAINTENANCE

1. Regular maintenance is required.
2. Regular maintenance is required.
3. Regular maintenance is required.
4. Regular maintenance is required.
5. Regular maintenance is required.
6. Regular maintenance is required.
7. Regular maintenance is required.
8. Regular maintenance is required.
9. Regular maintenance is required.
10. Regular maintenance is required.

WARNING

ATTENTION

PN 5905556

C

CAUTION

Lift to be used by trained operator ONLY.

Authorized personnel only in lift area.

WARNING

Clear area if vehicle is in danger of falling.

Remain clear of lift when raising or lowering vehicle.

WARNING

Keep clear of pinch points when lift is moving.

Keep feet clear of lift while lowering.

WARNING

Do not override self-closing lift controls.

Chock wheel to prevent vehicle movement.

NOTICE

Read operating and safety manuals before using lift.

Proper maintenance and inspection is necessary for safe operation.

NOTICE

Do not operate a damaged lift.

PN 5905108

D

DANGER

THE MAXIMUM LIFTING CAPACITY FOR THIS LIFT IS DESCRIBED BELOW

Maximum Lifting Capacity

Max. Lifting Cap. / Front of Lift Center

Max. Lifting Cap. / Rear of Lift Center

Exceeding the weight capacity of this lift can damage lift and/or property and may cause personal harm, injury or death to operators and/or bystanders. All vehicles MUST be positioned on lift with CENTER OF GRAVITY midway between adapters and/or centered on runways. Damage to lift due to overloading or misuse IS NOT covered under warranty.

LA CAPACITÉ DE LEVAGE MAXIMUM POUR CE LEVAGE EST DÉCRIT CI-DESSOUS

Capacité de Levage Maximale

Max. Capuchon De Levage. / Avant du centre de relèvement

Max. Capuchon De Levage. / Arrière du centre de levage

Le dépassement de la capacité de poids de cet élévateur peut endommager l'ascenseur et / ou les biens et peut causer des dommages corporels, des blessures voire la mort aux opérateurs et / ou aux passants. Tous les véhicules DOIVENT être placés sur l'élévateur avec le CENTRE DE GRAVITÉ à mi-chemin entre les adaptateurs et / ou au centre des pistes. Dommages à soulever dus à la surcharge ou une mauvaise utilisation N'EST PAS couverte par la garantie.

P/N 5905557 - Max. Cap. Danger 14k

E

ATTENTION

MAXIMUM LIFTING CAPACITY

CAPACITÉ DE LEVAGE MAXIMUM

14000 Lbs.

6350 Kg.

P/N 5905665 - NRTL Lifting Cap Label 14k

F

BP BendPak

1645 Lemonwood Dr. Santa Paula, CA USA www.BendPak.com

LIFT TYPE: Surface Mount **MANUFACTURER:** BendPak, See data plate for product details

POWER: Electric/Hydraulic **INSTALLATION:** See manual or contact factory

Safety Instructions: If attachments, accessories, or configuration-modifying components that are located in the load path affect operation of the lift, affect the lift electrical listing, or affect intended vehicle accommodation are used on this lift and, if they are not certified for use on this lift, then the certification of this lift shall become null and void. Contact the participant for information pertaining to certified attachments, accessories, or configuration-modifying components.

BendPak lifts are supplied with concrete fasteners meeting the criteria as prescribed by ASTM E488/ E488M-18. Lift buyers are responsible for any special regional, structural, and/or seismic anchoring requirements specified by any other agencies and/or codes such as the Uniform Building Code (UBC) and/or International Building Code (IBC).

The manufacture, use, sale, or import of this product may be subject to one or more United States

PN 5905940

G

NOTICE

If attachments, accessories, or configuration modifying components used on this lift are located in the load path and affect operation of the lift, affect the lift electrical listing, or affect intended vehicle accommodation; and if they are not certified for use on this lift, then the certification of this lift shall become null and void. Contact the participant for information pertaining to certified attachments, accessories, or configuration modifying components.

www.autolift.org ©2011 by ALI, Inc. ALI/WLSIA01

PN 5905377

H

 	⚠ WARNING SLIPPERY WHEN WET OR ICY Use caution when driving onto wet or icy drive-up ramps and platforms. DO NOT walk on lift surfaces that are wet or icy.
	⚠ AVERTISSEMENT GLISSANT LORSQU'IL EST MOUILLÉ OU GLACÉ Soyez prudent lorsque vous conduisez sur des rampes d'accès mouillées ou verglacées et les plateformes. NE PAS marcher sur des surfaces de levage humides ou glacées.

PN 5905138

PN 5905138

I

CERTIFIED AUTOMOTIVE LIFT



ALI CERTIFIED
To the provisions of ANSI/ALI ALC-TV-2017 SAFETY REQUIREMENTS FOR CONSTRUCTION, TESTING AND VALIDATION

Automotive Lift Institute, Inc. | Cortland, NY 13045

ALI CERTIFIED

MET LISTED
Conforms to ANSI/UL 201 SAFETY STANDARD FOR GARAGE EQUIPMENT

Certified to CAN/CSA C22.2 NO.68 MOTOR OPERATED APPLIANCES (HOUSEHOLD & COMMERCIAL)

MET Laboratories, Inc. | BALTIMORE, MD 21232

Certification Label Serial Number

AL00617000M

PN 5905654

**FOR ALI APPROVED LIFTS ONLY

K

BP BendPak Santa Paula, CA USA
www.bendpak.com

MODEL NUMBER	
DESCRIPTION	
LIFT CAPACITY	DATE CODE
ROLLING JACK MAX CAP.	MAX PSI / BAR
VOLTAGE	SERIAL NUMBER
<input type="checkbox"/> 110-240V, 50-60 Hz, 1 Ph <input type="checkbox"/> 208-240V, 50-60 Hz, 1 Ph <input type="checkbox"/> 380-415V, 50-60 Hz, 3 Ph <input type="checkbox"/> 208-440V, 50-60 Hz, 3 Ph	
UPC	

⚠ DANGER! Disconnect Power Before Servicing
ERC
WARRANTY VOID IF DATA PLATE IS REMOVED PN 5905952

PN 5905952

L

PN 5906044

M

CALIFORNIA PROPOSITION 65

⚠ WARNING ⚠

WARNING! This product can expose you to chemicals including styrene and vinyl chloride which are on the list of over 900 chemicals identified by the State of California to cause cancer, birth defects or reproductive harm. ALWAYS use this product in accordance with the manufacturer's instructions.

For more information, go to www.p65warnings.ca.gov.

PN 5905775

PN 5905775

**SEE NEXT PAGE
FOR LABEL
PLACEMENT HEIGHT**

****FOR ALL APPROVED
LIFTS ONLY**

M, E, C

**Back of Post
(Top to Bottom)**

**G, D, I,
J or K, F**

**Front of Post
(Top to Bottom)**

**B
Side of Post**

**A
(Front & Back of post)**

**A
(Front & Back of post)**



**A
(Front & Back of post)**

**H
(Back of post)**

**H
(Also on other side of lift)**

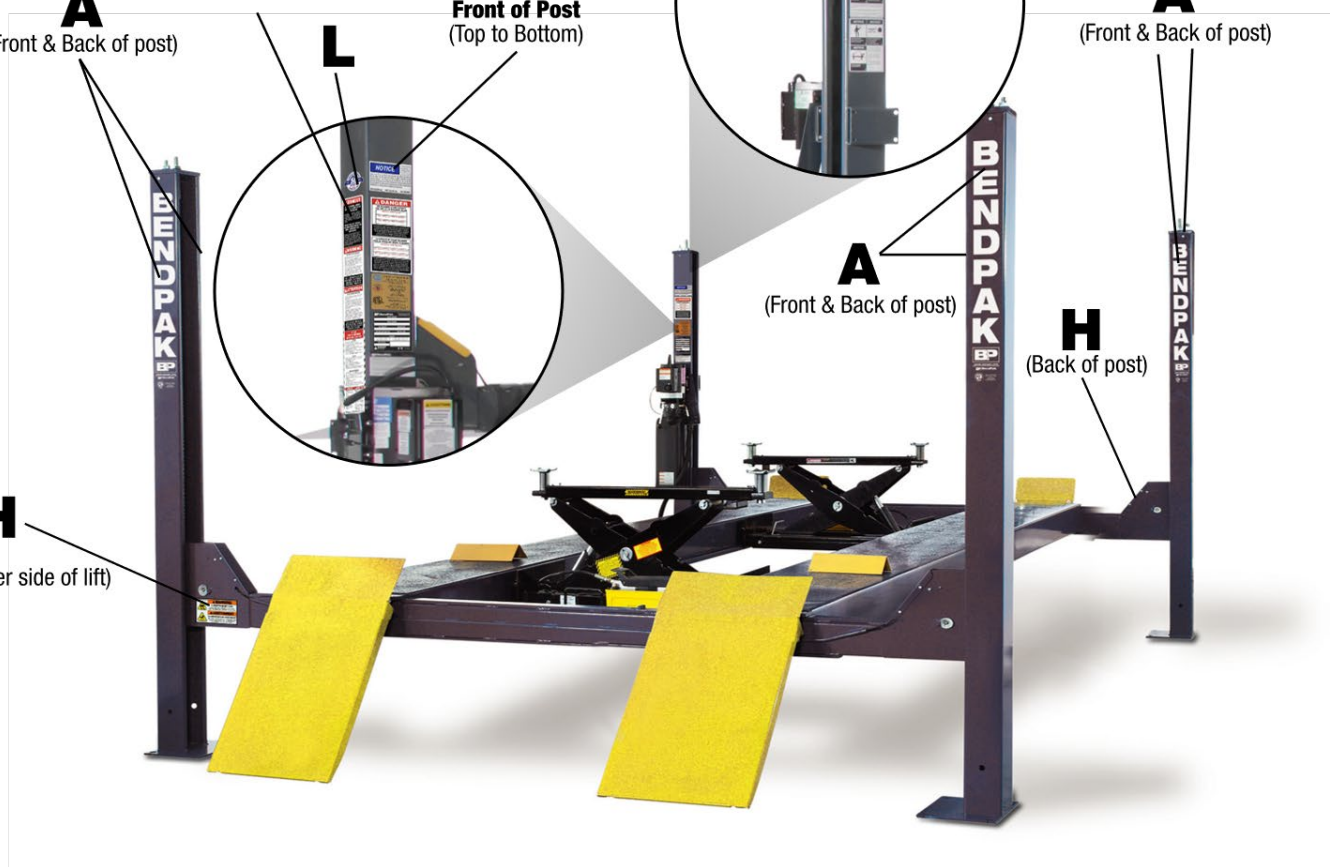

Views of Powerside Post

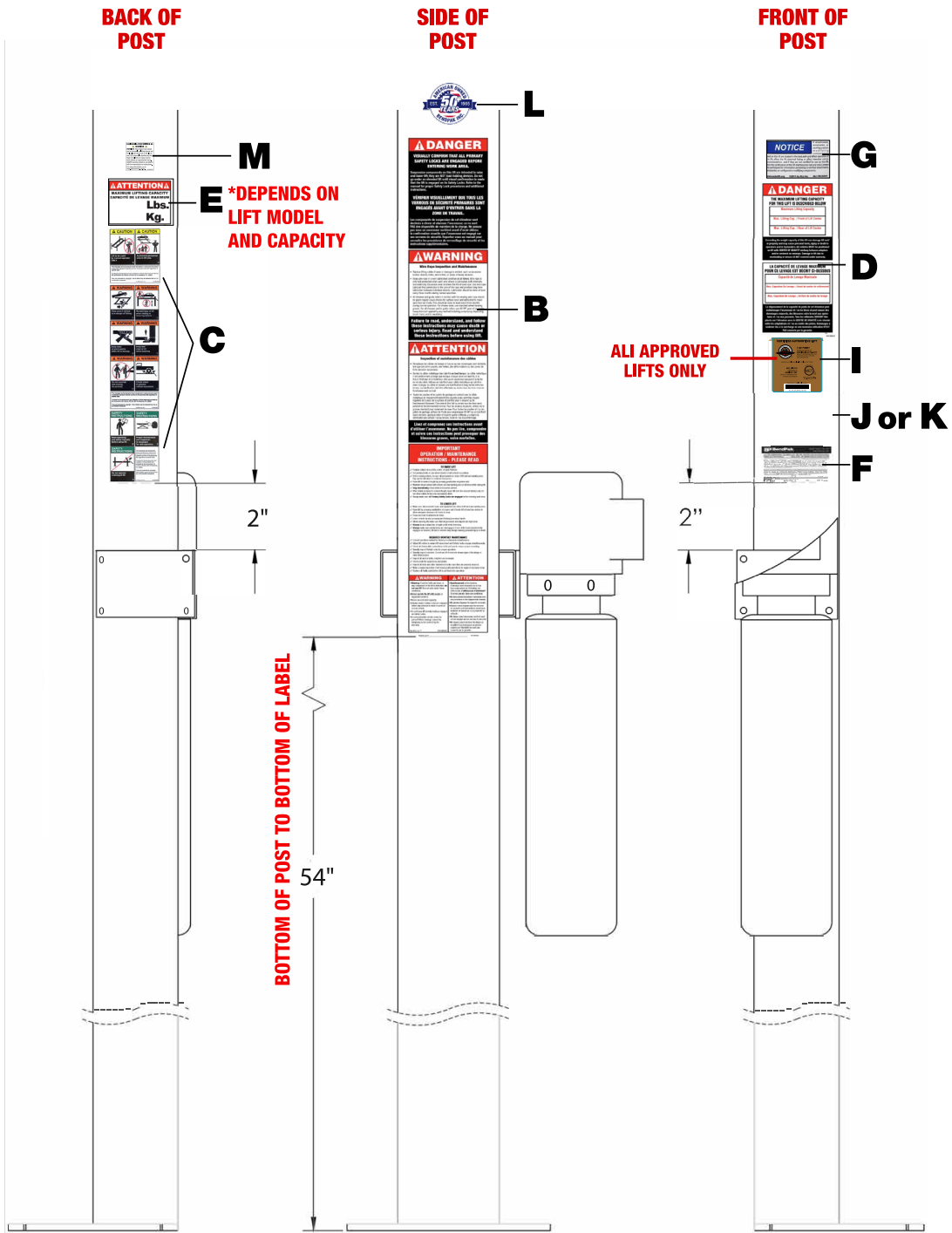

Parts Drawings

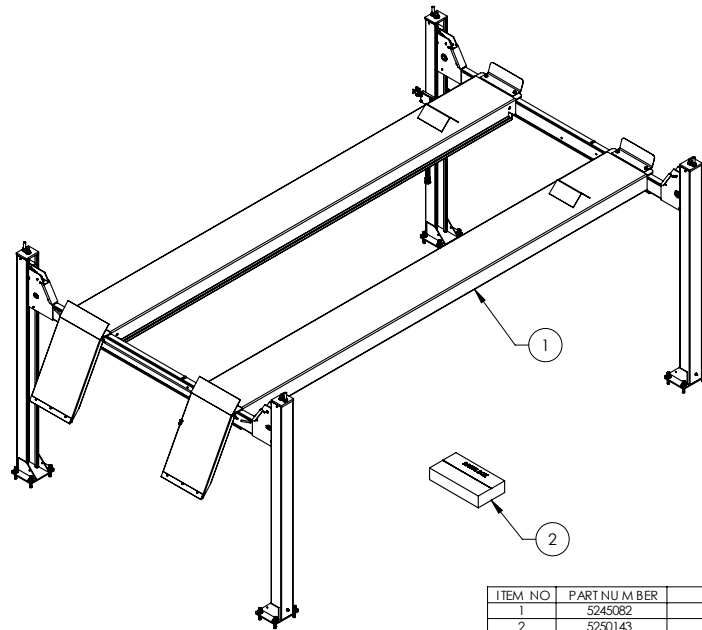

NOTE: UNLESS OTHERWISE SPECIFIED

1. REFER TO MODEL FOR ADDITIONAL INFORMATION
2. SEE COLORS & GRAPHICS FOR LABEL PLACEMENT
3. SEE SHIPPING INSTRUCTIONS FOR FINAL PACKAGING

ITEM NO	PART NUMBER	DESCRIPTION	QTY	REV
1	5245082	HDS-14 LIFT SUPERSTRUCTURE	1	J
2	5250143	HDS-14 PARTS BOX	1	L

DONOT SCALE DRAWING		NAME	DATE	 1645 LEMONWOOD DR. SANTA PAULA, CA 93060
DRAWN	TM	11/25/2019		
DIMENSIONS ARE IN MM		CHECKED		TITLE: HDS-14 PRODUCTION LIFT VER D (CE CERT) SIZE: DWG. NO. 5260598 REV L SCALE: 1:40 SHEET 1 OF 3
		THIRD ANGLE PROJECTION		

PROPRIETARY AND CONFIDENTIAL
THIS DRAWING IS THE PROPERTY OF BENDPAK INC. ANY REPRODUCTION IN ANY MANNER WITHOUT THE WRITTEN PERMISSION OF BENDPAK INC. IS PROHIBITED.

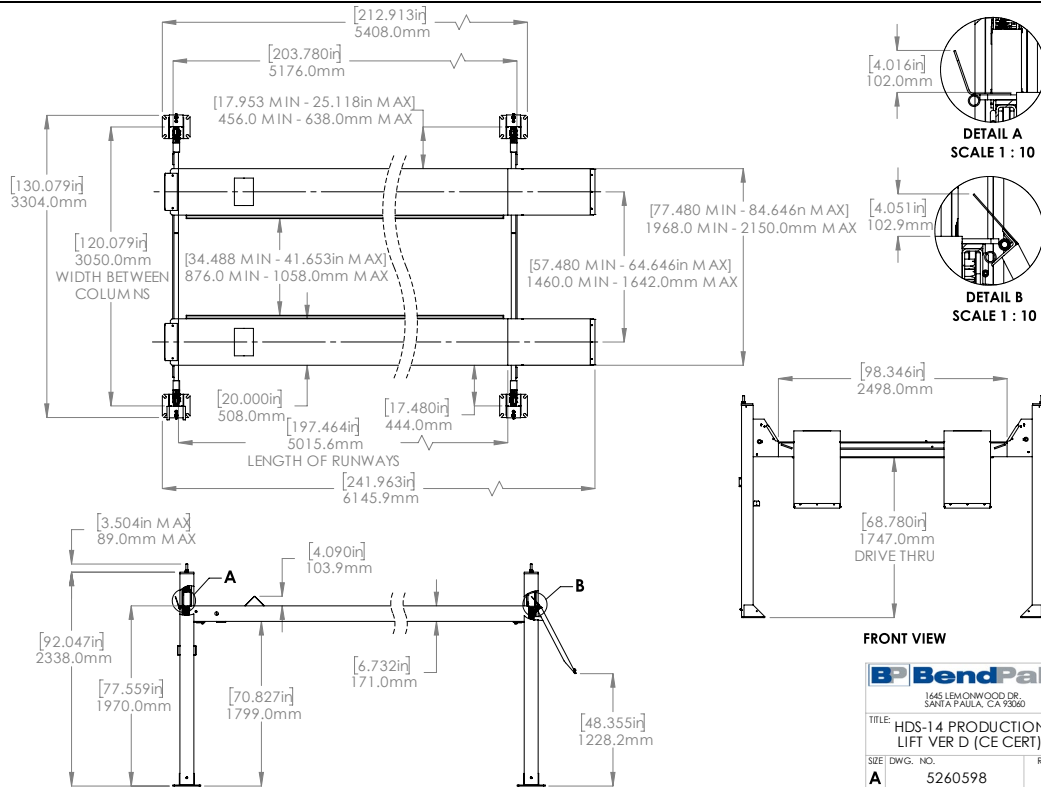

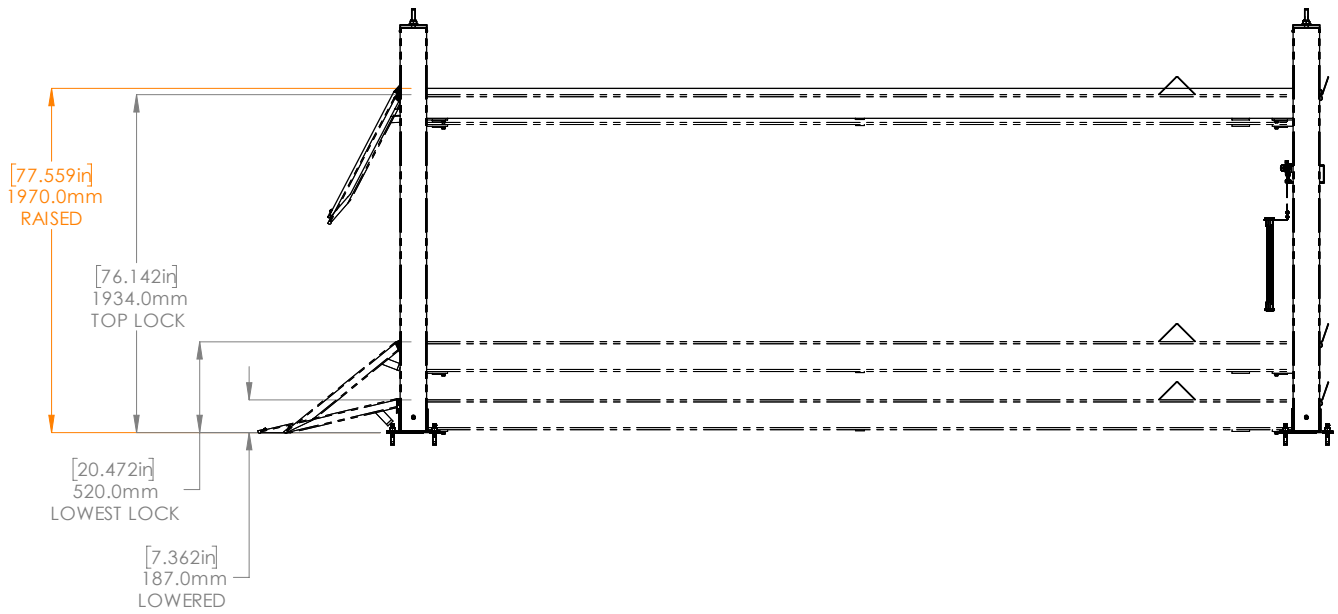

BendPak
 1645 LEMONWOOD DR.
 SANTA PAULA, CA 93060

TITLE: HDS-14 PRODUCTION LIFT VER D (CE CERT)

SIZE DWG. NO. REV
A 5260598 L

SCALE: 1:30 SHEET 3 OF 3

1. DIMENSIONS ARE SHOWN WITH LOCK LADDERS ADJUSTED ALL THE WAY UP

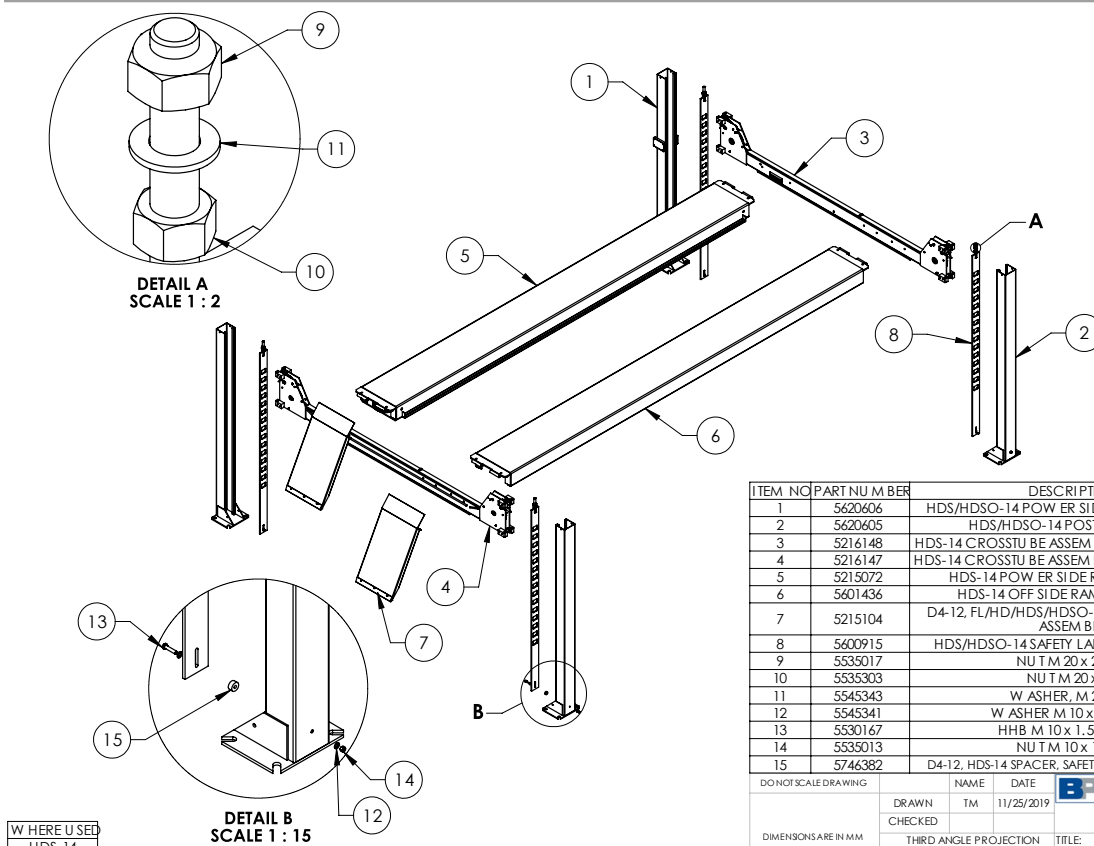

WHERE USED
 HDS-14

NOTE: UNLESS OTHERWISE SPECIFIED

- REFER TO MODEL FOR ADDITIONAL INFORMATION
- SEE SHIPPING INSTRUCTIONS FOR FINAL PACKAGING
- THREAD M 20 HARDWARE ONTO LADDER BOLTS AS SHOWN

NEXT ASSEMBLY
 5260598

ITEM NO	PART NUMBER	DESCRIPTION	QTY	REV
1	5620606	HDS/HDSO-14 POWER SIDE POST W ELDMENT	1	C
2	5620605	HDS/HDSO-14 POST W ELDMENT	3	C
3	5216148	HDS-14 CROSS TUBE ASSEMBLY, SMALL WINDOW	1	A
4	5216147	HDS-14 CROSS TUBE ASSEMBLY, LARGE WINDOW	1	A
5	5215072	HDS-14 POWER SIDE RAMP ASSEMBLY	1	V
6	5601436	HDS-14 OFF SIDE RAMP W ELDMENT	1	B
7	5215104	D4-12, FL/HD/HDS/HDSO-14 DRIVE RAMP ASSEMBLY	2	K
8	5600915	HDS/HDSO-14 SAFETY LADDER W ELDMENT	4	B
9	5535017	NU T M 20 x 2.5 NL	4	-
10	5535303	NU T M 20 x 2.5	4	-
11	5545343	W ASHER, M 20 FLAT	4	-
12	5545341	W ASHER M 10 x Ø20 FLAT	8	-
13	5530167	HHB M 10 x 1.5 x 45mm	4	-
14	5535013	NU T M 10 x 1.5 NL	4	-
15	5746382	D4-12, HDS-14 SPACER, SAFETY LADDER, 15mm LG.	4	A

DO NOT SCALE DRAWING

DRAWN: TM DATE: 11/25/2019

CHECKED: _____

DIMENSIONS ARE IN MM

THIRD ANGLE PROJECTION

BendPak
 1645 LEMONWOOD DR.
 SANTA PAULA, CA 93060

TITLE: HDS-14 LIFT SUPERSTRUCTURE

SIZE DWG. NO. REV
A 5245082 J

SCALE: 1:50 SHEET 1 OF 1

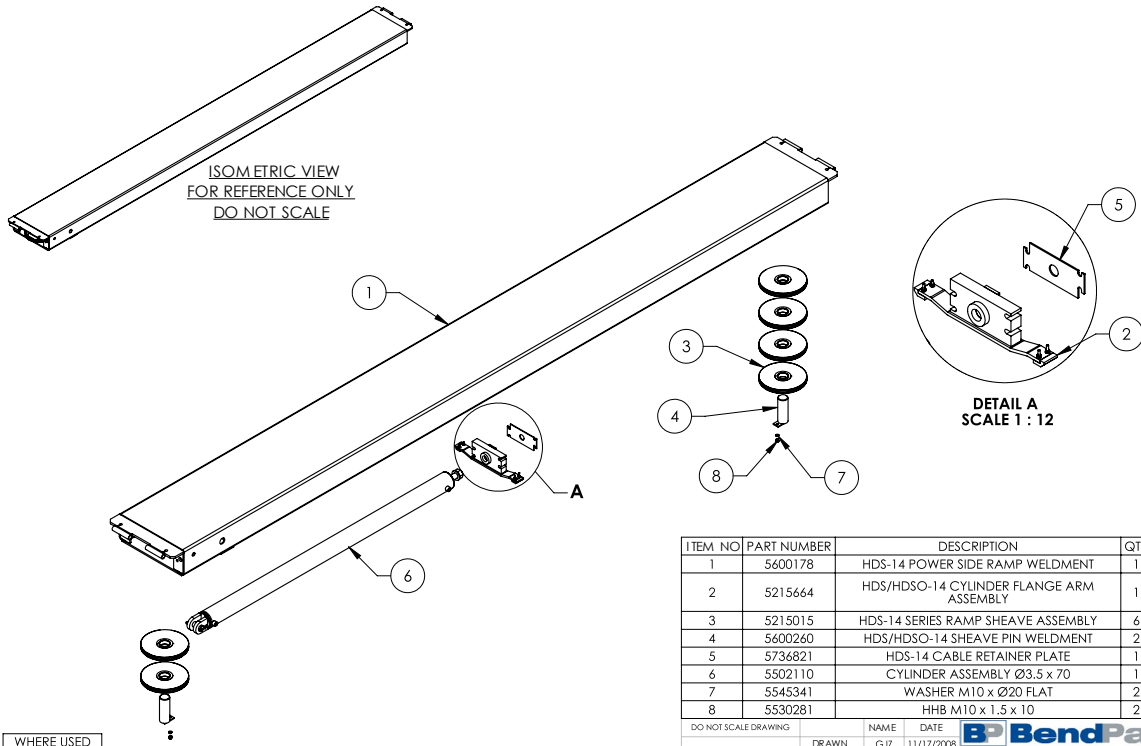

- NOTE: UNLESS OTHERWISE SPECIFIED**
1. REFER TO MODEL FOR ADDITIONAL INFORMATION
 2. VERIFY CYLINDER PORTS ARE CAPPED OFF WITH STEEL 3/8" NPT PLUG
 3. SEE SHIPPING INSTRUCTIONS FOR FINAL PACKAGING
 4. ASSEMBLE ITEMS AS SHOWN

ITEM NO	PART NUMBER	DESCRIPTION	QTY	REV
1	5600178	HDS-14 POWER SIDE RAMP WELDMENT	1	F
2	5215664	HDS/HDSO-14 CYLINDER FLANGE ARM ASSEMBLY	1	A
3	5215015	HDS-14 SERIES RAMP SHEAVE ASSEMBLY	6	C
4	5600260	HDS/HDSO-14 SHEAVE PIN WELDMENT	2	C
5	5736821	HDS-14 CABLE RETAINER PLATE	1	A
6	5502110	CYLINDER ASSEMBLY Ø3.5 x 70	1	L
7	5545341	WASHER M10 x Ø20 FLAT	2	-
8	5530281	HHB M10 x 1.5 x 10	2	-

DO NOT SCALE DRAWING

DRAWN: G/JZ NAME: G/JZ DATE: 11/17/2008

CHECKED: BENDPAK INC. 1645 LEMONWOOD DR. SANTA PAULA, CA 93060

DIMENSIONS ARE IN MM THIRD ANGLE PROJECTION TITLE: HDS-14 POWER SIDE RAMP ASSEMBLY

PROPRIETARY AND CONFIDENTIAL THE INFORMATION CONTAINED IN THIS DRAWING IS THE PROPERTY OF BENDPAK INC. AND IS TO BE USED ONLY FOR THE PROJECT AND IN THE MANNER SPECIFIED BY BENDPAK INC. WITHOUT THE WRITTEN PERMISSION OF BENDPAK INC. IS PROHIBITED.

SIZE: DWG. NO. REV SCALE: 1:25 SHEET 1 OF 2

A 5215072 V

NEXT ASSEMBLY
5245082

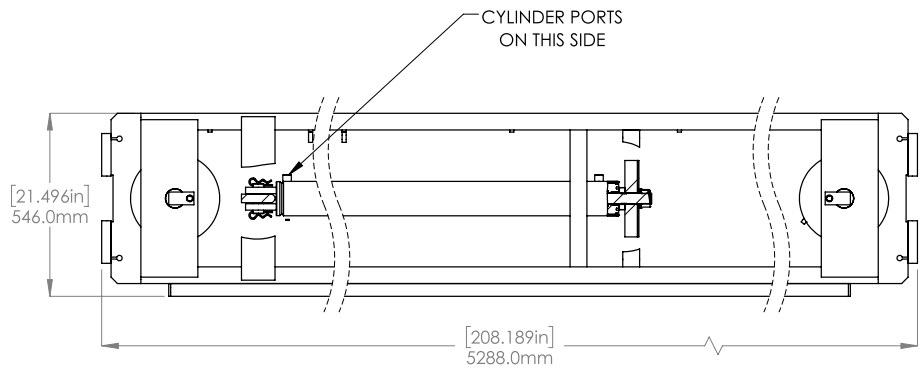
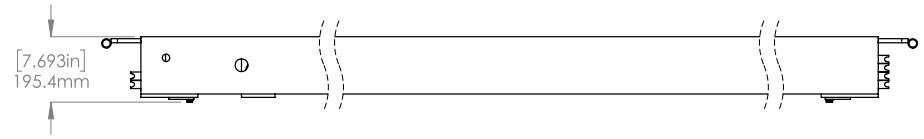

BendPak
1645 LEMONWOOD DR.
SANTA PAULA, CA 93060

TITLE: HDS-14 POWER SIDE RAMP ASSEMBLY

SIZE: DWG. NO. REV SCALE: 1:15 SHEET 2 OF 2

A 5215072 V

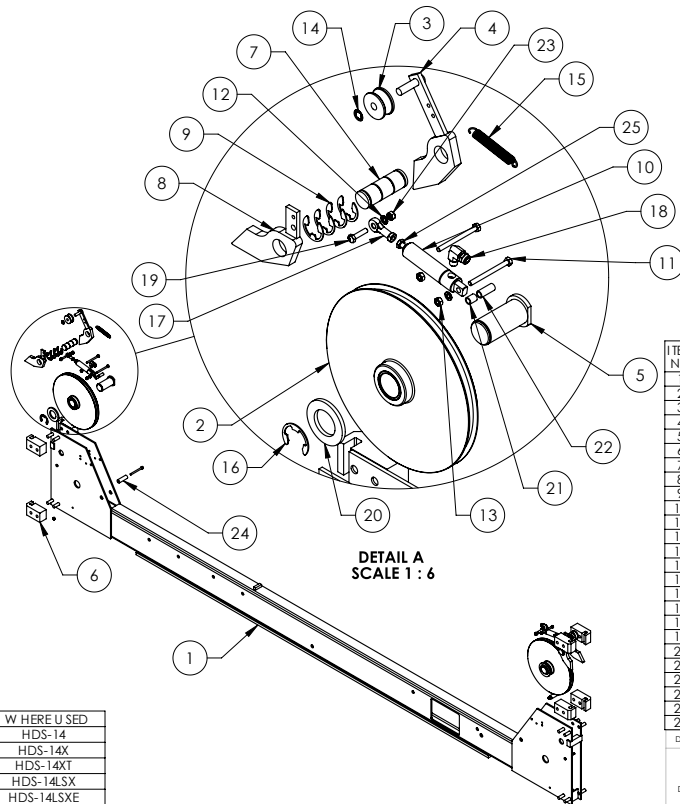

W HERE U SED
HDS-14
HDS-14X
HDS-14XT
HDS-14LSX
HDS-14LSXE

- NOTE: UNLESS OTHERWISE SPECIFIED**
1. REFER TO MODEL FOR ADDITIONAL INFORMATION
 2. SEE SHIPPING INSTRUCTIONS FOR FINAL PACKAGING
 3. ASSEMBLE ITEMS AS SHOWN

ITEM NO	PART NUMBER	DESCRIPTION	QTY	REV
1	5601814	HDS-14 CROSSTUBE W ELDMENT, LARGE WINDOW	1	A
2	5215013	FL14/HDS-14 CROSSTUBE SHEAVE ASSEMBLY	2	B
3	5575380	D4-12, FL14, HD/HDS/HDSO-14 SAFETY ROLLER	2	C
4	5600044	4 POST LIGHT DUTY SLACK SAFETY W ELDMENT	2	F
5	5600173	D4-12, HD/HDS/HDSO-14 SHEAVE PIN W ELDMENT	2	G
6	5716005	CROSSTUBE POLYETHYLENE SLIDE BLOCK	8	M
7	5746008	HD/HDS-77500/9/14, HDSO-14 SAFETY PIN	2	D
8	5600760	FL14/HDS/HDS LIGHT DUTY SAFETY W ELDMENT	2	C
9	5540275	ERING Ø25mm OD DIN 6799 0250	8	-
10	5502195	AIR CYLINDER, Ø19mm x 25 STROKE	2	-
11	5530005	HHB M 6 x 1 x 70	6	-
12	5545005	W ASHER M 6 x 12 FLAT, CL 10.9	4	-
13	5535112	NU T M 6 x 1.0	4	-
14	5505030	PUSH-ON CLIP Ø10mm SS	2	-
15	5540065	SPRING Ø13mm x 90mm, SLACK SAFETY	2	A
16	5540002	ERING Ø1.375" OD TRU ARC X5133-137	2	-
17	5505625	FEMALE ROD END M 6 x 33	2	-
18	5550087	FTG ELB -04 COM P x -02 NPT	2	-
19	5530756	HHB M 6 x 1.0 x 25 FT, CL 10.9	2	-
20	5545032	W ASHER M 36 x 66 FLAT	2	-
21	5755136	AIR CYLINDER SPACER 12mm	2	A
22	5755137	AIR CYLINDER SPACER 25mm	2	A
23	5535357	NU T M 6 x 1.0 NL, CL 10.9	4	-
24	5755157	CROSSTUBE END PLATE SPACER, 50mm	2	A
25	5535230	NU T 1/4-28 JN	2	-

DO NOT SCALE DRAWING

NAME: _____ DATE: 04/28/2022

DRAWN: TM

CHECKED: OR 6/10/2022

THIRD ANGLE PROJECTION

PROPRIETARY AND CONFIDENTIAL
THE INFORMATION CONTAINED HEREIN IS THE SOLE PROPERTY OF BENDPAK INC. ANY REPRODUCTION OR TRANSMISSION OF THIS INFORMATION WITHOUT THE WRITTEN PERMISSION OF BENDPAK INC. IS PROHIBITED.

BendPak
1645 LEMONWOOD DR.
SANTA PAULA, CA 93060

TITLE: HDS-14 CROSSTUBE ASSEMBLY, LARGE WINDOW

SIZE: DWG. NO. 5216147 REV A

SCALE: 1:20 SHEET 1 OF 1

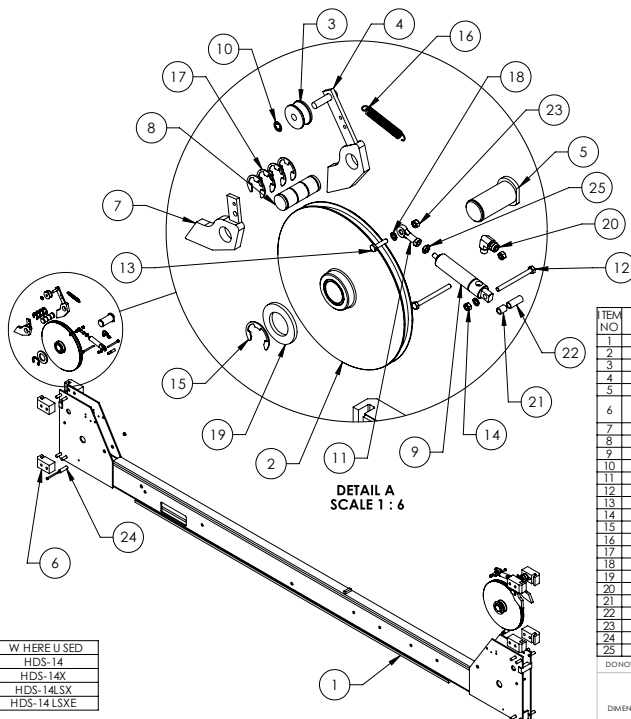

W HERE U SED
HDS-14
HDS-14X
HDS-14LSX
HDS-14LSXE

- NOTE: UNLESS OTHERWISE SPECIFIED**
1. REFER TO MODEL FOR ADDITIONAL INFORMATION
 2. SEE SHIPPING INSTRUCTIONS FOR FINAL PACKAGING
 3. ASSEMBLE ITEMS AS SHOWN

ITEM NO	PART NUMBER	DESCRIPTION	QTY	REV
1	5601826	HDS-14 CROSSTUBE W ELDMENT, SM ALL WINDOW	1	A
2	5215013	HDS-14 CROSSTUBE SHEAVE ASSEMBLY	2	B
3	5575380	D4-12, HD/HDS/HDSO-14 SAFETY ROLLER	2	C
4	5600044	4 POST LIGHT DUTY SLACK SAFETY W ELDMENT	2	F
5	5600173	D4-12, HD/HDS/HDSO-14 SHEAVE PIN W ELDMENT	2	G
6	5716005	D4-12, HD-77500/9/14/HDSO-14 POLYETHYLENE SLIDE BLOCK	8	M
7	5600760	D4-12, HD/HDS LIGHT DUTY SAFETY W ELDMENT	2	C
8	5746008	D4-12, HD/HDS-77500/9/14, HDSO-14 SAFETY PIN	2	D
9	5502195	AIR CYLINDER, Ø19mm x 25 STROKE	2	-
10	5530005	PUSH-ON CLIP Ø10mm SS	2	-
11	5505625	FEMALE ROD END M 6 x 33	2	-
12	5530005	HHB M 6 x 1 x 70	6	-
13	5530756	HHB M 6 x 1.0 x 25mm	2	-
14	5535112	NU T M 6 x 1.0	2	-
15	5540002	ERING Ø1.375" OD TRU ARC X5133-137	2	-
16	5540065	SPRING Ø13mm x 90mm, SLACK SAFETY	2	A
17	5540275	ERING Ø25mm OD DIN 6799 0250	8	-
18	5545005	W ASHER, M 6 x 12mm FLAT	4	-
19	5545032	W ASHER M 36 x 66 FLAT	2	-
20	5550087	FTG ELB -04 COM P x -02 NPT	2	-
21	5755136	AIR CYLINDER SPACER 12mm	2	A
22	5755137	AIR CYLINDER SPACER 25mm	2	A
23	5535357	NU T M 6 x 1.0 NL	4	-
24	5755157	D4-12, HD-77500/9 CROSSTUBE SPACER Ø16 x Ø10 x 50	2	A
25	5535230	NU T 1/4-28 JN	2	-

DO NOT SCALE DRAWING

NAME: _____ DATE: 05/02/2022

DRAWN: TM

CHECKED: _____

THIRD ANGLE PROJECTION

PROPRIETARY AND CONFIDENTIAL
THE INFORMATION CONTAINED HEREIN IS THE SOLE PROPERTY OF BENDPAK INC. ANY REPRODUCTION OR TRANSMISSION OF THIS INFORMATION WITHOUT THE WRITTEN PERMISSION OF BENDPAK INC. IS PROHIBITED.

BendPak
1645 LEMONWOOD DR.
SANTA PAULA, CA 93060

TITLE: HDS-14 CROSSTUBE ASSEMBLY, SM ALL WINDOW

SIZE: DWG. NO. 5216148 REV A

SCALE: 1:20 SHEET 1 OF 1

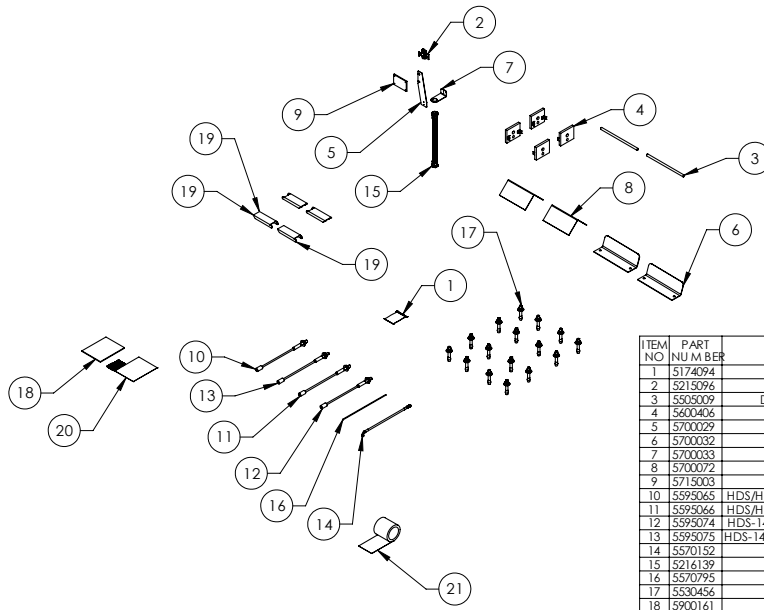

ITEM NO	PART NUMBER	DESCRIPTION	QTY	REV
1	5174094	D4-12, HD/HDS-14 PARTS BAG	1	G
2	5215096	PUSH BUTTON AIR ASSEMBLY	1	G
3	5530009	D4-12, HD/HDS-14 DRIVE UP P/RAMP PIN	2	D
4	5600406	HD/HDS-14 TOP PLATE W/ ELEMENT	4	C
5	5700029	HD-SERIES FLEX TUBE BRACKET PLATE	1	F
6	5700032	TIRE STOP	2	D
7	5700033	HD-SERIES FLEX TUBE ANGLE	1	E
8	5700072	WHEEL CHOCK	2	B
9	5715003	POWER UNIT VIBRATION DAMPENER	1	B
10	5595065	HDS/HDSO-14 CABLE ASSEMBLY Ø12 x 4100mm ST	1	E
11	5595066	HDS/HDSO-14 CABLE ASSEMBLY Ø12 x 5732mm ST	1	E
12	5595074	HDS-14/14L5X CABLE ASSEMBLY Ø12 x 9339mm ST	1	D
13	5595075	HDS-14/14L5X CABLE ASSEMBLY Ø12 x 10990mm ST	1	E
14	5570152	HOSE ASSEMBLY Ø6.4 x 3565mm SB	1	B
15	5216139	FLEX TUBE KIT, UP TO 2000mm	1	A
16	5570795	1/4" POLY-FLO TUBING	20000mm*	--
17	5530456	AB 3/4" x 4 - 3/4"	16	--
18	5900161	HDS-14/14X INSTALLATION MANUAL	1	--
19	5716629	HDS-14 CROSS TUBE COVER, PLASTIC	4	A
20	5210241	4 POST LIGHT DUTY CE PARTS BAG	1	A
21	5930195	ANTI-SLIP TAPE, 6" x 24ft	1	--

WHERE U SEE
HDS-14

NOTE: UNLESS OTHERWISE SPECIFIED

- SEE SHIPPING INSTRUCTIONS FOR FINAL PACKAGING
- HOSES AND CABLES IN REPRESENTATIONAL FORM
- (*) LENGTH FOR REFERENCE ONLY

NEXT ASSEMBLY
5260598

DO NOT SCALE DRAWING

DRAWN	TM	05/03/2013
CHECKED		

DIMENSIONS ARE IN MM

THIRD ANGLE PROJECTION

PROPRIETARY AND CONFIDENTIAL
THE INFORMATION CONTAINED HEREIN IS THE PROPERTY OF BENDPAK INC. ANY REPRODUCTION OR DISSEMINATION OF THIS INFORMATION IN ANY FORM OR BY ANY MEANS WITHOUT THE WRITTEN PERMISSION OF BENDPAK INC. IS PROHIBITED.

1645 LEMONWOOD DR.
SANTA PAULA, CA 93060

TITLE: HDS-14 PARTS BOX

SIZE DWG. NO. A 5250143 REV L

SCALE: 1:35 SHEET 1 OF 1

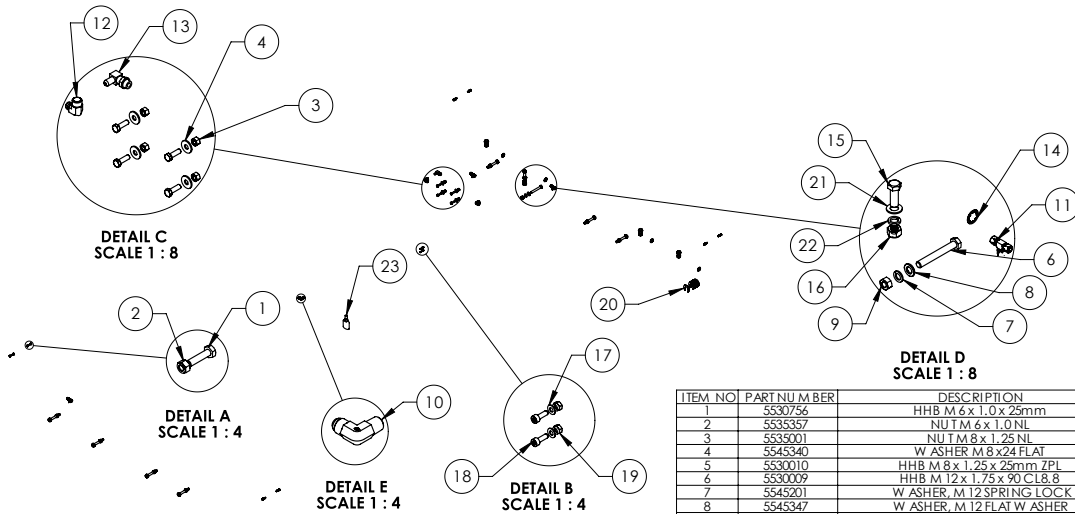

ITEM NO	PART NUMBER	DESCRIPTION	QTY	REV
1	5530756	HHB M 6 x 1.0 x 25mm	8	-
2	5535357	NUT M 6 x 1.0 NL	8	-
3	5535001	NUT M 8 x 1.25 NL	4	-
4	5545340	W ASHER M 8 x 24 FLAT	4	-
5	5530010	HHB M 8 x 1.25 x 25mm ZPL	4	-
6	5530009	HHB M 12 x 1.25 x 90 CL 8	8	-
7	5545201	W ASHER, M 12 SPRING LOCK	8	-
8	5545347	W ASHER, M 12 FLAT W ASHER	8	-
9	5535354	NUT, M 12 x 1.75	8	-
10	5550106	FIG ELB -04 JIC x 3/8" NPT	1	-
11	5550395	FIG TEE -04 COM P x -04 COM P x -04 COM P	3	-
12	5550089	FIG ELB -04 COM P x -06 NPT	2	-
13	5550008	FIG ELB -04 JIC -06L ORB	1	-
14	5505032	ROTOR CLIP Ø18mm SS	4	-
15	5530107	HHB M 14 x 2.0 x 40	4	-
16	5535107	NUT M 14 x 2.0 NL	4	-
17	5545009	W ASHER, M 4 x 9mm FLAT	2	-
18	5530008	SHCS M 4 x 0.7 x 12 BOC	2	-
19	5535010	NUT M 4 x 0.7 NL	2	-
20	5545535	C W ASHER SHIM FOR LIFTS	20	-
21	5545010	W ASHER M 14 x 28 FLAT	4	-
22	5545349	W ASHER M 14 x 22 SL	4	-
23	5580012	LIQUID PTFE THREAD SEALANT 50ml	1	-

WHERE U SEE
HD-14T
HDS-14 SERIES
D4-12 SERIES

NOTE: UNLESS OTHERWISE SPECIFIED

- REFER TO MODEL FOR ADDITIONAL INFORMATION
- SEE SHIPPING INSTRUCTIONS FOR FINAL PACKAGING

NEXT ASSEMBLY
5250143
5250144
5250191
5250194
5250195
5250294
5250295

DO NOT SCALE DRAWING

DRAWN	AC	08/08/2008
CHECKED	OR	09/21/2021

DIMENSIONS ARE IN MM

THIRD ANGLE PROJECTION

PROPRIETARY AND CONFIDENTIAL
THE INFORMATION CONTAINED HEREIN IS THE PROPERTY OF BENDPAK INC. ANY REPRODUCTION OR DISSEMINATION OF THIS INFORMATION IN ANY FORM OR BY ANY MEANS WITHOUT THE WRITTEN PERMISSION OF BENDPAK INC. IS PROHIBITED.

1645 LEMONWOOD DR.
SANTA PAULA, CA 93060

TITLE: D4-12, HD/HDS-14 PARTS BAG

SIZE DWG. NO. A 5174094 REV G

SCALE: 1:30 SHEET 1 OF 1

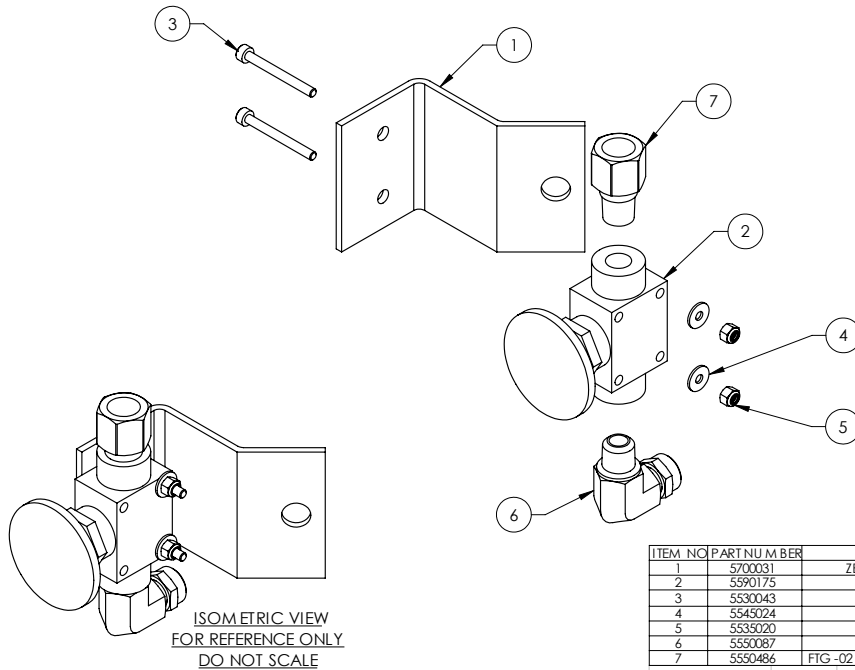

ITEM NO	PART NUMBER	DESCRIPTION	QTY	REV
1	5700031	ZERO ANGLE MOUNTING BRACKET	1	C
2	5590175	PUSH BUTTON AIR VALVE	1	-
3	5530043	SHCS M 3 x 0.5 x 30	2	-
4	5545024	W ASHER, M 3 x 9mm FLAT	2	-
5	5535020	NUT M 3 x 0.5, NL CL8	2	-
6	5550087	FTG ELB -04 COMP x -02 NPT	1	-
7	5550486	FTG -02 NPTF x -04 F NPTF, STRAIGHT EXPANDER	1	-

DO NOT SCALE DRAWING	NAME	DATE	 1645 LEMONWOOD DR. SANTA PAULA, CA 93060
	DRAWN AC	03/14/2008	
	CHECKED CA	09/02/2015	
	THIRD ANGLE PROJECTION		TITLE: PUSH BUTTON AIR ASSEMBLY
			SIZE DWG. NO. 5215096
	PROPRIETARY AND CONFIDENTIAL THE INFORMATION CONTAINED IN THIS DRAWING IS THE SOLE PROPERTY OF BENDPAK INC. ANY REPRODUCTION OR TRANSMISSION OF THIS DRAWING WITHOUT THE WRITTEN PERMISSION OF BENDPAK INC IS PROHIBITED.		REV G
	SCALE: 2:3		SHEET 1 OF 1

NEXT ASSEMBLY
D4-12 SERIES
FL14 SERIES
HD SERIES
HDS SERIES
HDSO SERIES
PL-12000DP

NOTE: UNLESS OTHERWISE SPECIFIED
 1. SEE SHIPPING INSTRUCTIONS FOR FINAL PACKAGING
 2. ASSEMBLE ITEMS AS SHOWN

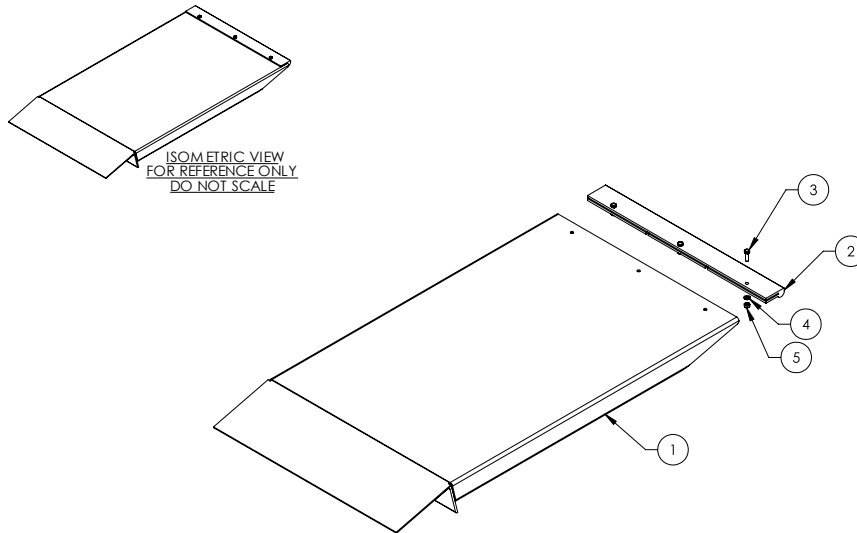

ITEM NO	PART NUMBER	DESCRIPTION	QTY	REV
1	5600138	D4-12, HD/HDS/HDSO-14 DRIVE UP RAMP W ELDMENT	1	H
2	5716087	HDS-14 APPROACH RAMP EDGE GUARD	1	A
3	5530093	HHB M6 x 1.0 x 20mm	3	-
4	5545005	WASHER, M6 x 12mm FLAT	3	-
5	5535357	NUT M6 x 1.0, NL CL8	3	-

DO NOT SCALE DRAWING	NAME	DATE	 1645 LEMONWOOD DR. SANTA PAULA, CA 93060
	DRAWN TM	04/04/2008	
	CHECKED OR	12/13/2022	
	THIRD ANGLE PROJECTION		TITLE: D4-12, FL/HD/HDS/HDSO-14 DRIVE UP RAMP ASSEMBLY
			SIZE DWG. NO. 5215104
	PROPRIETARY AND CONFIDENTIAL THE INFORMATION CONTAINED IN THIS DRAWING IS THE SOLE PROPERTY OF BENDPAK INC. ANY REPRODUCTION OR TRANSMISSION OF THIS DRAWING WITHOUT THE WRITTEN PERMISSION OF BENDPAK INC IS PROHIBITED.		REV K
	SCALE: 1:8		SHEET 1 OF 2

NEXT ASSEMBLY
5210743
5245081
5245082
5245083
5245084
5245085
5245095
5245096
5245416
5245417

WHERE USED
D4-12 SERIES
FL14 SERIES
HD-14T
HDS-14 SERIES
HDSO-14 SERIES

NOTE: UNLESS OTHERWISE SPECIFIED
 1. REFER TO MODEL FOR ADDITIONAL INFORMATION
 2. SEE SHIPPING INSTRUCTIONS FOR FINAL PACKAGING
 3. ASSEMBLE ITEMS AS SHOWN

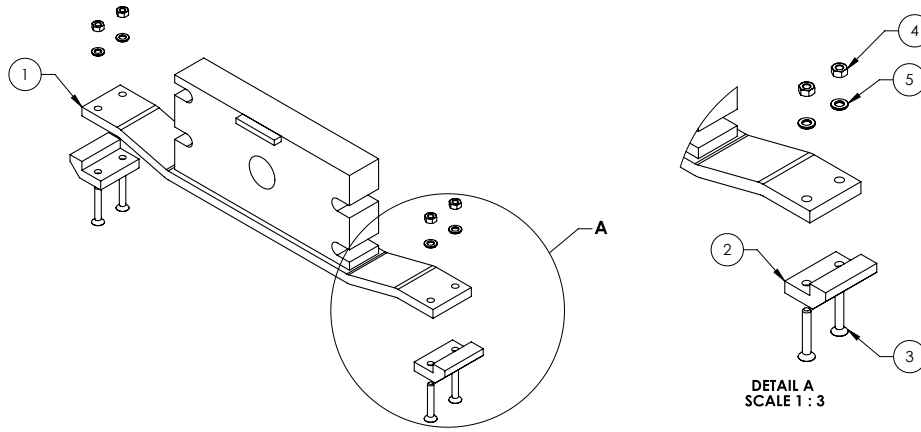

WHERE USED
HDS-14
HDS-14X
HDSO-14

- NOTE: UNLESS OTHERWISE SPECIFIED.**
- SEE SHIPPING INSTRUCTIONS FOR FINAL PACKAGING
 - ASSEMBLE ITEMS AS SHOWN

NEXT ASSEMBLY
5210228
5213079
5215227
5215241

ITEM NO	PART NUMBER	DESCRIPTION	QTY	REV
1	5600924	HDS/HDSO-14 CYLINDER FLANGE ARM, W ELDMENT	1	A
2	5716006	HD/HDS/HDSO-14 CYLINDER FLANGE ARM SLIDE	2	F
3	5530247	FHPS M 6 x 1 x 40	4	-
4	5535112	NIJ T M 6 x 1.0	4	-
5	5545005	M 6 FLAT W. ASHER	4	-

DO NOT SCALE DRAWING	NAME	DATE	BendPak.	
DRAWN	TM	08/04/2014	1645 LEMONWOOD DR. SANTA PAULA, CA 93060	
CHECKED	AW	7/27/2017	TITLE: HDS/HDSO-14 CYLINDER FLANGE ARM ASSEMBLY	
THIRD ANGLE PROJECTION			SIZE	REV
			DWG. NO. A 5215664	C
DIMENSIONS ARE IN MM TOLERANCES: 0.1 = ±1.5 0.0 = ±0.5 ANGULAR: 0.1 = ±2° SURFACE FINISH: 1 & 3D R0.0mm UNLESS OTHERWISE SPECIFIED			SCALE: 1:4 SHEET 1 OF 1	

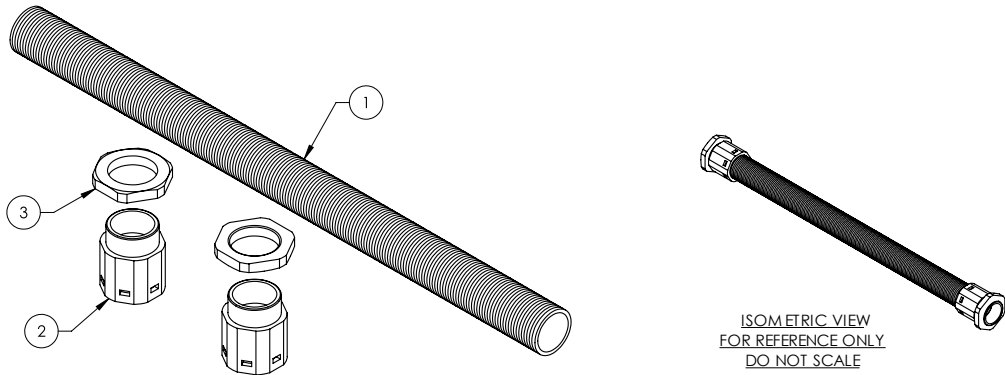

WHERE USED
D4-12 SERIES
FL14 SERIES
HD-14T
HD-7500 SERIES
HD-7W
HD-7P
HD-9 SERIES
HD-973 SERIES
HDS-14 SERIES
HDSO-14 SERIES
HDS-18/27/40 SERIES

- NOTE: UNLESS OTHERWISE SPECIFIED**
- SEE SHIPPING INSTRUCTIONS FOR FINAL PACKAGING
 - SHOWN IN REPRESENTATIONAL FORM ONLY (*)LENGTH FOR REFERENCE ONLY

NEXT ASSEMBLY
5250058 5250175 5250289
5250059 5250184 5250290
5250072 5250191 5250291
5250081 5250187 5250295
5250082 5250188 5250334
5250143 5250189 5250337
5250144 5250191 5250338
5250164 5250193 5250349
5250167 5250194 5250364
5250168 5250195 5250359
5250169 5250228 5250375
5250172 5250266 5250376

ITEM NO	PART NUMBER	DESCRIPTION	QTY	REV
1	5570053	PE FLEX TUBE Ø34.5xØ29	2100mm*	-
2	5555555	WGG1-M36/AD34.5 CONNECTOR	2	-
3	5535050	PLASTIC NUT M36 x 2	2	-

DO NOT SCALE DRAWING	NAME	DATE	BendPak.	
DRAWN	TM	05/05/2022	1645 LEMONWOOD DR. SANTA PAULA, CA 93060	
CHECKED	OR	05/10/2022	TITLE: FLEX TUBE KIT, UP TO 2000mm	
THIRD ANGLE PROJECTION			SIZE	REV
			DWG. NO. A 5216139	A
DIMENSIONS ARE IN MM 			SCALE: 1:3 SHEET 1 OF 1	

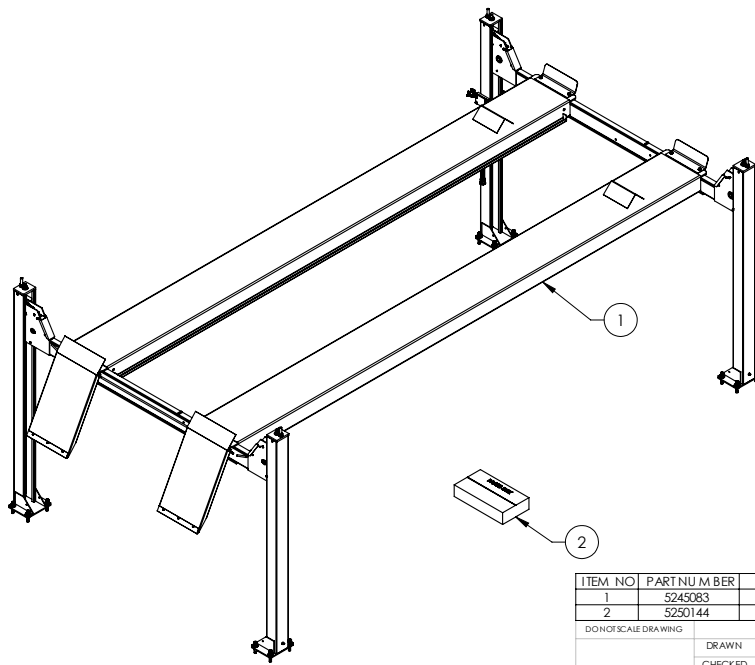

NOTE: UNLESS OTHERWISE SPECIFIED

1. REFER TO MODEL FOR ADDITIONAL INFORMATION
2. SEE SHIPPING INSTRUCTIONS FOR FINAL PACKAGING
3. SEE COLORS & GRAPHICS FOR LABEL PLACEMENT

ITEM NO	PART NUMBER	DESCRIPTION	QTY	REV
1	5245083	HDS-14X LIFT SUPERSTRUCTURE	1	J
2	5250144	HDS-14X PARTS BOX	1	M

DATE	12/05/2019	NAME	CA	DRAWN	CA	CHECKED			
DIMENSIONS ARE IN MM 								TITLE: HDS-14X PRODUCTION LIFT VER D (CE CERT) SIZE: DWG. NO. A 5260599 SCALE: 1:40 SHEET 1 OF 3	

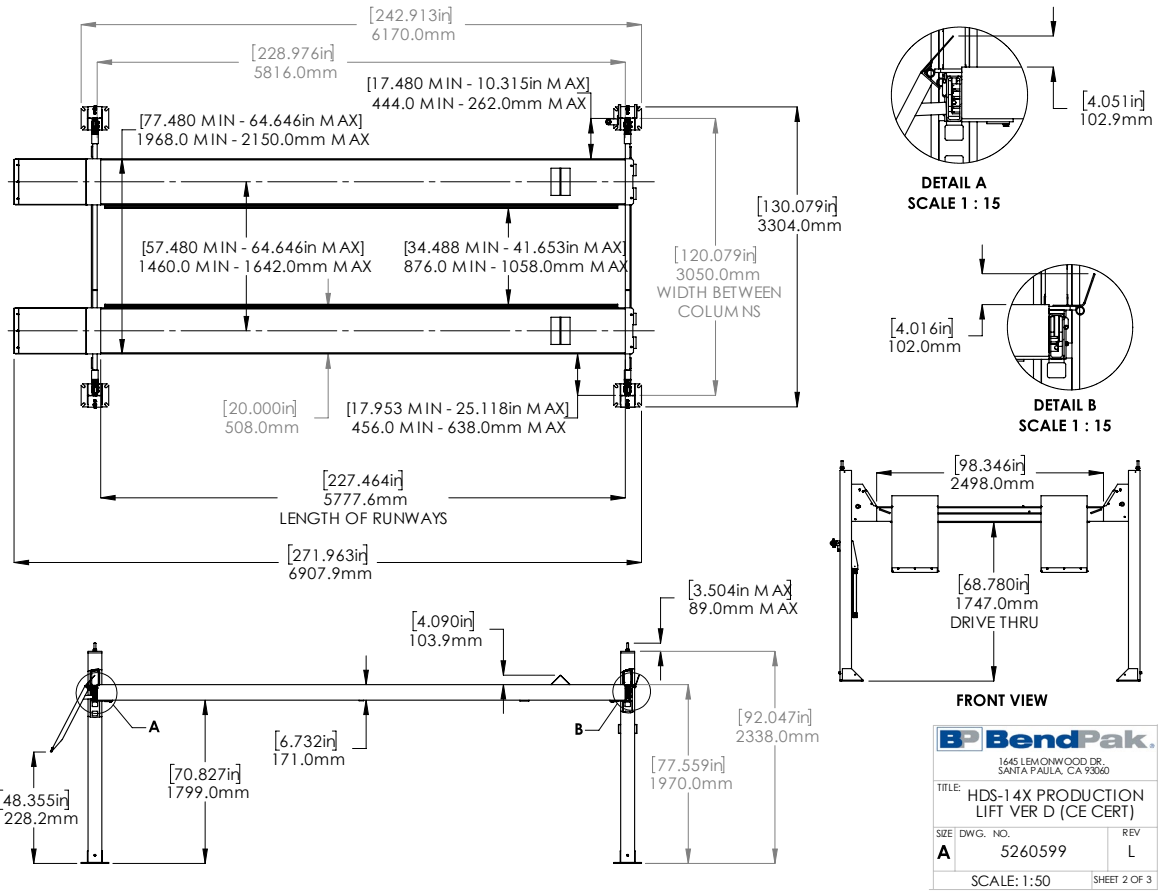

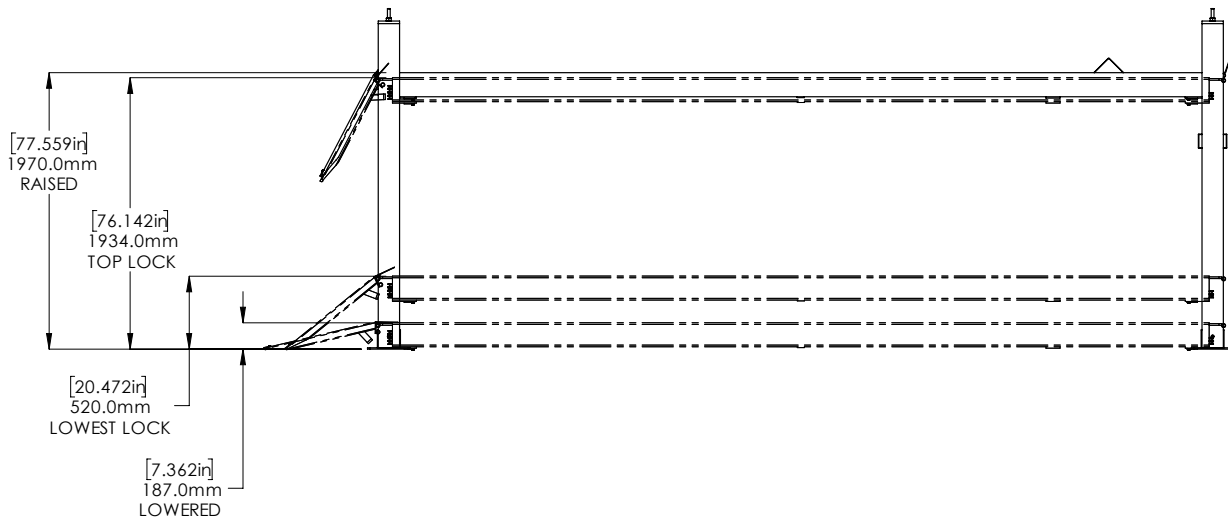

1. DIMENSIONS SHOWN ARE WITH THE LOCK LADDERS ADJUSTED ALL THE WAY UP

BendPak
 1645 LEMONWOOD DR.
 SANTA PAULA, CA 93060

TITLE: HDS-14X PRODUCTION LIFT VER D (CE CERT)

SIZE DWG. NO. 5260599 REV L

SCALE: 1:35 SHEET 3 OF 3

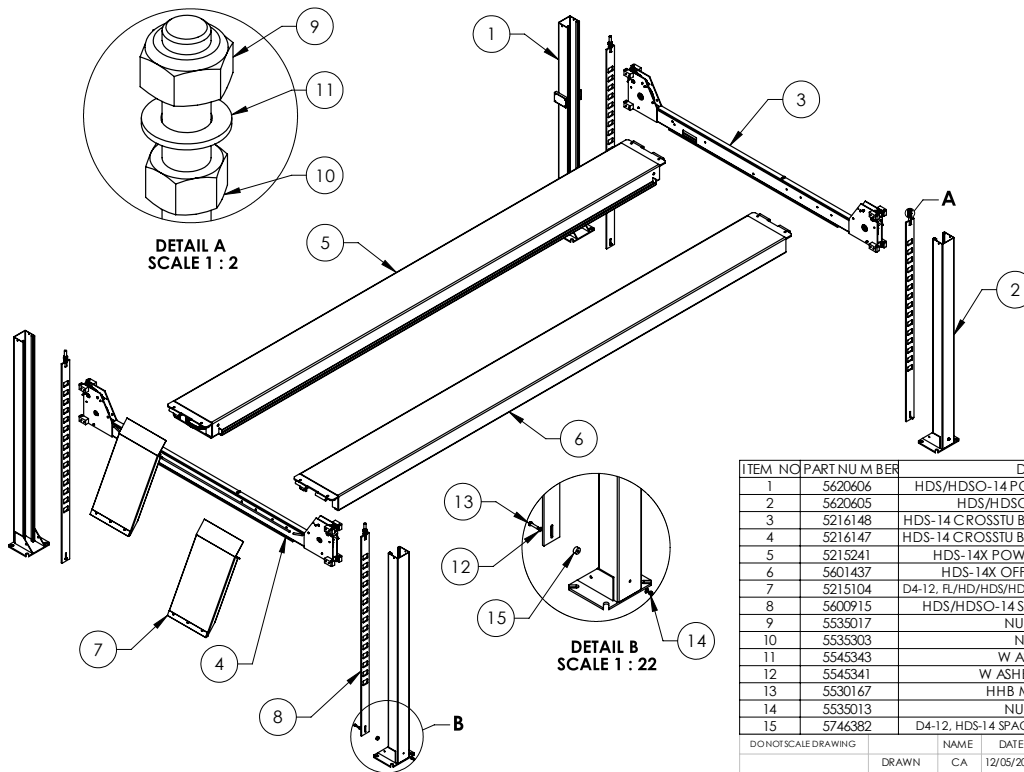

WHERE USED
HDS-14X

NOTE: UNLESS OTHERWISE SPECIFIED

1. REFER TO MODEL FOR ADDITIONAL INFORMATION
2. SEE SHIPPING INSTRUCTIONS FOR FINAL PACKAGING
3. THREAD M 20 HARDWARE ONTO LADDER BOLTS AS SHOWN

NEXT ASSEMBLY
5260599

ITEM NO	PART NUMBER	DESCRIPTION	QTY	REV
1	5620606	HDS/HDSO-14 POWER SIDE POST W ELDMENT	1	C
2	5620605	HDS/HDSO-14 POST W ELDMENT	3	C
3	5216148	HDS-14 CROSS TUBE ASSEMBLY, SMALL WINDOW	1	A
4	5216147	HDS-14 CROSS TUBE ASSEMBLY, LARGE WINDOW	1	A
5	5215241	HDS-14X POWER SIDE RAMP ASSEMBLY	1	V
6	5601437	HDS-14X OFF SIDE RAMP W ELDMENT	1	B
7	5215104	D4-12, FL/HD/HDS/HDSO-14 DRIVE UP RAMP ASSEMBLY	2	K
8	5600915	HDS/HDSO-14 SAFETY LADDER W ELDMENT	4	B
9	5535017	NU T M 20 x 2.5 NL	4	-
10	5535303	NU T M 20 x 2.5	4	-
11	5545343	W ASHER, M 20 FLAT	4	-
12	5545341	W ASHER M 10 x Ø20 FLAT	8	-
13	5530167	HHB M 10 x 1.5 x 45mm	4	-
14	5535013	NU T M 10 x 1.5 NL	4	-
15	5746382	D4-12, HDS-14 SPACER, SAFETY LADDER, 15mm LG	4	A

DO NOT SCALE DRAWING

NAME CA DATE 12/05/2019

BendPak
 1645 LEMONWOOD DR.
 SANTA PAULA, CA 93060

TITLE: HDS-14X LIFT SUPERSTRUCTURE

SIZE DWG. NO. 5245083 REV J

SCALE: 1:45 SHEET 1 OF 1

THIRD ANGLE PROJECTION

PROPRIETARY AND CONFIDENTIAL
 THE INFORMATION CONTAINED HEREIN IS THE PROPERTY OF BENDPAK INC. ANY REPRODUCTION IN PART OR AS A WHOLE WITHOUT THE WRITTEN PERMISSION OF BENDPAK INC IS PROHIBITED.

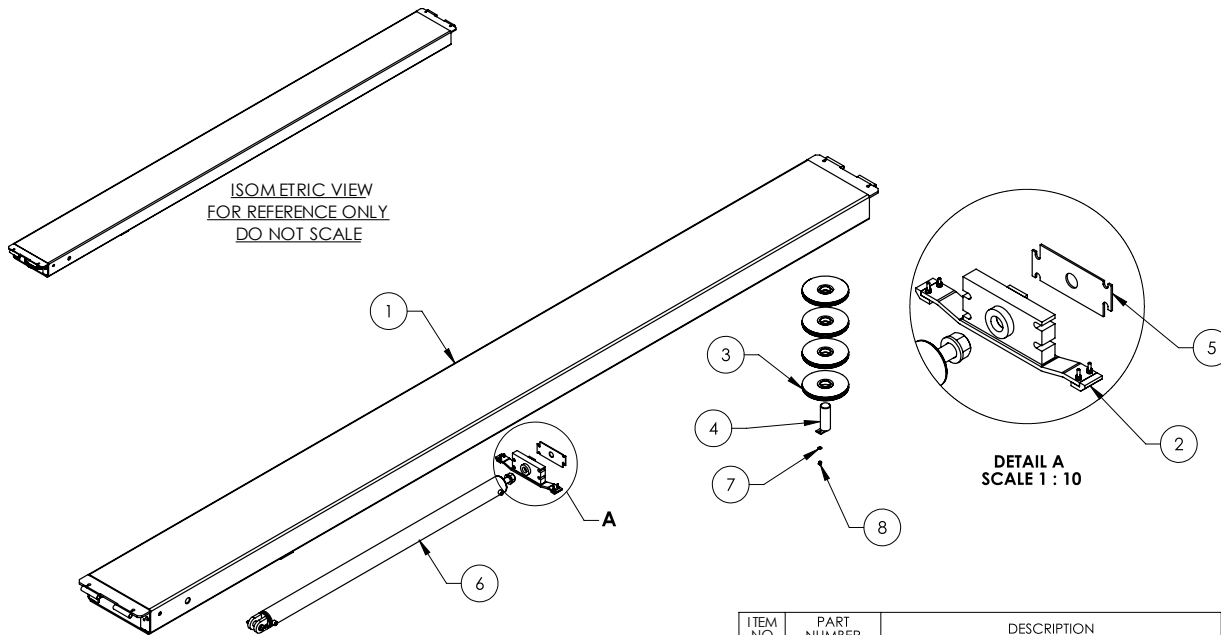

ISOMETRIC VIEW
FOR REFERENCE ONLY
DO NOT SCALE

DETAIL A
SCALE 1 : 10

WHERE USED
HDS-14X

NOTE: UNLESS OTHERWISE SPECIFIED

1. REFER TO MODEL FOR ADDITIONAL INFORMATION
2. VERIFY CYLINDER PORTS ARE CAPPED OFF WITH STEEL 3/8" NPT PLUG
3. SEE SHIPPING INSTRUCTIONS FOR FINAL PACKAGING
4. ASSEMBLE ITEMS AS SHOWN

NEXT ASSEMBLY
5245083

ITEM NO	PART NUMBER	DESCRIPTION	QTY	REV
1	5600268	HDS-14X POWER SIDE RAMP WELDMENT	1	F
2	5215664	HDS/HDSO-14 CYLINDER FLANGE ARM ASSEMBLY	1	C
3	5215015	HDS-14 SERIES RAMP SHEAVE ASSEMBLY	6	C
4	5600260	HDS/HDSO-14 SHEAVE PIN WELDMENT	2	C
5	5736821	HDS-14 CABLE RETAINER PLATE	1	A
6	5502110	CYLINDER ASSEMBLY Ø3.5 x 70	1	L
7	5545341	WASHER M10 x Ø20 FLAT	2	--
8	5530281	HHB M10 x 1.5 x 10	2	--

DO NOT SCALE DRAWING

DRAWN	NAME	DATE
GJZ		11/26/2008

BendPak
1645 LEMONWOOD DR.
SANTA PAULA, CA 93060

CHECKED

TITLE: HDS-14X POWER SIDE RAMP ASSEMBLY

DIMENSIONS ARE IN MM

THIRD ANGLE PROJECTION



SIZE	DWG. NO.	REV
A	5215241	V

SCALE: 1:28

SHEET 1 OF 2

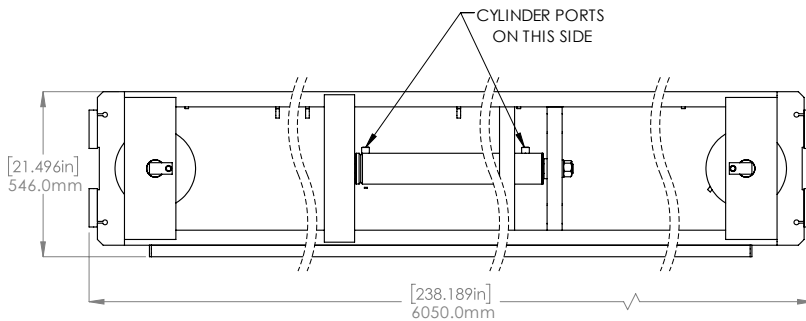
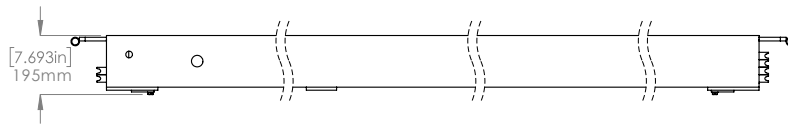

BendPak		
1645 LEMONWOOD DR. SANTA PAULA, CA 93060		
TITLE: HDS-14X POWER SIDE RAMP ASSEMBLY		
SIZE	DWG. NO.	REV
A	5215241	V
SCALE: 1:15		SHEET 2 OF 2

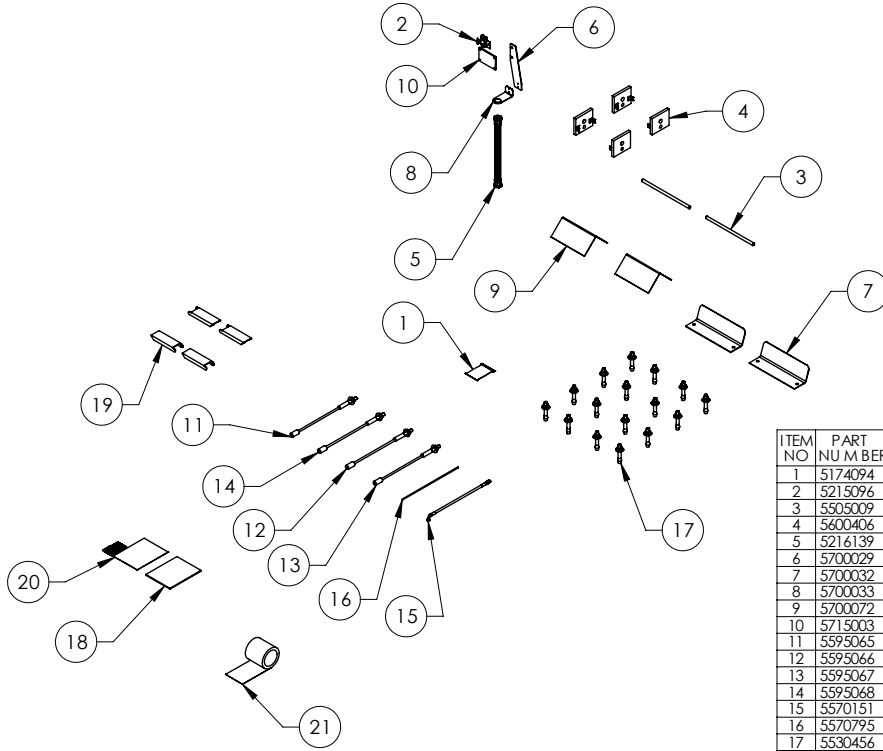

ITEM NO	PART NUMBER	DESCRIPTION	QTY.	RE
1	5174094	D4-12, HD/HDS-14 PARTS BAG	1	C
2	5215096	PUSH BUTTON AIR ASSEMBLY	1	C
3	5505009	D4-12, HD/HDS-14 DRIVE UP PLATFORM PIN	2	C
4	5600406	HD/HDS-14 TOP PLATE W/ELDMENT	4	C
5	5216139	FLEX TUBE KIT, UP TO 2000mm	1	A
6	5700029	HD-SERIES FLEX TUBE BRACKET PLATE	1	F
7	5700032	TIRE STOP	2	C
8	5700033	HD-SERIES FLEX TUBE ANGLE	1	E
9	5700072	WHEEL CHOCK	2	B
10	5715003	POWER UNIT VIBRATION DAMPENER	1	B
11	5595065	HDS/HDSO-14 CABLE ASSEMBLY Ø12 x 4100mm ST	1	E
12	5595066	HDS/HDSO-14 CABLE ASSEMBLY Ø12 x 5732mm ST	1	E
13	5595067	HDS-14X/14LSXE CABLE ASSEMBLY Ø12 x 10076mm ST	1	E
14	5595068	HDS-14X/14LSXE CABLE ASSEMBLY Ø12 x 11751mm ST	1	E
15	5570151	HDS-14X HOSE ASSEMBLY Ø6.4 x 4325mm	1	B
16	5570795	1/4" POLY-FLO TUBING	20000mm*	-
17	5530456	AB 3/4" x 4 - 3/4"	16	-
18	5900161	HDS-14/14X INSTALLATION MANUAL	1	-
19	5716629	HD-14 CROSS TUBE COVER, PLASTIC	4	A
20	5210241	4 POST LIGHT DUTY CEILING PARTS BAG	1	A
21	5930195	ANTI-SLIP TAPE, 6' x 24ft	1	--

WHERE USED
HDS-14X

NOTE: UNLESS OTHERWISE SPECIFIED

- SEE SHIPPING INSTRUCTIONS FOR FINAL PACKAGING
- HOSES AND CABLES IN REPRESENTATIONAL FORM
- (*) LENGTHS FOR REFERENCE ONLY

NEXT ASSEMBLY
5260599

DO NOT SCALE DRAWING

NAME	DATE	
DRAWN TM	05/06/2013	
CHECKED		1645 LEMONWOOD DR. SANTA PAULA, CA 93060

DIMENSIONS ARE IN MM

THIRD ANGLE PROJECTION

PROPRIETARY AND CONFIDENTIAL
THE INFORMATION CONTAINED IN THIS DRAWING IS
THE SOLE PROPERTY OF BENDPAK INC. ANY
REPRODUCTION IN PART OR AS A WHOLE WITHOUT
THE WRITTEN PERMISSION OF BENDPAK INC. IS
PROHIBITED.

TITLE:	HDS-14X PARTS BOX
SIZE:	DWG. NO. 5250144
REV:	M

SCALE: 1:35 SHEET 1 OF

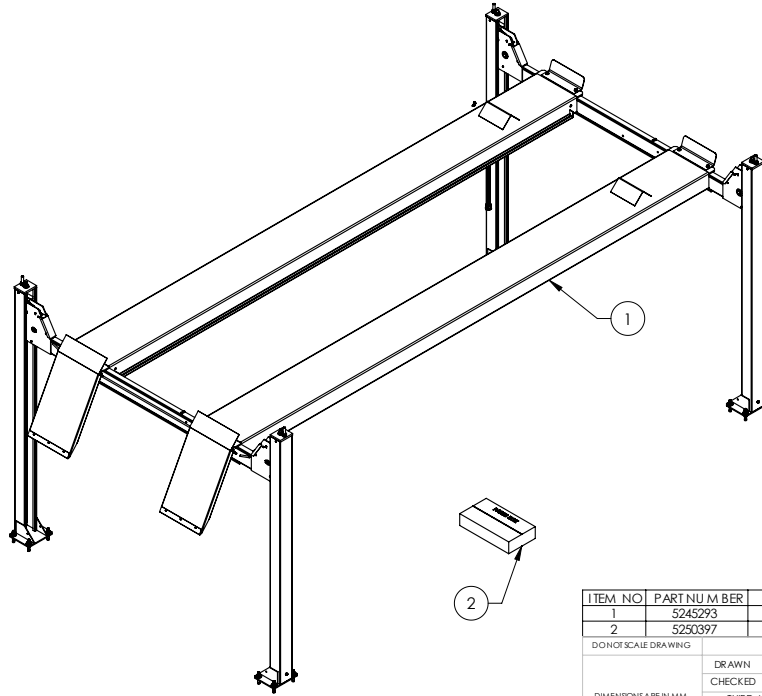

- NOTE: UNLESS OTHERWISE SPECIFIED**
1. REFER TO MODEL FOR ADDITIONAL INFORMATION
 2. SEE COLORS & GRAPHICS FOR LABEL PLACEMENT
 3. SEE SHIPPING INSTRUCTIONS FOR FINAL PACKAGING

ITEM NO	PART NUMBER	DESCRIPTION	QTY	REV
1	5245293	HDS-14XT LIFT STRUCTURE	1	A
2	5250397	HDS-14XT PARTS BOX	1	A

DONOT SCALE DRAWING		NAME	DATE	BP BendPak 30440 AGOURA RD. AGOURA HILLS, CA 91301
DRAWN	TM	02/13/2024		
CHECKED				
DIMENSIONS ARE IN MM		THIRD ANGLE PROJECTION		TITLE: HDS-14XT PRODUCTION LIFT VER A
				SIZE DWG. NO. REV
				A 5260716 A
				SCALE: 1:40 SHEET 1 OF 3

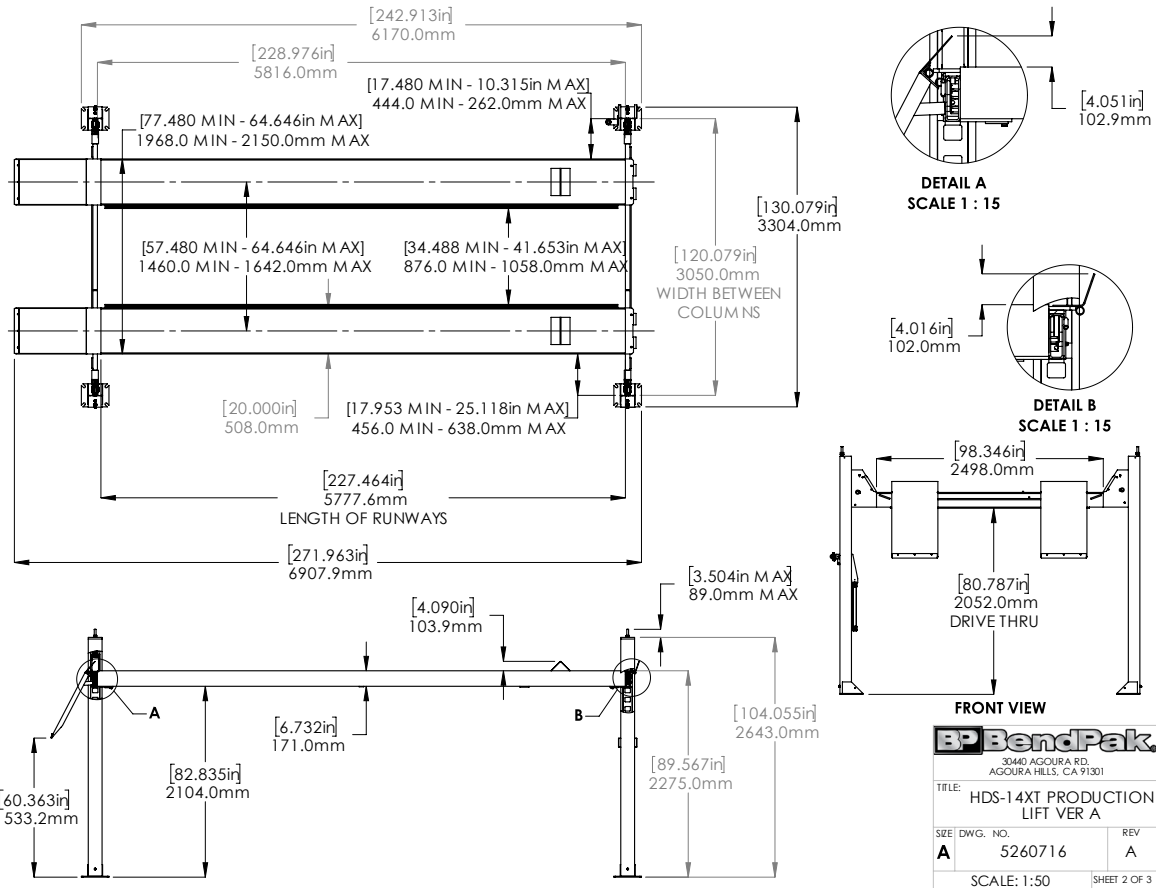

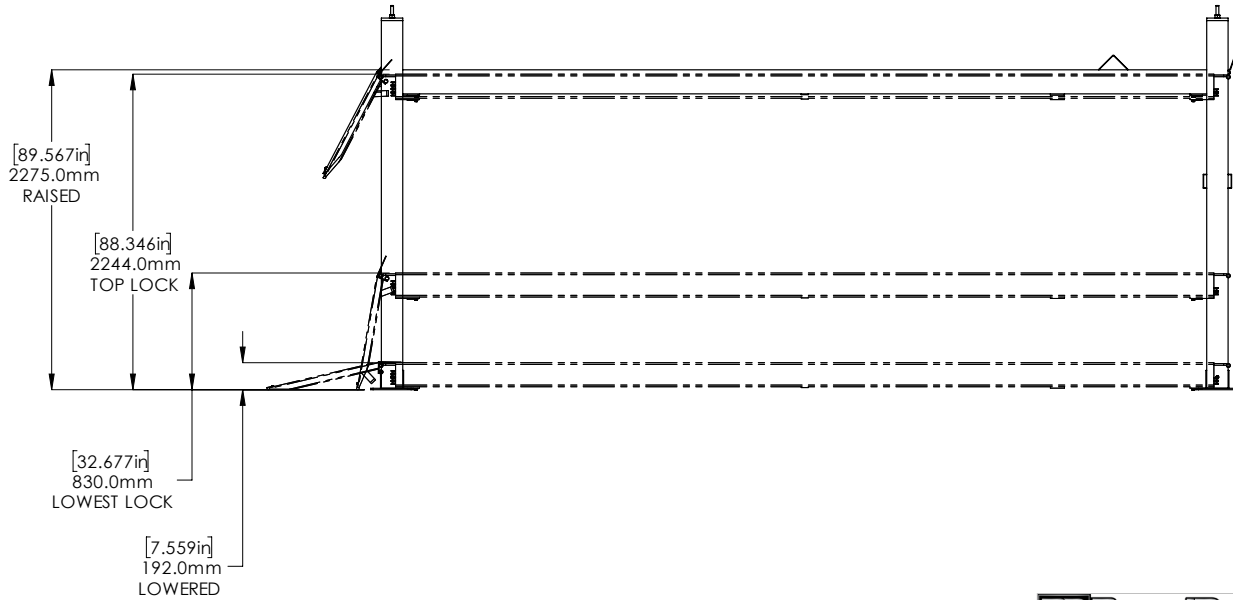

1. DIMENSIONS SHOWN ARE WITH THE LOCK LADDERS ADJUSTED ALL THE WAY UP
2. SAFETY LOCK POSITIONS: 18
3. SPACED EVERY: 101.0mm / 3.976"

BendPak
3040 AGOURA RD.
AGOURA HILLS, CA 91301

TITLE: HDS-14XT PRODUCTION LIFT VER A

SIZE	DWG. NO.	REV
A	5260716	A

SCALE: 1:35 SHEET 3 OF 3

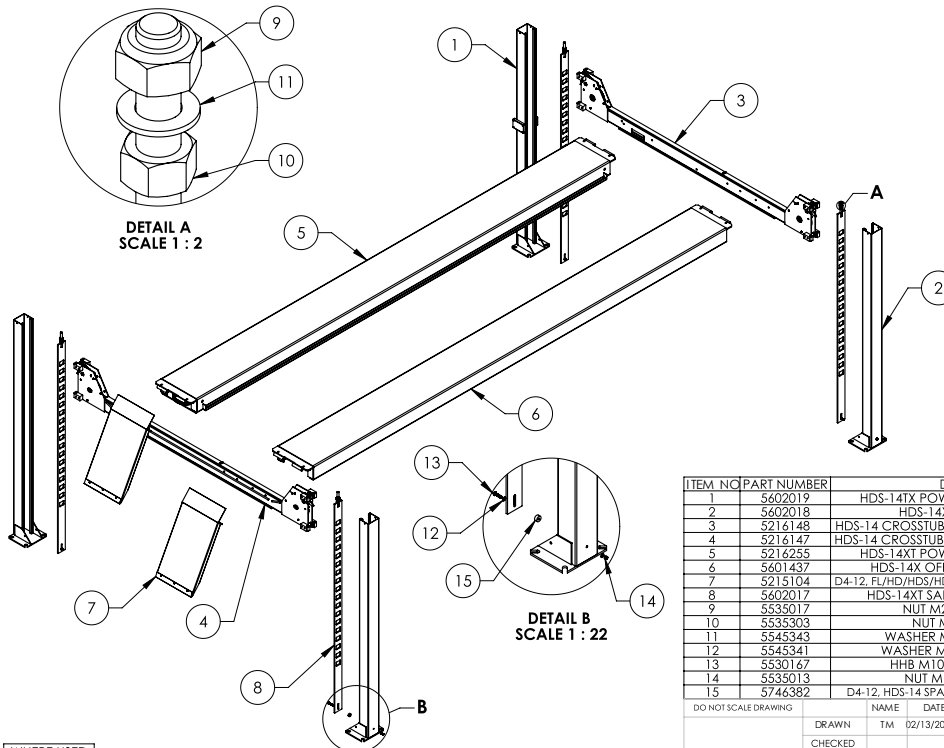

WHERE USED
HDS-14XT

- NOTE: UNLESS OTHERWISE SPECIFIED**
1. REFER TO MODEL FOR ADDITIONAL INFORMATION
 2. SEE SHIPPING INSTRUCTIONS FOR FINAL PACKAGING
 3. THREAD M20 HARDWARE ONTO LADDER BOLTS AS SHOWN

NEXT ASSEMBLY
5260716

ITEM NO	PART NUMBER	DESCRIPTION	QTY	REV
1	5602019	HDS-14TX POWER SIDE POST WELDMENT	1	A
2	5602018	HDS-14XT POST WELDMENT	3	A
3	5216148	HDS-14 CROSSTUBE ASSEMBLY, SMALL WINDOW	1	A
4	5216147	HDS-14 CROSSTUBE ASSEMBLY, LARGE WINDOW	1	A
5	5216255	HDS-14XT POWER SIDE RAMP ASSEMBLY	1	A
6	5601437	HDS-14X OFF SIDE RAMP WELDMENT	1	B
7	5215104	D4-12, FL/HD/HDS/HDSO-14 DRIVE UP RAMP ASSEMBLY	2	K
8	5602017	HDS-14XT SAFETY LADDER WELDMENT	4	A
9	5535017	NUT M20 x 2.5 NL, CL 10.9	4	-
10	5535303	NUT M20 x 2.5, CL 10.9	4	-
11	5545343	WASHER M20 x 37 FLAT, CL 10.9	4	-
12	5545341	WASHER M10 x Ø20 FLAT, CL 10.9	8	-
13	5530167	HHB M10 x 1.5 x 45 FT, CL 10.9	4	-
14	5535013	NUT M10 x 1.5 NL, CL 10.9	4	-
15	5746382	D4-12, HDS-14 SPACER, SAFETY LADDER, 15mm LG	4	A

DO NOT SCALE DRAWING

DRAWN	NAME	DATE
CHECKED	TM	02/13/2024

DIMENSIONS ARE IN MM

THIRD ANGLE PROJECTION

BendPak
3040 AGOURA RD.
AGOURA HILLS, CA 91301

TITLE: HDS-14XT LIFT SUPERSTRUCTURE

SIZE	DWG. NO.	REV
A	5245293	A

SCALE: 1:45 SHEET 1 OF 1

PROPRIETARY AND CONFIDENTIAL
THE INFORMATION CONTAINED IN THIS DRAWING IS THE SOLE PROPERTY OF BENDPAK INC. ANY REPRODUCTION IN PART OR AS A WHOLE WITHOUT THE WRITTEN PERMISSION OF BENDPAK INC. IS PROHIBITED.

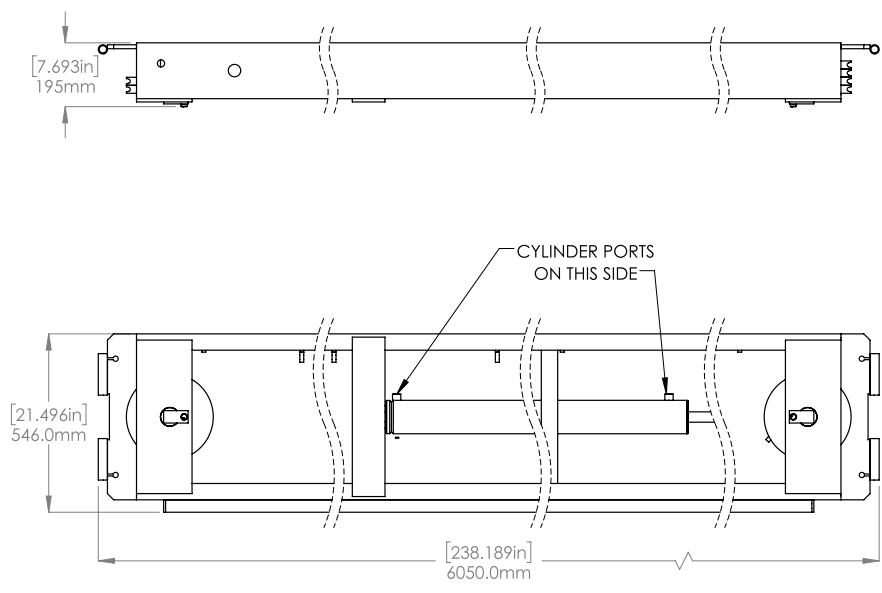
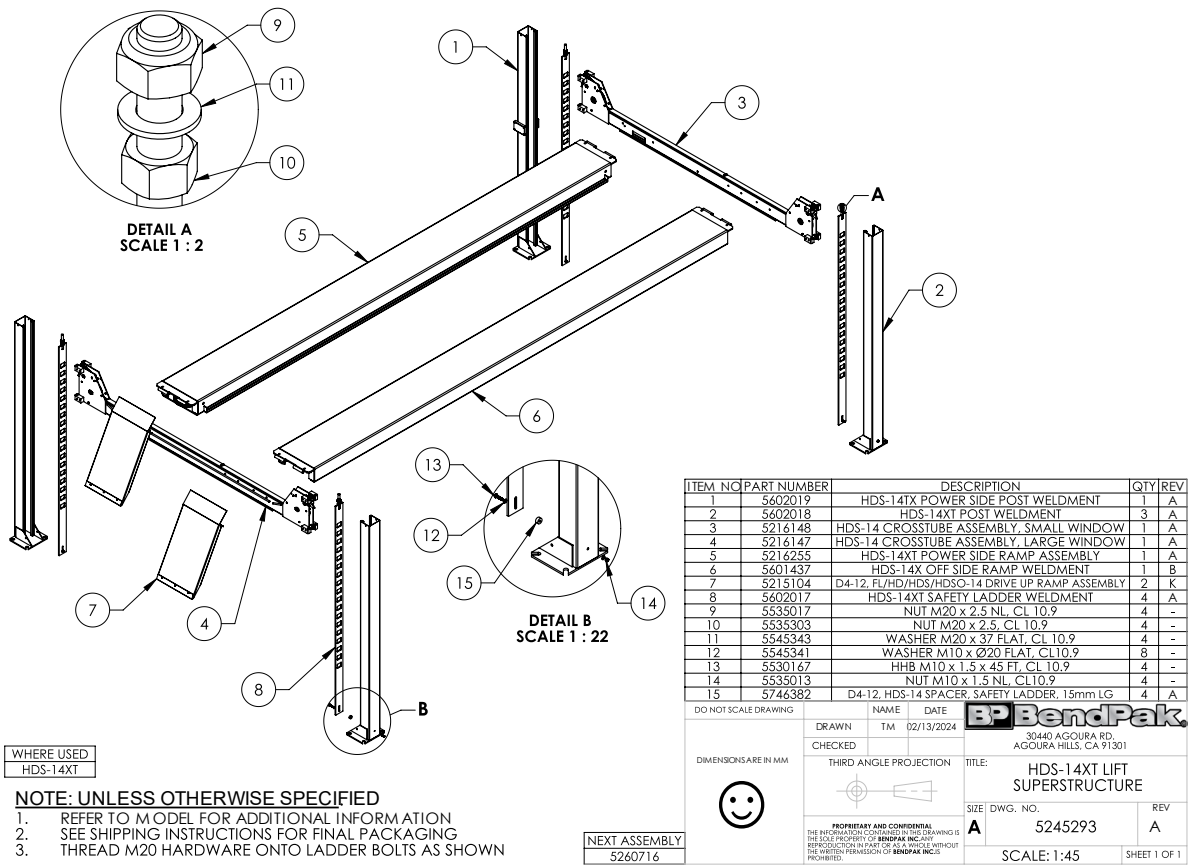

BP BendPak
 30440 AGOURA RD.
 AGOURA HILLS, CA 91301

TITLE: HDS-14XT POWER SIDE RAMP ASSEMBLY

SIZE: A DWG. NO.: 5216255 REV: A

SCALE: 1:15 SHEET 2 OF 2

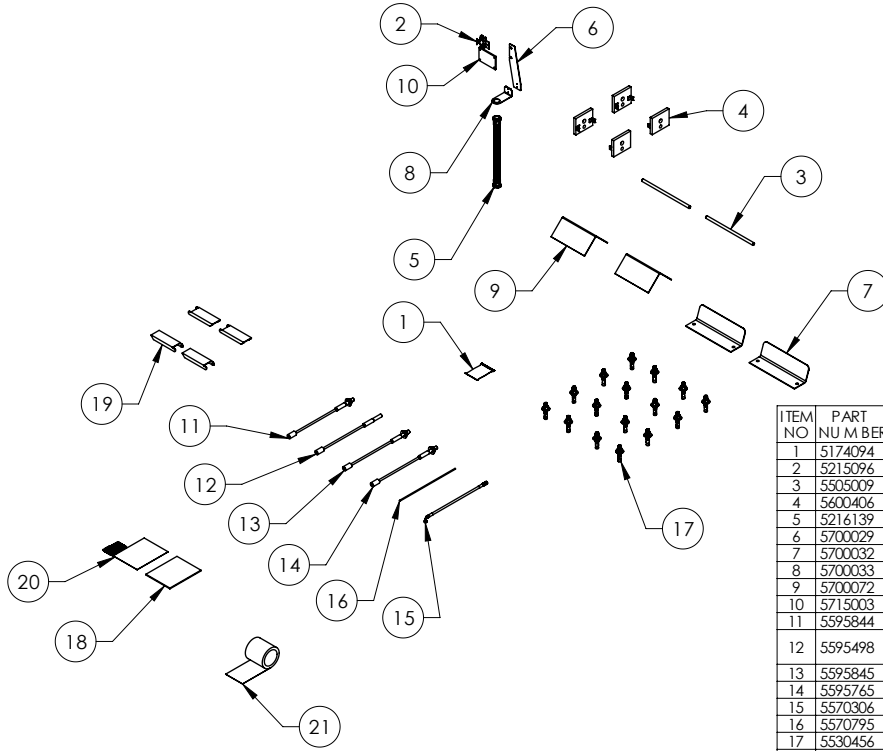

ITEM NO	PART NUMBER	DESCRIPTION	QTY.	RE
1	5174094	D4-12, HD/HDS-14 PARTS BAG	1	C
2	5215096	PUSH BUTTON AIR ASSEMBLY	1	C
3	5505009	FL14/HD/HDS-14 DRIVE UPRAMP PIN	2	D
4	5600406	HD/HDS-14 TOP PLATE WELDMENT	4	C
5	5216139	FLEX TUBE KIT, U.P.T.O 2000mm	1	A
6	5700029	HD-SERIES FLEX TUBE BRACKET PLATE	1	F
7	5700032	TIRE STOP	2	D
8	5700033	FL14/HD/HDS FLEX TUBE ANGLE	1	E
9	5700072	WHEEL CHOCK	2	B
10	5715003	POWER UNIT VIBRATION DAMPENER	1	B
11	5595844	CABLE ASSEMBLY Ø12 x 4405mm ST	1	A
12	5595498	HDS-14 CUSTOM CABLE ASSEMBLY Ø12 x 6037mm ST	1	A
13	5595845	CABLE ASSEMBLY Ø12 x 10381mm ST	1	A
14	5595765	CABLE ASSEMBLY Ø12 x 12065mm ST	1	A
15	5570306	HYDRAULIC HOSE ASSEMBLY Ø6.4 x 4630mm SB	1	A
16	5570795	1/4" POLY-FLO TUBING	20000mm*	-
17	5530456	AB 3/4" x 4 - 3/4"	16	-
18	5900161	HDS-14/14X INSTALLATION MANUAL	1	-
19	5716629	HDS-14 CROSS TUBE COVER, PLASTIC	4	A
20	5210241	4 POST LIGHT DUTY COVER PARTS BAG	1	A
21	5930195	ANTI-SLIP TAPE, 6" x 24ft	1	-

WHERE USED
HDS-14XT

- NOTE: UNLESS OTHERWISE SPECIFIED**
- SEE SHIPPING INSTRUCTIONS FOR FINAL PACKAGING
 - HOSES AND CABLES IN REPRESENTATIONAL FORM
 - (*) LENGTHS FOR REFERENCE ONLY

NEXT ASSEMBLY
5260716

DO NOT SCALE DRAWING

DRAWN	TM	DATE	02/14/2024
CHECKED			

DIMENSIONS ARE IN MM

THIRD ANGLE PROJECTION

PROPRIETARY AND CONFIDENTIAL
THE INFORMATION CONTAINED IN THIS DRAWING IS THE SOLE PROPERTY OF BENDPAK INC. ANY REPRODUCTION IN PART OR AS A WHOLE WITHOUT THE WRITTEN PERMISSION OF BENDPAK INC. IS PROHIBITED.

BendPak
30440 AGOURA RD.
AGOURA HILLS, CA 91301

TITLE: HDS-14XT PARTS BOX

SIZE DWG. NO. A 5250397

REV A

SCALE: 1:35 SHEET 1 OF 1

Certificate of Conformity



EC Type-Examination Certificate

(Fm 210-017, Rev.10)



For the requirements of the Machinery Directive 2006/42/EC
For Annex IV machinery

Certificate No.: CE-C-20120209-01-03-5B
Date of first issue: 2014.01.27
Date of last review: 2019.01.27
Date of next review: 2024.01.26

NAME AND ADDRESS OF THE MANUFACTURER: Bendpak Inc.
1645 E. Lemonwood Drive, Santa Paula, CA, United States of America

PRODUCT DESCRIPTION/ TYPE AND MODEL: 4 Post Vehicle Servicing Lifts 14000lb (6350kg) Capacity
HDS-14 130W x 241L x 70H in
HDS-14X 130W x 271L x 70H in

APPLICABLE STANDARDS: EN1493:2010 Vehicle Lifts
EN 60204-1:2006+A1:2009 Safety of machinery - Electrical equipment of machines - Part1:General requirements

A COPY IS AVAILABLE FROM: CCQS UK Ltd., 5 Harbour Exchange, London, E14 9GE, UK

SUBJECT TO THESE CONDITIONS: A Rolling Jack is not included in this certification.

RE-ISSUE HISTORY
CE-C-20120209-01-03-5A first issue
CE-C-20120209-01-03-5B this issue – Review of original certification

The technical file, accompanying documentation and the equipment which they describe have been found to be in compliance with the requirements of the Machinery Directive 2006/42/EC.

The responsible person defined above has responsibility for ensuring that all future serial manufacture of the machinery conforms to the sample submitted for EC type-examination referenced above.

Any changes to the design of the machinery certified here must be advised to CCQS UK Ltd. for re-assessment.

A CE marking should not be fixed to the equipment until the requirements of all relevant directives have been met.

Approved by: Owen Bian – Office Manager

Date: 2019.01.27

Appointed by UK Government
as a Notified Body
for CE Marking No. 1105

CCQS UK Ltd.,
5 Harbour Exchange, Canary Wharf,
London, E14 9GE, UK
Tel: +44 (0) 20 7868 1509
Email info@ccqs.co.uk

If in any doubt about the integrity of this certificate,
please verify it on our website at
<http://www.ccqs.co.uk>



Automotive Lift Institute (ALI) Store

You probably checked the [ALI's Directory of Certified Lifts](http://www.autolift.org/ali-directory-of-certified-lifts/) (www.autolift.org/ali-directory-of-certified-lifts/) before making your most recent Lift purchase, but did you know the **ALI Store** (www.autolift.org/ali-store/) offers a wide variety of professional, easy-to-use, and reasonably priced training and safety materials that will make your garage a safer place to work?

To find a Certified Lift Inspector in your local area, visit [Directory of ALI Certified Lift Inspection Providers](http://www.autolift.org/find-a-certified-auto-lift-inspector/) (www.autolift.org/find-a-certified-auto-lift-inspector/).

The ALI Store is your trusted source for workplace safety!



Lifting It Right Online Certificate Course. Make *sure* you and your people are lifting vehicles the right way.



ALI Lift Inspector Certification Program Registration. Become a ALI Certified Lift Inspector.

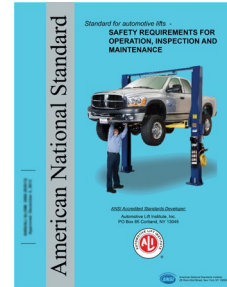

ANSI/ALI ALOIM Standard for Automotive Lifts. Safety Requirements for Operation, Inspection, and Maintenance.

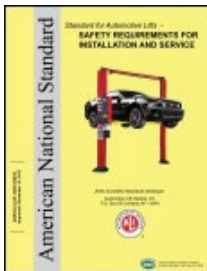

ANSI/ALI ALIS Standard. Safety Requirements for Installation and Service.

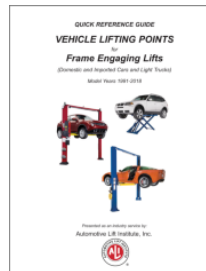

Guide to Hitting Vehicle Lifting Points for Frame-Engaging Lifts. Don't eyeball your lifting points, *know* where they are.



Lift Operator Safety Materials. Five safety documents in a single package.

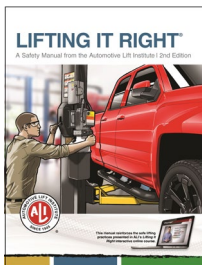

Lifting It Right. A hardcopy version of the *Lifting It Right* safety manual from the Automotive Lift Institute.



Uniform Warning Labels and Placards for 2-Posts. Labels in Mandarin, French Canadian, and Spanish are also available.



Safety Tips Card. Reminds your people of 13 key safety tips to follow daily.

Visit today and get the training and materials you need to work safely:
<http://www.autolift.org/ali-store/>