

I979600 REV. A



A Division of Conbraco Industries, Inc. Matthews, NC Pageland, SC Conway, SC

2 PIECE THREADED STEEL BALL VALVES WITH SPRING RETURN INSTALLATION, OPERATION, & MAINTENANCE GUIDE 76-500/89-500 Series

INSTALLATION

Two piece threaded end Apollo Ball valves are bi-directional. They may be installed in vertical or horizontal pipe runs without regard to flow direction and without regard to stem orientation.

Note: Valves must be installed in piping systems that comply with the applicable portions of the ASME B31 standards. Special considerations must be taken with respect to pipe line expansions and contractions and the media expansion and contractions within the piping system.

Pipe connections to be threaded into these valves should be accurately threaded, clean and free of foreign material or metal shavings. PTFE pipe tape is recommended for use as the pipe joint sealant. Two wrenches must be used when making up pipe joints to these valves. Apply one wrench on the valve end closest to the pipe joint being tightened and the other wrench to the pipe to prevent transmitting torque through the valve body joint. Typical pipe make-up is 1-1/2 turns after installing the pipe hand-tight.

MAINTENANCE

Regular Maintenance

Normal stem packing wear can be compensated for by tightening the packing gland screw. (Wrench part number H371400 is available to ease this operation.) Tighten the packing gland screw clockwise in 1/8 turn increments until observed leakage stops. Do not exceed the values shown in Table 1. If all of the adjustments to the packing gland screw have been made, remove the handle assembly as described in steps 1-6 below. Remove packing gland screw and add one or two replacements bearings on top of the old packing. Reinstall the handle and handle nut.

Caution: Do not disassemble valve while under pressure nor with entrapped hazardous fluids therein.

Valve Repair

Disassembly

- 1) Operate the valve fully opened to fully closed to assure there are no trapped fluids or pressure in the body cavity. Leave the valve in the closed position.
- 2) Remove handle extension. Clean and set aside for reuse.

- 3) Remove the two hex jam nuts and the washer. Then remove the nyloc hex nut and spring.
- 4) Remove anchor screw then remove spring rod from the spring return handle adapter.
- 5) Remove stem nut and spring return handle adapter.
- 6) Install pipe plugs in the body and retainer ports of NPT valves to prevent collapsing those areas.
- 7) Remove the retainer from the body. It may be necessary to heat the body joint above 450°F to breakdown the sealant used to secure the valve halves.
- 8) Remove the ball from the body cavity and inspect. The ball must be smooth and without pits, burrs or scratches.
- 9) Remove packing gland and push the stem from the outside into the body cavity and remove.
- 10) Remove all seals and seats from the body, stem and retainer then discard.

Re-Assembly

- 1) Install stem bearing on to stem.
- 2) Fit stem into body from the retainer end and position the stem with the handle flats perpendicular to the flow axis.
- 3) Install stem packing over stem and fit into body recess.
- 4) Install packing gland screw into the threaded stem area.
- 5) Tighten the gland screw to manufacturing torque specifications: *Tightened to the torque values shown in Table 1.*
- 6) Apply suitable light lubricant to seat and fit into the seat pocket of the body.
- 7) Install the ball in the closed position interlocking with stem.
- 8) Apply suitable light lubricant to seat and fit into the seat pocket of the retainer.
- 9) Apply an adequate amount of thread sealant compound (Loctite® 609, 648 or 680) to the retainer threads so that it covers no less than two complete threads opposite of the retainer shoulder.
- 10) With the ball in the closed position, thread the retainer into the body and torque to manufacturing specification to secure the body joint. Tighten to the torque values shown in the table 1.
- 11) Apply thread locking compound to each socket head screw. Attach the anchor base using the two socket head screw.
- 12) Apply two drops of thread lock compound to the stem nut and attach spring return handle adapter to the stem.
- 13) Insert spring rod assembly thru the hole in the spring return handle adapter. Verify rod tip orientation as noted * in drawing. Apply thread lock compound to the anchor screw and attach the rod assembly to the anchor base.
- 14) Place spring over rod assembly and into the threaded hole of the spring return handle adapter. Slide the washer into place and secure with the nyloc hex nut. Tighten the nyloc nut to achieve dimension "A" shown in table. Assemble the other washer and two hex jam nuts at the end of the rod as shown in parts illustration and apply two drops of thread lock compound.
- 15) Place handle extension over spring assembly and apply two drops of thread sealant to the threads. Tighten the handle extension into the spring return handle adapter.
- 16) Cycle the valve to the open position and verify proper operation and alignment of handle and/or mechanism.

Warning: Be sure extremities are free of flow path to prevent bodily harm.

Table 1: Torque Requirements

Valve Size	Gland Screw Torque (+ or - 10%)	Retainer Torque (+ or - 10%) (ft-lb)
1/4" - 3/8"	10-12	13
1/2"	10-12	16
3/4"	15 - 20	42
1"	15 - 20	63
1-1/4"	35 - 40	130
1-1/2"	35 - 40	199
2"	35 - 40	282

Table 2: "A" Height Requirements

Valve Size	A - Approx.
1/4", 3/8", 1/2"	1-5/8"
3/4", 1"	7/8"
1-1/4" - 2"	1-7/8"

PARTS ILLUSTRATION

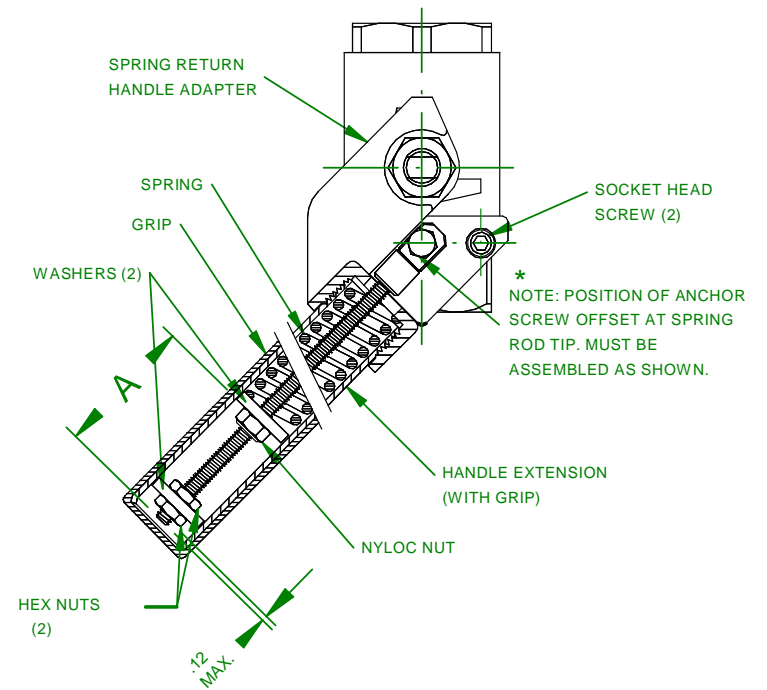
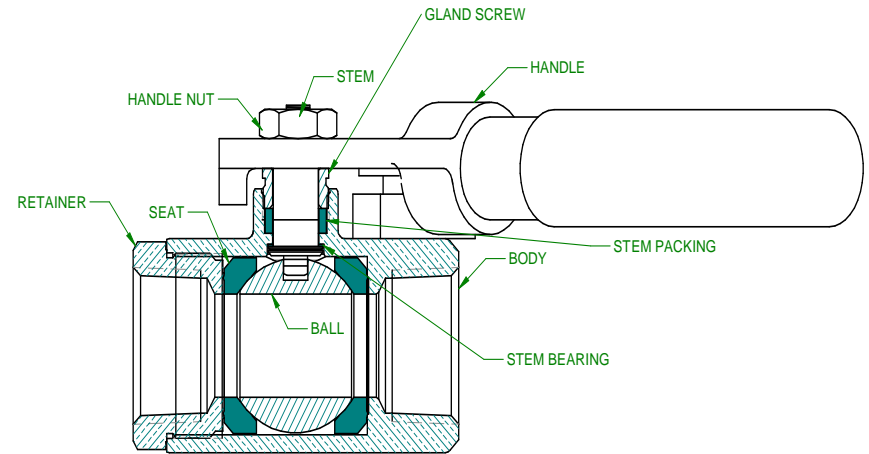

Amendment Register

Date	ECN	Revision	Page	Description	Initiator	Reviewed
8/28/2014	M14578	A	1-2	Released	TH	GDG