

Building connections that last™



Gruvlok® Roll Groover

3006 & 3006C Manual



For over 160 years, Anvil has worked diligently to build a strong, vibrant tradition of making connections — pipe to pipe and people to people.



We pride ourselves in providing the finest quality pipe products and services with integrity and dedication to superior customer service at all levels.



We provide expertise and product solutions for a wide range of applications, from plumbing and mechanical, HVAC, industrial and fire protection to mining, and oil and gas. Our comprehensive line of products includes: grooved pipe couplings, grooved and plain-end fittings, valves, cast and malleable iron fittings, forged steel fittings, steel pipe nipples and couplings, pipe hangers and supports, channel and strut fittings, mining and oil field fittings, along with much more.

As an additional benefit to our customers, Anvil offers a complete and comprehensive Design Services Analysis for mechanical equipment rooms, to help you determine the most effective and cost-efficient piping solutions for your pipe system.



At Anvil, we believe that responsive and accessible customer support is what makes the difference between simply delivering products — and delivering solutions.

BUILDING CONNECTIONS THAT LAST



SAFETY INSTRUCTIONS	04
GROOVER DESCRIPTION	05
INSTALLING SUPPORT LEG ASSEMBLY	06
PIPE SET-UP AND POSITIONING	07
SETTING GROOVE DIAMETER	08
GROOVING IPS STEEL PIPE	09
GROOVING CTS COPPER SYSTEM	10
GROOVING ROLL CHANGE	11
GROOVER MAINTENANCE	13
REPLACEMENT PARTS	14
GROOVE SPECIFICATIONS	15
TROUBLESHOOTING	17

IMPORTANT SAFETY NOTICE



Carefully read and understand instructions before assembling and operating the Groover(s). Become thoroughly familiar with the Groover operation, usage and possible hazards specific to the Groover(s).



THE GRUVLOK® MODEL 3006/3006C ROLL GROOVERS ARE TO BE USED ONLY FOR ROLL GROOVING OF PIPE.

These operating instructions provide important information for the safe operation of the Groover to protect the operator from possible, serious injury. The Groover is designed for safe, reliable operation. However, unforeseen circumstances, impossible to predict, could result in an accident. Following the information in these operating instructions will permit safe operation of the Groover.

SAFETY INSTRUCTIONS

A. GENERAL

1. Carefully read and understand these operating instructions before assembling and operating the Groover.
2. Read and follow the safety labels on the Groover.
3. Understand the function and the location of all power and grooving controls before using the Groover.

B. OPERATOR SAFETY

1. Do not wear loose clothing, loose sleeve cuffs, loose fitting gloves, or jewelry that could get caught in moving parts.
2. Wear safety glasses and safety shoes.
3. Tie-up or cover long hair.
4. Wear ear protection if using the Groover in a high noise area or for prolonged periods of grooving.
5. Do not operate the Groover if you are tired from fatigue or medication.
6. Do not allow horseplay around the Groover.

C. GROOVER SET-UP

1. Provide a safe work area. Keep the work area well lighted and maintain a clear, uncluttered space for operation of the Groover.
2. **Do not use the Groover in wet or damp locations.**
The floor area around the Groover must be dry and free of slippery materials.
3. Set-up the Groover on firm, level ground. Do not locate the Groover on sloped or irregular ground conditions.
4. Remove all tools, wrenches, etc., from the Groover and power drive base before applying power to the Groover.
5. **Do not attempt to lift the Groover by yourself.**
6. Use the Model 3006/3006C Groover only with a Ridgid® 300 Power Drive with 38 RPM operation.
7. The Model 3006/3006C Groover must be properly mounted on the Ridgid 300 support arms and the Groover driveshaft firmly tightened into the Ridgid 300 chuck jaws.
8. Unplug the Ridgid 300 drive power cord prior to servicing or changing groover parts.

D. GROOVER OPERATION

1. All safety guards must be in place. Never operate the Groover with the guards removed.
2. Do not operate the Groover without a foot switch. A foot switch is required for safe operation of the Groover.
3. Operate the Groover only from the pump side of the Groover.
4. Keep hands away from guide and grooving rolls. The Groover is designed for "hands clear" grooving.
5. Maintain balanced footing keeping the foot switch within comfortable reach. Do not reach across the Groover or pipe. Keep hands and clothing away from all moving parts.
6. Do not place excessive force on the hydraulic pump handle. Follow grooving instructions for safe Groover operation.
7. Provide support for piping spool pieces through the use of an appropriate pipe stand properly fastened to the floor or ground.
8. Use the Groover only for the size and wall thickness pipe for which it was designed.
9. Do not operate the Groover if any part of the Groover is damaged or broken.
10. Do not attempt to groove pipe shorter than 5" in length.
11. Keep all visitors and bystanders at a safe distance from the Groover, pipe and power cords.

E. ELECTRICAL SAFETY

1. The Ridgid® 300 Power Drive should be connected to an integrally grounded electrical system protected by a Ground Fault Current Interrupter (GFCI).
2. Never use worn or damaged cords.

GROOVER DESCRIPTION

A. 3006 STANDARD EQUIPMENT

Roll Groover complete with Adjustable Support Leg Assembly and roller sets for grooving 2"-6" and 8"-12" steel pipe, Steel/CTS Dual Guide Roll Assembly, hydraulic pump with pressure gauge, and two depth adjustment gauges. This unit is designed for direct attachment to your Ridgid® 300 Power Drive. Complete with comprehensive setup, operating and troubleshooting instructions.

Shipped in a reusable wooden storage crate.

Approximate shipping weight: 225 pounds.

Required Ridgid® 300 Power Drive not included.

B. 3006 OPTIONAL EQUIPMENT

CTS COPPER SYSTEM:

- 2" - 8" CTS Copper System Grooving Rolls, 2" - 4" CTS Depth Gauge, and 5" - 8" CTS Depth Gauge.

A. 3006C STANDARD EQUIPMENT

Roll Groover complete with Adjustable Support Leg Assembly and CTS Copper System roller set for grooving 2"-6" copper tube, CTS Guide Roll Assembly, hydraulic pump with pressure gauge, and 2"-6" Universal Diameter Gauge. This unit is designed for direct attachment to your Ridgid® 300 Power Drive. Complete with comprehensive setup, operating and troubleshooting instructions.

Shipped in a reusable wooden storage crate.

Approximate shipping weight: 215 pounds.

Required Ridgid® 300 Power drive not included.

B. 3006C OPTIONAL EQUIPMENT

STEEL OPTION:

- Consisting of 2"-6" and 8"-12" roll sets, Steel/CTS Dual Guide Roll Assembly, and two depth adjustment gauges

Note: See Section XI for further details of parts for the 3006 and 3006C Roll Groover.

C. 3006/3006C GROOVER CAPABILITY

GROOVER CAPABILITY										
Pipe Material	Pipe Size/Wall Thickness (Schedule) ^{1,2}									
In.	2	2 ½	3	4	5	6	8	10	12	
DN(mm)	50	65	80	100	125	250	200	250	300	
Steel	Schedule 10, 40								0.188"	0.219"
Stainless Steel	Schedule 10S, 40S									
Copper	K, L, M & DWV									

1. All wall thicknesses shown are the maximum wall thicknesses for the indicated pipe material.
2. Minimum wall thickness for each pipe material and size is:
 Steel: 2"-12" Schedule 10
 Stainless Steel: 2"- 12" Schedule 10S, 40S
 Copper: 2"- 2 ½" - Type M
 3"- 8" - Type DWV
3. Please contact an Anvil Representative for information on grooving alternate materials and wall thickness.

D. GROOVING TIMES

This chart shows approximate grooving times with the groover set-up for the proper size and groove diameter and the pipe properly positioned on the groover. The times shown are average times from the start of rotation of the pipe in the grooving rolls to completed groove.

MODEL 3006/3006C STEEL PIPE GROOVING TIMES (MINUTES: SECONDS)									
Pipe Size (In./DN(mm))/Max Steel Pipe Wall Thickness									
2	2 ½	3	4	5	6	8	10	12	
50	65	80	100	125	150	200	250	300	
0:20	0:20	0:25	0:30	1:00	1:20	1:35	1:50	2:20	

“RIDGID” is a registered trade mark of Emerson Electric Company.



Removal of the Groover from the wooden crate and mounting of the Groover to the Ridgid® 300 drive should be accomplished by 2 persons. To avoid possible injury DO NOT ATTEMPT TO LIFT THE FIGURE 3006/3006C ROLL GROOVERS WITH LESS THAN TWO PEOPLE .

INSTALLING SUPPORT LEG ASSEMBLY

Use the Adjustable Support Leg Assembly for the 3006/3006C Roll Groover whenever long pieces of pipe/tubing or heavier wall thicknesses are being grooved.

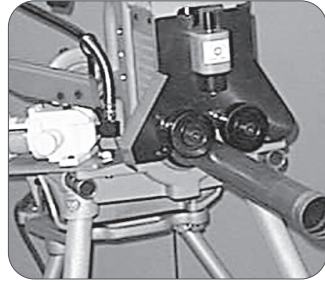

1. Slide round tubing over left support arm of Ridgid® 300 tool so that flat plate is under both arms. Push tubing back as far as allowed on the arms.
2. Insert each lower leg (with feet) into each upper leg so that they overlap by approximately 12 inches. Hand tighten the hex head bolts to temporarily hold in place.
3. Starting with the right leg, insert each upper leg into socket under the flat plate. Loosen the hex bolt holding the lower leg and adjust so that the feet are pointing out from the Ridgid® 300 tool. Repeat with left leg. Tighten the hex bolts on the upper leg and socket to lock legs in place. ($\frac{9}{16}$ " wrench) Base should look like assembled picture.
4. Slide 3006/3006C tool onto Ridgid® 300 Tool as described in Section IV. Back of tool should sit over flat plate with sockets underneath.

GROOVER SET-UP MODEL 3006/3006C

The gruvlok® model 3006/3006c roll groovers are designed for use with a ridgid® 300 power drive

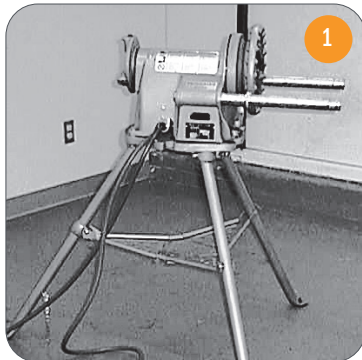

1. Extend the mounting arms of the Ridgid® 300 power drive, approximately 12" out from the body of the drive.

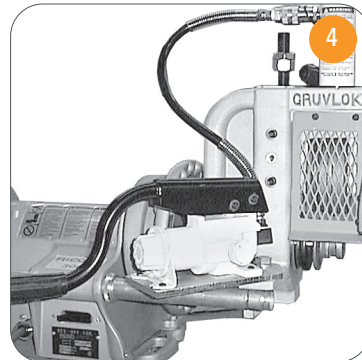

4. Align the flats on the triangular shaft tailpiece with the Ridgid® 300 chuck jaws and slide the Groover back into the chuck jaws. Securely tighten the chuck jaws.

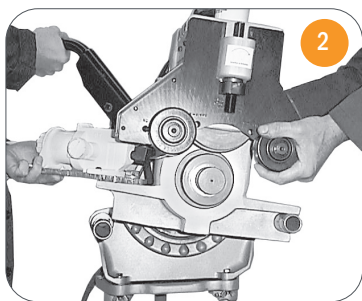

2. Grasp the Groover base on opposite sides, lift the Groover out of the shipping box and place the mounting wings in the Groover base over the extended mounting arms.



5. Push extension arms in flush with the groover mounting base front.

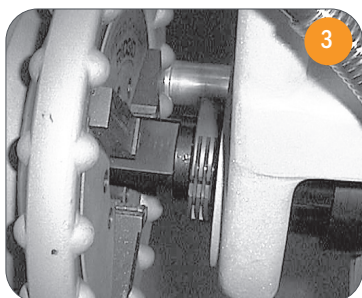

3. Align the flats on the triangular shaft tailpiece with the Ridgid® 300 chuck jaws and slide the Groover back into the chuck jaws. Securely tighten the chuck jaws.

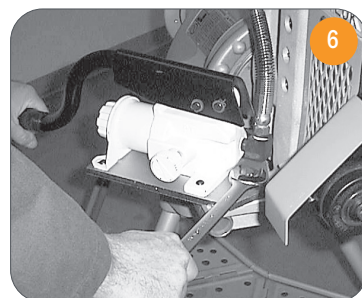

6. Position the pump to the desired position for ease of operation. Tighten bolt to lock pump in position or if desired, back off just slightly to permit pump to be oriented by operator to most comfortable position during Groover operation. ($\frac{15}{16}$ " wrench)

PIPE SET-UP & POSITIONING

The Model 3006 Groover comes with 2" -6" Steel grooving rolls installed unless otherwise requested on your order. The Model 3006C Groover comes with 2" -6" CTS Copper grooving rolls installed. To change grooving rolls for other sizes, for copper tubing, or for steel pipe, refer to page 13 for grooving rolls and guide roll plate changeout.

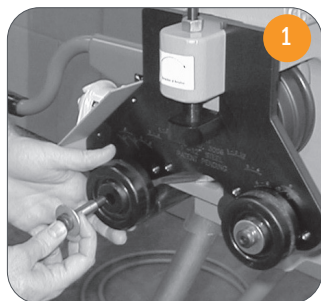

1 Set both rubber guide rolls located on the front of the Groover, into the correct holes for the size pipe being grooved. (1/4" allen wrench)

Note: For CTS Copper System, use the Steel/CTS Dual Guide Roll Assembly.

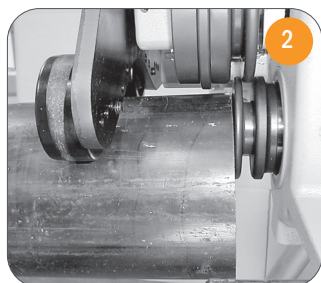

2 Insert pipe over the bottom roll (groove roll) positioning the pipe flush against the front flange of the bottom roll.

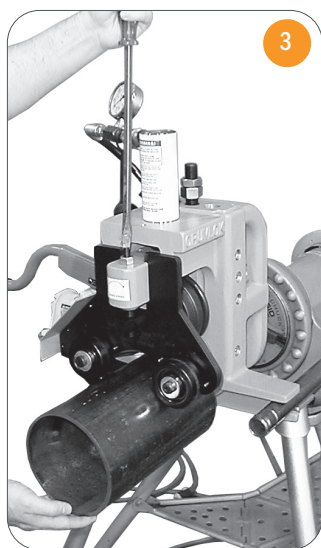

3 Using the slot on top of the roller plate adjustment rod, raise (counterclockwise rotation) the guide roll mounting plate sufficiently to ensure that the top grooving roll makes contact with the pipe prior to guide roll contact.

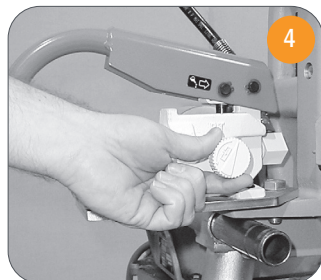

4 Close the release valve on the hydraulic pump by turning the knob clockwise. Pump the hydraulic hand pump to lower the top grooving roll into light firm contact (approx. 100 psi) with the pipe.

Make sure that the groove diameter stop (consisting of two 7/8" -14 hex nut located on the top back of the

Groover) is not in contact with the top surface of the housing. If contact is noted, release hydraulic pressure by turning the release valve knob counterclockwise allowing the groover head to raise upward. Turn the nut counterclockwise sufficiently to allow clearance between the bottom of nut and top of housing when the top grooving roll is in contact with the pipe.

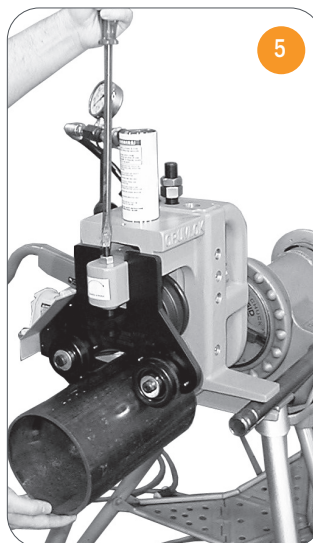

5 The Groover should be leveled for best grooving results. Place level on top of hydraulic ram as shown and adjust the support legs as required to level the Groover and provide a firm fixed base location for both the Groover and power drive.

6 Use one (1) roller pipe stand to support the pipe. Adjust the outboard pipe stand to assure proper contact with the guide rolls. Pipe stand should be 65 - 75% of the pipe length away from Groover. Looking at the front of the Groover, the pipe stand should be positioned to angle the tube approximately 0° to 1/4° downward, away from the front of the Groover and 1/4° to the left side at the Groover. See Figures Below.

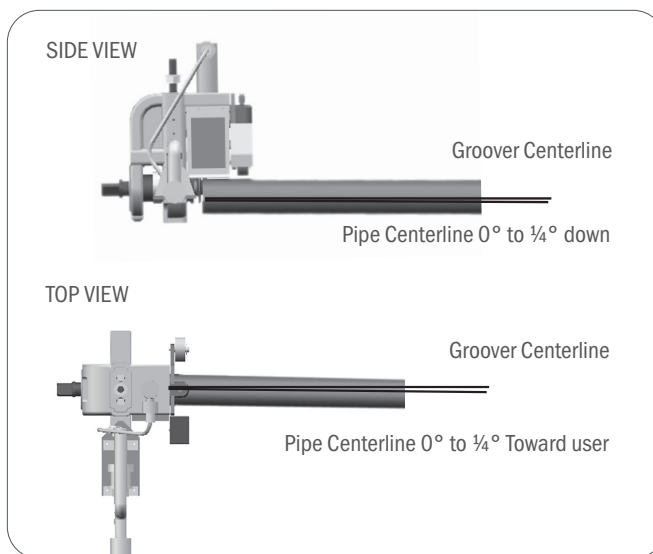

SETTING GROOVE DIAMETER

Set-up and position the pipe as shown on page 7.

A. WITH DEPTH GAUGE

- 1 Maintain approximately 100 psi pump pressure as established on page 7 paragraph 4.



Slide the U-shaped depth gauge, for the pipe size to be grooved under the lowest hex nut (groove diameter stop) at the top back of the Groover. Each gauge is marked with various pipe size ranges. Place the correct pipe size area, for the size of pipe being grooved, under the lower hex nut (groove diameter stop).

Note: For CTS Copper System, use the CTS Depth Gauges.

- 3 Turn the lowest hex nut (groove diameter stop) to snug against the surface of the groove diameter gauge. Turn the jam nut (upper hex nut) to snug with lower hex nut (groove diameter stop). Release the pump pressure by turning the pump relief valve counter-clockwise and remove the groove diameter gauge

A. OPTIONAL METHOD - WITHOUT DEPTH GAUGE

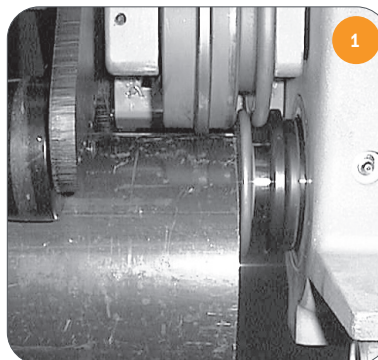

Increase the pump pressure so that the pipe is firmly held between the groove and drive rollers without forming a dent.



Turn the lowest hex nut (groove diameter stop) to snug against the top surface of the Groover.

- 3 Back the hex nut (groove diameter stop) off the number of turns specified in the accompanying chart. Turn the jam nut (upper hex nut) to snug with lower hex nut (groove diameter stop). Release the pump pressure by turning the pump release valve counterclockwise.

HEX NUT TURNS

	Pipe Diameter										
	2	2½	3	4	5	6	8	10	12		
Portion of Turn	½	½	½	½	¾	¾	¾	¾	¾	¾	¾

GROOVING IPS STEEL PIPE



Recheck for correct pipe set-up and position on the bottom roll and adjust as required. Close the release valve on the hydraulic hand pump and increase pump pressure so that the groove roll is in firm contact (Sch. 10 approx. 400 psi / Sch. 40 approx. 800 psi) with the pipe OD.

Check to see that the Ridgid® 300 drive directional switch is set to **reverse** (clockwise rotation of the pipe looking at the front of the Groover.)

- 2 start the drive motor by depressing the foot switch to rotate the pipe. Assure that the pipe is tracking firmly against the back of the bottom roll.



With the pipe rotating, increase grooving force by slowly pumping the hydraulic pump handle to raise pump pressure. Do not pump too fast. Continue to raise the pressure until a groove starts being formed. Use the following table as a guide for grooving pressures.

STEEL PIPE RECOMMENDED SET-UP PRESSURE		
Pipe Size	Wall	Set-up Pressure
<i>Inches</i>	<i>Schedule</i>	<i>PSIG</i>
2" - 6"	10	1,200-1,600
8"	10	4,600-5,000
10"	.188"	4,600-5,000
12"	.219"	4,600-5,000
2"	40	2,800-3,200
2 1/2" - 4"	40, 40S	4,200-4,600
5" - 8"	40	4,600-5,000
5" - 6"	40S	4,600-5,000



Maintain grooving force until the hex nut (groove diameter stop) comes into full, firm contact with the top of the groover base head. Allow the pipe to rotate 1 to 2 revolutions assuring completion of the groove. Release the foot switch to allow the pipe to stop rotation.



Open the hydraulic hand pump release valve by turning counterclockwise. Remove the pipe from the Groover.

Using a pi tape, check the groove diameter produced and compare it to specifications presented on page 10. If required, adjust groove diameter stop to

ensure grooves produced are within specified limits.

Note: Adjustment of the Hex Nut (groove diameter stop) will produce the below listed groove diameter changes.

HEX NUT ADJUSTMENT	GROOVE DIAMETER CHANGE
<i>Turns</i>	<i>Inches</i>
1/6	.024"
1/3	.048"
1/2	.071"
2/3	.095"
5/6	.119"
1	.142"

Clockwise rotation – Increase groove diameter

Counterclockwise rotation – Decrease groove diameter

- 6 After adjustment of the groove diameter stop, if the groove diameter is large (i.e. shallow groove depth), place the pipe end back into the Groover and complete the same groove to the new diameter stop setting. If the groove diameter is small (i.e. deep groove depth), put an unfinished end into the Groover and roll a new groove. Recheck the groove diameter for conformance to grooving specifications.

GROOVING CTS COPPER SYSTEM



1

Recheck for correct tube set-up and position on the bottom roll and adjust as required. Close the release valve on the hydraulic hand pump and increase pump pressure so that the groove roll is in firm contact (approx.

200 psi) with the tube OD. Check to see that the Ridgid® 300 drive directional switch is set to **reverse** (clockwise rotation of the tube looking at the front of the Groover.)

2

Start the drive motor by depressing the foot switch to rotate the tube. Assure that the tube is tracking firmly against the back of the bottom roll.

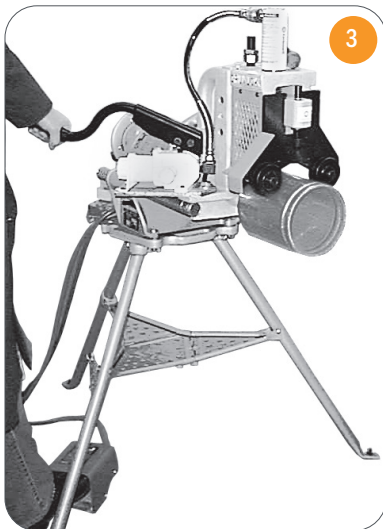

3

With the tube rotating, increase grooving force by **slowly** pumping the hydraulic pump handle to raise pump pressure. Do not pump too fast. Continue to raise the pressure until a groove starts being formed. Use the following table as a guide for grooving pressures.



4

Maintain grooving force until the hex nut (groove diameter stop) comes into full, firm contact with the top of the groover base head. Allow the tube to rotate 1 to 2 revolutions assuring completion of the groove. Release the foot switch to allow the tube to stop rotation.



5

Open the hydraulic hand pump release valve by turning counterclockwise. Remove the tube from the Groover.

Using a pi tape, check the groove diameter produced and compare it to specifications presented on page 17.

If required, adjust groove diameter stop to ensure grooves produced are within specified limits.

Note: Adjustment of the Hex Nut (groove diameter stop) will produce the below listed groove diameter changes.

HEX NUT ADJUSTMENT		GROOVE DIAMETER CHANGE
Turns		Inches
1/6		.024"
1/3		.048"
1/2		.071"
2/3		.095"
5/6		.119"
1		.142"

Clockwise rotation - Increase groove diameter

Counterclockwise rotation - Decrease groove diameter

6

After adjustment of the groove diameter stop, if the groove diameter is large (i.e. shallow groove depth), place the tube end back into the Groover and complete the same groove to the new diameter stop setting. If the groove diameter is small (i.e. deep groove depth), put an unfinished end into the Groover and roll a new groove. Recheck the groove diameter for conformance to grooving specifications.

CTS COPPER SYSTEM RECOMMENDED GROOVING PRESSURE

Tube Size	COPPER TUBING TYPE			
	K Pressure	L Pressure	M Pressure	DWV Pressure
In.	PSI	PSI	PSI	PSI
2"	900	800	600	-
2½"	1,100	900	800	-
3"	1,100	900	800	400
4"	1,400	1,200	900	500
5"	1,800	1,400	1,100	700
6"	1,500	1,100	800	900
8"	2,000	2,400	1,500	1,100

GROOVING ROLL CHANGE - ROLL REMOVAL

NOTE Note: First remove the guide roll mounting plate, then the top groove roll and last the bottom drive roll.

A. GUIDE ROLL MOUNTING PLATE



1 Place one hand under the guide roll mounting plate. Using a $\frac{3}{4}$ " wrench, remove the hex nut from the top of the adjustment shaft protruding from the top of the groover head.



2 Remove the guide roll mounting plate by lowering the shaft out of the mounting block at the front of groover head.

B. TOP (GROOVED) ROLL



1 Loosen (approximately 5 turns) the shaft locator set screw in the groover head to disengage the set screw from the slot in top roll shaft ($\frac{5}{32}$ " allen wrench)

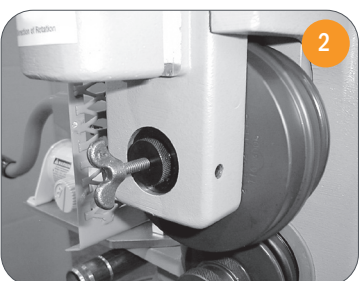

2 Screw the $\frac{1}{4}$ " -20 thumb screw (stored on the pump side of the main housing) into the drilled and tapped hole in the front of the top shaft.

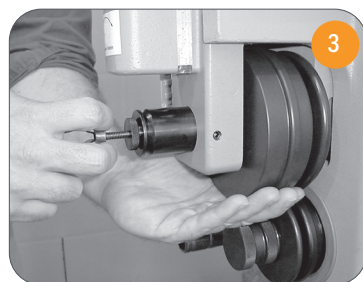

3 Cradle one hand under the top roll and pull the top roll shaft from the front.
CAUTION: The top roll is heavy. Brace your hand to receive the weight of the top roll. As the shaft disengages from the top roll, the top roll will fall into your hand.

Lower the top roll from between the front and back plates of the grooving head.

4 Remove thumb screw from top shaft and return to storage location.

C. BOTTOM (DRIVE) ROLL

Note: There is no need to unchuck the Groover from the Ridgid® 300 drive.



1 Loosen the set screw on the sliding sleeve located between the front and back bearings on the bottom shaft. ($\frac{5}{32}$ " allen wrench) If you cannot see the set screw, turn the power back on to the Ridgid® 300 drive and use the foot switch to rotate the sleeve until the screw

can be seen. Then turn off the power to the Ridgid® 300 drive and unplug it. **DO NOT PROCEED FURTHER UNTIL THE MACHINE HAS BEEN UNPLUGGED.**



2 Slide the sleeve toward the back bearing, revealing the dowel pin hole in the shaft. Push the dowel pin completely out of the shaft. ($\frac{3}{8}$ " pin driver)



3 Pull the bottom roller out from the front of the Groover.

GROOVING ROLL CHANGE - ROLL INSTALLATION

A. GUIDE ROLL MOUNTING PLATE

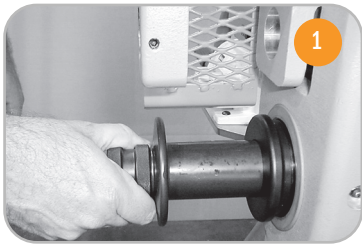

1 Insert the bottom roll shaft through the front of the groover.

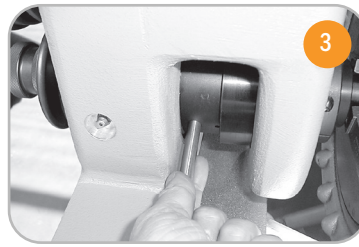

3 Insert the dowel pin until it is flush with the bottom shaft surface.

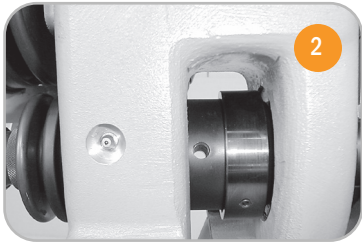

2 Rotate the bottom roll to align the dowel pin hole on the side of the machine.



4 Slide the retaining sleeve over the dowel pin hole and tighten the set screw. ($\frac{5}{32}$ " allen wrench)

B. TOP (GROOVED) ROLL



1 Raise the groove roll between the front and back plates of the groover head. The deep slot in the top roller should be located toward the back of the groover.



2 Insert the top shaft into the front of the machine so that the V-groove is towards the front. Push the shaft backward until the front is approximately even with the front face of the machine.



3 Tighten the locator socket setscrew ($\frac{5}{32}$ " allen wrench). This will align the V-groove with the locator setscrew in the groover head. Care should be taken to avoid contacting the plain diameter of the shaft.

C. BOTTOM (DRIVE) ROLL

Select the correct mounting plate for either steel pipe or for copper tube.



1 Insert the adjustment shaft from the bottom, into the hole in the mounting block at the front of the groover head.

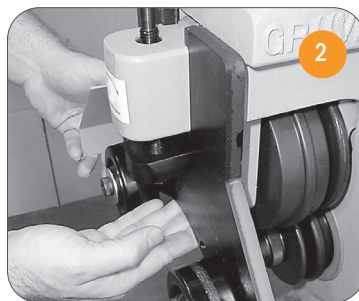

2 Slide the shaft up to expose the threaded portion at the top of mounting block.



3 Using a $\frac{3}{4}$ " wrench, install and snug the hex nut on the top of the adjustment shaft.

GROOVING MAINTENANCE

Routine maintenance of the model 3006/3006C Roll Groover requires periodic application of general purpose lithium grease (NLGI No. 2) to the front bearing and keyways. Under normal usage, the bearing should be lubricated monthly and the keyways should be lightly lubricated on a weekly basis. Frequency of lubrication should be increased in harsh environments.

A. GREASE FITTINGS

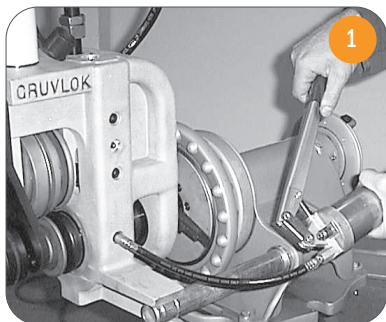

1 Apply grease to front bearing with a grease gun with a 1/4" fitting attachment to the lower grease fitting on the left side of the Groover.

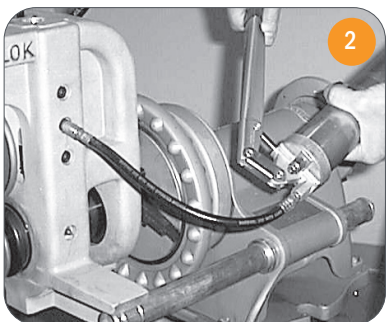

2 Apply grease to left key with a grease gun with a 1/4" fitting attachment to the upper grease fitting on the left side of the Groover.

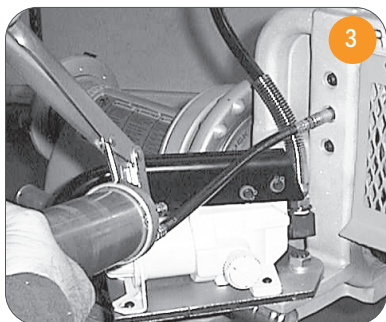

3 Apply grease to right key with a grease gun with a 1/4" fitting attachment to the right side of the Groover.

B. REPLACEMENT PARTS

Please contact your Anvil Representative to purchase replacement parts for the Roll Groover. To ease ordering, an exploded drawing of each machine and a complete replacement parts list is given in the next section. For a list of Anvil Customer Service Centers, please see the last page of this booklet.

C. HYDRAULIC MAINTENANCE

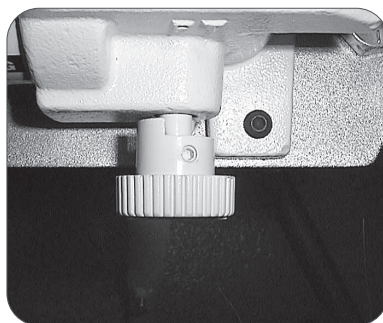

If you are having problems maintaining hydraulic pressure, verify that the release valve knob on the pump is not hitting the pump housing prior to the valve closing completely.

There should be a slight gap between the end of the knob and the pump body. If there is not, loosen the set screw on the knob

and slightly pull it off the valve shaft so that the valve can be closed completely without interference. Then tighten set screw to lock the knob in the proper position. If this does not solve the hydraulic problem, please contact your local Anvil Representative for further instructions.

REPLACEMENT PARTS- 3006/3006C

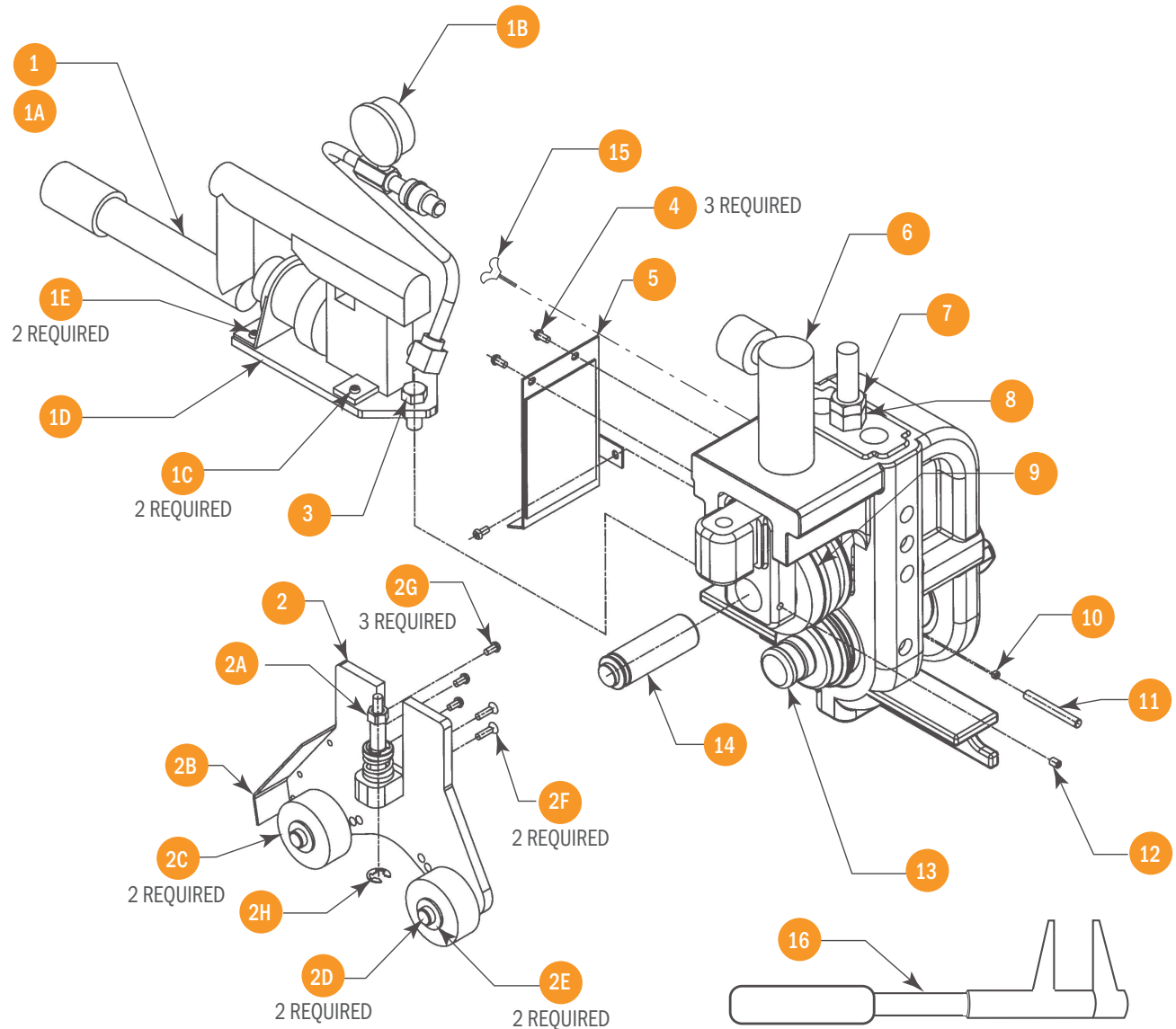

ID	PART NAME	PART NO	ID	PART NAME	PART NO	ID	PART NAME	PART NO
1	Pump Assembly	GL11355	3	Hex Bolt, 5/8-11, L= 1.5"	GL11091	13	Bottom Roller:	
	The Pump Assembly consists of the following:		4	Cap Screw, 1/4-20,L= 12"	GL11230	2"	-6" Steel Bottom Roller	GL11284
	1A Hydraulic Pump	GL11356	5	Safety Mesh	GL11280	8"	-12" Steel Bottom Roller	GL11299
	1B Hydraulic Pressure Gauge	GL11084	6	Hydraulic Ram	GL11095	2"	-8" CTS Copper	
	1C Cap Screw, 1/4-20, L= 5/8	GL11093	7	Jam Nut, 7/8-14	GL11277		Bottom Roller (OPT)	GL13805
	1D Pump Plate	GL11297	8	Hex Nut, 7/8-14	GL11276	14	Top Shaft	GL11281
	1E Cap Screw, 1/4-20, L= 1/2"	GL11230	9	Top Roller:		15	Thumb Screw 1/4 - 20, L=1"	GL11056
2	Steel/CTS Dual Guide Roll Assy.	GL11291		2"-6" Steel Top Roller	GL11285	16	Depth Gauge:	
	The Guard Assembly consists of the following:			8"-12" Steel Top Roller	GL11300	1"	-4" Steel Depth Gauge	GL11344
	2A Hex Nut, 1/2"	GL11198		2"-8" CTS Copper Top Roller (OPT)	GL13803	5"	-12" Steel Depth Gauge	GL11345
	2B Guide Roll Guard	GL11304	10	Cup Point Set Screw, 5/16-18	GL11289	2"	-6" CTS Depth Gauge(OPT)	GL13852
	2C Guide Roll	GL11106	11	Dowel Pin	GL11290	8"	CTS Depth Gauge (OPT)	GL13853
	2D Shoulder Bolt, 1/2"	GL11107	12	Cone Pt. Set Screw, 5/16-18	GL11066		Support Leg Assembly	GL11374
	2E Washer, 1/2"	GL11109						
	2F Flat Head Screw, 1/4-20, L=3/4"	GL11108						
	2G Cap Screw, 1/4-20,L= 1/2"	GL11230						

GROOVE SPECIFICATION - STEEL

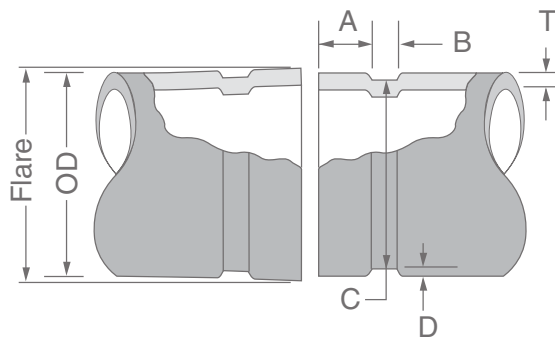

GRUVLOK STANDARD ROLL GROOVE SPECIFICATIONS FOR STEEL & OTHER IPS SIZE PIPE

-1-	-2-			-3-	-4-	-5-		-6-	-7-	-8-
Nominal IPS Pipe Size	Pipe OD			Gasket Seat	Groove Width	Groove Diameter		Groove Depth	Min. Allow. Wall Thickness "T"	Max. Flare Diameter
	Actual	Tolerance		"A"	"B"	"C"		"D"		
	<i>ln_s/DN(mm)</i>	<i>ln_s/mm</i>	<i>+ln_s/mm</i> / <i>-ln_s/mm</i>	<i>ln_s/mm</i>	<i>ln_s/mm</i>	<i>ln_s/mm</i>	<i>Tol. +0.000</i>	<i>(Ref. Only)</i>		
	<i>ln_s/mm</i>	<i>+ln_s/mm</i>	<i>-ln_s/mm</i>	<i>ln_s/mm</i>	<i>ln_s/mm</i>	<i>ln_s/mm</i>	<i>-ln_s/mm</i>	<i>ln_s/mm</i>	<i>ln_s/mm</i>	<i>ln_s/mm</i>
2	2.375	+0.024	-0.024	0.625	0.344	2.250	-0.015	0.063	0.065	2.480
50	60.3	+0.61	-0.61	15.88	8.74	57.15	-0.38	1.60	1.7	63.0
2½	2.875	+0.029	-0.029	0.625	0.344	2.720	-0.018	0.078	0.083	2.980
65	73.0	+0.74	-0.74	15.88	8.74	69.09	-0.46	1.98	2.1	75.7
3	3.500	+0.035	-0.031	0.625	0.344	3.344	-0.018	0.078	0.083	3.600
80	88.9	+0.89	-0.79	15.88	8.74	84.94	-0.46	1.98	2.1	91.4
3½	4.000	+0.040	-0.031	0.625	0.344	3.834	-0.020	0.083	0.083	4.100
90	101.6	+1.02	-0.79	15.88	8.74	97.38	-0.51	2.11	2.1	104.1
4	4.500	+0.045	-0.031	0.625	0.344	4.334	-0.020	0.083	0.083	4.600
100	114.3	+1.14	-0.79	15.88	8.74	110.08	-0.51	2.11	2.1	116.8
5	5.563	+0.056	-0.031	0.625	0.344	5.395	-0.022	0.084	0.109	5.660
125	141.3	+1.42	-0.79	15.88	8.74	137.03	-0.56	2.13	2.8	143.8
6	6.625	+0.063	-0.031	0.625	0.344	6.455	-0.022	0.085	0.109	6.730
150	168.3	+1.60	-0.79	15.88	8.74	163.96	-0.56	2.16	2.8	170.9
8	8.625	+0.063	-0.031	0.750	0.469	8.441	-0.025	0.092	0.109	8.800
200	219.1	+1.60	-0.79	19.05	11.91	214.40	-0.64	2.34	2.8	223.5
10	10.750	+0.063	-0.031	0.750	0.469	10.562	-0.027	0.094	0.134	10.920
250	273.1	+1.60	-0.79	19.05	11.91	268.27	-0.69	2.39	3.4	277.4
12	12.750	+0.063	-0.031	0.750	0.469	12.531	-0.030	0.109	0.156	12.920
300	323.9	+1.60	-0.79	19.05	11.91	318.29	-0.76	2.77	4.0	328.2

OUT OF ROUNDNESS: Difference between maximum O.D. and minimum O.D. measured at 90° must not exceed total O.D. tolerance listed (reference column 2).

FOR IPS PIPE, the maximum allowable tolerance from square cut ends is 0.03" for 2" thru 3½"; 0.045" for 4" thru 6"; and 0.060" for sizes 8" and above measured from a true square line.

BEVELED-END PIPE in conformance with ANSI B16.25 (37½°) is acceptable, however square cut is preferred.

COLUMN 1 - Nominal IPS Pipe size

COLUMN 2 - IPS outside diameter

COLUMN 3 - Gasket seat must be free from scores, seams, chips, rust or scale which may interfere with proper sealing of the gasket. Gasket seat width (Dimension A) is to be measured from the pipe end to the vertical flank in the groove wall.

COLUMN 4 - Groove width (Dimension B) is to be measured between vertical flank of the groove size walls.

COLUMN 5 - The groove must be of uniform depth around the entire pipe circumference. (See column 6).

COLUMN 6 - Groove depth: for reference only. Groove must conform to the groove diameter "C" listed in column 5.

COLUMN 7 - Minimum allowable wall thickness which may be roll grooved.

COLUMN 8 - Maximum allowable pipe end flare diameter. Measured at the most extreme pipe end diameter of the gasket seat area.

GROOVE SPECIFICATION - CTS COPPER SYSTEM

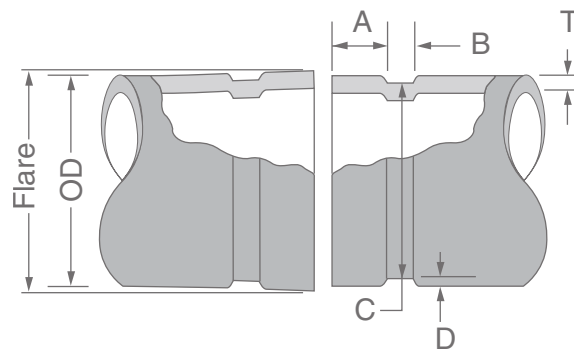

GRUVLOK CTS COPPER SYSTEM - ROLL GROOVE SPECIFICATIONS

-1- Nominal Size	-2- Tubing Outside Diameter			-3- Gasket Seat "A" +/- 0.03 in. +/- 0.76mm	-4- Groove Width "B" +0.03/-0.00 in. +0.76/-0.00mm	-5- Groove Diameter "C"		-6- Nominal Groove Depth "D"	-7- Min. Wall "T"	-8- Max. Flare Diam.
	Actual	Tolerance				Actual	Tolerance +0.000			
		In./mm	+ In./mm							
2	2.125	0.002	0.002	0.610	0.300	2.029	-0.020	0.048	0.058	2.220
	54.0	0.05	0.05	15.5	7.6	51.54	-0.51	1.2	1.6	56.4
2½	2.625	0.002	0.002	0.610	0.300	2.525	-0.020	0.050	0.065	2.720
	66.7	0.05	0.05	15.5	7.6	64.14	-0.51	1.3	1.7	69.1
3	3.125	0.002	0.002	0.610	0.300	3.025	-0.020	0.050	DWV	3.220
	79.4	0.05	0.05	15.5	7.6	76.84	-0.51	1.3		81.8
4	4.125	0.002	0.002	0.610	0.300	4.019	-0.020	0.053	DWV	4.220
	104.8	0.05	0.05	15.5	7.6	102.08	-0.51	1.3		107.2
5	5.125	0.002	0.002	0.610	0.300	4.999	-0.020	0.053	DWV	5.220
	130.2	0.05	0.05	15.5	7.6	126.97	-0.51	1.3		132.6
6	6.125	0.002	0.002	0.610	0.300	5.999	-0.020	0.063	DWV	6.220
	155.6	0.05	0.05	15.5	7.6	152.37	-0.51	1.6		158.0
8	8.125	0.002	0.004	0.610	0.300	7.959	-0.020	0.083	DWV	8.220
	206.4	0.05	0.10	15.5	7.6	202.16	-0.51	2.1		208.8

COLUMN 1 - Nominal tubing size ASTM B88

COLUMN 2 - Outside diameter of copper tubing per ASTM B88. Allowable tolerance from square cut ends is 0.030"/0.76mm for sizes 2"-3"; 0.045"/1.14mm for sizes 4-8"

COLUMN 3 - Gasket seat must be free from scores, roll marks, indentations, grease and dirt which may interfere with gasket sealing.

COLUMN 4 - Groove width is to be free from chips, dirt, etc. which may interfere with proper coupling assembly.

COLUMN 5 - Groove diameter must be of uniform depth for the entire circumference of the tubing. (See column 6).

COLUMN 6 - Groove depth is for reference only; the groove diameter must conform to column 5.

COLUMN 7 - DWV (Drain, Waste and Vent Piping) per ASTM B306.

COLUMN 8 - Maximum flare diameter is the OD at the most extreme tubing diameter.

TROUBLESHOOTING

TROUBLESHOOTING INSTRUCTIONS		
Problem	Possible Cause	Solution
1 Pipe will not stay in grooving rolls.	<p>Incorrect pipe positioning.</p> <p>Improper grooving technique.</p> <p>Power drive running counterclockwise Model 3007.</p>	<p>See "Pipe Set-up & Positioning"</p> <p>See "Grooving Pipe"</p> <p>Ridgid 300 check setting in reverse</p> <p>Clockwise rotation of pipe</p>
2 Pipe stops rotating during grooving.	<p>Rust or dirt has built up on lower roll.</p> <p>Worn grooving rolls.</p> <p>Ridgid 300 chuck jaws not engaged properly.</p> <p>Steel Pipe – Groove Diameter Stop improperly adjusted.</p> <p>Copper Tube – Groove Diameter Stop making contact with top surface of Groover.</p>	<p>Remove accumulation from lower roll with stiff wire brush.</p> <p>Inspect lower rolls for worn knurls, replace if worn.</p> <p>See "Groover Set-up"</p> <p>Adjust Groove Diameter Stop to correct IPS.</p> <p>Verify Groove Diameter Stop Nuts are fully backed off.</p>
3 Pipe flare excessive	<p>Pipe stand adjusted too high.</p> <p>Tool is tilted forward.</p> <p>Incorrect pipe stand offset positioning. Pipe is over "tracking".</p> <p>Warped bottom roll shaft.</p>	<p>See "Pipe Set-up & Positioning"</p> <p>See "Groover Set-up"</p> <p>See "Pipe Set-up & Positioning"</p> <p>Replace damaged bottom roll shaft. The hinged collar may be missing. Replace damaged parts.</p>
4 While grooving loud squeaks echo through the pipe or tube.	<p>Pipe or Tube not square cut.</p> <p>Incorrect pipe roller offset positioning.</p> <p>Pipe is over "tracking".</p>	<p>Cut pipe or tube ends squarely.</p> <p>Move pipe stand for proper offset.</p> <p>See "Pipe Set-up & Positioning"</p>
5 During grooving loud thumps or bangs occur about once every revolution of the pipe.	<p>Pipe has a pronounced weld seam.</p>	<p>Grind welds flush with pipe surface inside & out 2" back from pipe end.</p>
6 Tool won't groove pipe.	<p>Hand pump is low on oil.</p> <p>Air in hydraulic system.</p> <p>Pipe wall thickness exceeds tool's capability.</p>	<p>See "Groover Maintenance"</p> <p>See "Groover Maintenance"</p> <p>See "Groover Description"</p>

About ASC Engineered Solutions

ASC Engineered Solutions is defined by quality—in its products, services and support. With more than 1,400 employees, the company’s portfolio of precision-engineered piping support, valves and connections provides products to more than 4,000 customers across industries, such as mechanical, industrial, fire protection, oil and gas, and commercial and residential construction. Its portfolio of leading brands includes ABZ Valve®, AFCON®, Anvil®, Anvil EPS, Anvil Services, Basic-PSA, Beck®, Catawissa, Cooplet®, FlexHead®, FPPI®, Gruvlok®, J.B. Smith, Merit®, North Alabama Pipe, Quadrant®, SCI®, Sharpe®, SlideLOK®, SPF® and SprinkFLEX®. With headquarters in Commerce, CA, and Exeter, NH, ASC also has ISO 9001:2015 certified production facilities in PA, TN, IL, TX, AL, LA, KS, and RI.



asc-es.com

Building connections that last™

