

# OPERATOR'S MANUAL

# LM2250E-X-B

INCLUDING: SPECIFICATIONS, SERVICE KITS, GENERAL INFORMATION, PARTS, TROUBLESHOOTING  
INCLUDE MANUAL: S-632 GENERAL INFORMATION (PN 97999-624)

RELEASED: 6-1-00  
REVISED: 10-13-11  
(REV. M)

2" AIR MOTOR  
50:1 RATIO  
0 - 7500 P.S.I. RANGE



## LM2250E-( )-B CHOP-CHECK GREASE PUMP



**READ THIS MANUAL CAREFULLY BEFORE INSTALLING,  
OPERATING OR SERVICING THIS EQUIPMENT.**

It is the responsibility of the employer to place this information in the hands of the operator. Keep for future reference.

### SERVICE KITS

- Use only genuine ARO® replacement parts to assure compatible pressure rating and longest service life.
- **637332 Pump Rebuild Kit.** Includes the necessary soft parts for normal service of the entire pump.

### SPECIFICATIONS

Model Series	LM2250E-X-B
Type	Air Operated, Chop-Check Grease Pump
Ratio	50:1
Air Motor Diameter	2" (5.08 cm)
Stroke	3" (7.62 cm)
Air Inlet (female)	
LM2250E-X1-B	1/4 - 18 N.P.T.F. - 1
LM2250E-X2-B	Rp 1/4 (1/4 - 19 BSP Parallel)
Material Outlet (female)	
LM2250E-X1-B	3/8 - 18 N.P.T.F. - 1
LM2250E-X2-B	Rc 3/8 (3/8 - 19 BSP Taper)
Pump Construction	Carbon Steel
Dimensional Data	see chart
Weight	see chart

### PERFORMANCE

Air Inlet Pressure Range	0 - 150 p.s.i. (0 - 10.3 bar)
Fluid Pressure Range	0 - 7500 p.s.i. (0 - 517.2 bar)
Cycles / Minute Rec'd @ Working Flow	80
Displacement In <sup>3</sup> Per Cycle	0.300
Volume / Cycle	0.17 oz. (4.91 ml)
Maximum Delivery / Minute	9 lbs (4.1 kg)
Noise Level @ 100 p.s.i.	85 db(A)*
Accessories Available	61113 Wall Mount Bracket 66073-1 Air Line Connection Kit

\* The pump sound pressure level has been updated to an Equivalent Continuous Sound Level (L<sub>Aeq</sub>) to meet the intent of ANSI S1. 13-1971, CAGI-PNEUROP S5.1 using four microphone locations.

### GENERAL DESCRIPTION

Model LM2250E-X-B series chop-check grease pump is intended to be used primarily for grease delivery systems. It uses carbon steel and other materials which make it compatible with most petroleum based lubrication products.

NOTE: If this pump was purchased separately (not part of a system), consult your sales representative for compatible dispensing accessories which will best match the application. All accessories must be able to withstand the maximum pressure developed by the pump.

#### INGERSOLL RAND COMPANY LTD

209 NORTH MAIN STREET - BRYAN, OHIO 43506

☎ (800) 495-0276 • FAX(800) 892-6276

© 2011

CCN 99879389

www.ingersollrandproducts.com

### PUMP DATA

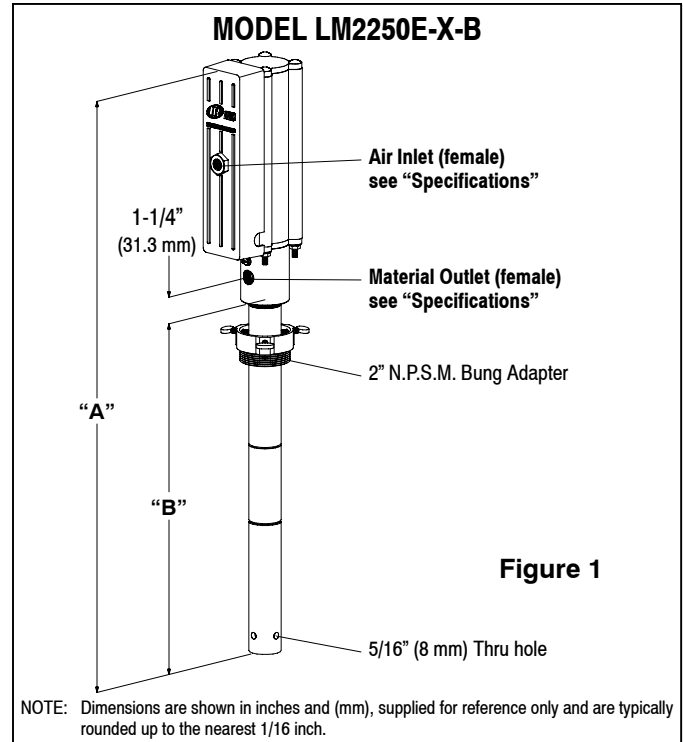

MODEL	"A" (mm)	"B" (mm)	WEIGHT (kg)
LM2250E-21-B	27-3/4" (704)	16-9/16" (421)	15 (6.8)
LM2250E-22-B	27-3/4" (704)	16-9/16" (421)	15 (6.8)
LM2250E-31-B	38-7/16" (976)	27-1/4" (692)	18.3 (8.3)
LM2250E-32-B	40-1/2" (1028)	29-5/16" (744)	19 (8.6)
LM2250E-41-B	48" (1219)	36-13/16" (935)	21.2 (9.6)
LM2250E-42-B	49" (1244)	37-13/16" (960)	21.5 (9.8)
LM2250E-61-B	30-1/2" (774)	19-5/16" (490)	15.9 (7.2)
LM2250E-62-B	30-1/2" (774)	19-5/16" (490)	15.9 (7.2)
LM2250E-M2-B	36-15/16" (937)	25-3/4" (653)	17.8 (8.1)

### IMPORTANT

This is one of two documents which support the pump. Replace-ment copies of these forms are available upon request.

- LM2250E-X-B Model Operator's Manual (pn 97999-914)
- S-632 General Information Lubrication Piston Pumps (pn 97999-624)

**⚠ WARNING READ THE GENERAL INFORMATION MANUAL INCLUDED FOR ADDITIONAL OPERATING AND SAFETY PRE-CAUTIONS AND OTHER IMPORTANT INFORMATION.**

# ARO

**IR** Ingersoll Rand  
Industrial Technologies

## PARTS LIST / LM2250E-XX-B

Item	Description (size)	Qty	Part No.	[Mtl]
1	Carriage Bolt (1/4" - 20 x 9" long)	(4)	94333	[C]
2	Upper Cap	(1)	94307	[Z]
✓ 3	Gasket	(2)	94311	[B]
4	Sleeve	(2)	94316	[Br]
✓ 5	"O" Ring (1/16" x 11/16" o.d.)	(4)	Y325-15	[B]
✓ 6	"O" Ring (1/8" x 3/4" o.d.)	(4)	Y325-206	[B]
7	Spool	(2)	94310	[D]
✓ 8	"U" Cup (1/8" x 3/4" o.d.)	(2)	Y240-7	[B]
✓ 9	"O" Ring (0.106" x 0.587" o.d.)	(2)	15066-PM	[B]
10	Cylinder	(1)	94249	[A]
11	Adapter - models LM2250E-X1-B	(1)	94447	[C]
	- models LM2250E-X2-B	(1)	94447-1	[C]
✓ 12	"O" Ring (1/16" x 3/4" o.d.)	(1)	Y325-16	[B]
✓ 13	"O" Ring (1/16" x 7/16" o.d.)	(1)	Y325-11	[B]
14	Muffler Housing	(1)	94443	[A]
15	Foam Liner	(2)	94402	
16	Retaining Ring	(1)	94406	[C]
17	Washer	(1)	94515	[C]
✓ 18	"U" Cup (3/16" x 2" o.d.)	(2)	Y240-23	[B]
19	Piston	(1)	94780	[D]
20	Piston Adapter	(1)	94388	[C]
✓ 21	"O" Ring (3/32" x 1" o.d.)	(1)	Y325-117	[B]
22	Dowel Pin (1/4" o.d. x 7/8" long)	(1)	Y148-37	[C]
✓ 23	"O" Ring (3/32" x 13/16" o.d.)	(1)	Y325-114	[B]
✓ 24	Rod Seal	(1)	95139	[U]
25	Washer	(1)	94785	[C]
26	Spring	(1)	94705	[C]
27	Base - models LM2250E-X1-B	(1)	67241	[C/Z]
	- models LM2250E-X2-B	(1)	67241-1	[C/Z]
28	Nut (1/4" - 20)	(4)	93828	[SS]
29	Ground Screw (#10 - 32 x 1/4")	(1)	93005	[C]
✓ 30	Gasket	(1)	70834	[Co]
31	Extension Tube			
	models LM2250E-2X-B (7.531")	(1)	94401-2	[C]
	models LM2250E-31-B (18.219")	(1)	94401-3	[C]
	models LM2250E-32-B (20.281")	(1)	94401-7	[C]
	models LM2250E-41-B (27.781")	(1)	94401-4	[C]
	models LM2250E-42-B (28.781")	(1)	94401-8	[C]

Item	Description (size)	Qty	Part No.	[Mtl]
	models LM2250E-6X-B (10.281")	(1)	94401-6	[C]
	models LM2250E-M2-B (16.698")	(1)	94401-9	[C]
✓ 32	Gasket	(1)	70837	[Co]
33	Piston Rod	(1)	95137	[C]
34	Pin	(1)	94786	[C]
✓ 35	Cotter Pin (1/16" x 1/2" long)	(1)	Y15-21	[C]
36	Connector			
	models LM2250E-2X-B (3.457")	(1)	94340-2	[C]
	models LM2250E-31-B (14.145")	(1)	94340-3	[C]
	models LM2250E-32-B (16.207")	(1)	94340-7	[C]
	models LM2250E-41-B (23.707")	(1)	94340-4	[C]
	models LM2250E-42-B (24.707")	(1)	94340-8	[C]
	models LM2250E-6X-B (6.207")	(1)	94340-6	[C]
	models LM2250E-M2-B (12.624")	(1)	94340-9	[C]
	Piston & Tube Ass'y (includes 37 - 40, 49)	(1)	67262	
37	Lower Suction Tube	(1)		[C]
38	Plunger	(1)		[C]
39	Ball Stop	(1)	83276	[C]
40	Ball (9/32" dia.)	(1)	Y16-209	[C]
✓ 41	Guide Washer	(1)	95131	[Co]
42	Spacer	(1)	72392-1	[C]
✓ 43	Retaining Ring (0.877" o.d.)	(1)	76243-1	[C]
✓ 44	"U" Cup (1/8" x 13/16" o.d.)	(1)	Y186-54	[B]
✓ 45	Guide	(1)	95132	[T]
46	Foot Valve Body	(1)	95133	[SH]
	Foot Valve Assembly (includes 43 - 46)	(1)	67242	
✓ 47	Gasket	(1)	F21-65	[Co]
48	Valve Seat	(1)	6797	[C]
49	Primer Rod	(1)	95134	[C]
50	Primer	(1)	94400	[C]
✓ 51	Retainer Ring	(1)	94397	[C]
52	Primer Tube	(1)	94399	[C]
53	Bung Assembly (includes 54)	(1)	67145-2	[ZA]
54	Thumb Screw (1/4" - 20 x 1")	(3)	Y66-59-C	[C]
✓	Gadus S2 U1000 Grease Packet	(1)	94833	
✓	Parts in Repair Kit		637332	

## OPERATING AND SAFETY PRECAUTIONS

**⚠ WARNING** EXCESSIVE INLET PRESSURE. Can cause explosion resulting in severe injury or death. Do not exceed maximum operating pressure of 7500 p.s.i. (517 bar) at 150 p.s.i. (10.3 bar) inlet air pressure. Do not run pump without using a regulator to limit air supply pressure to the pump.

**⚠ WARNING** EXCESSIVE MATERIAL PRESSURE. Can cause equipment failure resulting in severe injury or property damage. Do not exceed the maximum material pressure of any component in the system.

Replacement warning label is available upon request, PN \ 94520.

$$\text{PUMP RATIO} \times \text{INLET PRESSURE TO PUMP MOTOR} = \text{MAXIMUM PUMP FLUID PRESSURE}$$

Pump ratio is an expression of the relationship between the pump motor area and the lower pump end area. EXAMPLE: When 150 p.s.i. (10.3 bar) inlet pressure is supplied to the motor of a 50:1 ratio pump it will develop a maximum of 7500 p.s.i. (517 bar) fluid pressure (at no flow) - as the fluid control is opened, the flow rate will increase as the motor cycle rate increases to keep up with the demand.

NOTICE: Thermal expansion can occur when the fluid in the material lines is exposed to elevated temperatures. Example: Material lines located in a non-insulated roof area can warm due to sunlight. Install a pressure relief valve in the pumping system.

# PARTS LIST / LM2250E-XX-B

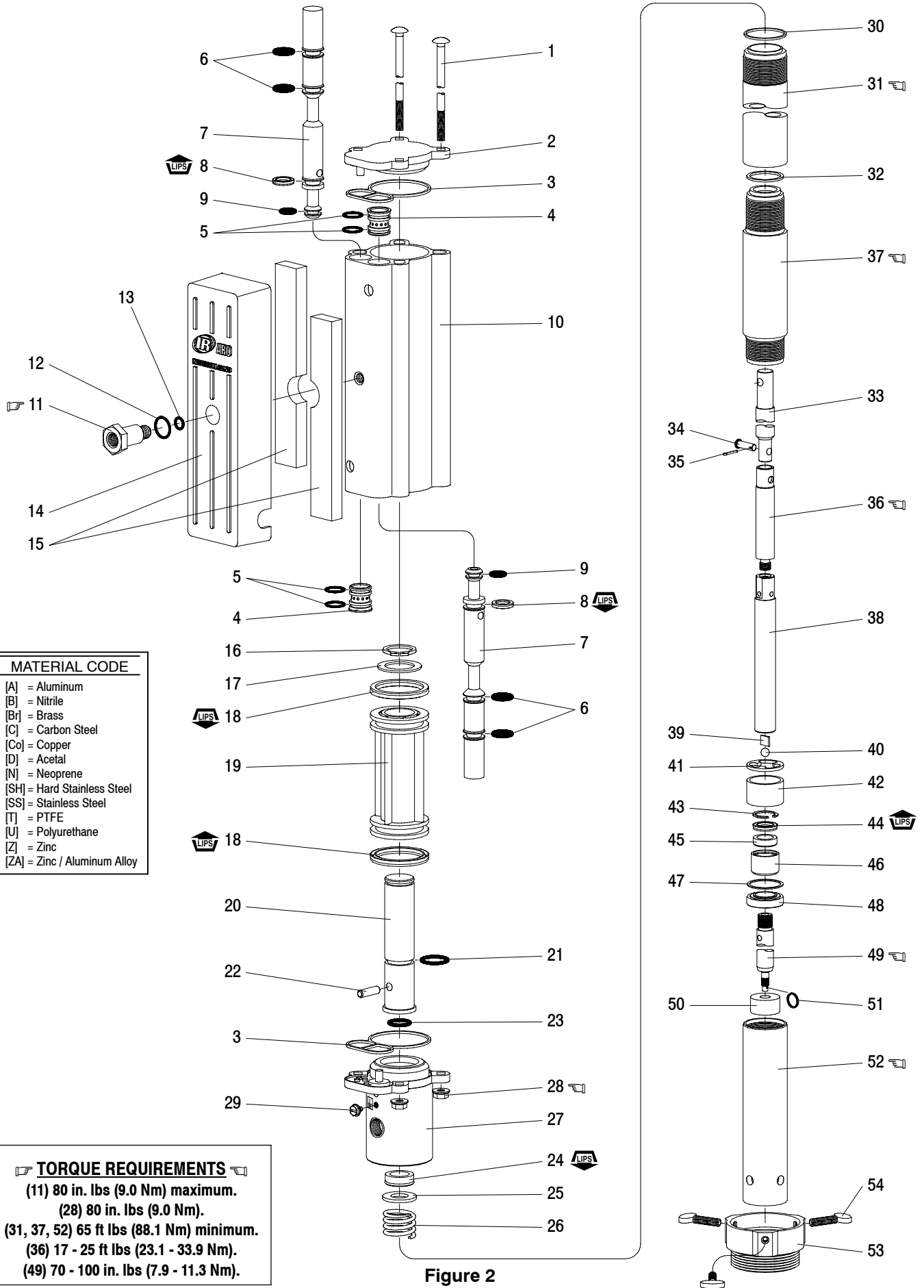

MATERIAL CODE	
[A]	= Aluminum
[B]	= Nitrile
[Br]	= Brass
[C]	= Carbon Steel
[Co]	= Copper
[D]	= Acetal
[N]	= Neoprene
[SH]	= Hard Stainless Steel
[SS]	= Stainless Steel
[T]	= PTFE
[U]	= Polyurethane
[Z]	= Zinc
[ZA]	= Zinc / Aluminum Alloy

**TORQUE REQUIREMENTS**

(11) 80 in. lbs (9.0 Nm) maximum.  
 (28) 80 in. lbs (9.0 Nm).  
 (31, 37, 52) 65 ft lbs (88.1 Nm) minimum.  
 (36) 17 - 25 ft lbs (23.1 - 33.9 Nm).  
 (49) 70 - 100 in. lbs (7.9 - 11.3 Nm).

Figure 2

---

## PUMP DISASSEMBLY

---

**NOTE: All threads are right hand. Refer to figure 2 (page 3). Disconnect air supply and relieve all system pressure prior to servicing.** Carefully remove the parts, inspect for damage, nicks or excessive wear and determine if any parts will need replacement.

1. Using a 7/8" wrench, unthread and remove (11) adapter, containing (12 and 13) "O" rings, releasing (14) muffler housing.
2. Using a 7/16" wrench, remove (28) nuts.
3. Remove four (1) bolts, (2) upper cap and (3) gasket.
4. Remove (10) cylinder, containing (4) sleeves and (7) spools.
5. Using (1) bolt, push (7) spools and (4) sleeves out "sleeve" end of (10) cylinder.
6. Remove (16) retaining ring, (17) washer and (19) piston.
7. Remove (22) dowel pin, releasing (20) piston adapter.
8. Remove (3) gasket.
9. Clamp (31) extension tube horizontally in a vise. Unthread and remove (27) base, (30) gasket, (26) spring and (25) washer. NOTE: Remove (24) rod seal only if replacement is necessary.
10. Pull up on (33) piston rod to reveal (35) cotter pin.
11. Remove (35) cotter pin and (34) connecting pin, releasing (33) piston rod.
12. Using (33) piston rod, push down on (36) connector until it bottoms.
13. Remove (51) retainer ring.
14. Push (50) primer up into (52) primer tube.
15. Lightly wedge a flat blade screwdriver between (50) primer and (52) primer tube, so (50) primer unthreads with (52) primer tube.
16. Insert a 5/16" diameter rod thru the cross holes in (52) primer tube and use the rod to unthread and remove (52) primer tube.
17. Remove (42) spacer, (47) gasket and (48) valve seat from (52) primer tube.
18. Remove (43 - 46) foot valve assembly from (49) primer rod.
19. Remove (43) retaining ring, releasing (44) "U" cup. NOTE: Do not remove (45) guide unless replacement is necessary.
20. Remove (41) guide washer.
21. Clamp (37) lower suction tube horizontally in a vise. Unthread and remove (31) extension tube and (32) gasket.
22. Using a 7/32" diameter rod in the cross hole in (36) connector and a 9/16" wrench on the flats of (38) plunger, unthread and remove (36) connector from (38) plunger. NOTE: Do not damage the o.d. of (38) plunger in any way.
23. Using a 5/32" diameter rod in the cross hole of (49) primer rod and a 9/16" wrench on flats of (38) plunger, unthread and remove (49) primer rod, releasing (40) ball and (39) ball stop.

---

## PUMP REASSEMBLY

---

**NOTE: Thoroughly clean and lubricate all seals and bores with Shell Gadus S2 U1000 upon assembly. Replace all soft parts with new ones included in the repair kit.** Note: Refer to the illustration (figure 2, page 3) for "U" cup lip seal direction.

1. Assemble (39) ball stop and (40) ball into (38) plunger, securing with (49) primer rod. NOTE: Torque (49) primer rod to 70 - 100 in. lbs (7.9 - 11.3 Nm).
2. Thread (36) connector to (38) plunger, using a 7/32" diameter rod thru the cross hole to tighten. NOTE: Tighten (36) connector to 17 - 25 ft lbs (23.1 - 33.9 Nm).

3. Assemble (45) guide and (44) "U" cup into (46) valve body, securing with (43) retaining ring. NOTE: Assemble chamfered corner of (45) guide into (46) valve body first.
4. Assemble (41) guide washer and (43 - 46) foot valve assembly onto (49) primer rod.
5. Assemble (42) spacer, (47) gasket and (48) valve seat onto (49) primer rod.
6. Thread (50) primer onto (49) primer rod, securing with (51) retainer ring.
7. Thread (52) primer tube to (37) lower suction tube and tighten. NOTE: Torque (52) primer tube to 65 - 75 ft lbs (88.1 - 101.7 Nm).
8. Assemble (33) piston rod to (36) connector, securing with (34) connecting pin and (35) cotter pin.
9. Assemble (32) gasket and (31) extension tube to (37) lower suction tube and tighten. NOTE: Torque (31) extension tube to 65 - 75 ft lbs (88.1 - 101.7 Nm).
10. Assemble (23) "O" ring, (24) rod seal, (25) washer, (26) spring and (30) gasket into (27) base and assemble (27) base to (31) extension tube. Clamp (27) base horizontally in a vise and tighten (31) extension tube. NOTE: Torque (31) extension tube to 65 - 75 ft lbs (88.1 - 101.7 Nm).
11. Push up on (50) primer, exposing (33) piston rod.
12. Assemble (3) gasket to (27) base.
13. Assemble (21) "O" ring to (20) piston adapter and assemble (20) piston adapter to (33) piston rod, securing with (22) dowel pin.
14. Replace (18) "U" cups on (19) piston and assemble (19) piston onto (20) piston adapter, securing with (17) washer and (16) retaining ring.
15. Replace (5) "O" rings on (4) sleeves and assemble (4) sleeves into (10) cylinder. NOTE: Assemble each sleeve into the end of the cylinder nearest the exhaust hole.
16. Replace (6 and 9) "O" rings and (8) "U" cups on (7) spools and assemble (7) spools into (10) cylinder from the opposite end as the (4) sleeve went in.
17. Assemble (10) cylinder onto the pump, being careful when sliding over the lips of (18) "U" cups. NOTE: Be sure (3) gasket is seated properly.
18. Replace (3) gasket on (2) upper cap and assemble (2) upper cap to (10) cylinder.
19. Assemble (1) bolts to pump, securing with (28) nuts. NOTE: Torque (28) nuts to 80 - 90 in. lbs (9.0 - 10.2 Nm).
20. Replace (12 and 13) "O" rings on (11) adapter.
21. Assemble (15) foam liners to (14) muffler housing.
22. Assemble (14) muffler housing to (10) cylinder, securing with (11) adapter. NOTE: Torque (11) adapter to 70 - 80 in. lbs (7.9 - 9.0 Nm).

---

## TROUBLE SHOOTING

---

**If the pump will not cycle or will not deliver material.**

- Be certain to check for non-pump problems including kinked, restrictive or plugged inlet / outlet hose or dispensing device. Depressurize the pump system and clean out any obstructions in the inlet / outlet material lines.
- Check all seals, including track gaskets.
- Check direction of "U" cup lips.