

1750 RPM Straight Centrifugal Pump

Model 4301-95



- **Cast Iron Construction**
- **Stainless Steel Precision Cast Dynamically Balanced Impeller**
- **Viton® Silicon Carbide/Carbon Mechanical Seal**
- **6" x 4" 125 Lb. 8-Bolt Flanged Suction Port & 4-Bolt Flanged Discharge Port**
- **Pull-From-Rear Design Permits Easy Servicing Without Disturbing Piping**
- **1/4" NPT Gauge Taps on Suction & Discharge Ports For System Monitoring**
- **Bronze Shaft Sleeve to Protect Motor Shaft**
- **Maximum Casing Pressure 175 PSI**
- **Maximum Temperature 200° F**
- **Includes Seal Flush/Air Relief Valve**
- **Front Drain Plugs**
- **TEFC JM NEMA Frame IE2/EPAC Energy Efficient Motors**

The AMT Cast Iron 1750 RPM Solids Handling End Suction Centrifugal pump delivers performance that minimizes operation and energy costs. Built to last, each pump features a precision cast stainless steel impeller that is dynamically balanced to minimize vibration and maximize motor bearing life. Pull-from-rear design simplifies maintenance without disturbing piping connection. Gauge taps at the suction and discharge ports allow for system monitoring. Maximum 1/4" diameter solids handling and optional seal flush/air relief valve is available for vertical installations. **Pumps require a flooded suction and positive suction pressure.**

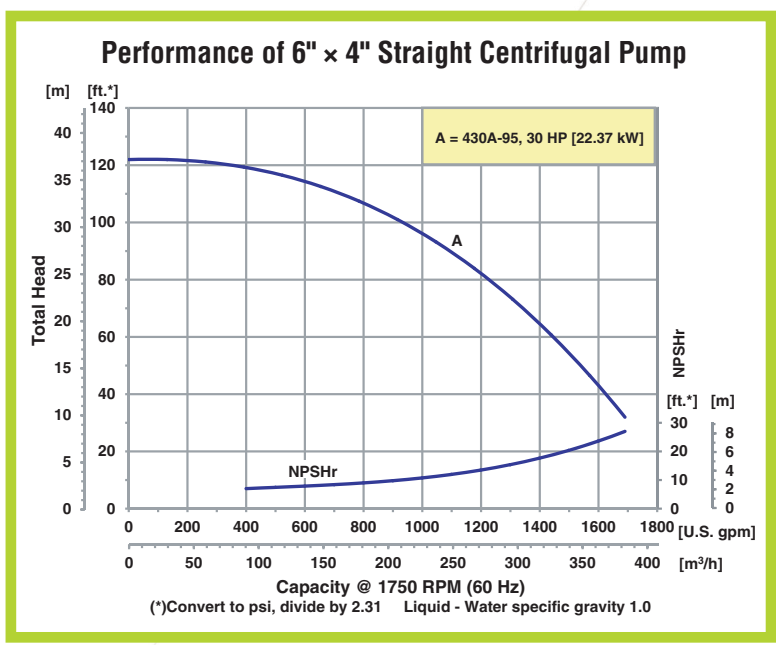

John M. Ellsworth Co., Inc.

P.O. Box 240072
8700 West Bradley Road
Milwaukee, WI 53224

800-333-3331 PHONE

info@jmesales.com E-MAIL
www.JMEsales.com WEB

Pump Dimensional & Specification Data

Model	Curve	HP	PH	Frame	ENC	Voltage @ 60 Hz +	Full Load Amps	SUC*	DIS*	A**	B	C	D	E	F	G	J	L**	W**	H	Ship Wt. (Lbs.)
4301-95	A	30	3	286JM	TEFC	208-230/460	80/36	6 ♦	4 ♦	10.5 [26.8]	7.0 [17.8]	15.1 [38.6]	9.2 [23.5]	5.0 [12.7]	11.0 [27.9]	7.9 [20.2]	11.0 [27.9]	31.2 [79.1]	24.0 [60.9]	18.2 [46.2]	740

(*) Standard NPT (Female) pipe thread.

(**) This dimension may vary due to motor manufacturer's specifications.

(+) 3-Phase motors can also operate on 50 Hz. (this will change full load amps, service factor and RPM)

(♦) Standard 125# Flange

NOTE: Dimensions are in inches (centimeters) and have a tolerance of $\pm 1/4"$.

NOTE: Electric supply for **ALL** motors must be within $\pm 10\%$ of nameplate voltage rating (e.g 230V $\pm 10\%$ =207 to 253)

Maximum Solids Handling Capacity: 1/4" Diameter

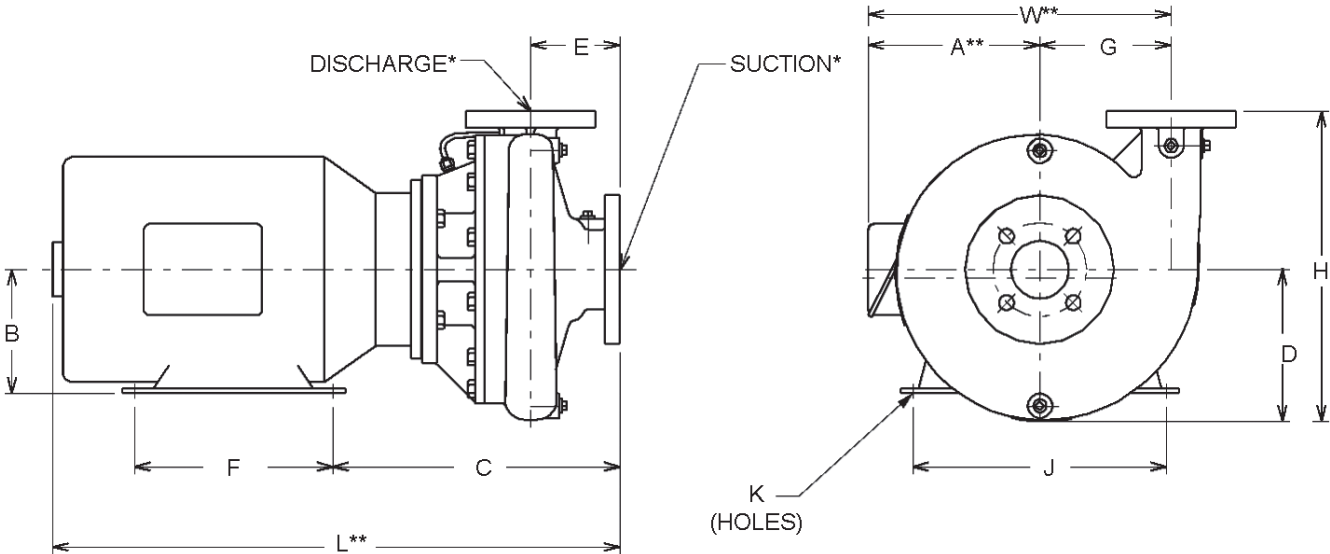

Standard Features

- Cast Iron Construction
- Viton® Silicon Carbide/Carbon Mechanical Seal
- Stainless Steel Precision Cast Dynamically Balanced Impeller
- 6" x 4" 125 Lb. 8-Bolt Flanged Suction Port & 4-Bolt Flanged Discharge Port
- 1/4" NPT Gauge Taps on Suction & Discharge Ports for System Monitoring
- Stainless Steel Shaft Sleeve to Protect Motor Shaft
- Maximum Casing Pressure 175 PSI
- Maximum Temperature 200° F
- Includes Seal Flush/Air Relief Valve
- Front Drain Plugs
- 1750 RPM TEFC JM NEMA Frame IE2/EPAC Energy Efficient Motors