

# 1750 RPM Straight Centrifugal Pump

Model 4201-95



- **Cast Iron Construction**
- **Silicon Bronze Precision Cast Dynamically Balanced Impeller**
- **Viton® Silicon Carbide/Carbon Mechanical Seal**
- **Bronze Case Wear Ring**
- **2" x 1.5" NPT Ports**
- **Pull-From-Rear Design Permits Easy Servicing Without Disturbing Piping**
- **1/4" NPT Gauge Taps on Suction & Discharge Ports For System Monitoring**
- **Bronze Shaft Sleeve to Protect Motor Shaft**
- **Maximum Casing Pressure 175 PSI**
- **Maximum Temperature 200° F**
- **Includes Seal Flush/Air Relief Valve**
- **Front Drain Plugs**
- **TEFC JM NEMA Frame IE2/EPAC Energy Efficient Motors**

The AMT Cast Iron 1750 RPM Solids Handling End Suction Centrifugal pump delivers performance that minimizes operation and energy costs. Built to last, each pump features a precision cast bronze impeller that is dynamically balanced to minimize vibration and maximize motor bearing life. Pull- from-rear design simplifies maintenance without disturbing piping connection. Gauge taps at the suction and discharge ports allow for system monitoring. Maximum 1/4" diameter solids handling and optional seal flush/air relief valve is available for vertical installations. **Pumps require a flooded suction and positive suction pressure.**

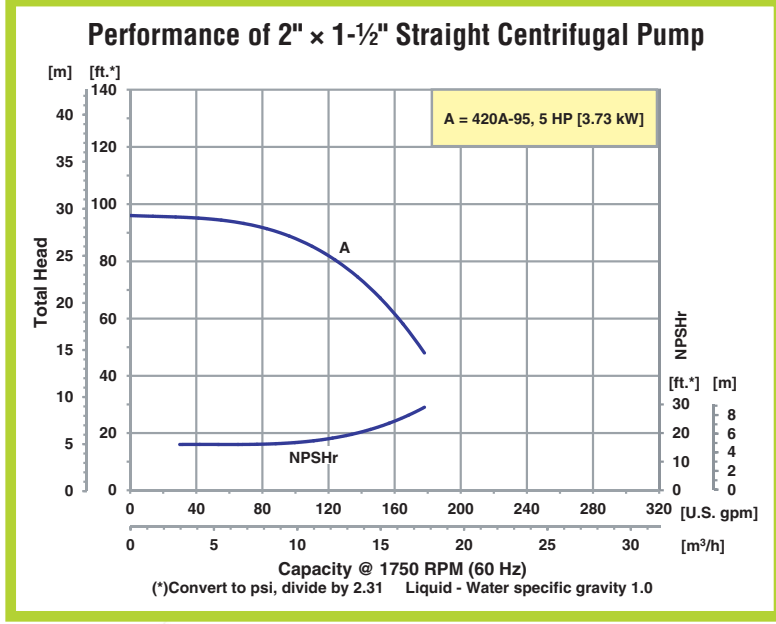

John M. Ellsworth Co., Inc.

P.O. Box 240072  
8700 West Bradley Road  
Milwaukee, WI 53224

800-333-3331 PHONE

info@jmesales.com E-MAIL  
www.JMEsales.com WEB

## Pump Dimensional & Specification Data

Model	Curve	HP	PH	Frame	ENC	Voltage @ 60 Hz +	Full Load Amps	SUC*	DIS*	A**	B	C	D	E	F	G	J	L**	W**	H	Ship Wt. (Lbs.)
4201-95	A	5	3	182JM	TEFC	208-230/460	22/11	2	1-1/2	7.5 [19.1]	4.5 [11.4]	10.9 [27.8]	6.3 [16.0]	3.8 [9.7]	5.5 [14.0]	5.5 [14.0]	7.5 [19.1]	21.1 [53.7]	16.0 [40.6]	12.8 [32.5]	215

(\*) Standard NPT (Female) pipe thread.

(\*\*) This dimension may vary due to motor manufacturer's specifications.

(+) 3-Phase motors can also operate on 50 Hz. (this will change full load amps, service factor and RPM)

NOTE: Dimensions are in inches (centimeters) and have a tolerance of  $\pm 1/4$ ".

NOTE: Electric supply for **ALL** motors must be within  $\pm 10\%$  of nameplate voltage rating (e.g 230V  $\pm 10\%$ =207 to 253)

Maximum Solids Handling Capacity: 1/4" Diameter

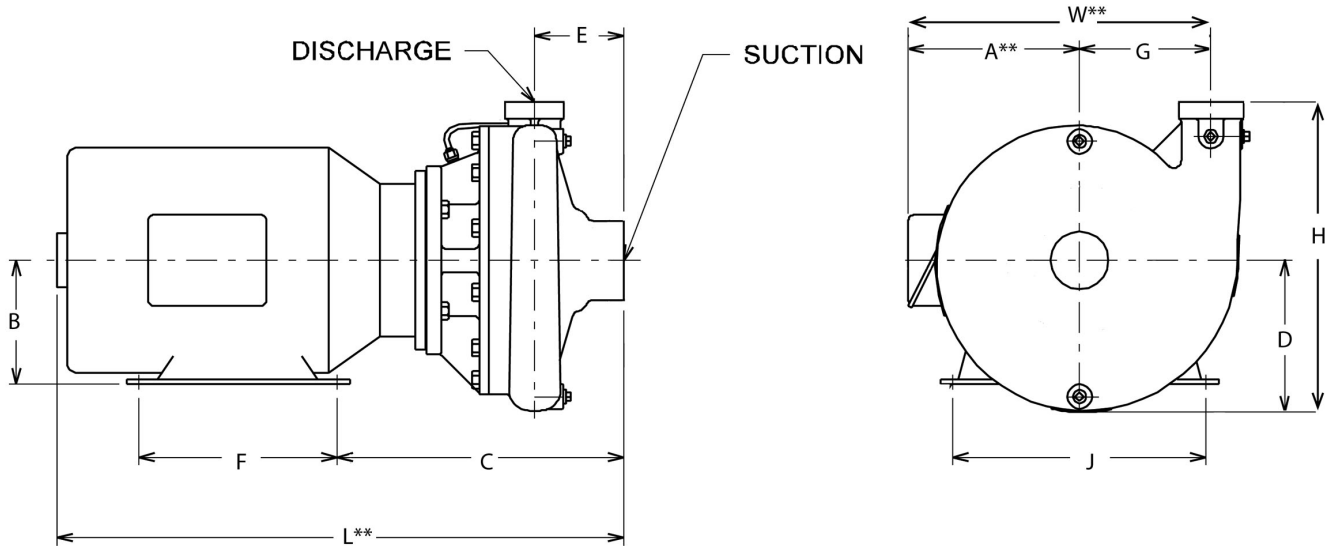

## Standard Features

- Cast Iron Construction
- Viton® Silicon Carbide/Carbon Mechanical Seal
- Silicon Bronze Precision Cast Dynamically Balanced Impeller
- Bronze Case Wear Ring
- 2" x 1.5" NPT Ports
- 1/4" NPT Gauge Taps on Suction & Discharge Ports for System Monitoring
- Bronze Shaft Sleeve to Protect Motor Shaft
- Maximum Casing Pressure 175 PSI
- Maximum Temperature 200° F
- Includes Seal Flush/Air Relief Valve
- Front Drain Plugs
- 1750 RPM TEFC JM NEMA Frame IE2/EPAC Energy Efficient Motors