

SD and XD Series Hose Reels

313431P
EN

For dispensing air, water, antifreeze, windshield washer solvent, transmission fluid, oil and grease. For professional use only.

Not approved for use in European explosive atmosphere locations.

A complete list of Models, including Maximum Working Pressure, begins on page 2.



Important Safety Instructions

Read all warnings and instructions in this manual. Save these instructions.

**SD Series
(HP Models)**

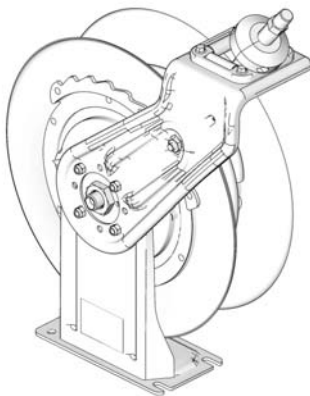

**XD Series
(HS Models)**

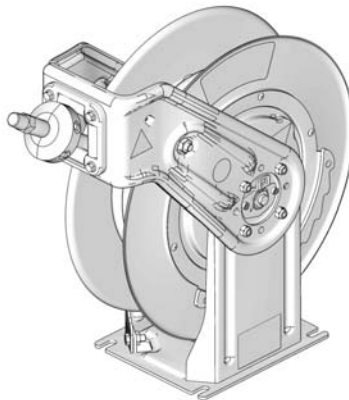

**XD Series
(HN Models)**

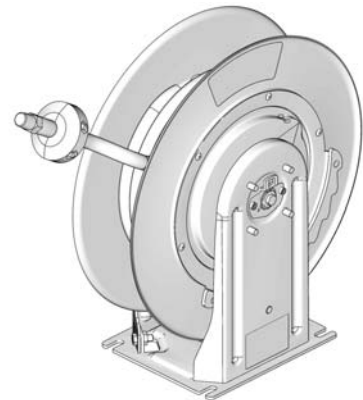

Table of Contents

Models	2	Technical Data	38
Warnings	6	Mounting Channel Dimensions	42
Typical Installation	8	Graco Hose Reel Warranty	48
Installation	9	Graco Information	48
Maintenance	20		
Parts SD Series	25		
Parts XD Series; HS Models	28		
Parts XD Series; HN Models	31		
Kits	33		

Models

SD Series (Part List page 25)

*Each HP Model hose reel shown in the tables below is available in several colors. The last character of each Model No. indicates the hose reel color. For example: A = white + NPT, B = metallic blue + NPT, C = red + NPT, D = black + NPT, E = Mercedes blue + NPT, F = yellow + NPT, J = white + BSPP, K = metallic blue + BSPP, L = red + BSPP, M = black + BSPP, N = yellow + BSPP, P = white + BSPT, R = metallic blue + BSPT, S = red + BSPT, T = black + BSPT, or U = yellow + BSPT. (Other color choices may be available from your Graco Distributor.) On the table below this last character is represented by the generic # symbol. For example, to show the complete model number for a white HPL56# model hose reel, the # symbol in the table is replaced with "A". The complete model number is: HPL56A.

Model No.*	Size	Type	Pressure Rating psi (MPa, bar)	Media	Connection Size		Line Size (inches)	Length (feet)
					Inlet	Outlet		
HPL2D#	10	Bare	300 (2.1, 20.7)	Air/Water	3/8 npsm(m) 3/8 bspp(m)	1/2 npsm(f) 1/2 bspp(f)	3/8	50
HPL6D#	20	Bare	300 (2.1, 20.7)	Air/Water	1/2 npsm(m) 1/2 bspp(m)	1/2 npsm(f) 1/2 bspp(f)	1/2	50
HPL23#	10	Hose	300 (2.1, 20.7)	Air/Water	1/2 npsm(m) 1/2 bspp(m)	3/8 npt(m) 3/8 bspp(m) 3/8 bspt(m)	3/8	35
HPL25#	10	Hose	300 (2.1, 20.7)	Air/Water	1/2 npsm(m) 1/2 bspp(m)	3/8 npt(m) 3/8 bspp(m) 3/8 bspt(m)	3/8	50
HPL56#	20	Hose	300 (2.1, 20.7)	Air/Water	1/2 npsm(m) 1/2 bspp(m)	3/8 npt(m) 3/8 bspp(m) 3/8 bspt(m)	3/8	65
HPL5J#	20	Hose	300 (2.1, 20.7)	Air/Water	1/2 npsm(m) 1/2 bspp(m)	3/8 npt(m) 3/8 bspp(m) 3/8 bspt(m)	3/8	65
HPL33#	10	Hose	300 (2.1, 20.7)	Air/Water	1/2 npsm(m) 1/2 bspp(m)	1/2 npt(m) 1/2 bspp(m) 1/2 bspt(m)	1/2	35
HPL65#	20	Hose	300 (2.1, 20.7)	Air/Water	1/2 npsm(m) 1/2 bspp(m)	1/2 npt(m) 1/2 bspp(m) 1/2 bspt(m)	1/2	50
HPL6H#	20	Hose	300 (2.1, 20.7)	Air/Water	1/2 npsm(m) 1/2 bspp(m)	1/2 npt(m) 1/2 bspp(m) 1/2 bspt(m)	1/2	50
HPM3B#	10	Bare	2000 (14, 138)	Oil	1/2 npsm(m) 1/2 bspp(m)	1/2 npsm(f) 1/2 bspp(f)	1/2	35
HPM6D#	20	Bare	2000 (14, 138)	Oil	1/2 npsm(m) 1/2 bspp(m)	1/2 npsm(f) 1/2 bspp(f)	1/2	50
HPM33#	10	Hose	2000 (14, 138)	Oil	1/2 npsm(m) 1/2 bspp(m)	1/2 npt(m) 1/2 bspp(m) 1/2 bspt(m)	1/2	35
HPM65#	20	Hose	2000 (14, 138)	Oil	1/2 npsm(m) 1/2 bspp(m)	1/2 npt(m) 1/2 bspp(m) 1/2 bspt(m)	1/2	50
HPM6H#	20	Hose	2000 (14, 138)	Oil	1/2 npsm(m) 1/2 bspp(m)	1/2 npt(m) 1/2 bspp(m) 1/2 bspt(m)	1/2	50
HPH1D#	10	Bare	5000 (35, 344.7)	Grease	3/8 npsm(m) 3/8 bspp(m)	3/8 npsm(f) 3/8 bspp(f)	1/4	50
HPH5D#	20	Bare	5000 (35, 344.7)	Grease	3/8 npsm(m) 3/8 bspp(m)	3/8 npsm(f) 3/8 bspp(f)	3/8	50

Model No.*	Size	Type	Pressure Rating psi (MPa, bar)	Media	Connection Size		Line Size (inches)	Length (feet)
					Inlet	Outlet		
HPH15#	10	Hose	5000 (35, 344.7)	Grease	3/8 npsm(m) 3/8 bspp(m)	1/4 npt(m) 1/4 bspp(m) 1/4 bspt(m)	1/4	50
HPH23#	10	Hose	4800 (33, 331)	Grease	3/8 npsm(m) 3/8 bspp(m)	1/4 npt(m) 1/4 bspp(m) 1/4 bspt(m)	3/8	35
HPH55#	20	Hose	4800 (33, 331)	Grease	3/8 npsm(m) 3/8 bspp(m)	1/4 npt(m) 1/4 bspp(m) 1/4 bspt(m)	3/8	50
HPH5H#	20	Hose	4800 (33, 331)	Grease	3/8 npsm(m) 3/8 bspp(m)	1/4 npt(m) 1/4 bspp(m) 1/4 bspt(m)	3/8	50

XD Series (Parts List page 28)





**Each HS or HN Model hose reel shown in the table below is available in either white, metallic blue or yellow. The last character of each Model No. indicates the hose reel color. For example: A = white + NPT, B = metallic blue + NPT, F = yellow + NPT, J = white + BSPP, K = metallic blue + BSPP, N = yellow + BSPP, P= white + BSPT, R = metallic blue + BSPT, or U = yellow + BSPT. (Other color choices may be available from your Graco Distributor.) On the table below this last character is represented by the generic # symbol. For example to show the complete model number for a white HSL2D# model hose reel, the # symbol in the table is replaced with "A". The complete model number is: HSL2DA.

Model No.**	Size	Type	Pressure Rating psi (MPa, bar)	Media	Connection Size		Line Size (inches)	Length (feet)
					Inlet	Outlet		
HSL2D#	10	Bare	300 (2.1, 20.7)	Air/Water	1/2 npsm(m) 1/2 bspp(m)	3/8 npsm(f) 3/8 bspp(f)	3/8	50
HSL6D#	20	Bare	300 (2.1, 20.7)	Air/Water	1/2 npsm(m) 1/2 bspp(m)	1/2 npsm(f) 1/2 bspp(f)	1/2	50
HSL25#	10	Hose	300 (2.1, 20.7)	Air/Water	1/2 npsm(m) 1/2 bspp(m)	3/8 npt(m) 3/8 bspp(m) 3/8 bspt(m)	3/8	50
HSL33#	10	Hose	300 (2.1, 20.7)	Air/Water	1/2 npsm(m) 1/2 bspp(m)	1/2 npsm(m) 1/2 bspp(m) 1/2 bspt (m)	1/2	35
HSL56#	20	Hose	300 (2.1, 20.7)	Air/Water	1/2 npsm(m) 1/2 bspp(m)	3/8 npt(m) 3/8 bspp(m) 3/8 bspt(m)	3/8	65
HSL65#	20	Hose	300 (2.1, 20.7)	Air/Water	1/2 npsm(m) 1/2 bspp(m)	1/2 npt(m) 1/2 bspp(m) 1/2 bspt(m)	1/2	50
HSM3B#	10	Bare	2000 (14, 138)	Oil	1/2 npsm(m) 1/2 bspp(m)	1/2 npsm(f) 1/2 bspp(f)	1/2	35
HSM6D#	20	Bare	2000 (14, 138)	Oil	1/2 npsm(m) 1/2 bspp(m)	1/2 npsm(f) 1/2 bspp(f)	1/2	50
HSM33#	10	Hose	2000 (14, 138)	Oil	1/2 npsm(m) 1/2 bspp(m)	1/2 npt(m) 1/2 bspp(m) 1/2 bspt(m)	1/2	35
HSM65#	20	Hose	2000 (14, 138)	Oil	1/2 npsm(m) 1/2 bspp(m)	1/2 npt(m) 1/2 bspp(m) 1/2 bspt(m)	1/2	50
HS15#	10	Hose	5000 (34, 344.7)	Grease	3/8 npsm(m) 3/8 bspp(m)	1/4 npt(m) 1/4 bspp(m) 1/4 bspt(m)	1/4	50
HS1D#	10	Bare	8000 (55, 551.6)	Grease	3/8 npsm(m) 3/8 bspp(m)	3/8 npsm(f) 3/8 bspp(f)	1/4	50
HS5D#	20	Bare	8000 (55, 551.6)	Grease	3/8 npsm(m) 3/8 bspp(m)	3/8 npsm(f) 3/8 bspp(f)	3/8	50
HS55#	20	Hose	4800 (33, 331)	Grease	3/8 npsm(m) 3/8 bspp(m)	1/4 npt(m) 1/4 bspp(m) 1/4 bspt(m)	3/8	50
HNL56#	20	Hose	300 (2.1, 20.7)	Air/Water	1/2 npsm(m)	3/8 npt(m)	3/8	65
HNL65#	20	Hose	300 (2.1, 20.7)	Air/Water	1/2 npsm(m)	1/2 npt(m)	1/2	50

Model No.**	Size	Type	Pressure Rating psi (MPa, bar)	Media	Connection Size		Line Size (inches)	Length (feet)
					Inlet	Outlet		
HNM65#	20	Hose	2000 (14, 138)	Oil	1/2 npsm(m)	1/2 npt(m)	1/2	50
HNH55#	20	Hose	4800 (33, 331)	Grease	3/8 npsm(m)	1/4 npt(m)	3/8	50

Warnings

The following warnings are for the setup, use, grounding, maintenance, and repair of this equipment. The exclamation point symbol alerts you to a general warning and the hazard symbol refers to procedure-specific risk. Refer back to these warnings. Additional, product-specific warnings may be found throughout the body of this manual where applicable.

 WARNING	
	<p>FIRE AND EXPLOSION HAZARD</p> <p>When flammable fluids are present in the work area, such as gasoline and windshield wiper fluid, be aware that flammable fumes can ignite or explode. To help prevent fire and explosion:</p> <ul style="list-style-type: none"> • Use equipment only in well ventilated area. • Eliminate all ignition sources, such as cigarettes and portable electric lamps. • Keep work area free of debris, including rags and spilled or open containers of solvent and gasoline. • Do not plug or unplug power cords or turn lights on or off when flammable fumes are present. • Ground all equipment in the work area. • Use only grounded hoses. • If there is static sparking or you feel a shock, stop operation immediately. Do not use equipment until you identify and correct the problem. • Keep a working fire extinguisher in the work area.
	<p>EQUIPMENT MISUSE HAZARD</p> <p>Misuse can cause death or serious injury.</p> <ul style="list-style-type: none"> • Do not operate the unit when fatigued or under the influence of drugs or alcohol. • Do not exceed the maximum working pressure or temperature rating of the lowest rated system component. See Technical Data in all equipment manuals. • Use fluids and solvents that are compatible with equipment wetted parts. See Technical Data in all equipment manuals. Read fluid and solvent manufacturer's warnings. For complete information about your material, request MSDS forms from distributor or retailer. • Check equipment daily. Repair or replace worn or damaged parts immediately with genuine manufacturer's replacement parts only. • Do not alter or modify equipment. • Use equipment only for its intended purpose. Call your distributor for information. • Route hoses and cables away from traffic areas, sharp edges, moving parts, and hot surfaces. • Do not kink or over bend hoses or use hoses to pull equipment. • Keep children and animals away from work area. • Comply with all applicable safety regulations.
	<p>SKIN INJECTION HAZARD</p> <p>High-pressure fluid from dispense valve, hose leaks, or ruptured components will pierce skin. This may look like just a cut, but it is a serious injury that can result in amputation. Get immediate surgical treatment.</p> <ul style="list-style-type: none"> • Do not point dispense valve at anyone or at any part of the body. • Do not put your hand over the end of the dispense nozzle. • Do not stop or deflect leaks with your hand, body, glove, or rag. • Follow Pressure Relief Procedure in this manual, when you stop spraying and before cleaning, checking, or servicing equipment.

 **WARNING****MOVING PARTS HAZARD**

Moving parts can pinch or amputate fingers and other body parts.

- Keep clear of moving parts.
- Do not operate equipment with protective guards or covers removed.
- Pressurized equipment can start without warning. Before checking, moving, or servicing equipment, follow the **Pressure Relief Procedure** in this manual. Disconnect power or air supply.

**PRESSURIZED EQUIPMENT HAZARD**

Fluid from the gun/dispense valve, leaks, or ruptured components can splash in the eyes or on skin and cause serious injury.

- Follow **Pressure Relief Procedure** in this manual, when you stop spraying and before cleaning, checking, or servicing equipment.
- Tighten all fluid connections before operating the equipment.
- Check hoses, tubes, and couplings daily. Replace worn or damaged parts immediately.

Typical Installation

--	--	--	--	--	--	--

A **ground wire (G)**, **bleed-type master air valve (E)** and **fluid drain valve (H)** are required in your system installation. These components help reduce the risk of serious injury, including electric shock and splashing in your eyes or on the skin.

- The **ground wire** must be connected to the pump grounding lug and to a true earth ground according to your local code.
- The **bleed-type master air valve** relieves air trapped between this valve and the pump after the air is shut off. Trapped air can cause the pump to cycle unexpectedly. Locate the valve close to the pump.
- The **fluid drain valve** assists in relieving fluid pressure in the displacement pump, hose and gun. Triggering the valve to relieve pressure may not be sufficient.

Overhead-Mounted Hose Reel

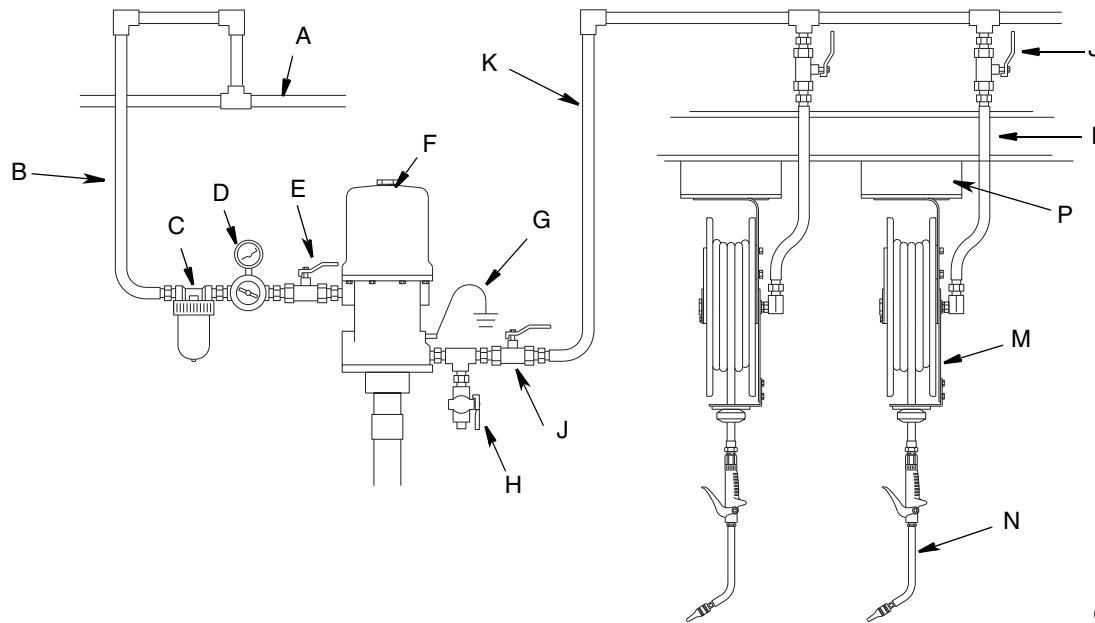

03791

FIG. 1: Typical Installation

Key:

- | | |
|--|--------------------------------|
| A Main air supply line | H Fluid drain valve (required) |
| B Pump air supply line | J Fluid shutoff valve |
| C Air filter | K Fluid line |
| D Air regulator | L Hose reel fluid inlet kit |
| E Bleed-type master air valve (required) | M Hose reel |
| F Pump | N Dispensing valve |
| G Pump grounding wire (required) | P Mounting channel/base |

Installation

The typical installations shown in FIG. 1 is only a guide for selecting and installing a hose reel system. The components shown are the minimum requirements for all systems. However, it is not an actual system design. Contact your Graco distributor for assistance in designing a system to suit your needs.

NOTE: The air and fluid accessories required for your pump must be properly sized to that pump. Refer to your specific pump manual for selecting pump accessories.

Air Line Components



Install the following components in the order shown in FIG. 1, using adapters if necessary.

- **Bleed-type Master Air Valve (E):** locate downstream from the air regulator and for easy access from the pump.
- **Air Regulator (D):** controls pump speed and outlet pressure by adjusting the air pressure to the pump. Locate the regulator close to the pump but upstream from the bleed-type master air valve.
- **Air Line Filter (C):** removes harmful dirt and moisture from the compressed air supply.

Fluid Line Components

Install the following components in the order shown in FIG. 1, using adapters if necessary.

- **Fluid Drain Valve (H):** install the drain valve pointing down but so the handle points up when the valve is open.
- **Fluid Shutoff Valve (J):** shuts off fluid to hose reel.
- **Dispensing Valve (N):** dispenses the fluid or air.

Required Components

Be sure you have the following components before you begin the installation.

- **Hose inlet kit (L)**
- **Reel mounting bases, mounting brackets and mounting channels (P)**
- **Dispense valves (N)**

Installation Mounting Options

Mounting Adapter Kit for Replacing Series 500 Reels

A Mounting Adapter Kit is available for installing an XD Series Hose Reel in the same location that a Series 500 Hose Reel was previously installed. Order Graco Kit No. 24A224. See FIG. 2 and page 36.

A = Original Series 500 holes in mounting surface.

B = Holes on the bottom of adapter bracket, predrilled to match original Series 500 hole configuration (A).

C = Holes on the top of the adapter bracket, predrilled to match new XD Series Hose Reel base.

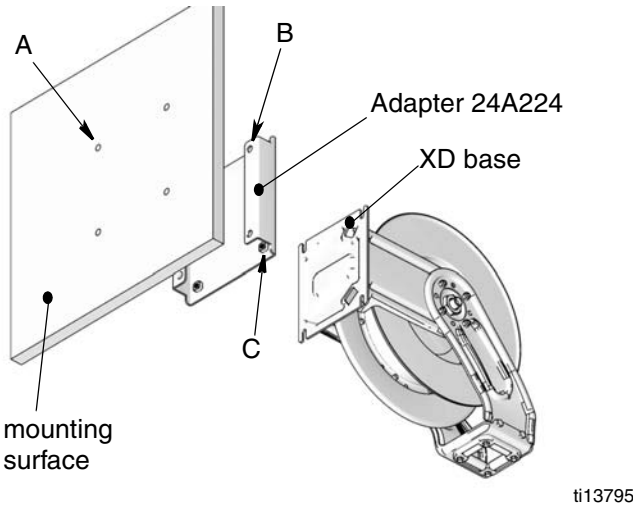

FIG. 2

All Mountings

<p>To reduce the risk of injury, be sure the mounting surface is strong enough to support the reels, weight of the lubricants and stress caused by hard pulls on the service hoses. See Technical Data, page 38 for weights of hose reel assemblies.</p>						

NOTE: Reels perform best when arm allows hose to pull straight off the spool as shown in FIG. 3.

HP, HS Models

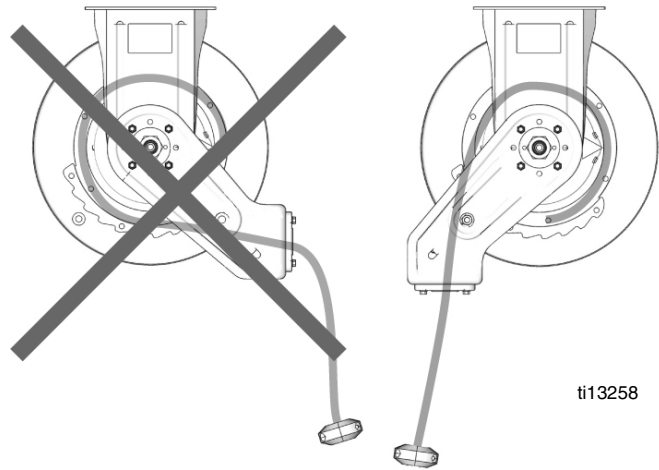

Panel Mount (HN) Models

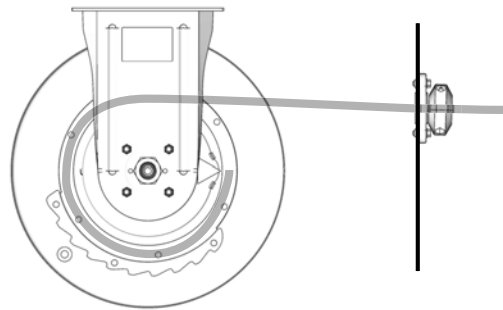

FIG. 3

NOTE: Always use all 4 large flat washers with 4 bolts to mount the hose reel pedestal to any surface.

All Models

Select the reel bank mounting location.

- For high ceilings, suspend a suitable support structure for the reels, so the hoses will be long enough to reach your service area.
- A reel bank mounted in a one-lift service bay should be at least 6-ft (1.9m) from the center line of the lift (FIG. 6).
- In a one-lift bay, mount the reel bank at least 6 feet (1.9 m) from the center line of the lift. In a two-lift bay, mount the bank equal distance between the lifts.
- A bank of all motor oil reels should be mounted about 5 ft (1.5m) from the center of the lift, toward the front of the lift rails (FIG. 6).

HP or HS Models Only

1. Determine the desired position of the roller support arm (a) (FIG. 4).

The hose reel is factory-assembled and shipped with the roller support arm (a) in either the AA or EE position:

- AA for HP Models that do not have an H or J in the 5th number position of the model number
- EE for HP Models showing an H or J in the 5th number position of the model number
- EE for all HS Models

If shipping position AA or EE is desired, skip step 2.

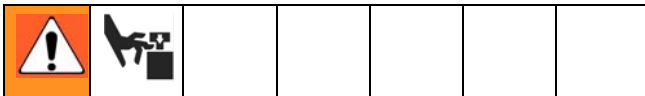

2. To reposition roller support arm to any other position than the Ship Position (AA or EE):

- **HP Model Reels**
 - a. Secure spool against pedestal with C-Clamp.
 - b. Remove 4 nuts (b) and rotate arm (a) to desired position.
 - c. Check pawl to make sure it is not wedged. See FIG. 5.

- **HS Model Reels**

- a. Secure spool against pedestal with C-Clamp.
- b. Remove 8 nuts (b) (4 from each side) and rotate arm (a) to desired position.
- c. Check pawl to make sure it is not wedged. See FIG. 5.

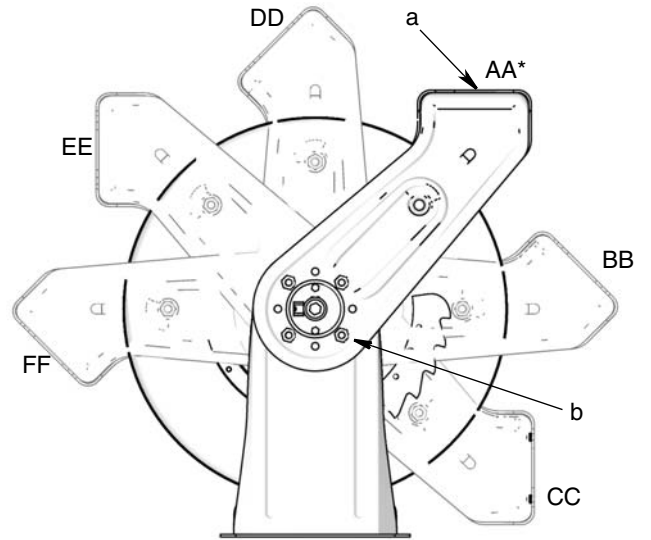

AA Shipping Position

ti12199a

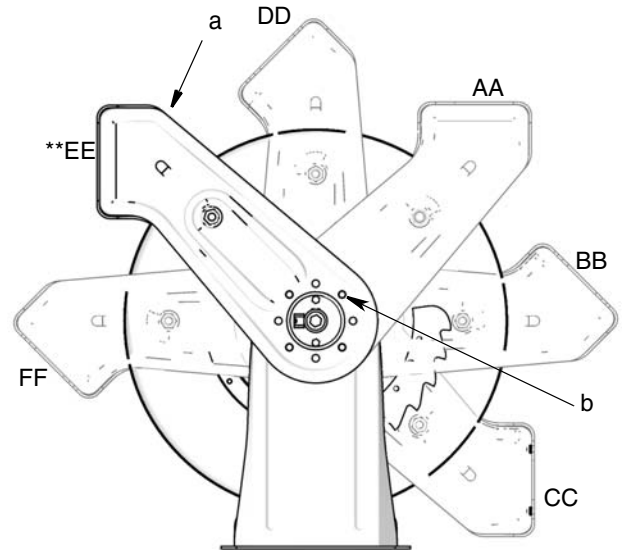

EE Shipping Position
FIG. 4

ti13394

Overhead Installations

To reduce the risk of injury, when you are mounting a hose reel overhead, always use a lift truck.						

HS Models Only

1. Reposition guide arm to position AA. See Step 2 for HS Model Reels (above).

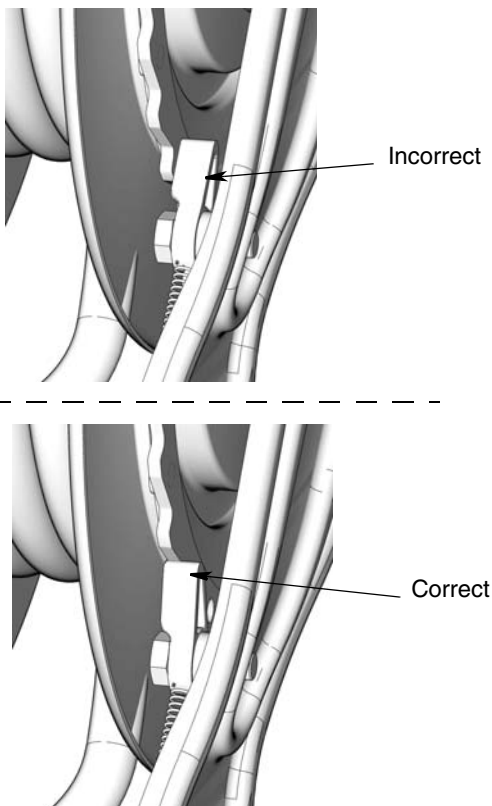
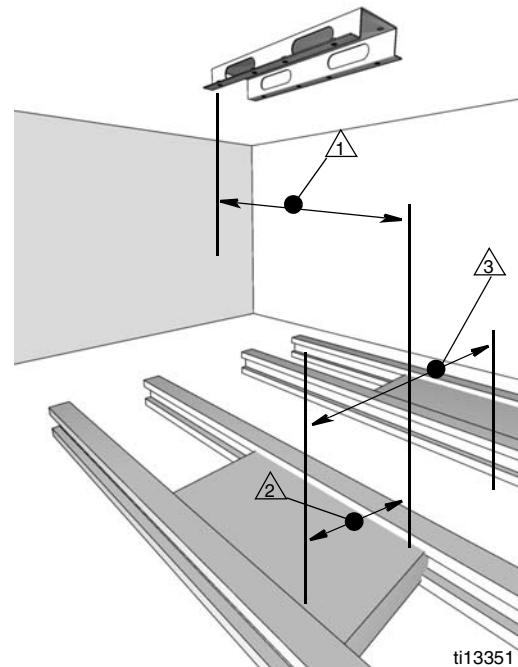

FIG. 5

2. Position the hose reel so the pedestal is facing up.
3. Using the lift truck, raise the reel as close to the mounting location as possible.

4. Bolt hose reel to its mounting. **Be sure it is secure before lowering the lift truck.**



- ① 5 ft (1.5m) minimum for motor oil
- ② 6 ft (1.9m) minimum for 1 lift
- ③ Center between two lifts

FIG. 6

5. Connect inlet supply line to inlet hose of the reel. See Hose Installation, page 17.

NOTE: None of the hose reels listed in this manual come with a Hose Inlet Kit.

6. Flush system.

To avoid contaminating the fluid with line-scale, chips or other installation debris, before installing meter or dispense valve to end of hose, flush the equipment with a compatible solvent such as Stoddard solvent or mineral spirits.

- a. Secure the end of the hose in a waste bucket.
- b. Blow out entire lubricant supply line with air.
- c. Pump solvent through line until fluid runs clear and is debris free.

- d. Pump lubricant through line until all solvent is flushed out.
- 7. Re-position hose stop if needed so hose extends far enough for all operators to reach dispensing valve and tighten nuts to securely hold hose stop in place.
- 8. Install meter or dispense valve to end of hose following instructions provided with the dispense equipment. (NOTE: If installing an enclosure around hose reel, install the enclosure before installing dispense valve or meter to hose end.)
- 9. Adjust spring tension, page 18.

Other Mounting Options

Ceiling Mounting Without an I-Beam - Open Channel (All Models)

- For HP Model Reels Order Mounting Kit: 24A934, 24A935, 24A936, 24A937, 24A938 or 24A939. For HS or HN Model Reels Order Mounting Kit: 24A219, 24A220, 24A221, 24A222.
- See page 42 for mounting channel dimensions.

HP Models: Open Channel Mounting Kits								HS Models: Mounting Kits			
FN	Description	24A934 1 Reel	24A935 2 Reels	24A936 3 Reels	24A937 4 Reels	24A938 5 Reels	24A939 6 Reels	24A219 1 Reel	24A220 2 Reels	24A221 3 Reels	24A222 6 Reels
101	PLATE, hold down	1	2	3	4	5	6				
102	SCREW, 3/8" - 16 x 5/8"	5	10	15	20	25	30	4	8	12	24
103	WASHER, lock, 3/8"	5	10	15	20	25	30	4	8	12	24
104	BASE, reel	1	2	3	4	5	6				
105	BASE, reel, channel	1	1	1	1	1	1	1	1	1	1

1. Install the mounting channel (105) and (HP Models) base plate (104) as shown in FIG. 7.

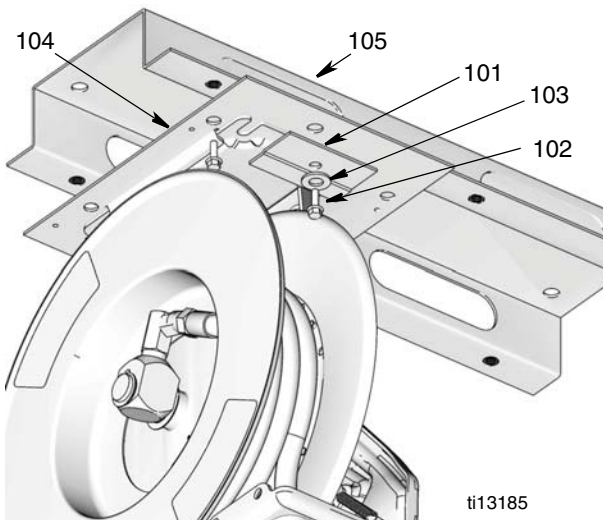

FIG. 7



2. Slide hose reel into the base plate (104) and install the hold-down plate (101), washer (103) and cap-screw (102). Tighten the screw firmly (FIG. 7, page 13).
3. If you are installing permanent supply lines, drill 1.5 in. (38 mm) diameter holes through the ceiling toward the inlet side of the reels.
4. Continue installation following steps 5 - 9 of Over-head Installations instructions, beginning on page 12.

Ceiling Mounting Directly to an I-Beam - HP Models Only

- Using the template (B), provided, drill holes in the I-Beam (C) (FIG. 8).

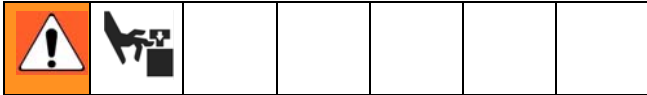

- Bolt reel to I-Beam.
- If you are installing permanent supply lines, drill 1.5 in. (38 mm) diameter holes through the ceiling toward the inlet side of the reels.

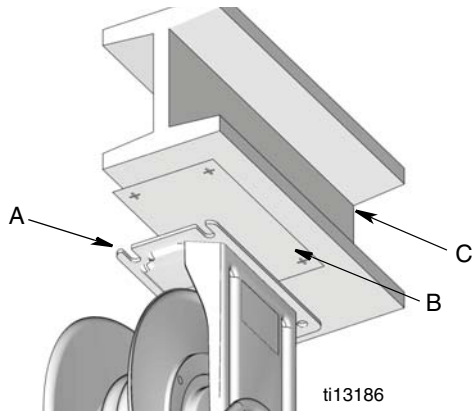

FIG. 8

- Continue installation following steps 5 - 9 of Overhead Installations instructions, beginning on page 12.

Ceiling Mounting to I-Beam without Drilling Holes - All models

(Order Mounting Bracket Kit: 204741 for open or enclosed reels.)

NOTE: For mounting 1-3 reels, two kits are required. For mounting 4-6 reels, three kits are required.

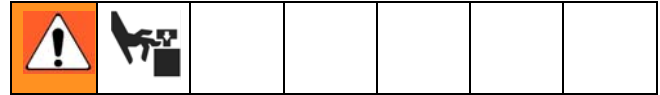

FN	Description	Qty
201	WASHER, lock, 1/2"	2
202	SCREW, 1/2" - 13 x 1"	2
203	SCREW, 1/2" - 13 x 1-3/4"	2
204	NUT 1/2" - 13	2
205	NUT, spring clamp (not shown)	2
206	CLAMP, beam	2
207	CHANNEL, unistrut	1

- Secure mounting brackets (D) to the channel. Use two mounting brackets for each 1- to 3 capacity mounting channel (103). (Use 3 brackets for 4-6 reel channels.)
- Position the adjustable clamps (206) of the mounting brackets over the I-Beam (A), and tighten them securely (FIG. 9).
- HP Model Reels only** (FIG. 7, page 13): Slide hose reel onto the base plate (104) and install the hold-down plate (101), washer (103) and capscrew (102). Tighten the screw firmly.
- If you are installing permanent supply lines, drill 1.5 in. (38 mm) diameter holes through the ceiling toward the inlet side of the reels.

5. Connect inlet supply line to inlet hose of the reel. See Hose Installation, page 17.

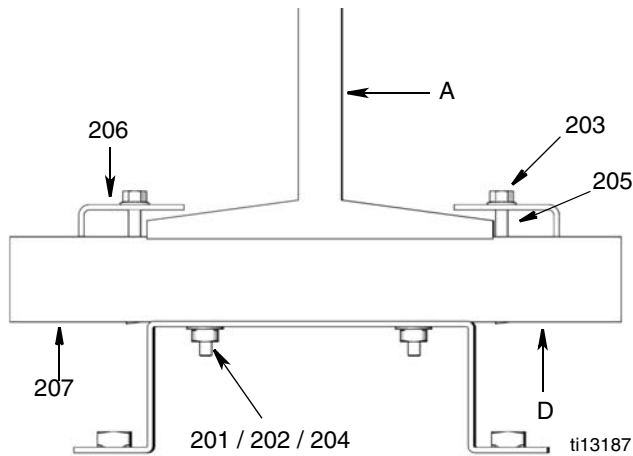
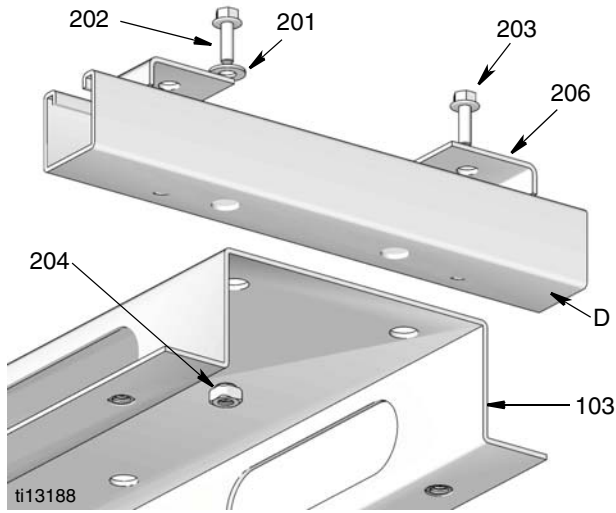

FIG. 9

NOTE:

- The hose reels listed in this manual do not come with a Hose Inlet Kit.

6. Flush system.

To avoid contaminating the fluid with line-scale, chips or other installation debris, before installing meter or dispense valve to end of hose, flush the equipment with a compatible solvent such as Stoddard solvent or mineral spirits.

- a. Secure the end of the hose in a waste bucket.
- b. Blow out entire lubricant supply line with air.

- c. Pump solvent through line until fluid runs clear and is debris free.

- d. Pump lubricant through line until all solvent is flushed out.

7. Position hose stop so hose extends far enough for all operators to reach dispensing valve and tighten nuts to securely hold hose stop in place.

8. Install meter or dispense valve to end of hose following instructions provided with the dispense equipment. (NOTE: If installing an enclosure around hose reel, install the enclosure before installing dispense valve or meter to hose end.)

9. Adjust spring tension, page 18.

Wall Mounting

(For HP Model Reels Order Mounting Kit: 24A934, 24A935, 24A936, 24A937, 24A938 or 24A939.
For HS or HN Model Reels Order Mounting Kit: 24A219, 24A220, 24A221, 24A222.)

HP Models: Open Channel Mounting Kits								HS / HN Models: Mounting Kits			
FN	Description	24A934 1 Reel	24A935 2 Reels	24A936 3 Reels	24A937 4 Reels	24A938 5 Reels	24A939 6 Reels	24A219 1 Reel	24A220 2 Reels	24A221 3 Reels	24A222 4 Reels
101	PLATE, hold down	1	2	3	4	5	6				
102	SCREW, 3/8" x 16 x 5/8"	5	10	15	20	25	30	4	8	12	24
103	WASHER, lock,3/8"	5	10	15	20	25	30	4	8	12	24
104	BASE, reel	1	2	3	4	5	6				
105	BASE, reel channel	1	1	1	1	1	1	1	1	1	1

- Adjust guide arm to desired position, FIG. 4, page 11.
- Select the reel bank mounting location. Mount the reel to a wall, using the provided template (B) for laying out the holes you drill.

You can mount the base plate (104) to the wall for easier installation and removal of the hose reel for servicing (FIG. 10).

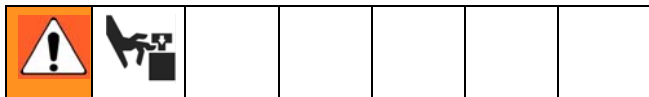

- Slide hose reel onto the base plate (104) and install the hold-down plate (101), washer (103) and cap-screw (102). Tighten the screw firmly (FIG. 10).

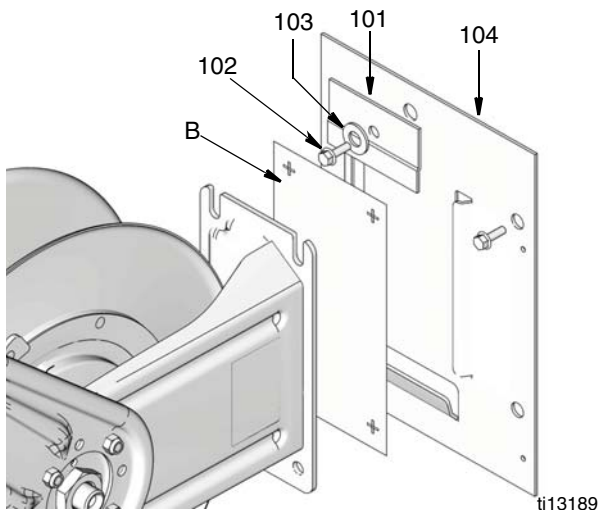

FIG. 10

- Connect inlet supply line to inlet hose of the reel. See Hose Installation, page 17.

NOTE:

- The hose reels listed in this manual do not come with a Hose Inlet Kit.

5. Flush system.

To avoid contaminating the fluid with line-scale, chips or other installation debris, before installing meter or dispense valve to end of hose, flush the equipment with a compatible solvent such as Standard solvent or mineral spirits.

- Secure the end of the hose in a waste bucket.
 - Blow out entire lubricant supply line with air.
 - Pump solvent through line until fluid runs clear and is debris free.
 - Pump lubricant through line until all solvent is flushed out.
- Position hose stop so hose extends far enough for all operators to reach dispensing valve.
 - Insert screws through hose stop and tighten nuts to securely hold hose stop in place.
 - Install meter or dispense valve to end of hose following instructions provided with the dispense equipment.

NOTE: If installing an enclosure around hose reel, install the enclosure before installing dispense valve or meter to hose end.

- Adjust spring tension, page 18.

Hose Installation

Installing a Hose on a Bare Reel

1. Locate length of your hose in table below. Note how many times you must turn the spring to properly pre-set spring tension.

Hose Length	No. of Reel Turns
35 ft (10.7 m)	17
50 ft. (15.2 m)	21
65 ft. (19.8 m)	23

2. Before you install hose, attach a C-Clamp (D) to reel flange to help prevent the reel from unintentionally becoming unlatched and spinning freely. (FIG. 11).

<p>Never allow the reel to spin freely. Doing so causes the hose reel to spin out of control, which could cause serious injury if you are hit by the hose or other moving parts</p>						

3. Place a piece of tape on the side of the reel flange to use as a visual reference to help you count the number of reel turns.

<p>Always wear heavy gloves when you adjust spring tension to protect your hands from being cut on hose reel.</p>						

4. Wearing heavy gloves, firmly grab the outside edge of the reel flange with both hands. Wind the reel the proper number of turns (See reference table following Step 1), rotating it in the direction shown in FIG. 11.
 - Stop only at latching locations.
 - Stop reel where there is access to hose swivel (A) (FIG. 12) and where reel is securely latched.

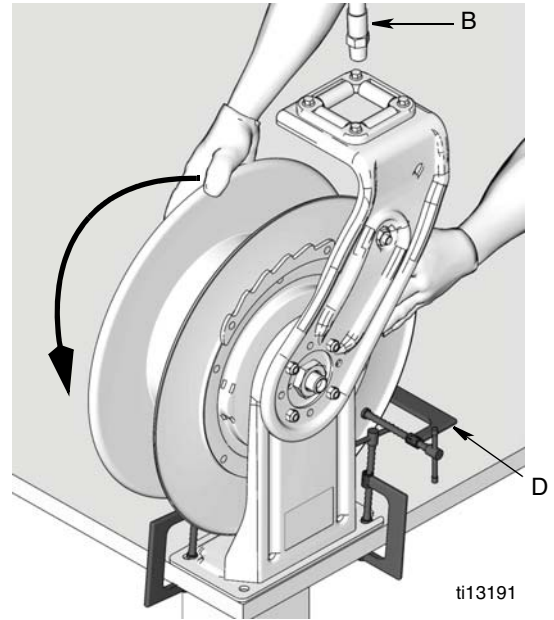

FIG. 11

5. Uncoil and extend hose.
6. Install hose stop (C) to end of hose. If hose has a warning tag (F), hose stop should be installed on the same end of the hose as the warning tag.

NOTE: If hose is equipped with a kink guard, this end must be on the same end as the hose stop.

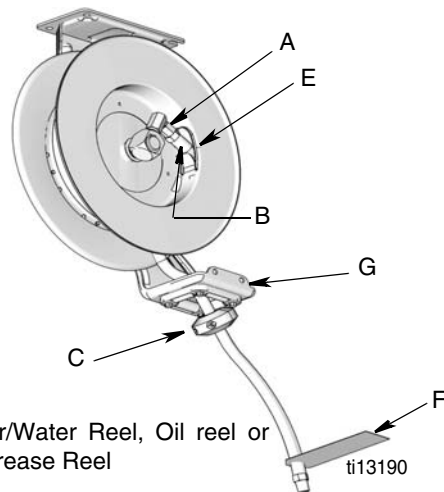

FIG. 12

7. Run the end of the hose (B) through the hose guide (G) and then the hole (E) in reel (FIG. 12).

8. Attach hose end (B) to hose reel swivel (A). Then carefully remove C-Clamp (D) (FIG. 11).

9. Pull hose hard enough to release the latch, and slowly allow the hose to retract.

10. Flush system.

To avoid contaminating the fluid with line-scale, chips or other installation debris, before installing meter or dispense valve to end of hose, flush the equipment with a compatible solvent such as Standard solvent or mineral spirits.

- a. Secure the end of the hose in a waste bucket.
- b. Blow out entire lubricant supply line with air.
- c. Pump solvent through line until fluid runs clear and is debris free.

d. Pump lubricant through line until all solvent is flushed out.

11. Reposition hose stop if needed so hose extends far enough for all operators to reach dispensing valve.

12. Insert screws through hose stop and tighten nuts to securely hold hose stop in place.

13. Install meter or dispense valve to end of hose following instructions provided with the dispense equipment. (NOTE: If installing an enclosure around hose reel, install the enclosure before installing dispense valve or meter to hose end.)

14. Adjust spring tension, page 18.

Increasing and Decreasing Spring Tension

Single Pedestal HP Model Hose Reels

						
<ul style="list-style-type: none"> • The hose reel spring is not a serviceable part. Do not attempt to replace or service the hose reel spring. • The spring is always under great tension and could be propelled with enough force to cause serious injury. • Never allow reel to spin freely. Doing so causes the hose reel to spin out of control, which could cause serious injury if you are hit by the hose valve or other moving parts. • Reel must be bolted securely in place when making adjustments. 						

Increasing Spring Tension

- 1. Pull out hose, 1 to 2 turns and engage latch.
- 2. Pull hose back through hose rollers.
- 3. Wrap a loop of hose onto the reel flange.
- 4. Check the spring tension; the hose must pull out fully and retract fully. Wrap more loops, one at a time around the reel flange until the spring has the desired tension.

NOTE: Do not put so many loops onto the reel that the spring winds up tightly before the hose is fully extended.

Decreasing Spring Tension

Remove loops to decrease tension.

Dual Pedestal HS or HN Model Hose Reels

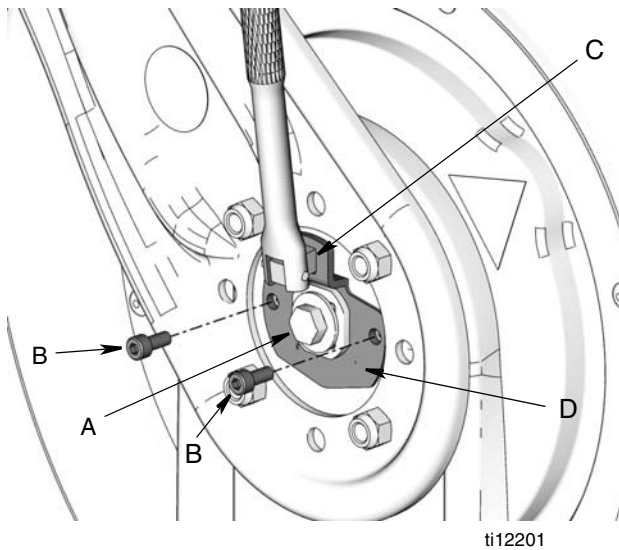

FIG. 13

<ul style="list-style-type: none"> • Never allow the reel to spin freely. Doing so causes the reel to spin out of control, which could cause serious injury if you are hit by a tool or the hose. • Reel must be bolted securely in place when making adjustments. 						

If hose is not retracting sufficiently or is wound too tight, the tension can be increased or decreased using one of the following procedures:

Increasing Spring Tension

(spring is too loose, hose does not retract completely or retraction is sluggish)

1. Loosen screw (A) 3-5 turns. Do not completely remove it.
2. Use a hex wrench to loosen, the two screws (B). Do not completely remove them.
3. Insert a 3/8" square drive breaker bar in opening (C) on the spring adjustment plate (D).
4. While holding the breaker bar securely, completely remove the two screws (B).

5. Firmly grasp the breaker bar with both hands and turn it clockwise one turn at a time to increase (tighten) spring tension.
6. Replace and partially tighten both screws (B). You can now remove the breaker bar. Pull out a section of hose and allow it to retract to test the tension adjustment.
7. If additional tension is required, insert the breaker bar in the bracket again and remove screws (B). Then repeat steps 5 - 6.
8. When you are satisfied with the new setting, tighten screws A and B.

Decreasing Spring Tension

(spring is too tight, hose retracts too fast)

1. Loosen screw (A) 3-5 turns. Do not completely remove it.
2. Use a hex wrench to loosen, the two screws (B). Do not completely remove them.
3. Insert a 3/8" square drive breaker bar in opening (C) on the spring adjustment plate (D).
4. While holding the breaker bar securely, completely remove the two screws (B).
5. Firmly grasp the breaker bar with both hands and turn it counter-clockwise one turn at a time to decrease (loosen) spring tension.
6. Replace and partially tighten both screws (B). You can now remove the breaker bar. Pull out a section of hose and allow it to retract to test the tension adjustment.
7. If additional adjustment is required, insert the breaker bar in the bracket again and remove screws (B). Then repeat steps 5 and 6.
8. When you are satisfied with the new setting, tighten screws A and B.
9. Match holes (e) in end panel (403) to mating holes (f) in side panel. Install and tighten screws (402) to join the end and side panels together.
10. Clean and dry off surface of each end panel. Attach a Graco label (404) to the center of each end panel.
11. Position hose stop so hose extends far enough for all operators to reach dispensing valve.

Maintenance

Pressure Relief Procedure



Follow the Pressure Relief Procedure whenever you see this symbol.



This equipment stays pressurized until pressure is manually relieved. To help prevent serious injury from pressurized fluid, such as skin injection, splashing fluid and moving parts, follow the Pressure Relief Procedure when you stop spraying and before cleaning, checking, or servicing the equipment.

1. Close the supply pump's bleed-type master air valve (required for pneumatic systems).
2. Open the dispensing valve until pressure is fully relieved.
3. Open the fluid valve at the pump fluid outlet. Leave the drain valve open until you are ready to use the system again.

If you suspect that the dispensing valve, extension, or grease fitting coupler is clogged, or that pressure has not been fully relieved after you have followed the steps above, **very slowly** loosen the coupler or hose end coupling to relieve the pressure gradually, then loosen it completely. Then clear the clog.

Replacing Spool - HP models (single pedestal)

A complete list of replacement Spool Kits is available on page 33. Use all new parts included in kit.

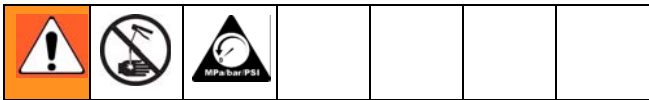

1. **Relieve pressure**, page 20.
2. Release spring tension, page 18.
3. Remove capscrew (102), washer (103) and hold down plate (101). Then slide hose reel out of base plate (104) (FIG. 14).

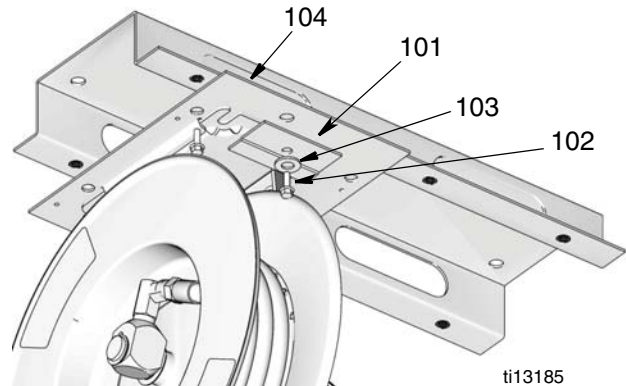

FIG. 14

4. Completely remove hose from spool (5h) and set it aside to reinstall on the new spool.

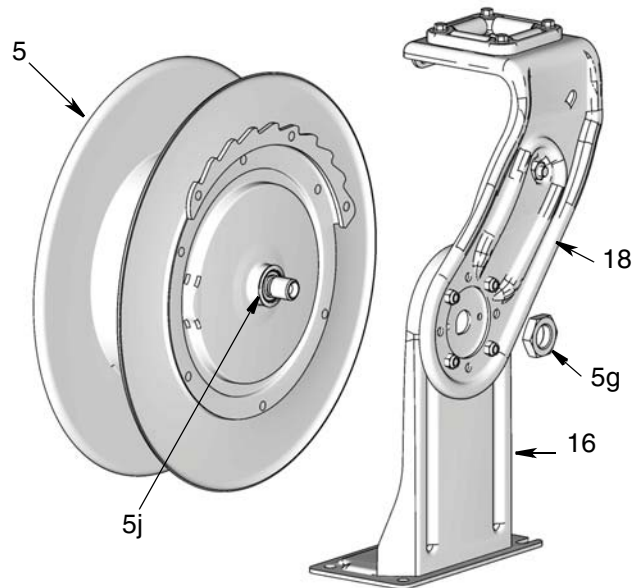

FIG. 15

5. Remove and discard nut (5g).
6. Completely remove guide arm and pedestal assembly (16 / 18) as one piece and set it aside to reinstall on the new spool. These parts do not have to be disassembled.
7. Remove spool assembly (5).

NOTE: Inspect inside of guide arm to make sure washer (5j) is not adhering to the inside of the guide arm. Washer (5j) should be discarded with the old

spool. A new washer (5j) is installed on the new spool and is part of the new spool assembly.

8. Install new spool assembly (5).
9. Install guide arm and pedestal assembly (16 / 18) over spool (5) and install nut (5g). Tighten and torque nut to 85-105 ft. lbs (378 - 467 N.m).
10. Slide hose reel onto the base plate (104) and install the hold-down plate (101), washer (103) and cap-screw (102). Tighten the screw firmly.
11. Install hose on spool following the Hose Installation instructions, page 17.
12. Flush hose following flushing instructions starting with Step 10, page 18.
13. Set spring tension following Increasing and Decreasing Spring Tension instructions on page 18.

Replacing Spool - HS or HN models (dual pedestal)

A complete list of replacement Spool Kits is available on page 33. Use all new parts included in kit.



1. **Relieve pressure**, page 20.
2. Release spring tension, page 19
3. Remove reel from service.
4. Completely remove hose from spool and set it aside to reinstall on the new spool.

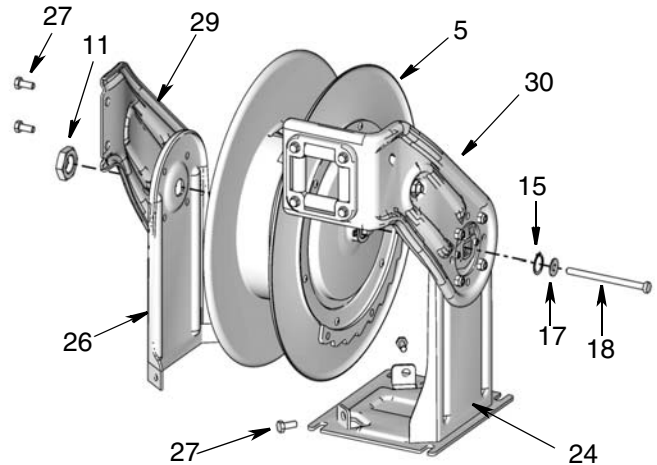

FIG. 16

5. Remove large nut (11) (FIG. 16).
6. Remove two screws (27) holding pedestal (26) to base (24) and two screws (27) holding guide arm (29) to guide arm (30) (FIG. 16).

NOTE: HN models do not have a guide arm. Guide Arm and related parts are not included.

7. Completely remove guide arm and pedestal assembly (26 / 29) and set it aside to reinstall on the new spool (FIG. 16). These parts do not have to be disassembled.

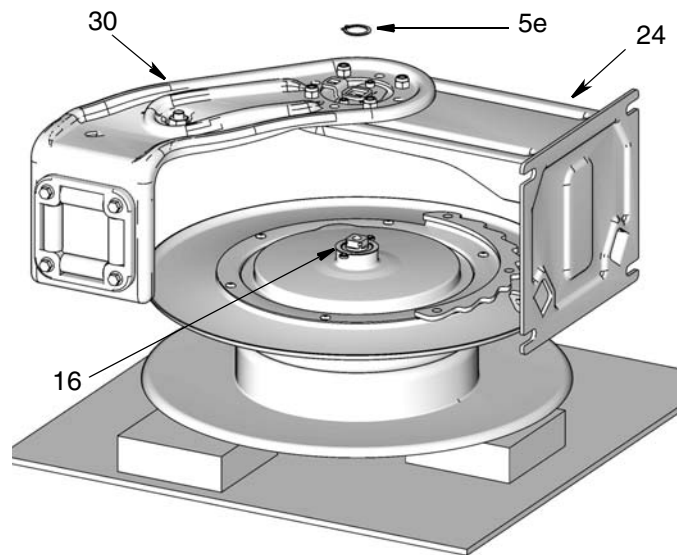

FIG. 17

8. Lay hose reel on its side so you can easily access the guide arm and pedestal (24 / 30). Remove long bolt (18) and washers (15 / 17) (FIG. 16 and FIG. 17).
9. Remove snap ring (5e) (FIG. 17).
10. Remove guide arm and pedestal base (24 / 30) as one piece. These parts do not have to be disassembled.

NOTE: Inspect inside of guide arm to make sure washer (5j) is not adhering to the inside of the guide arm. Washer (5j) should be discarded with the old spool. A new washer (5j) is part of the new swivel assembly.

11. Remove and discard old spool.

To Reassemble Spool:

12. Place new spool (5) on its side on a work bench. Make sure the flat side of the spool faces down on the table and the ratchet side is facing up, as shown in FIG. 17.
13. Position guide arm and pedestal base (24 / 30) assembly over spool. Adjust as needed to correctly align parts.

NOTE: It is easier to reattached the guide arm and pedestal assembly to the spool if the spool is supported and somewhat level. Placing a couple blocks of 1" thick scrap wood under the spool as shown in FIG. 17 (page 21) will help support the spool during the arm installation.

14. Replace snap ring (5e).
15. Install new swivel assembly in spool (see parts page 28).
16. Install washers (15 / 17) and long bolt (18), but do NOT tighten bolt.
17. Turn the spool over.
18. Install guide arm and pedestal assembly (26 / 29) over swivel assembly and spool.

Note shape (a) of swivel assembly end shown in FIG. 18 and the correct alignment of swivel to the key hole in the pedestal. For the hose reel to operate correctly, these parts must be aligned correctly.

NOTE: HN models do not have a guide arm.

Guide Arm and related parts are not included.

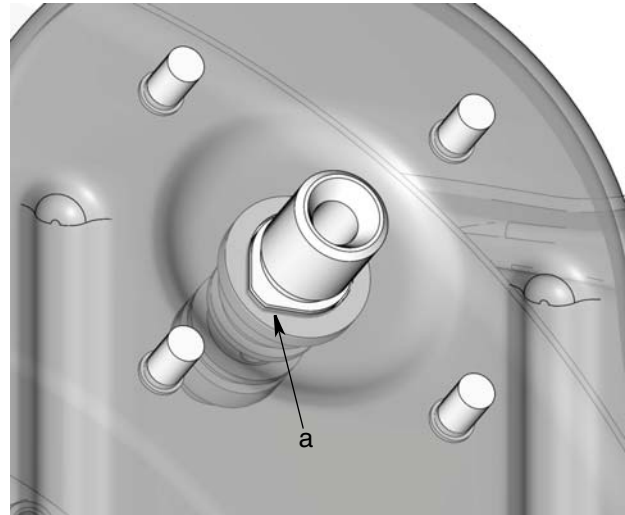

FIG. 18

19. Install large nut (11) (FIG. 16, page 21). Tighten and torque nut to 85-105 ft. lbs (378 - 467 N.m).
20. Tighten bolt (18).
21. Align guide arm (29) and guide arm (30). Install screws (27). Tighten and torque screws to 20-30 ft. lbs (89 - 133 N.m).
22. Align pedestal assembly (26) to base (24). Install 2 screws (27). Tighten and torque screws to 20-30 ft. lbs (89 - 133 N.m).
23. Re-install reel to ceiling or wall.
24. Install hose on spool following the Hose Installation instructions, page 17.
25. Flush hose following flushing instructions starting with Step 10, page 18.
26. Set spring tension following Increasing and Decreasing Spring Tension instructions on page 19.

Replacing the Service Hose



1. **Relieve the pressure.**
2. Fully extend the hose (B) and latch the reel.
3. Attach a C-Clamp (A) to the reel flange to help prevent the reel from unintentionally becoming unlatched and spinning freely (FIG. 19).

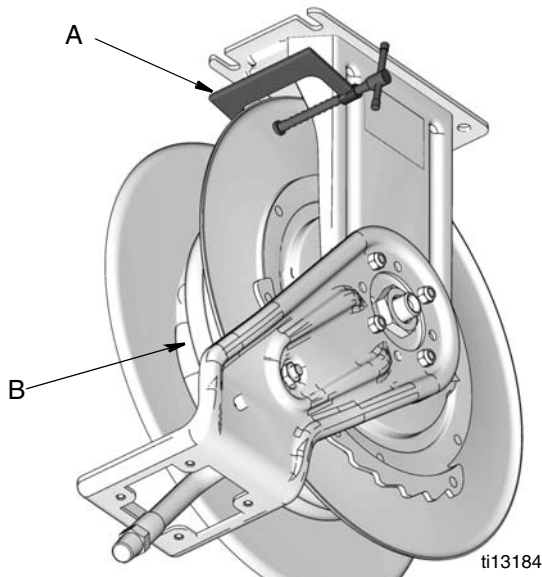
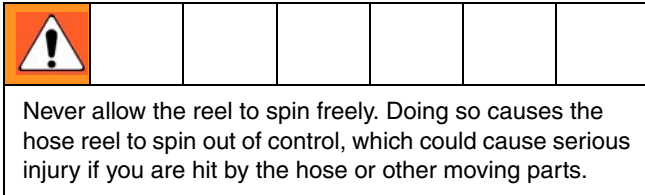

FIG. 19

4. Remove hose stop from hose end and put all the parts in a safe place to reinstall on the new hose later (FIG. 20).
 - a. Loosen and remove screws (aa) and nuts (bb).
 - b. Separate two hose stop components (cc) to remove from end of hose.

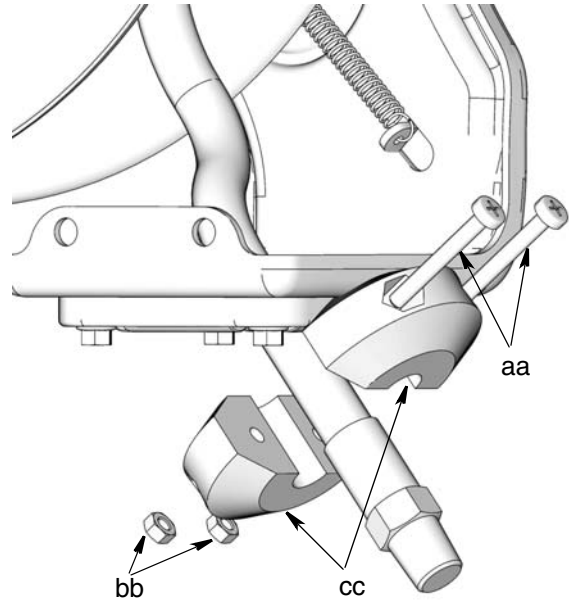
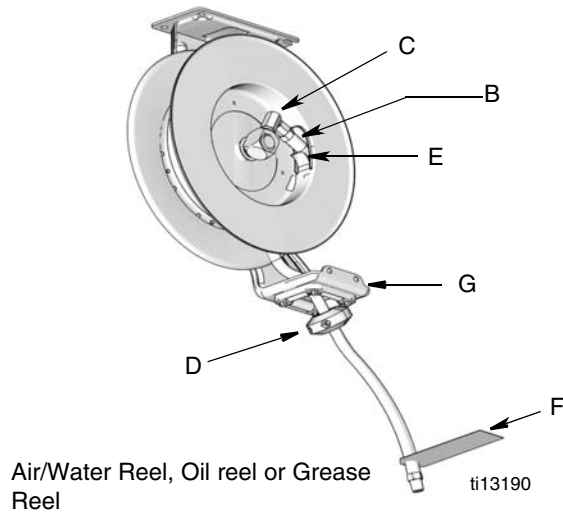

FIG. 20

5. Disconnect hose (B) from swivel (C). (Fig FIG. 21)
6. Install hose stop (D) to end of hose. If hose has a warning tag, hose stop should be installed on the same end as the warning tag (F).

NOTE: If hose is equipped with a kink guard this end must be on the same end as the hose stop.

7. Insert screws (aa) through hose stop (cc) and hand tighten nuts (bb) to hold hose stop in place.



14. Install meter or dispense valve to end of hose following instructions provided with the dispense equipment.
15. Adjust spring tension, page 18.

FIG. 21

8. Run the end of hose (B), through the hose guide (G) and then the hole (E) in reel (FIG. 21).
9. Attach hose end (B) to hose reel swivel (C). Then carefully remove C-Clamp (D) (FIG. 11).
10. Pull the hose hard (B) enough to release the latch and slowly allow the hose to retract.
11. If used, reassemble hose reel enclosure

12. Flush system.

To avoid contaminating the fluid with line-scale, chips or other installation debris, before installing meter or dispense valve to end of hose, flush the equipment with a compatible solvent such as Stoddard solvent or mineral spirits.

- a. Secure the end of the hose in a waste bucket.
 - b. Blow out entire lubricant supply line with air.
 - c. Pump solvent through line until fluid runs clear and is debris free.
 - d. Pump lubricant through line until all solvent is flushed out.
13. Re-position hose stop (D) so hose extends far enough for all operators to reach dispensing valve. Securely tighten nuts (bb) to keep hose stop in place.

Parts SD Series

Ref	Part No.	Description	Qty	Ref	Part No.	Description	Qty
5		KIT, spool (includes 5a-5j) (see page 33)	1	15V158	ARM, guide (Mercedes Blue) HPL56, HPL65, HPM65, HPM6D, HPH55, HPH5D models		
5a	◆	WASHER, 26 mm (all HPL and HPM models)	1	15V159	ARM, guide (Yellow)HPL56, HPL65, HPM65, HPM6D, HPH55, HPH5D models		
	◆	WASHER, 23 mm (all HPH models)	1				
5b	◆	RING, backup	1	15V160	ARM, guide (Red) HPL56, HPL65, HPM65, HPM6D, HPH55, HPH5D models		
5c	◆	O-RING	1	15V161	ARM, guide (White) HPL56, HPL65, HPM65, HPM6D, HPH55, HPH5D models		
5d	◆	SWIVEL, elbow	1	15V162	ARM, guide (Black) HPL56, HPL65, HPM65, HPM6D, HPH55, HPH5D models		
5e	155470	FITTING, swivel, 90°, npsm HPL3B, HPL6D, HPL33, HPL65, HPM3B, HPM6D, HPM33, HPM65 models	1	24	◆	BUSHING, pawl	1
	161037	FITTING, swivel, 90°, npsm HPL23, HPL25, HPL56 models	1	25	◆	PAWL, ratchet	1
	15Y397	FITTING, swivel, 90°, npsm HPH models	2	26	218591	KIT, roller, (includes 25a - 25d) (see page 36)	1
	125593	FITTING, swivel, 90°, bspt x bspp, HPL6D, HPL33, HPM3B, HPM6D models	1	26a	◆	BRACKET, roller	1
	125594	FITTING, swivel, 90°, 3/8 bspt x 3/8 bspp, HPH1D, HPH5D, HPH23 models	1	26b	◆	PIN, roller	4
	125595	FITTING, swivel, 90°, bspt x bspp, HPL2D, HPL23, HPL56, models	1	26c	◆	ROLLER, hose	4
5f	186579	NUT, hex, 3/8" x 18 npsm HPH models)		26d	◆	SCREW, M6 x 1.0 x 20	4
	186580	NUT, hex, 1/2" - 14 npsm HPL and HPM models	1	30		KIT, stop, hose (see page 37)	1
	16J893	NUT, hex, 1/2"-14 bspp, HPL2D, HPL6D, HPL23, HPL56, HPL33, HPM3B, HPM6D models	1				
	16J894	NUT, hex, 3/8"-19 bspp. HPH1D, HPH5D, HPH23 models	1				
5g	◆	SPOOL	1				
5h	◆	WASHER, 30 mm	1				
13	◆	NUT, lock, M8 x 1.25	4				
15	◆	SPRING, ratchet, pawl	1				
16	◆	BASE	1				
17	◆	BOLT, M10 x 1.50 x 25	1				
18	15V139	ARM, guide (Metallic Blue) HPL23, HPL25, HPL33, HPM33, HPM3B, HPH15, HPH1D, HPH23 models					
	15V140	ARM, guide (Mercedes Blue) HPL23, HPL25, HPL33, HPM33, HPM3B, HPH15, HPH1D, HPH23 models					
	15V141	ARM, guide (Yellow) HPL23, HPL25, HPL33, HPM33, HPM3B, HPH15, HPH1D, HPH23 models					
	15V142	ARM, guide (Red) HPL23, HPL25, HPL33, HPM33, HPM3B, HPH15, HPH1D, HPH23 models					
	15V143	ARM, guide (White) HPL23, HPL25, HPL33, HPM33, HPM3B, HPH15, HPH1D, HPH23 models					
	15V144	ARM, guide (Black) HPL23, HPL25, HPL33, HPM33, HPM3B, HPH15, HPH1D, HPH23 models					
	15V157	ARM, guide (Metallic Blue) HPL56, HPL65, HPM65, HPM6D, HPH55, HPH5D models					

Ref	Part No.	Description	Qty	Ref	Part No.	Description	Qty
33	109158	HOSE, 50 ft, npt (Models- HPH15A, HPH15B, HPH15C, HPH15D, HPH15E, HPH15F)	1	24J811	HOSE, 50 ft, bspt (Models- HPH55P, HPH55R, HPH55S, HPH55T, HPH55U)	1	
	124461	HOSE, 50 ft, npt (Models- HPH55A, HPH55B, HPH55C, HPH55D, HPH55E, HPH55F)	1	24K199	HOSE, 65 ft, bspp (Models- HPL56J, HPL56K, HPL56L, HPL56M, HPL56N)	1	
	253848	HOSE, 35 ft, npt (Models- HPL23A, HPL23B, HPL23C, HPL23D, HPL23E, HPL23F)	1	24K200	HOSE, 65 ft, bspt (Models- HPL56P, HPL56R, HPL56S, HPL56T, HPL56U)	1	
	253849	HOSE, 50 ft, npt (Models- HPL25A, HPL25B, HPL25C, HPL25D, HPL25E, HPL25F)	1	24K193	HOSE, 50 ft, bspp (Models- HPL65J, HPL65K, HPL65L, HPL65M, HPL65N)	1	
	253850	HOSE, 65 ft, npt (Models- HPL56A, HPL56B, HPL56C, HPL56D, HPL56E, HPL56F)	1	24K194	HOSE, 50 ft, bspt (Models- HPL65P, HPL65R, HPL65S, HPL65T, HPL65U)	1	
	253852	HOSE, 35 ft, npt (Models- HPL33A, HPL33B, HPL33C, HPL33D, HPL33E, HPL33F)	1	24J798	HOSE, 50 ft, bspp (Models- HPM65J, HPM65K, HPM65L, HPM65M, HPM65N)	1	
	253853	HOSE, 50 ft, npt (Models- HPL65A, HPL65B, HPL65C, HPL65D, HPL65E, HPL65F)	1	24J799	HOSE, 50 ft, bspt (Models- HPM65P, HPM65R, HPM65S, HPM65T, HPM65U)	1	
	253857	HOSE, 35 ft, npt (Models- HPM33A, HPM33B, HPM33C, HPM33D, HPM33E, HPM33F)	1	34▲	15W036 LABEL, warning	1	
	256864	HOSE, 50 ft, npt (Models- HPM65A, HPM65B, HPM65C, HPM65D, HPM65E, HPM65F)	1	▲ Replacement Danger and Warning labels, tags and cards are available at no cost.			
	124470	HOSE, 35 ft, npt (Models- HPH23A, HPH23B, HPH23C, HPH23D, HPH23E, HPH23F)	1	◆ Provided for reference only. Replacement part is not available.			
	24J794	HOSE, 50 ft, bspp (Models- HPH15J, HPH15K, HPH15L, HPH15M, HPH15N)	1	A complete list of all available kits begins on page 33.			
	24J795	HOSE, 50 ft, bspt (Models- HPH15P, HPH15R, HPH15S, HPH15T, HPH15U)	1				
	24J812	HOSE, 35 ft, bspp (Models- HPH23J, HPH23K, HPH23L, HPH23M, HPH23N)s	1				
	24J813	HOSE, 35 ft, bspt (Models- HPH23P, HPH23R, HPH23S, HPH23T, HPH23U)	1				
	24K195	HOSE, 35 ft, bspp (Models- HPL23J, HPL23K, HPL23L, HPL23M, HPL23N)	1				
	24K196	HOSE, 35 ft, bspt (Models- HPL23P, HPL23R, HPL23S, HPL23T, HPL23U)	1				
	24K197	HOSE, 50 ft, bspp (Models- HPL25J, HPL25K, HPL25L, HPL25M, HPL25N)	1				
	24K198	HOSE, 50 ft, bspt (Models- HPL25P, HPL25R, HPL25S, HPL25T, HPL25U)	1				
	24K191	HOSE, 35 ft, bspp (Models- HPL33J, HPL33K, HPL33L, HPL33M, HPL33N)	1				
	24K192	HOSE, 35 ft, bspt (Models- HPL33P, HPL33R, HPL33S, HPL33T, HPL33U)	1				
	24J796	HOSE, 35 ft, bspp (Models- HPM33J, HPM33K, HPM33L, HPM33M, HPM33N)	1				
	24K797	HOSE, 35 ft, bspt (Models- HPM33P, HPM33R, HPM33S, HPM33T, HPM33U)	1				
	24J810	HOSE, 50 ft, bspp (Models- HPH55J, HPH55K, HPH55L, HPH55M, HPH55N)	1				

**HPH, HPP, HPL, HPM Models
Air/Water Reel, Oil Reel or
Grease Reel**

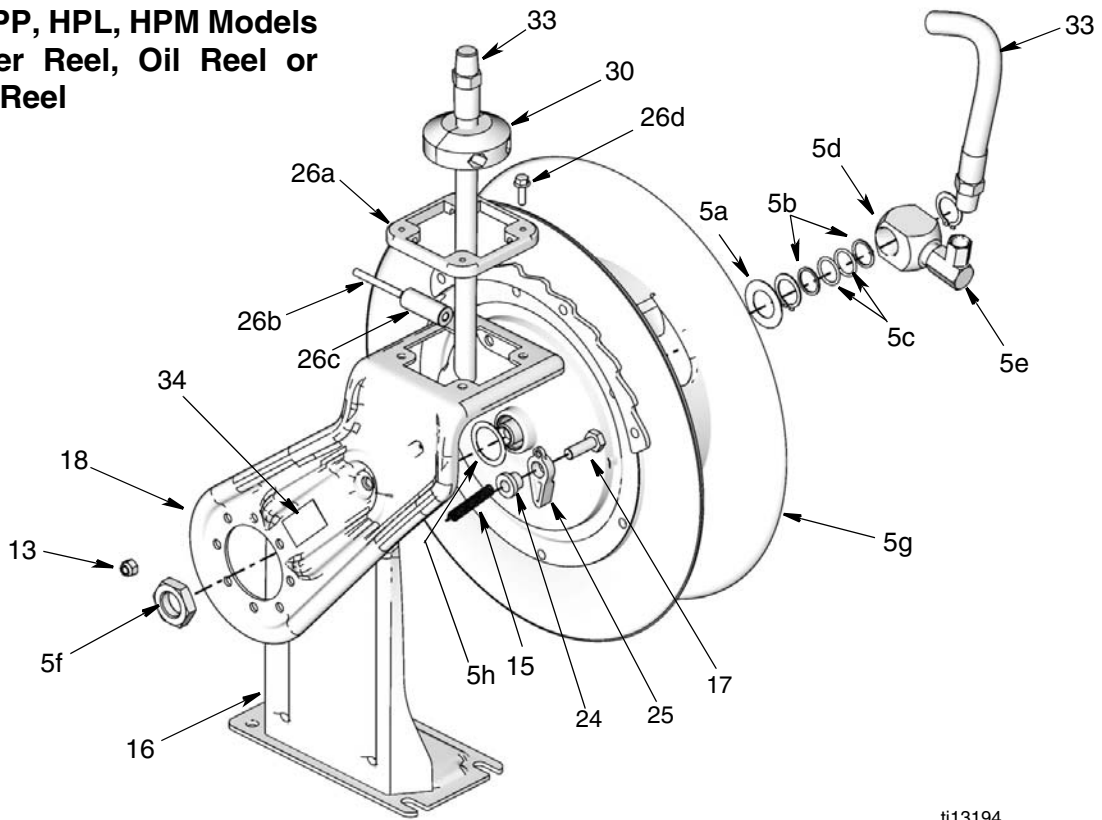

ti13194

ti13194-2

Parts XD Series; HS Models

Ref	Part No.	Description	Qty	Ref	Part No.	Description	Qty
5		KIT, spool (see page 33) (includes parts 5a-5j)	1	253853	HOSE, 50 ft, npt (models HSL65A, HSL65B, HNL65F, HNL65A, HNL65B, HNL65F)	1	
5e	◆	RING, retaining	1	253857	HOSE, 35 ft, npt (models (HSM33A, HSM33B, HSM33F)	1	
5h	◆	SPOOL	1	256864	HOSE, 50 feet, npt (models HSM65A, HSM65B, HNM65F, HNM65A, HNM65B, HNM65F)	1	
5j	◆	WASHER, 30 mm	1	24J794	HOSE, 50 ft, bspp (models HSH15J, HSH15K, HSH15N)	1	
5k	◆	WASHER, square center	1	24J795	HOSE, 50 ft, bspt (models HSH15U, HSH15P, HSH15R)	1	
6	◆	RING, backup	2	24J810	HOSE, 50 ft, bspp (models HSH55J, HSH55K, HSH55N)	1	
7	◆	O-RING	2	24J811	HOSE, 50 ft, bspt (models HSH55P, HSH55R, HSH55U)	1	
8	◆	SWIVEL, elbow	1	24K193	HOSE, 50 ft, bspp (models HSL65J, HSH65K, HSH65N)	1	
9	◆	WASHER	1	24K194	HOSE, 50 ft, bspt (models HSL65P, HSL65R, HSL65U)	1	
10	155470	FITTING, swivel, 90° npsm HSL33, HSM33, HSM3B, HSL65, HSL6D, HSM65, HSM6D, HNL65, HNM65 models	1	24K197	HOSE, 50 ft, bspp (models HSL25J, HSL25K, HSL25N)	1	
	15Y397	FITTING, swivel, 90° npsm HSH, HNH55 models	1	24K198	HOSE, 50 ft, bspt (models HSL25P, HSL25R, HSL25U)	1	
	161037	FITTING, swivel, 90° npsm HSL25, HSL2D, HSL56, HSL5D, HNL56 models	1	24K191	HOSE, 35 ft, bspp (models HSL33J, HSL33K, HSL33N)	1	
	125593	FITTING, swivel, 90°, bspt x bspp, HSL56, HSL65, HSL6D, HSM33, HSM3B, HSM65, HSM6D models	1	24K192	HOSE, 35 ft, bspt (models HSL33P, HSL33R, HSL33U)	1	
	125594	FITTING, swivel, 90° 3/8 bspt x 3/8 bspp, HSH models	1	24K796	HOSE, 35 ft, bspp (models HSM33J, HSM33K, HSM33N)	1	
	125595	FITTING, swivel, 90°, bspt x bspp, HSL25, HSL2D, HSL33 models	1	24K797	HOSE, 35 ft, bspt (models HSM33P, HSM33R, HSM33U)	1	
11	186579	NUT, hex 3/8" - 18 npsm, models HSH15, HSH1D, HSH55, HSH55B, HNH55	1	24K199	HOSE, 65 ft, bspp (models HSL56 J, HSL56K, HSL56N)	1	
	186580	NUT, hex, 1/2" - 14 npsm, HNL56, HNL65, HSL25, HSL33, HSL56, HSL65, HSL2D, HSL6D, HSM3B, HSM6D, HSM33, HSM65, models	1	24K200	HOSE, 65 ft, bspt (models HSL56P, HSL56R, HSL56U)	1	
	16J893	NUT, hex, 1/2-14 bspp, HSL25,HSL2D, HSL33, HSL56, HSL65, HSL6D, HSM33, HSM3B, HSM65, HSM6D	1	24J798	HOSE, 50 ft, bspp (models HSM65J, HSM65K, HSM65N)	1	
	16J894	NUT, hex, 3/8-19 bspp, HSH15, HSH1D, HSH55, HSH5D models	1	24J799	HOSE, 50 ft, bspt (models HSM65P, HSM65R, HSM65U)	1	
14	◆	ADJUSTER, power spring	1	29	15V145	ARM, guide, dual (Metallic Blue) HSL25, HSL33, HSM33, HSH15,HSH1D,HSM3B models (not included on HN models)	
17	◆	WASHER, 8 mm	1	15V146	ARM, guide, dual (White) HSL25, HSL33, HSM33, HSH15,HSH1D,HSM3B models (not included on HN models)		
18	◆	SCREW, M8 x 1.25 x 120	1	15X939	ARM, guide, dual (Yellow) HSL25, HSL33, HSM33, HSH15,HSH1D,HSM3B models (not included on HN models)		
19	◆	SCREW, M5 x .80 x 20	2	15Z003	ARM, guide, dual (Desert Sand) HSL25, HSL33, HSM33, HSH15,HSH1D,HSM3B models (not included on HN models)		
24	◆	BASE, dual	1				
25	◆	SHAFT, swivel	1				
26	◆	PEDESAL	1				
27	◆	SCREW, M8 X 1.25 x 20	4				
28	109158	HOSE, 50 feet, npt (models HSH15A, HSH15B)	1				
	124461	HOSE, 50 feet, npt (models HSH55A, HSH55B, HNH55f, HNH55A, HNH55B, HNH55F)	1				
	253849	HOSE, 50 ft, npt (models HSL25A, HSL25B, HSL25F)	1				
	253850	HOSE, 65 ft, npt (models HSL56A, HSL56B, HNL56F, HNL56A, HNL56B, HNL56F)	1				

Ref	Part No.	Description	Qty	Ref	Part No.	Description	Qty
	15V163	ARM, guide, dual (Metallic Blue) HSL56, HSL65, HSM65, HSH55, HSH5D, HSM6D models (not included on HN models)			16A124	ARM, guide (Desert Sand) HSHC5, HSHFF, HSLC8, HSLD5, HSLE3, HSMC8, HSMD5, HSMDD, HSPB8, HSHCD, HSMCF, HSDD5, HSDDD models (not included on HN models)	
	15V164	ARM, guide, dual (White) HSL56, HSL65, HSM65, HSH55, HSH5D, HSM6D models (not included on HN models)		32		NUT, lock, M8 x 1.25	8
	15X942	ARM, guide, dual (Yellow) HSL56, HSL65, HSM65, HSH55, HSH5D, HSM6D models (not included on HN models)		33	218591	KIT, roller (includes 33a-33d) (page 36) (not included on HN models)	
	15Z007	ARM, guide, dual (Desert Sand) HSL56, HSL65, HSM65, HSH55, HSH5D, HSM6D models (not included on HN models)		33a	◆	BRACKET, roller	1
				33b	◆	PIN, roller	4
				33c	◆	ROLLER, hose	4
				33d	◆	SCREW, M6 x 1.0 x 20	4
				34▲	15W036	LABEL, warning	1
				37	◆	BUSHING, pawl	1
				38	◆	PAWL, ratchet	1
				39	◆	BOLT, M10 x 1.5 x 25 lg	1
				40	◆	SPRING, ratchet pawl	1
				48		KIT, stop, hose (page 37)	1
				▲ Replacement Danger and Warning labels, tags and cards are available at no cost.			
				◆ Provided for reference only. Replacement part is not available.			
				A complete list of all available kits begins on page 33.			
30	15V143	ARM, guide (White) HSL25, HSL33, HSM33, HSH15, HSH1D, HSM3B models (not included on HN models)	1				
	15V139	ARM, guide (Metallic Blue) HSL25, HSL33, HSM33, HSH15, HSH1D, HSM3B models (not included on HN models)					
	15V141	ARM, guide (Yellow) HSL25, HSL33, HSM33, HSH15, HSH1D, HSM3B models (not included on HN models)					
	15Z004	ARM, guide (Desert Sand) HSL25, HSL33, HSM33, HSH15, HSH1D, HSM3B models (not included on HN models)					
	15V161	ARM, guide (White) HSL56, HSL65, HSM65, HSH55, HSH5D, HSM6D models (not included on HN models)					
	15V157	ARM, guide (Metallic Blue) HSL56, HSL65, HSM65, HSH55, HSH5D, HSM6D models (not included on HN models)					
	15V159	ARM, guide (Yellow) HSL56, HSL65, HSM65, HSH55, HSH5D, HSM6D models (not included on HN models)					
	15Z008	ARM, guide (Desert Sand) HSL56, HSL65, HSM65, HSH55, HSH5D, HSM6D models (not included on HN models)					
	16A121	ARM, guide (White) HSHC5, HSHFF, HSLC8, HSLD5, HSLE3, HSMC8, HSMD5, HSMDD, HSPB8, HSHCD, HSMCF, HSDD5, HSDDD models					
	16A122	ARM, guide (Metallic Blue) HSHC5, HSHFF, HSLC8, HSLD5, HSLE3, HSMC8, HSMD5, HSMDD, HSPB8, HSHCD, HSMCF, HSDD5, HSDDD models (not included on HN models)					
	16A123	ARM, guide (Yellow) HSHC5, HSHFF, HSLC8, HSLD5, HSLE3, HSMC8, HSMD5, HSMDD, HSPB8, HSHCD, HSMCF, HSDD5, HSDDD models (not included on HN models)					

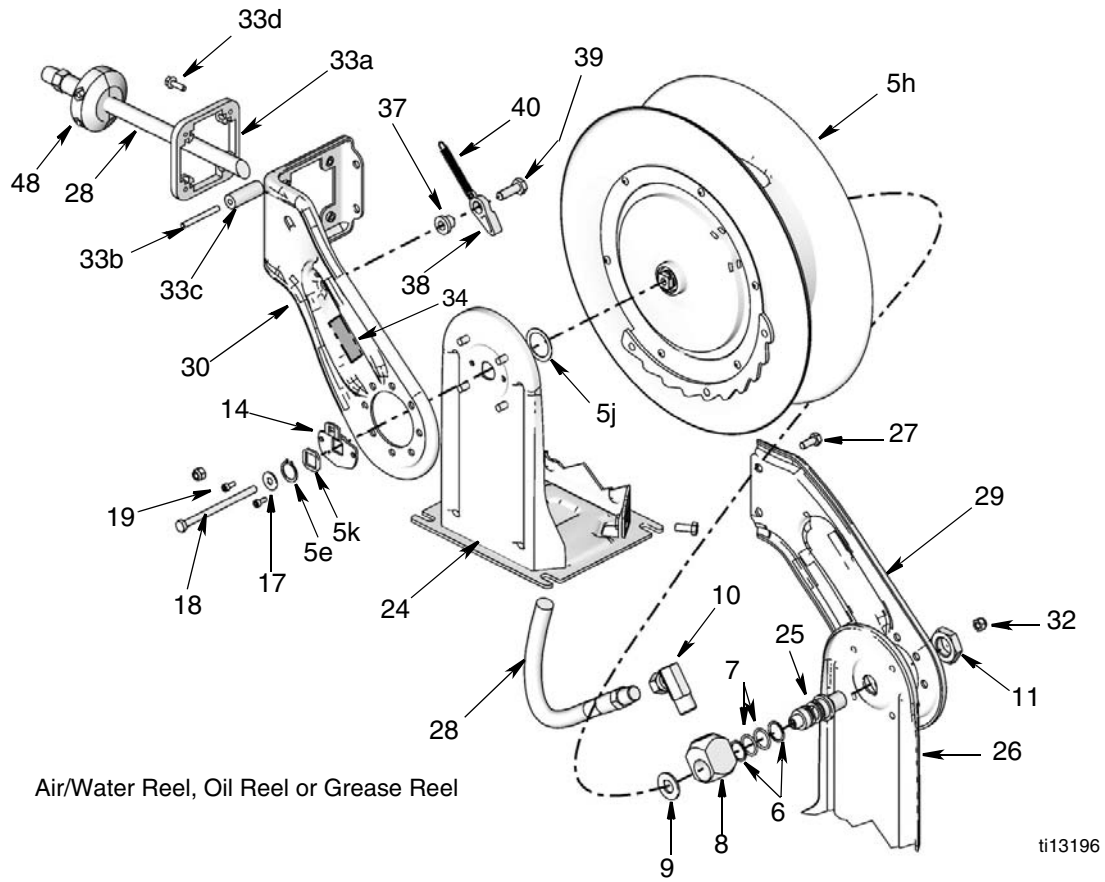

Parts XD Series; HN Models

Ref	Part No.	Description	Qty
5		KIT, spool (see page 33) (includes parts 5a-5j)	1
5e	◆	RING, retaining	1
5h	◆	SPOOL	1
5j	◆	WASHER, 30 mm	1
5k	◆	WASHER, square center	1
6	◆	RING, backup	2
7	◆	O-RING	2
8	◆	SWIVEL, elbow	1
9	◆	WASHER	1
10	155470	FITTING, swivel, 90° (all HNL65 and HNM65 models)	
	15Y397	FITTING, swivel, 90° (all HNH55 models)	
	161037	FITTING, swivel, 90° (all HNL56 models)	1
11	186579	NUT, hex 3/8" - 18 npsm (models HNH55)	1
	186580	NUT, hex, 1/2" - 14 npsm (all models except: HNH55)	1
14	◆	ADJUSTER, power spring	1
17	◆	WASHER, 8 mm	1
18	◆	SCREW, M8 x 1.25 x 120	1
19	◆	SCREW, M5 x .80 x 20	2
24	◆	BASE, dual	1
25	◆	SHAFT, swivel	1
26	◆	PEDESAL	1
27	◆	SCREW, M8 X 1.25 x 20	4
28	124461	HOSE, 50 feet, (model HNH55)	1
	253850	HOSE, 65 ft (model HNL56)	1
	253853	HOSE, 50 ft (model HNL65)	1
	256864	HOSE, coupled, 50 feet (mode HNM65)	1
32		NUT, lock, M8 x 1.25	8
34▲	15W036	LABEL, warning	1
37	◆	BUSHING, pawl	1
38	◆	PAWL, ratchet	1
39	◆	BOLT, M10 x 1.5 x 25 lg	1
40	◆	SPRING, ratchet pawl	1
48		KIT, stop, hose (page 37)	1

▲ Replacement Danger and Warning labels, tags and cards are available at no cost.

◆ Provided for reference only. Replacement part is not available.

A complete list of all available kits begins on page 33.

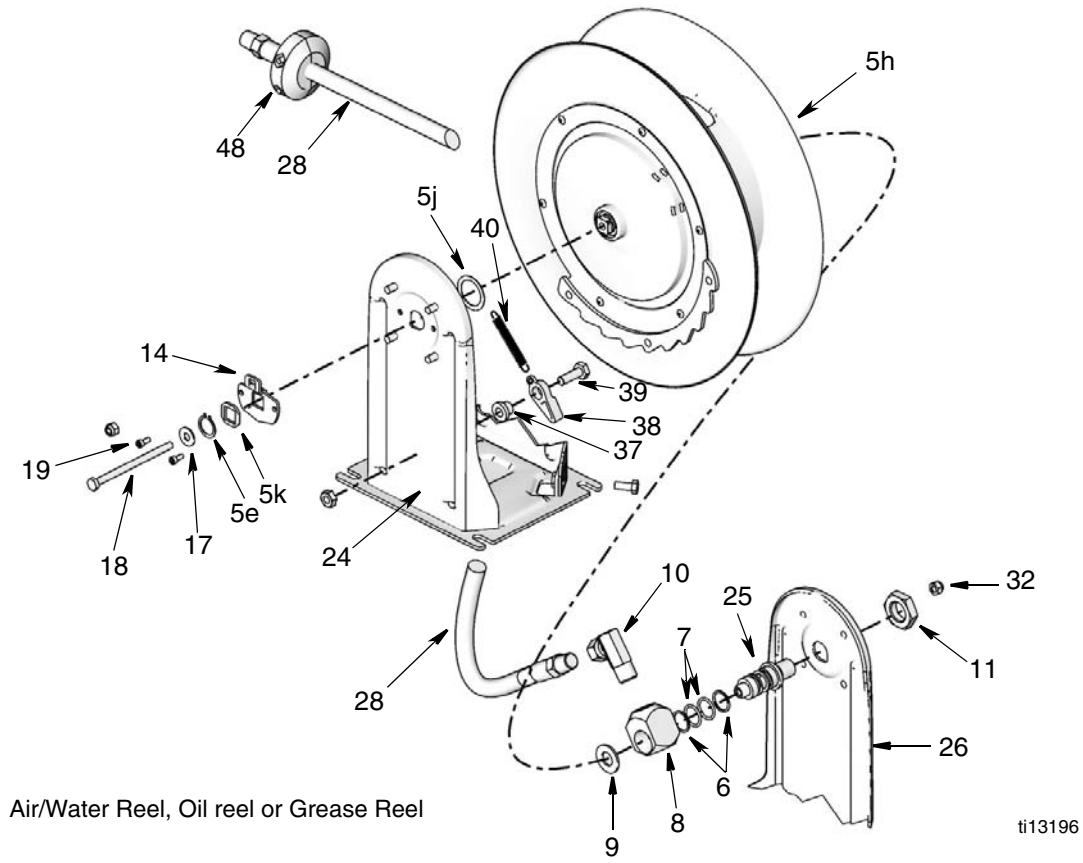

Kits

Spool Assembly Kits

Part No.	Model.	NPT/BSP Models	Size	Media	Line Size (inches)	Length (feet)
15Y486	HPL2D# HPL25#	NPT	10	Air/Water	3/8	50
24K432	HPL2D#	BSP	10	Air/Water	3/8	50
15Y487	HPL6D# HPL65# HPL6H#	NPT	20	Air/Water	1/2	50
24K433	HPL6D#	BSP	20	Air/Water	1/2	50
15Y488 24L864	HPL23#	NPT BSP	10	Air/Water	3/8	35
15Y489 24L865	HPL56# HPL5J#	NPT BSP	20	Air/Water	3/8	65
15Y490 24L866	HPL33#	NPT BSP	10	Air/Water	1/2	35
15Y491	HPM3B# HPM33#	NPT	10	Oil	1/2	35
24K434	HPM3B#	BSP	10	Oil	1/2	35
15Y492	HPM6D# HPM65# HPM6H#	NPT	20	Oil	1/2	50
24K435	HPM6D#	BSP	20	Oil	1/2	50
15Y493	HPH1D# HPH15#	NPT	10	Grease	1/4	50
24K436	HPH1D#	BSP	10	Grease	1/4	50
15Y494	HPH5D# HPH55# HPH5H#	NPT	20	Grease	3/8	50
24K437	HPH5D#	BSP	20	Grease	3/8	50
15Y495 24L867	HPH23#	NPT BSP	10	Grease	3/8	35
15Y496‡	HSL2D# HSL25#	NPT BSP	10	Air/Water	3/8	50
15Y497‡	HSL6D# HSL65# HNL56#	NPT BSP	20	Air/Water	1/2	50
15Y498‡	HSL56# HNL65#	NPT	20	Air/Water	3/8	65

Part No.	Model.	NPT/BSP Models	Size	Media	Line Size (inches)	Length (feet)
15Y499‡	HSL33# HSM3B# HSM33#	NPT BSP	10	Air/Water / Oil	1/2	35
15Y500‡	HSM6D# HSM65# HNM65#	NPT BSP	20	Oil	1/2	50
15Y501‡	HSH15# HSH1D#	NPT BSP	10	Grease	1/4	50
15Y502‡	HSH5D# HSH55# HSH55#	NPT BSP	20	Grease	3/8	50

‡ Kit does not include swivel. Order swivel kit separately. See page 34 for complete list of swivel kits.

Swivel Kits: 15Y480 and 24M580, 15Y481 and 24M579

(Instruction Manual: 313432)

Low and Medium Pressure Reels: 15Y480 and 24M579

Description	Qty
SCREW M8 x 1.25 x 20	4
SCREW, M8 x 1.25 x 120	1
WASHER, 8 mm	1
WASHER, 16 mm	1
SHAFT, swivel, MP	1
ELBOW, swivel, 1/2"	1
RING, backup	2
O-RING	2
RING, retaining	1
NUT, 1/2" npsm	1
ELBOW, male x female, 1/2" x 3/8"	1
ELBOW, male x female, 1/2" x 1/2"	1
NUT, M8 x 1.25	4

High Pressure Reels: 15Y481 and 24M580

Description	Qty
SCREW M8 x 1.25 x 20	4
SCREW, M8 x 1.25 x 120	1
WASHER, 8 mm	1
WASHER, 16 mm	1
SHAFT, swivel	1
ELBOW, swivel, 3/8"	1
RING, backup	2
O-RING	2
WASHER, thrust, 23 mm	1
RING, retaining	1
NUT, 3/8" npsm	1
ELBOW, male x female, 3/8" x 3/8"	1
NUT, M8 x 1.25	4

Label, Fluid Identification: 24A223

ANTI-FREEZE	HYDRAULIC
SAE 10W-40	ATF
SAE 10W-30	DEXRON
SAE 5W-40	SYNTHETIC
SAE 10W	SAE 5W-30
SAE 20W	SAE 5W-40
SAE 30W	AIR

BSPP Hose Seal Kit: 24M713

Description	Qty.
SEAL, elastomeric, 1/4-19	1
SEAL, elastomeric, 3/8-19	1
SEAL, elastomeric, 1/2-14	1
SEAL, elastomeric, 1"- 19	1

Swivel Seal Kits: 24A952, 24A953

(Instruction Manual: 313432)

24A952 Used with Low and Medium Pressure Reels

Description	Qty
WASHER, 8 mm	1
NUT, M8 x 1.25	4
RING, retaining	1
RING, backup	2
WASHER, 16 mm	1
O-RING	2
SCREW, M8 x 1.25 x 120	1
SCREW, M8 x 1.25 x 20	4

24A953 Used with High Pressure Reels

Description	Qty
WASHER, 8 mm	1
NUT, M8 x 1.25	4
O-RING	2
RING, retaining	1
RING, backup	2
WASHER, 23 mm	1
WASHER, 16 mm	1
SCREW, M8 x 1.25 x 120	1
SCREW, M8 x 1.25 x 20	4

Latch Kit: 15Y503

(Instruction Manual: 406801)

Description	Qty
SCREW, M8 x 1.25 x 20	2
PAWL, ratchet	1
SPRING, ratchet, pawl	1
SCREW, M10 x 1.50 x 25	1
BUSHING	1
NUT, M8 x 1.25	4
SCREW, M8 x 1.50 x 40	1
NUT, M10 x 1.50	1

Enclosure Retrofit Kit: 24C100

(Instruction Manual: 313902)

Description	Qty
ARM, hose guide	1
BASE, reel, enclosed	1
NUT, lock	4
SCREW	4
WASHER, flat	3
BOLT, m10 x 40lg	1
NUT, hex	1
WASHER, lock, spring	1
NUT, lock	4
SCREW	4
NUT, hex	5
WASHER, lock	1
SCREW, shoulder, #10	1

Hose Inlet Kit: 224417, 218550, 218549

(Instruction Manual 406741)

1/4" NPT Inlet: 224417

Description	Qty
HOSE, coupled, 24"	1
FITTING, union, adapter, 90°	1

1/4" BSPT Inlet: 24C442

Description	Qty
HOSE, 1/4" ID x 3 ft grease	1
FITTING, 3/8" BSPP to 1/4" BSPT	1

1/4" BSPP Inlet: 24J257

Description	Qty
HOSE, 1/4" ID x 3 ft grease	1

3/8" Inlet: 218550

Description	Qty
HOSE, coupled, 24"	1
FITTING, union, adapter, 90°	1

3/8" BSPT Inlet: 24M231

Description	Qty
FITTING, swivel, 90°, 3/8" BSPP x BSPT	1
HOSE, coupled, 36", 3/8 BSPT	1

3/8" BSPP Inlet: 24M230

Description	Qty.
HOSE, 3/8" x 36", 5000 psi	1
CONNECTOR, hose, 3/8" ID x 3/8-19 BSPP	1
SEAL, elastomeric, 3/8-19 BSPP	1
FERRULE, hose, 3/8", grease	1
CONNECTOR, hose, 3/8" ID, swivel, elbow	1
TAG, hose	1

1/2" NPT Inlet: 218549

Description	Qty
HOSE, coupled, 24"	1
FITTING, swivel, union, 90°	1

1/2" BSPT Inlet: 24C441

Description	Qty
HOSE, coupled, 1/2" ID x 3 ft oil	1
FITTING, 1/2" BSPP to 1/2" BSPT	1

1/2" BSPP Inlet: 24J256

Description	Qty
HOSE, 1/2" ID x 3 ft oil	1

Mounting Adapter: 24A224 (page 10)

Description	Qty
BASE, adapter	1
SCREWS, 3/8" - 16 x 3/4"	4

Hose Guide Kits

Roller Bracket Repair: 218591

(Instruction Manual: 406743)

Description	Qty
BRACKET, hose guide	1
PIN, roller	4
ROLLER, hose	4
NUT, lock, #10 - 32	4
SCREW, #10 - 32 x 3/4"	4
SCREW, M6 x 1.0 x 20	4

Cabinet Mounting Kit: 15Y478

Description	Qty
BRACKET, hose guide	1
PIN, roller	4
ROLLER, hose	4
PLATE, mounting	1
NUT, lock, #10 - 32	4
SCREW, #10 - 32 x 3/4"	4

**Hose Reel Stop Kit: 218340,
218341, 222225**

(Instruction Manual: 406742)

1/4" and 3/8" ID Hoses: 218340

Description	Qty
NUT, hex, jam	2
SCREW, machine, phillips	2
STOP, hose, 0.656" ID	2

3/8" and 1/2" ID Hoses: 218341

Description	Qty
NUT, hex, jam	2
SCREW, machine, phillips	2
STOP, hose, 0.782" ID Kit	2

1/4" ID Hoses: 222225

Description	Qty
NUT, hex, jam	2
SCREW, machine, phillips	2
STOP, hose, 0.53" ID Kit	2

**Intermediate Hose and Fitting
Repair Kit: 24N719****Used with**

Model	Series
HSH15*	B-D
HSH55*	D-F
HPH15*	A-C
HPH23*	C-E
'HPH55*	C-E

Description	Qty.
HOSE, coupled 15 IN, 3/8" ID	1
FITTING, swivel, 90°	1

Technical Data

Low Pressure Hose Reels and Hoses

Fluid Pressure	300 psi (20.7 bar, 2.07 MPa)
Air/Water, all hose diameters	
Inlet	1/2" NPSM Male; 1/2" BSPP Male
Outlet	1/2" or 3/8" NPT Male; 1/2" or 3/8" BSPP Male; 1/2" or 3/8" BSPT Male
Operating Temperature	-20°F to 190°F (-28°C to 87°C)
Wetted parts - Bare Hose Reel Only	Zinc plated steel, anodized aluminum, Nitrile rubber
Dimensions	Page 39

Medium Pressure Hose Reels

Fluid Pressure	2000 psi (172 bar, 17.2 MPa)
Oil	
Inlet	1/2" NPSM Male; 1/2" BSPP Male
Outlet	1/2" or 3/8" NPT Male; 1/2" or 3/8" BSPP Male; 1/2" or 3/8" BSPT Male
Operating Temperature	-20°F to 190°F (-28°C to 87°C)
Wetted parts - Bare Hose Reel Only	Zinc plated steel, anodized aluminum, Nitrile rubber
Dimensions	Page 39

High Pressure Hose Reels

Fluid Pressure	5000 psi (344 bar, 34.4 MPa)
Grease, 1/4" diameter hose	4800 psi (331 bar, 33.1 MPa)
Grease, 3/8" diameter hose	
Inlet	3/8" NPSM Male; 3/8" BSPP Male
Outlet	1/4" NPT Male; 1/4" BSPP Male, 1/4" BSPT Male
Operating Temperature	-40°F to 200°F (-40°C to 93°C)
Dry Weight	HP Model (for example HPH55B): 52 lbs (23.5 kg) HS Model (for example HSH55B): 59 lbs (26.5 kg) HN Model (for example HNL56A): 52 lbs (23.5 kg)
Wetted parts - Bare Hose Reel Only	Zinc plated steel, polyurethane, steel
Dimensions	
HS Models	Page 40
HN Models	Page 41

Sound Data: All Hose Reels

Sound Pressure*	HP Model: 80 dB(A) HS Model: 78 dB(A)
Sound Power**	HP Model: 87 dB(A) HS Model: 88 dB(A)

*All readings taken at assumed retraction rate, from assumed operator position.

**Sound Power tester per ISO 9614-2.

Dimensions

HP Models

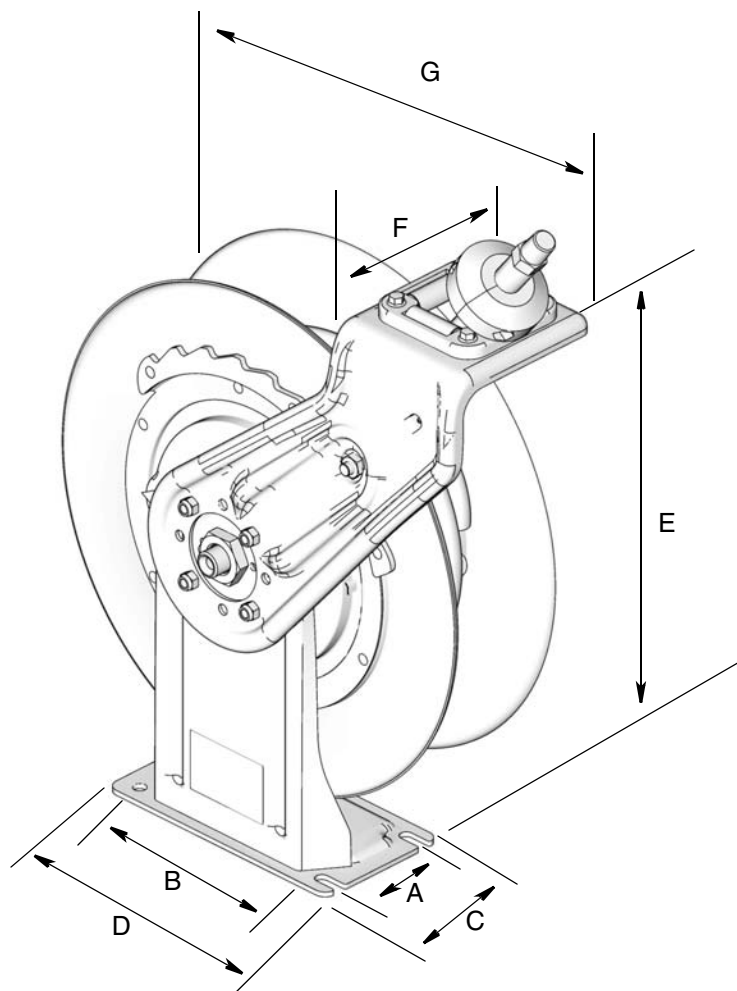

Pressure	Size	A	B	C	D	E†	F	G◆
Low	10	3.5 inches (89 mm)	7.5 inches (191 mm)	4.7 inches (120 mm)	9 inches (229 mm)	19.5 inches (498 mm)	7.0 inches (177 mm)	17.1 inches (435 mm)
Medium	10							
High	10							
Low	20	3.5 inches (89 mm)	7.5 inches (191 mm)	4.7 inches (120 mm)	9 inches (229 mm)	21.8 inches (554 mm)	7.0 inches (177 mm)	19.2 inches (487 mm)
Medium	20							
High	20							

† Measurement taken from base to top of bolts.

◆ Measurement taken from edge of spool to front of arm.

0.75 inch/
19.05 mm

HS Models

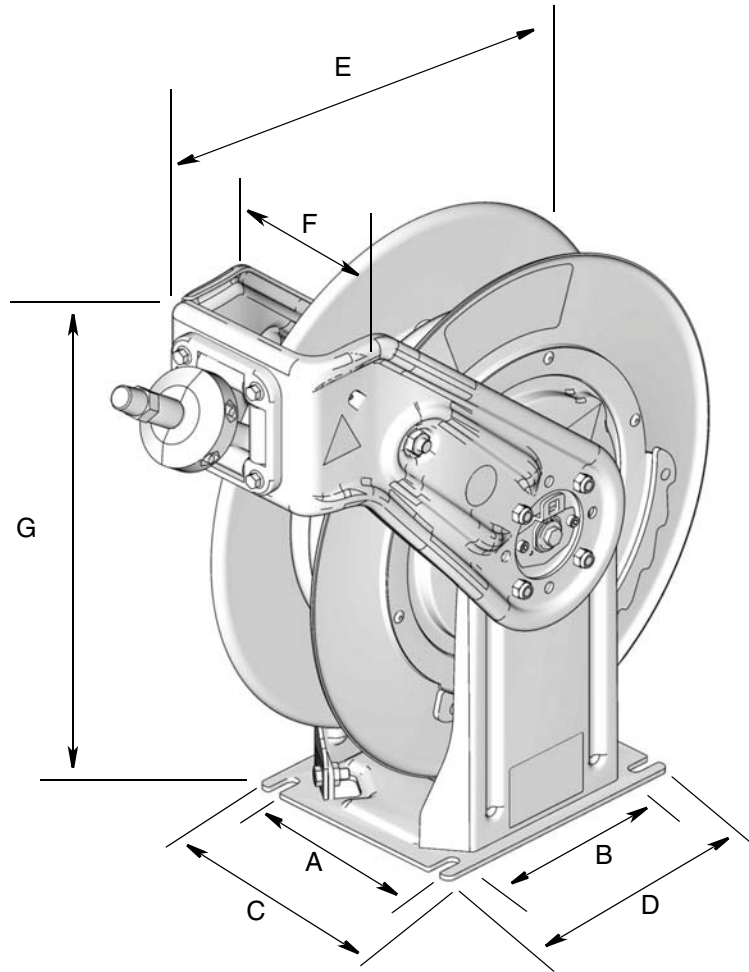

Pressure	Size	A	B	C	D	E†	F	G◆
Low	10	6.5 inches (165 mm)	7.5 inches (191 mm)	7.7 inches (196 mm)	9 inches (229 mm)	18.5 inches (473 mm)	7.5 inches (196 mm)	18 inches (460 mm)
Medium	10							
High	10							
Low	20	6.5 inches (165 mm)	7.5 inches (191 mm)	7.7 inches (196 mm)	9 inches (229 mm)	21 inches (533 mm)	7.5 inches (196 mm)	20 inches (508 mm)
Medium	20							
High	20							

† Measurement taken from base to top of bolts.

◆ Measurement taken from edge of spool to front of arm.

HN Models

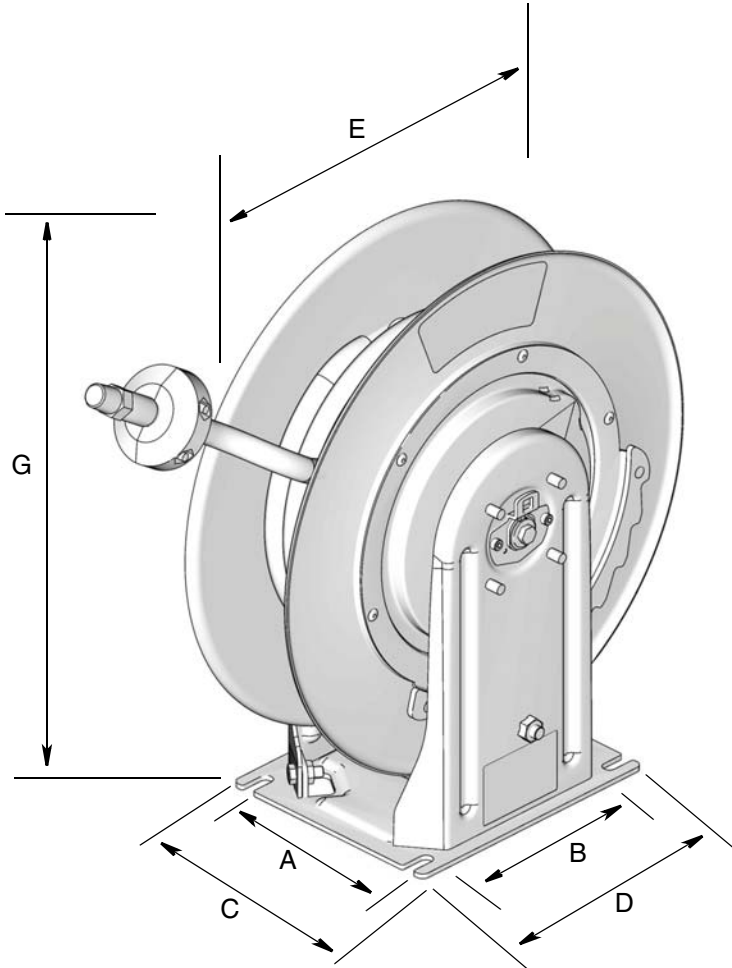

Pressure	Size	A	B	C	D	E	G
Low	10	6.5 inches (165 mm)	7.5 inches (191 mm)	7.7 inches (196 mm)	9 inches (229 mm)	18.2 inches (463 mm)	20 inches (508 mm)
Medium	10						
High	10						
Low	20	6.5 inches (165 mm)	7.5 inches (191 mm)	7.7 inches (196 mm)	9 inches (229 mm)	18.2 inches (463 mm)	20 inches (508 mm)
Medium	20						
High	20						

Mounting Channel Dimensions

(Side dimension for all kits, page 47)

1 Reel Base - Included in Kits 24A934 / 203521

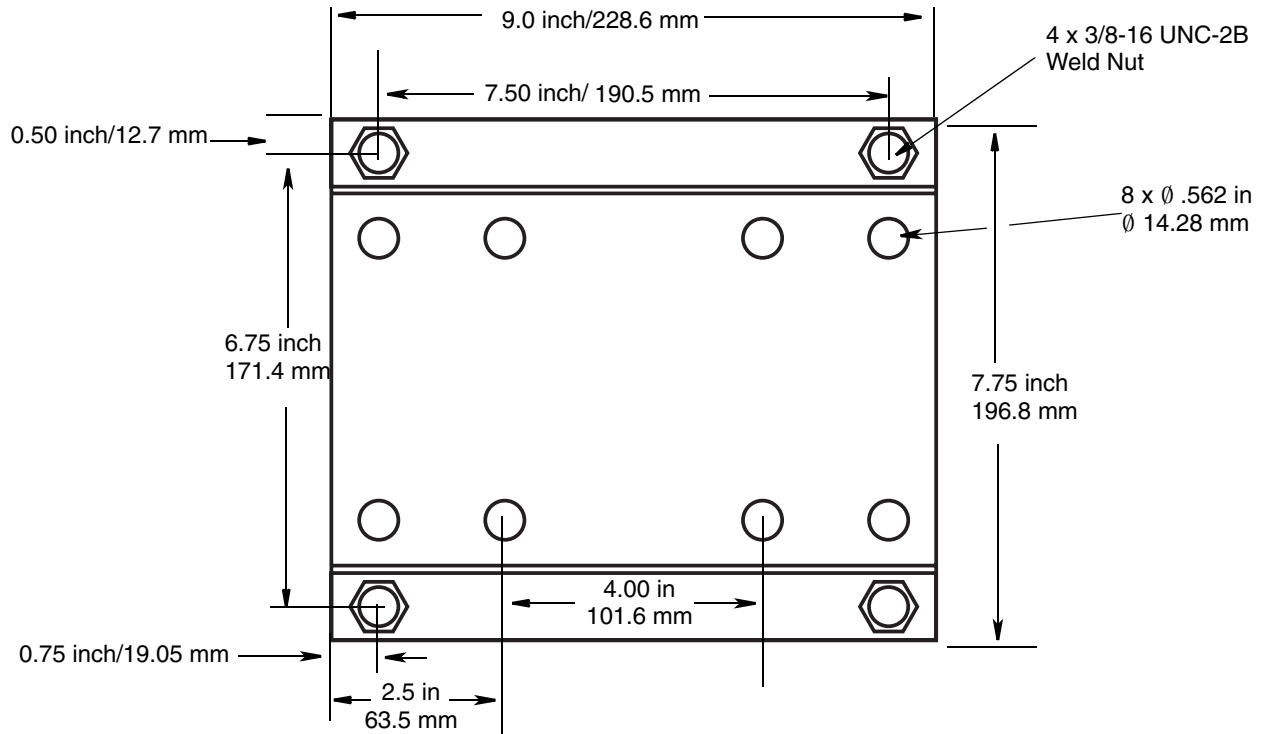

2 Reel Base - Included in Kits 24A935 / 203522

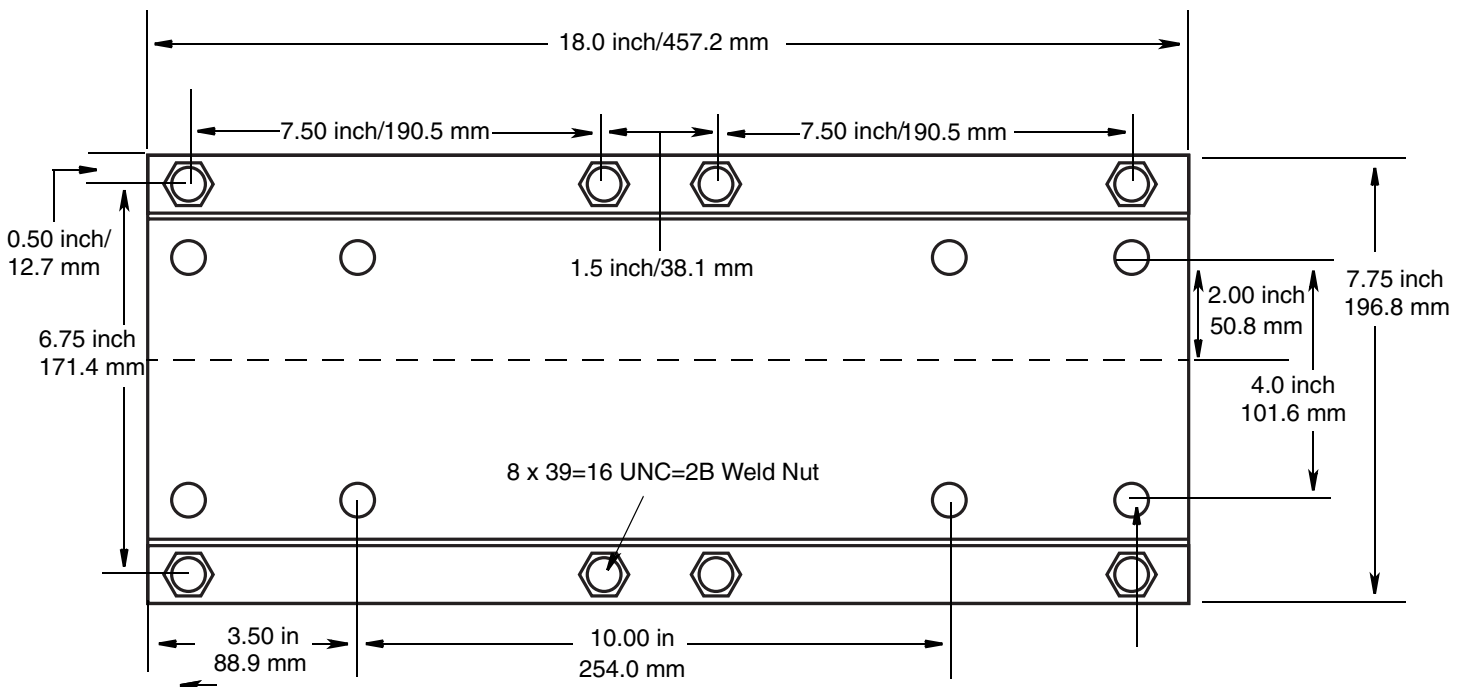

3 Reel Base Weldment

Included in Kits 24A936, 203523

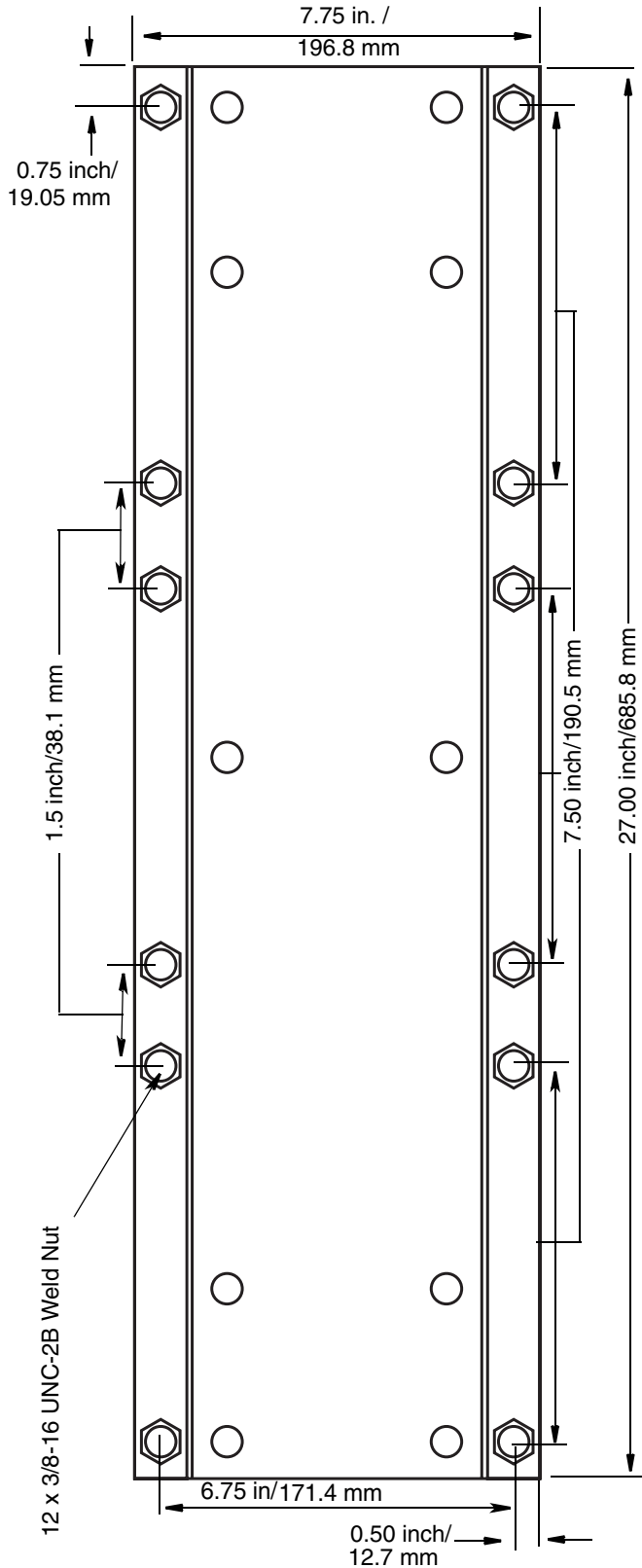

4-Reel Base Weldment

Included in Kits 24A937, 203524

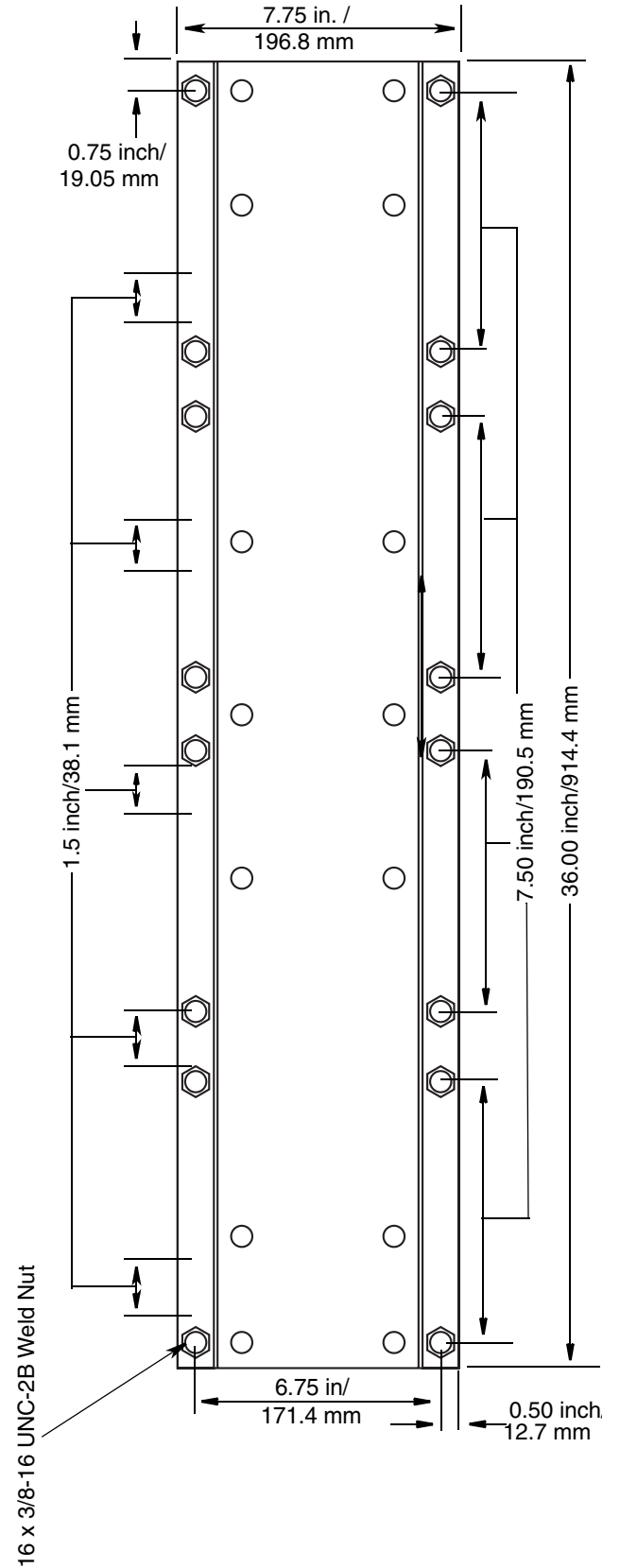

5 Reel Base Weldment

Included in Kits 24A938, 203525

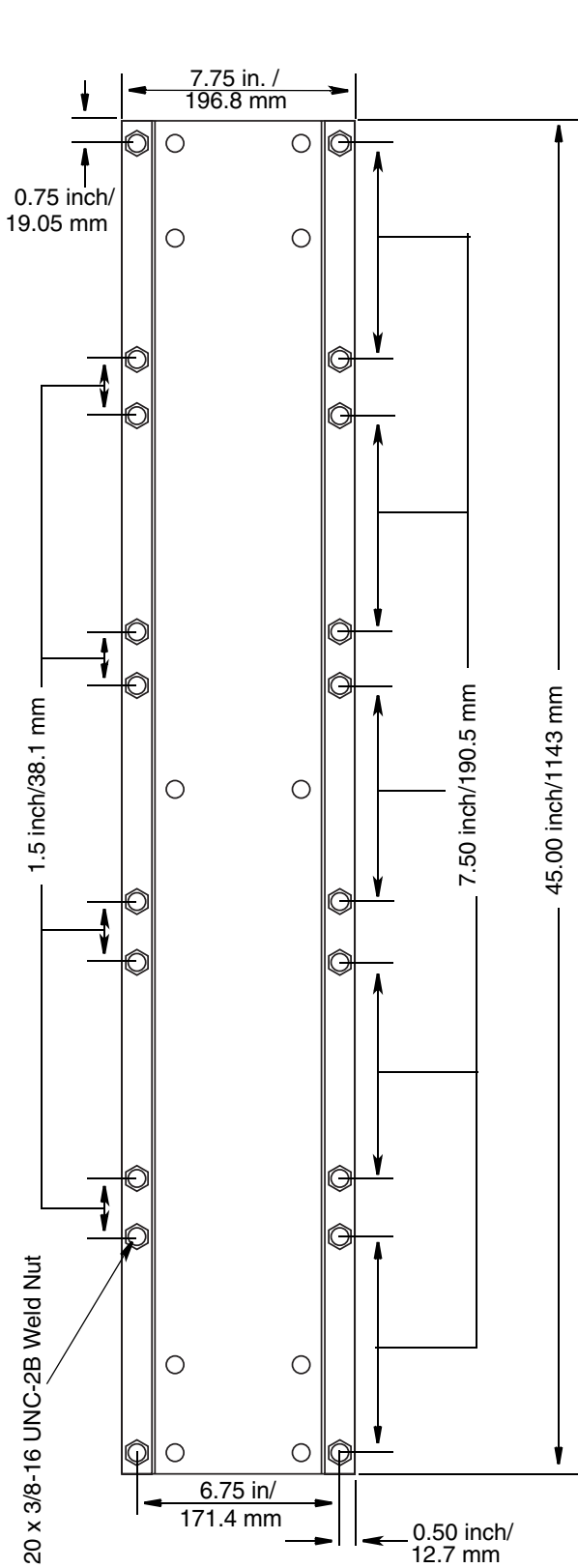

6-Reel Base Weldment

Included in Kits 24A939, 203526

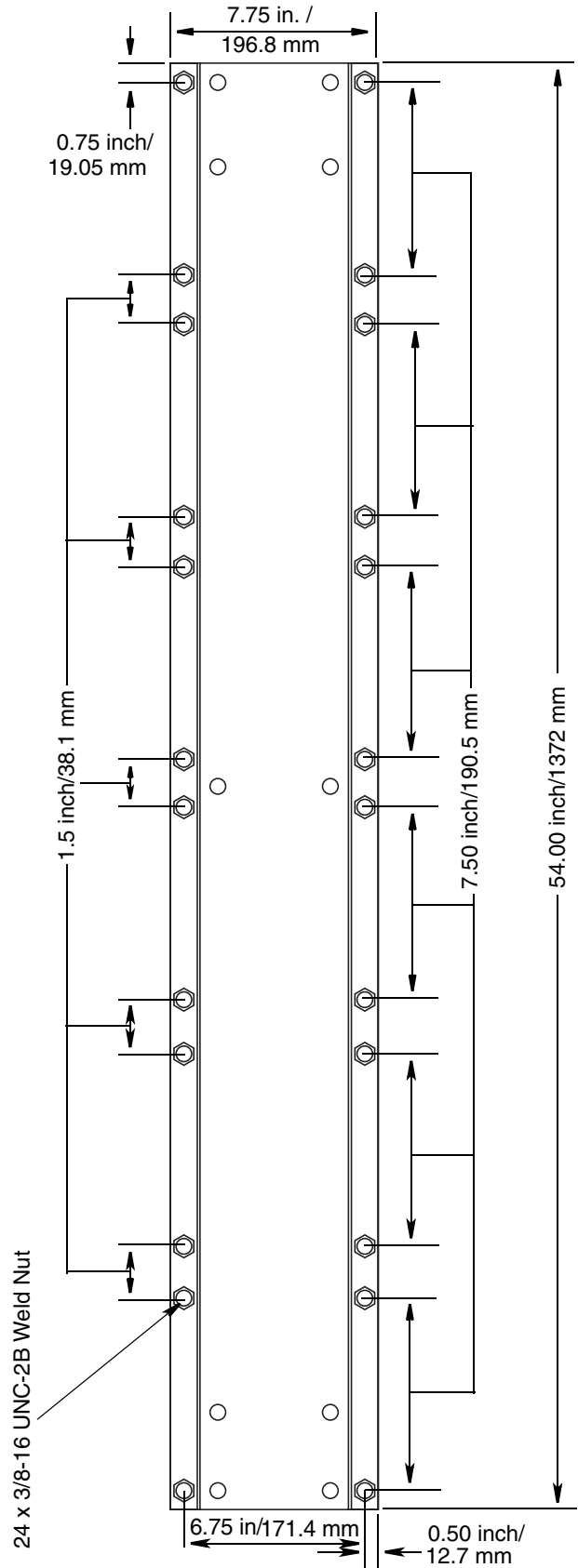

1 Reel Channel Base - Included in Kit 24A219

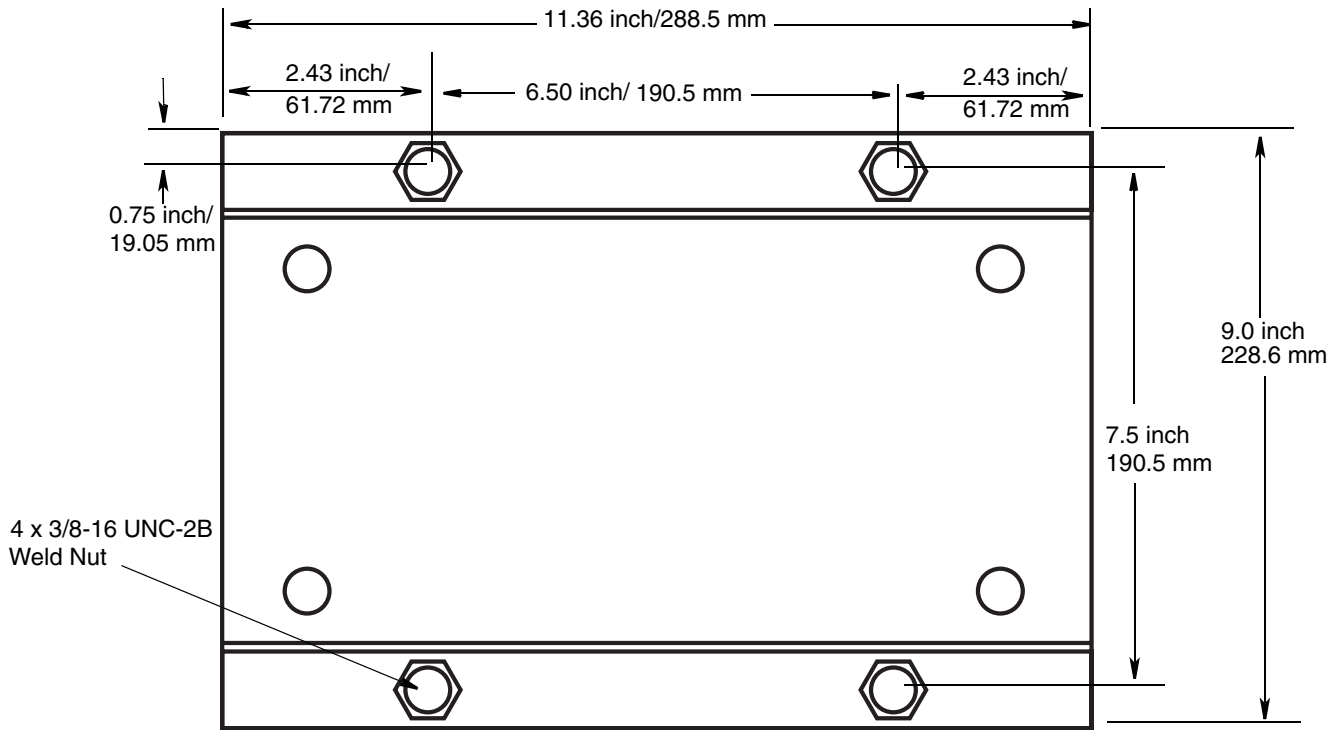

2 Reel Channel Base - Included in Kits 24A220

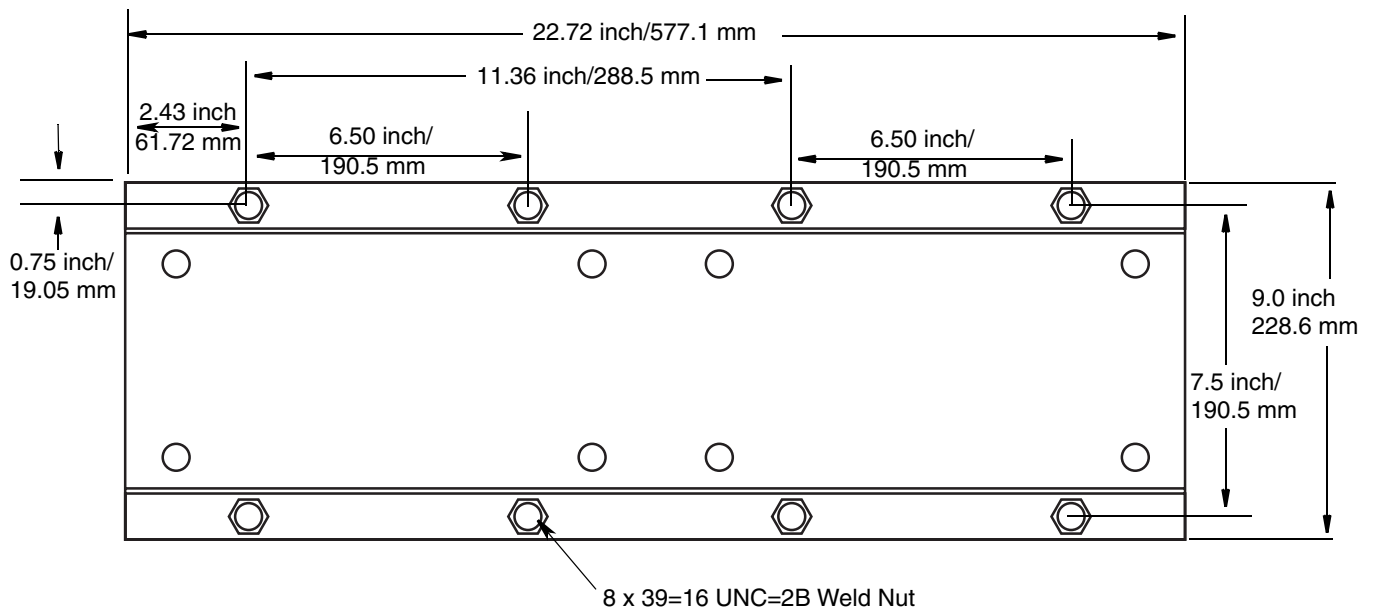

3 Reel Channel Base Weldment

Included in Kits 24A221 - XD (HSXXXX Models)

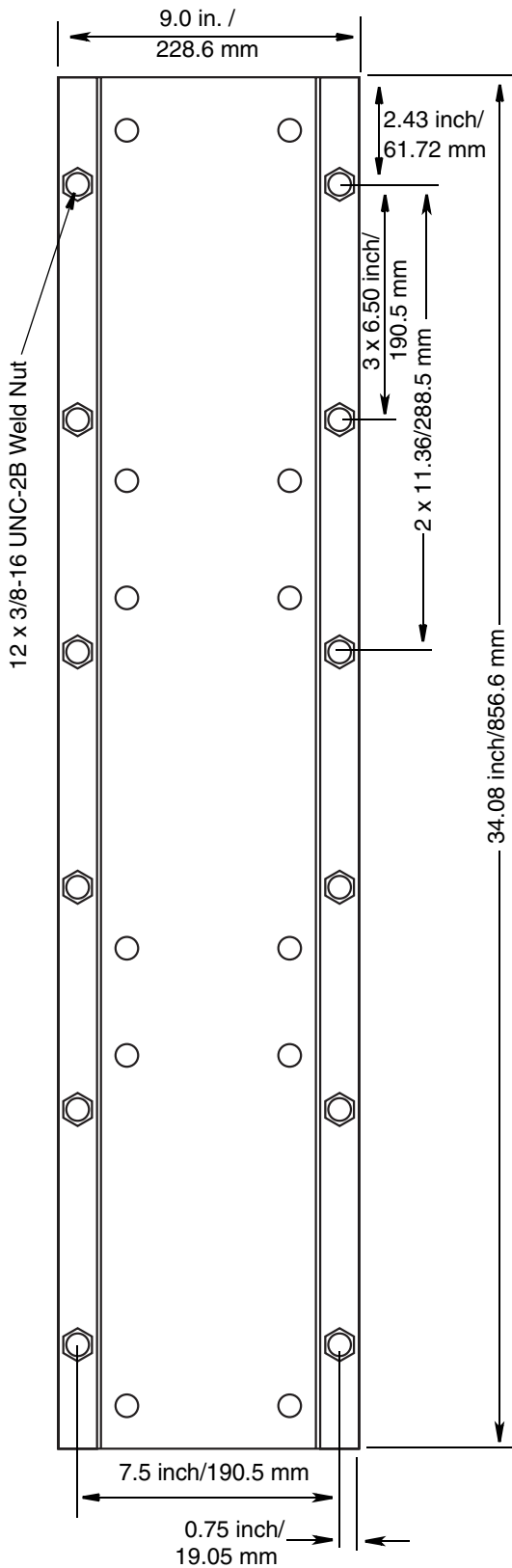

6-Reel Channel Base Weldment

Included in Kits 24A222 - XD (HSXXXX Models)

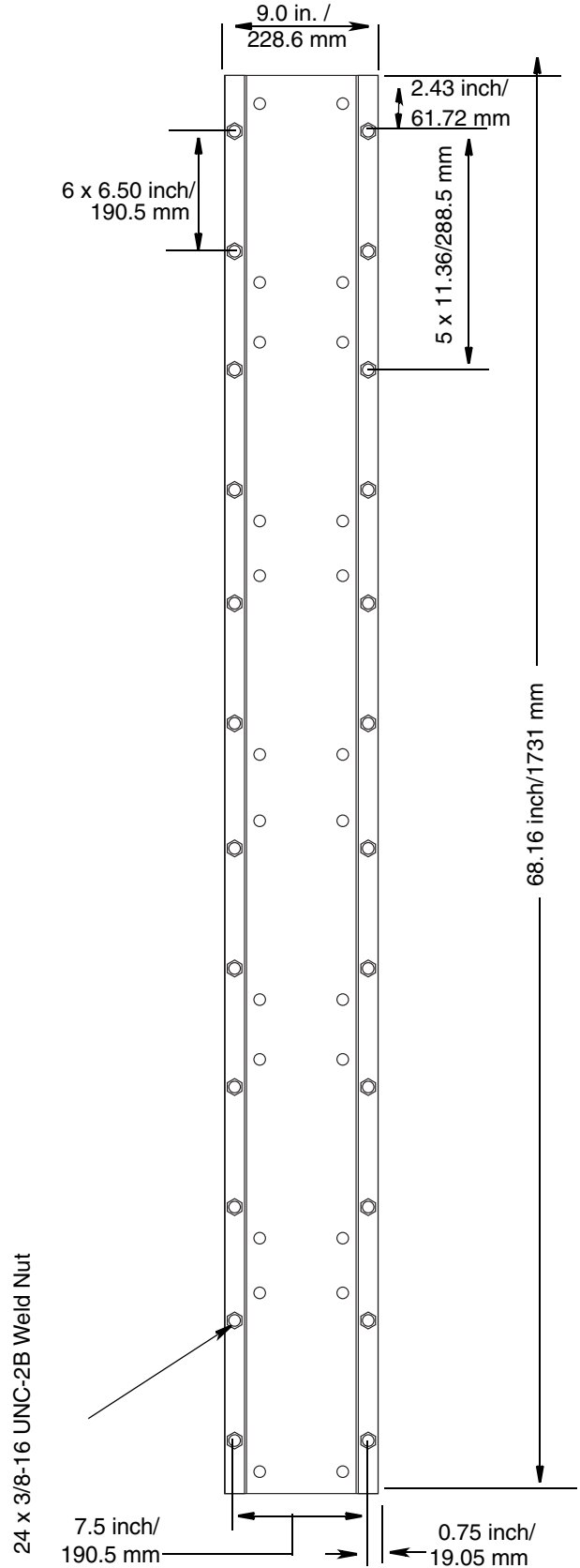

Side Dimension (All Models)



Graco Hose Reel Warranty

Graco warrants all equipment referenced in this document which is manufactured by Graco and bearing its name to be free from defects in material and workmanship on the date of sale to the original purchaser for use. With the exception of any special, extended, or limited warranty published by Graco, Graco will, for a period as defined in the table below from the date of sale, repair or replace equipment covered by this warranty and determined by Graco to be defective. This warranty applies only when the equipment is installed, operated and maintained in accordance with Graco's written recommendations.

Component	Warranty Period
Wear parts, including but not limited to: hose, swivel seals, roller guide	12 months
Reel structural components and spring	36 months
Bare hose reels: all components	12 months

This warranty does not cover, and Graco shall not be liable for general wear and tear, or any malfunction, damage or wear caused by faulty installation, misapplication, abrasion, corrosion, inadequate or improper maintenance, negligence, accident, tampering, or substitution of non-Graco component parts. Nor shall Graco be liable for malfunction, damage or wear caused by the incompatibility of Graco equipment with structures, accessories, equipment or materials not supplied by Graco, or the improper design, manufacture, installation, operation or maintenance of structures, accessories, equipment or materials not supplied by Graco.

This warranty is conditioned upon the prepaid return of the equipment claimed to be defective to an authorized Graco distributor for verification of the claimed defect. If the claimed defect is verified, Graco will repair or replace free of charge any defective parts. The equipment will be returned to the original purchaser transportation prepaid. If inspection of the equipment does not disclose any defect in material or workmanship, repairs will be made at a reasonable charge, which charges may include the costs of parts, labor, and transportation.

THIS WARRANTY IS EXCLUSIVE, AND IS IN LIEU OF ANY OTHER WARRANTIES, EXPRESS OR IMPLIED, INCLUDING BUT NOT LIMITED TO WARRANTY OF MERCHANTABILITY OR WARRANTY OF FITNESS FOR A PARTICULAR PURPOSE.

Graco's sole obligation and buyer's sole remedy for any breach of warranty shall be as set forth above. The buyer agrees that no other remedy (including, but not limited to, incidental or consequential damages for lost profits, lost sales, injury to person or property, or any other incidental or consequential loss) shall be available. Any action for breach of warranty must be brought within 48 months of the date of sale, or 24 months for all other parts.

GRACO MAKES NO WARRANTY, AND DISCLAIMS ALL IMPLIED WARRANTIES OF MERCHANTABILITY AND FITNESS FOR A PARTICULAR PURPOSE, IN CONNECTION WITH ACCESSORIES, EQUIPMENT, MATERIALS OR COMPONENTS SOLD BUT NOT MANUFACTURED BY GRACO. These items sold, but not manufactured by Graco (such as electric motors, switches, hose, etc.), are subject to the warranty, if any, of their manufacturer. Graco will provide purchaser with reasonable assistance in making any claim for breach of these warranties.

In no event will Graco be liable for indirect, incidental, special or consequential damages resulting from Graco supplying equipment hereunder, or the furnishing, performance, or use of any products or other goods sold hereto, whether due to a breach of contract, breach of warranty, the negligence of Graco, or otherwise.

FOR GRACO CANADA CUSTOMERS

The Parties acknowledge that they have required that the present document, as well as all documents, notices and legal proceedings entered into, given or instituted pursuant hereto or relating directly or indirectly hereto, be drawn up in English. Les parties reconnaissent avoir convenu que la rédaction du présente document sera en Anglais, ainsi que tous documents, avis et procédures judiciaires exécutés, donnés ou intentés, à la suite de ou en rapport, directement ou indirectement, avec les procédures concernées.

Graco Information

For the latest information about Graco products, visit www.graco.com.

TO PLACE AN ORDER, contact your Graco distributor or call to identify the nearest distributor.

Phone: 612-623-6928 **or Toll Free:** 1-800-533-9655, **Fax:** 612-378-3590

All written and visual data contained in this document reflects the latest product information available at the time of publication. Graco reserves the right to make changes at any time without notice.

For patent information, see www.graco.com/patents.

Original instructions. This manual contains English. MM 313431

Graco Headquarters: Minneapolis
International Offices: Belgium, China, Japan, Korea

GRACO INC. P.O. BOX 1441 MINNEAPOLIS, MN 55440-1441

Copyright 2009, Graco Inc. is registered to ISO 9001

www.graco.com

Revised February 2014