

POP-IT® Tool

Model PHD0535

Warning

Improper use of POP-IT® Tools may result in injury or death. Do Not Exceed Rated Load of 30,000 lbs. Always Chock Your Work. Follow operating procedures.

**Gearench
P.O. Box 192
4450 South Highway 6
Clifton, Texas 76634
Phone: (254) 675-8651
Fax: (254) 675-6100**

© 2008 by GEARENCH. All rights reserved

Form PHD0535 Revision 07/11/08

Table of Contents

POP-IT® Tool Description	2
Warranty	2
Safe Practices and Procedures.....	4
Responsibility	4
Safety.....	4
Warnings	4
POP-IT® Tool Inspection	5
Operating Procedure – Flange Work.....	5
Operating Procedure – Lifting Work	6
Replacement Parts	8

POP-IT® Tool Description

The POP-IT® Tool takes the place of the hammer, pry-bars and wedge when working with flanges. It can also be used as an equipment lifting tool. The Model PHD0535 reduces the risk of injury, is lightweight and compact and requires minimal maintenance. The tool holds its setting without drifting, has precision adjustment and can spread 15 tons to 5 ½ inches and 10 tons to 8 ½ inches. The Model PHD0535 requires a ½ inch gap for toe insertion. The Model PHD0535 comes with all parts attached and external power is not needed. It's ready to use out of the box.

Warranty

What Is Covered

Gearench tools are expressly warranted to you, the purchaser, to be free of defects in material and workmanship.

How Long Coverage Lasts

This express warranty lasts for the lifetime of the GEARENCH tool. Warranty coverage ends when the tool becomes unusable for reasons other than defects in workmanship or material.

How Can You Get Warranty Service

To obtain the benefit of this warranty, contact a GEARENCH sales representative in Clifton, Texas.
GEARENCH · 4450 South Highway 6 · P.O. Box 192 · Clifton, TX 76634

What Will We Do To Correct Problems

Warranted products will be repaired or replaced, at GEARENCH's option, and returned at no charge to you, the original purchaser; or, if after three attempts at repair or replacement during the warranty period, the product defect in material or workmanship persists, you can elect to receive a full refund of your original purchase price for the product.

What Is Not Covered

Defects, failures or conditions that are due to normal wear and tear, abuse or misuse, are not covered by this limited warranty. In addition, this limited warranty is in lieu of all other warranties, express or implied, verbal or written. To the maximum extent allowed by law GEARENCH disclaims all implied warranties, including implied warranties of merchantability and/or fitness for a particular purpose. GEARENCH also specifically denies any liability for any incidental damages and/or consequential damages, including but not limited to property damage to property other than the product itself, loss of sales profits, down time, costs or any other damages measurable in money, whether or not included in the foregoing enumeration.

Please be advised that some states do not allow the exclusion or limitation of incidental or consequential damages, so this limitation or exclusion may not apply to you. This warranty gives you specific rights, and you may also have other rights, which vary from state to state, province to province, or country to country.

Are Personal Injuries Covered

In the event you, someone working for you, or any other person sustain a personal injury as a result of using the GEARENCH tool, GEARENCH limits its potential liability for such a claim or injury to the fullest extent allowed by law, and disclaims and denies any liability for such personal injury.

Please be advised that some states do not allow the exclusion or limitation of liability for personal injuries, so the above limitation or exclusion may not apply to you, or the individual claiming injury.

No Other Express Warranty Applies

This GEARENCH LIMITED WARRANTY is the sole and exclusive warranty, express or implied for GEARENCH products. No employee, agent, dealer or other person is authorized to alter, modify, expand or reduce the terms of this warranty or to make any other warranty on behalf of GEARENCH.

Law Applicable

All matters related to the sale and/or use of the GEARENCH tool that is the subject of this limited warranty, along with the construction and enforcement of the terms of this limited warranty itself, shall be subject to the substantive and procedural laws of the state of Texas, not the conflicts of laws provisions of Texas, but rather the laws of Texas themselves.

Forum Selection Clause

Any dispute arising out of the sale and/or use of the GEARENCH tool that is the subject of this limited warranty shall be presented in the form of a claim or lawsuit to the offices of GEARENCH in Clifton, Bosque County, Texas. No claim or suit may be brought against GEARENCH, arising out of the sale and/or use of the tool, or arising out of the terms of this warranty, except in such forum. Purchase and/or use of the GEARENCH tool makes you subject to the benefits and limitations of this limited warranty. Accordingly, any writ, judgment or other enforcement, obtained from a jurisdiction, county, parish, state or federal court or other country, other than that from the forum identified above, shall be void and unenforceable against GEARENCH.

Arbitration Clause

In the event of dispute or claim arises out of the sale and/or use of the GEARENCH tool that is the subject of this limited warranty, or arises out of the interpretation or enforcement of the terms and conditions of this limited warranty, such dispute shall be submitted to binding arbitration pursuant to the rules of the American Arbitration Association. If required to accomplish the purpose of this Arbitration clause, the purchaser hereby expressly waives any right to demand trial by jury.

Complete Agreement

This express limited warranty contains the entire agreement regarding express or implied warranties related to the GEARENCH tool that is the subject of it. No writing or language contained in the purchase order or any other document of the purchaser, or invoice of GEARENCH or any intermediate seller, shall be construed as modifying, in any way, the rights and liabilities contained in this limited warranty. Gearench expressly disclaims any obligations expressed in any customer purchase order or document that are contrary to the terms and limitations of this warranty.

Severability

If any term or limitation contained in this limited warranty is deemed unenforceable by law, then the term shall be severed from the remaining portions of the limited warranty which shall remain enforceable.

All communications to GEARENCH regarding the use of the tool and any aspect of the sale of the tool of this limited warranty should be addressed to GEARENCH.

GEARENCH · 4450 South Highway 6 · P.O. Box 192 · Clifton, TX 76634

Safe Practices and Procedures

Responsibility

"It is the responsibility of the employer to train the employee in the proper selection and use of tools, and to ensure that they are selected and used in that manner. A part of the job instruction program should therefore be detailed training in the proper use of POP-IT® Tools.

"Employers are responsible for the safe condition of tools and equipment used by employees, including tools and equipment which may be furnished by employees." - (Source: OSHA 1910.242A)

Safety

While we pride ourselves on the quality and dependability we build into GEARENCH tools and products, we caution users that it is only prudent to know and follow the simple rules of safety when using our products, or anyone else's.

Always follow safe practices and procedures in accordance with the recommendations of OSHA, The National Safety Council (NSC), The Hand Tools Institute (HTI), Etc. All applicable Governmental rules, regulations or restrictions, now in effect or which may be promulgated, take precedence over the suggestions in this publication. The information in this publication is designed to supplement standard safe practices and procedures, not in lieu of, or replacement thereof.

Warnings

- Always chock your work
- Never use cheaters
- Never place fingers or other body parts between flanges or under equipment
- Do not jerk on the ratchet handle. Always use a steady pulling force
- Insert toes as far as possible into work piece
- If using two tools, always operate the tools in sync with one another
- Always tether the tool to keep it from falling

POP-IT® Tool Inspection

Prior to each use:

- Clean serrations on toes with a wire brush
- Inspect toes for possible cracks or chipped surfaces – replace immediately if either is found.
- Verify that all bolts and screws on the tool are tight.

Every six months:

- Remove screw assembly. Remove any debris from the screw and apply a thin coat of anti-seize compound.

Operating Procedure – Flange Work

Note: In some cases it will be necessary to use two tools to keep from pinching the blind or gasket on the opposite side of the flange, or the flange may be so large and rigid that it requires two tools. **When using two tools, it is very important to operate the tools in sync with one another while opening and closing.**

Step 1

Before every use, clean the serrations on the toes with a wire brush. Insert the toes of the tool into the flange as far as possible. The first step or entry point of the toes is a ½ inch thick. The next two steps are 1 inch and 1 ½ inch. The bulk of spreading should be done at the 1 inch and 1 ½ inch steps. Do not try to reach maximum force of 30,000 lbs on the first step. **Always chock your work when moving from one step of the toe to another.**

Step 2

Once the toes are in as far as possible, flip the direction switch on the ratchet to the left. Begin turning the ratchet handle clockwise in a slow manner until the flange opens at least one inch. Insert a 1 inch chock and then remove the tool. Re-insert the tool on the 1 inch step and begin spreading until you reach the desired opening. **DO NOT USE A CHEATER BAR. The POP-IT® Tool is designed to be operated with the ratchet supplied.** Do not jerk on the ratchet handle. A steady even pull ensures smooth operation. Approximately 300 lbs of force on the end of the ratchet handle will produce 30,000 lbs of force. If this is not enough, you may need two tools to spread the flange.

- The outside toes of the tool can be removed and then reset, allowing you to spread or lift a total of 8 inches. With the toes extended, the spreading or lifting capacity of the tool is reduced to 20,000 lbs.

Step 3

ALWAYS CHOCK YOUR WORK. Never leave the tool in the flanges while performing maintenance. After the flange is spread to the desired amount, set a chock between the flanges. Flip the direction switch on the ratchet handle to the right. With one hand on the tool handle, turn the ratchet handle counter clockwise to close the flanges onto the chock and remove the tool.

Step 4

Perform necessary flange maintenance.

Step 5

Insert the POP-IT® Tool beside the chock. Flip the direction switch on the ratchet back to the left. While holding the tool handle, turn the ratchet handle clockwise until the chock comes free. After removing the chock, flip the direction switch to the right. Turn the ratchet handle counter clockwise until the flange is back to parallel.

Step 6

Remove the POP-IT® Tool from the flange. If necessary, remove the tool by tapping lightly on the side of the tool with a hammer.

Operating Procedure – Lifting Work

Step 1

Before every use, clean the serrations on the toes with a wire brush. Make sure that all toes are fully engaged under the equipment to be lifted. The first step or entry point of the toes is a ½ inch thick. The next two steps are 1 inch and 1 ½ inch. The bulk of lifting should be done at the 1 inch and 1 ½ inch steps. Do not try to reach maximum force of 30,000 lbs on the first step.

Step 2

Once the toes are in as far as possible, flip the direction switch on the ratchet to the left. With one hand located on the handle of the tool, take your other hand and begin turning the ratchet handle clockwise in a slow manner as the equipment begins to lift. **DO NOT USE A CHEATER BAR. The POP-IT® Tool is designed to be operated with the ratchet supplied.** Do not jerk on the ratchet handle. A steady even pull insures smooth operation. Approximately 300 lbs of force on the end of the ratchet handle will produce 30,000 lbs of force.

- The outside toes of the tool can be removed and then reset, allowing you to spread or lift a total of 8 inches. With the toes extended, the spreading or lifting capacity of the tool is reduced to 20,000 lbs.

Step 3

ALWAYS CHOCK YOUR WORK. Never allow the tool to support the load while working on the equipment. After the equipment is lifted to the desired amount, set a chock under the equipment. **NEVER PLACE YOUR FINGERS OR ANY OTHER BODY PART UNDER THE EQUIPMENT WHILE THE POP-IT® TOOL IS SUPPORTING THE LOAD.** Flip the direction switch on the ratchet handle to the right. With one hand on the tool handle, turn the ratchet handle to the right. With one hand on the tool handle, turn the ratchet handle counter clockwise to lower the equipment onto the chock. Remove the tool.

Step 4

Perform necessary maintenance/task.

Step 5

Insert the POP-IT® Tool beside the chock. Flip the direction switch on the ratchet back to the left. While holding the tool handle, turn the ratchet handle clockwise until the chock comes free. After removing the chock, flip the direction switch to the right. Turn the ratchet handle counter clockwise until the equipment is lowered to its desired position. Remove the tool.

Replacement Parts

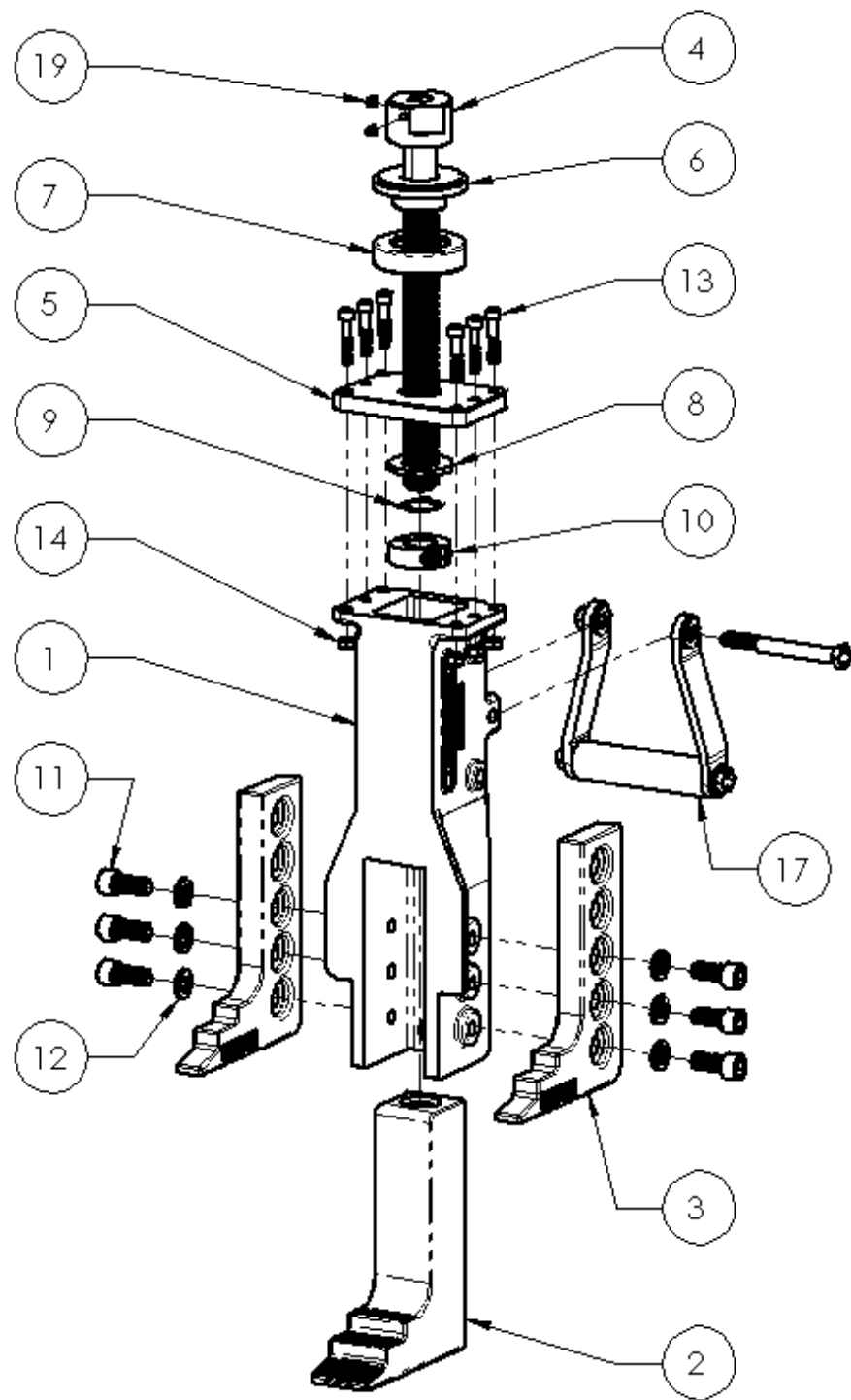

Item	Qty.	Part No.	Description
1	1	PE0525	Body
2	1	PD0527	Riser
3	2	PD0526	Outside toe
4	1	PC0605	Drive screw
5	1	PC0530	Top plate
6	1	PB0605	Bearing flange
7	1	HXB02	Thrust bearing
8	1	HXW025	Flat washer
9	1	HS34	Wave disc spring
10	1	HXSC02	Shaft collar
11	6	HXS061	Socket head cap screw
12	6	HXW027	Spring lock washer
13	6	HXS060	Socket head cap screw
14	6	HXN066	Stover locknut
15	1	LBL-092	Model patent label (not shown)
16	1	LBL-095	Instruction label (not shown)
17	1	PC0532	Handle assembly
18	1	PD0533	Ratchet (not shown)
19	2	HXSS006	Set screw