

300 & 700 Series Bung Adapter / Suction Pipe Assembly and Installation

FR300 and 700 Series Pumps feature a 2" Bung Adapter with integral connection for an anti-siphon device. When installing the suction pipe into the bung adapter, the suction pipe must be inserted into the bung adapter correctly for proper operation. Follow the directions below to insure a correct installation and proper operation.



WARNING! Threaded pipe joints and connections should be sealed with the appropriate sealant or sealant tape to minimize the possibility of leaks. Leaking fuel may cause the potential for fire and explosion.

The FR300 and 700 series pump mounts to the bung of a tank by way of the bung adapter. The suction pipe threads into the tank adapter, and must be cut to a length that positions it at least 3" from the bottom of the tank (Figure 1). The tank must be equipped with a vent cap.

- 1) Measure and cut suction pipe to fit as described above.
- 2) Examine the bung adapter to determine top and bottom for proper insertion of the suction pipe. The bung adapter is labeled to help: the end marked "PUMP SIDE" is the top of the bung adapter (Figure 2). Note that the internal threads for the suction pipe are at the **TOP** of the opening.

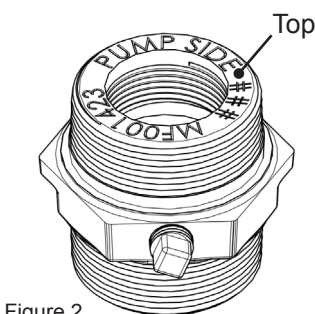

Figure 2

- 3) Wrap the threads of the suction pipe with the appropriate sealant for the fluid being pumped. Insert the suction pipe (with the threaded side up) into the bottom of the bung adapter until the threads engage (Figure 3A, 3B, and 3C). Tighten to create an air / fluid tight seal.

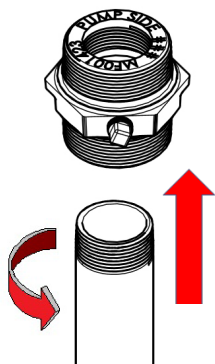

Figure 3A

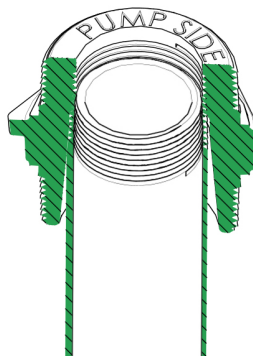

Figure 3B

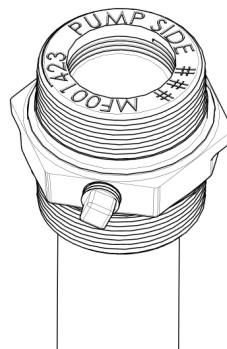
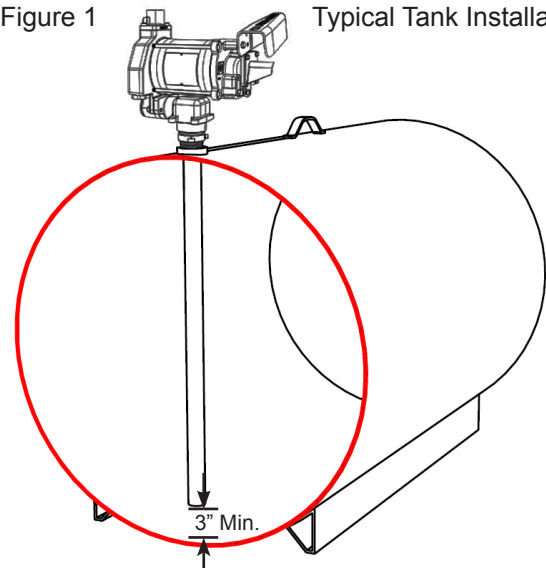

Figure 3C

Figure 1 Typical Tank Installation



- 4) Tighten the suction tube into the bung adapter to create an air / fluid tight seal.

- 5) Apply an anti-sieze thread compound to the external threads on the bottom of the bung adapter. Install the assembled bung adapter and suction pipe into the bung opening on the tank. Tighten to a fluid / air tight seal (Figure 4).

- 6) Install pump onto bung adapter using appropriate fluid sealant, and tighten to a fluid / air tight seal.

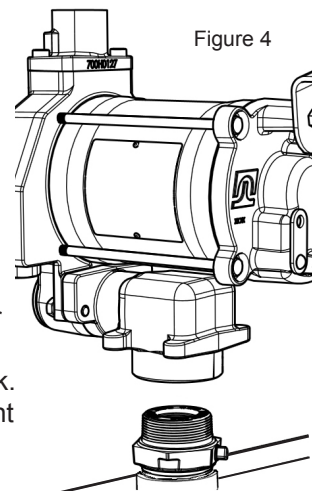

Figure 4